

# STEERING GEAR - POWER

1988 Jeep Cherokee

1987-88 STEERING

Jeep Power Steering Gears - Saginaw Rotary Valve

Cherokee, Comanche, Grand Wagoneer, Pickup, Wagoneer, Wrangler

## DESCRIPTION

Steering gear is a recirculating ball-type, available in either a constant or a variable ratio design. Steel balls form a "rolling thread" between steering gear worm shaft and rack/piston nut. Worm shaft thrust is absorbed by a thrust bearing and two races at lower end, and by a bearing in adjuster plug at upper end.

This design puts spring pressure on worm shaft to ensure proper thrust bearing preload. Adjuster plug provides initial preload adjustment and service adjustment (when repairing gear). As worm shaft is turned right, rack/piston is moved upward in gear.

As worm shaft is turned left, rack/piston is moved downward in gear. The rack/piston teeth mesh with sector, which is forged as part of sector shaft. Rotating worm shaft moves sector shaft, which turns wheels through mechanical linkage. See Fig. 1.

## TROUBLE SHOOTING

Refer to TROUBLE SHOOTING - BASIC PROCEDURES article in the GENERAL TROUBLE SHOOTING section.

## LUBRICATION

See POWER STEERING GENERAL SERVICING article.

## TESTING

See POWER STEERING GENERAL SERVICING article.

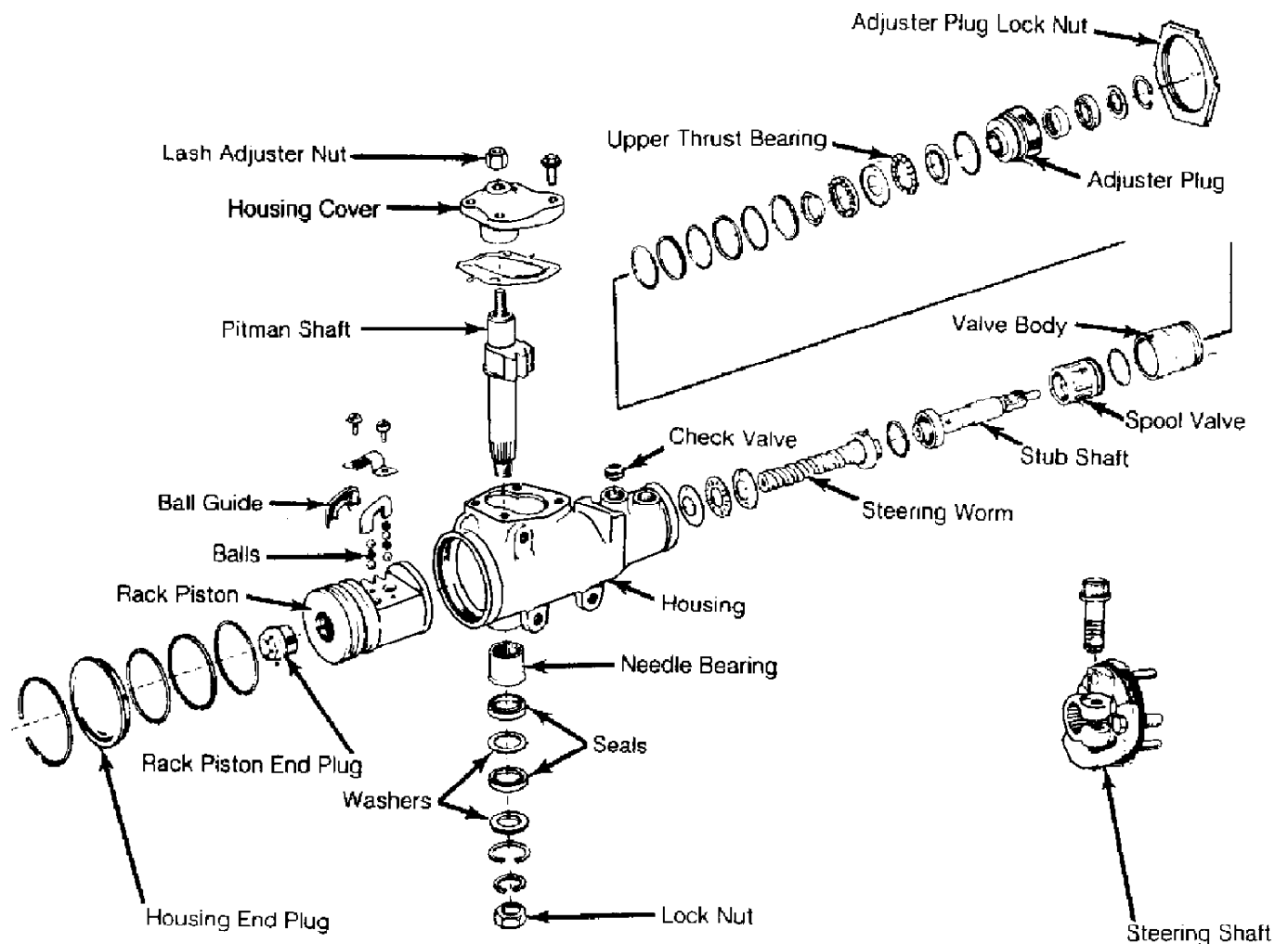

30538

Fig. 1: Exploded View of Saginaw Rotary Valve Power Steering Gear

## ADJUSTMENTS

### THRUST BEARING PRELOAD ADJUSTMENT

1) Remove steering gear from vehicle. Remove adjuster plug lock nut. Turn adjuster plug clockwise with a spanner wrench until plug is seated in housing. This will require 20-30 ft. lbs. (27-41 N.m) of torque.

2) Place an index mark on housing opposite one spanner wrench hole in adjuster plug. Measure 1/2" (13 mm) counterclockwise from mark and again mark housing. Rotate plug counterclockwise until hole in adjuster lines up with second mark.

3) Tighten lock nut. Ensure adjuster remains in position. Attach an INCH lb. torque wrench to end of input shaft. Turn input shaft to right stop, then back 1/4 turn.

4) Using torque wrench measure rotational torque required to turn shaft. Reading should be taken with beam of torque wrench near vertical while turning it counterclockwise at an even rate. Torque reading should be 4-10 INCH lbs. (.4-1.1 N.m). See. Fig. 2.

NOTE: If reading does not fall within this range, adjuster plug may have turned while lock nut was being tightened. Steering gear may be incorrectly assembled or worm shaft thrust bearings and races may be defective. Repair as required and readjust preload.

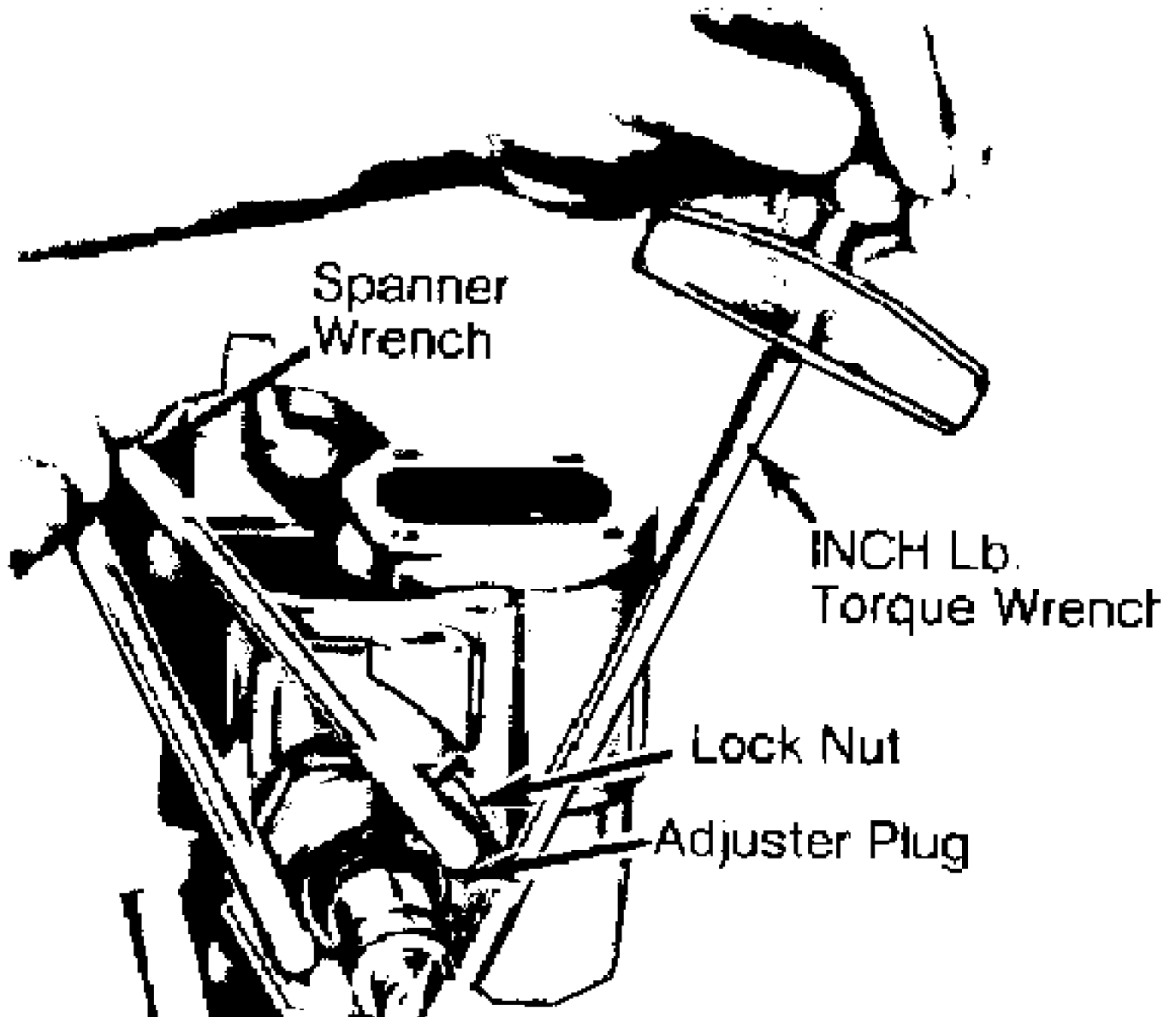

**30539**

Fig. 2: Measuring Thrust Bearing Preload

#### OVER-CENTER PRELOAD TORQUE ADJUSTMENT

1) Loosen adjuster screw lock nut. Back off adjuster screw until stopped, then turn in 1 full turn. Rotate input shaft from stop to stop counting number of turns. Turn shaft half way back to center position.

2) Attach an INCH lb. torque wrench to input shaft. Turn

shaft from side to side through specified arc on each side of center. See OVER-CENTER PRELOAD chart. Note torque reading going over center. Adjust thrust bearing preload before over-center preload. See Fig. 3.

OVER-CENTER PRELOAD SPECIFICATIONS - INCH LBS. (N.m)

Application	Arc	Over-Center	(1) Total
New Gears .....	45° .....	4-8 (.4-.9) .....	14 (1.5)
Used Gears (2) .....	45° .....	4-5 (.5-.6) .....	14 (1.5)

(1) - Total preload is sum of thrust bearing and over-center preload.

(2) - In service for more than 400 miles (640 km.).

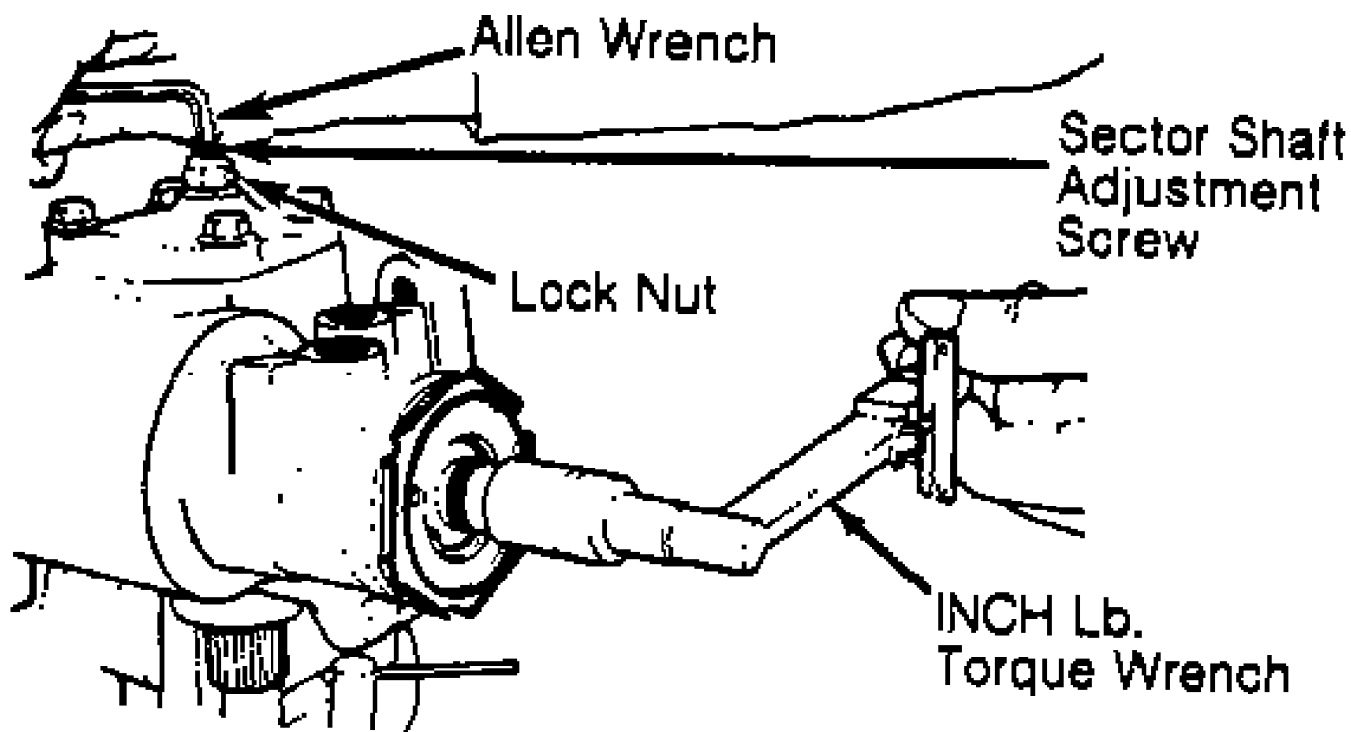

**30540**

Fig. 3: Adjusting Over-Center Preload

**REMOVAL & INSTALLATION**

**POWER STEERING PUMP**

Removal & Installation

1) Loosen and remove pump drive belt. Disconnect pressure and return hoses from pump. Cap ends to prevent loss of fluid or contamination.

2) Remove bracket-to-engine bolts. Remove pump and mounting bracket as an assembly. To install, reverse removal procedure. Fill and bleed system.

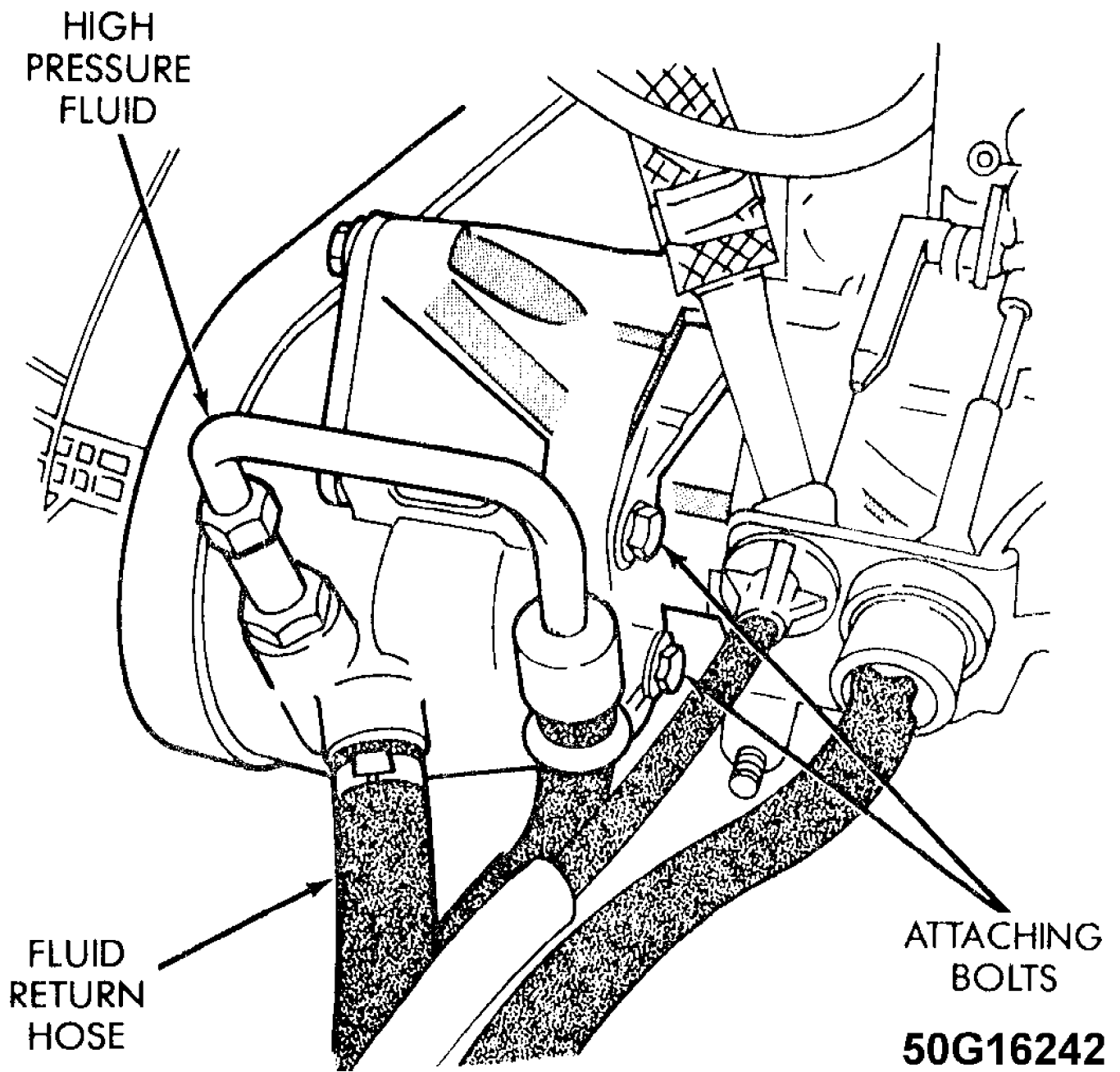

Fig. 4: Power Steering Pump (Cherokee & Comanche)

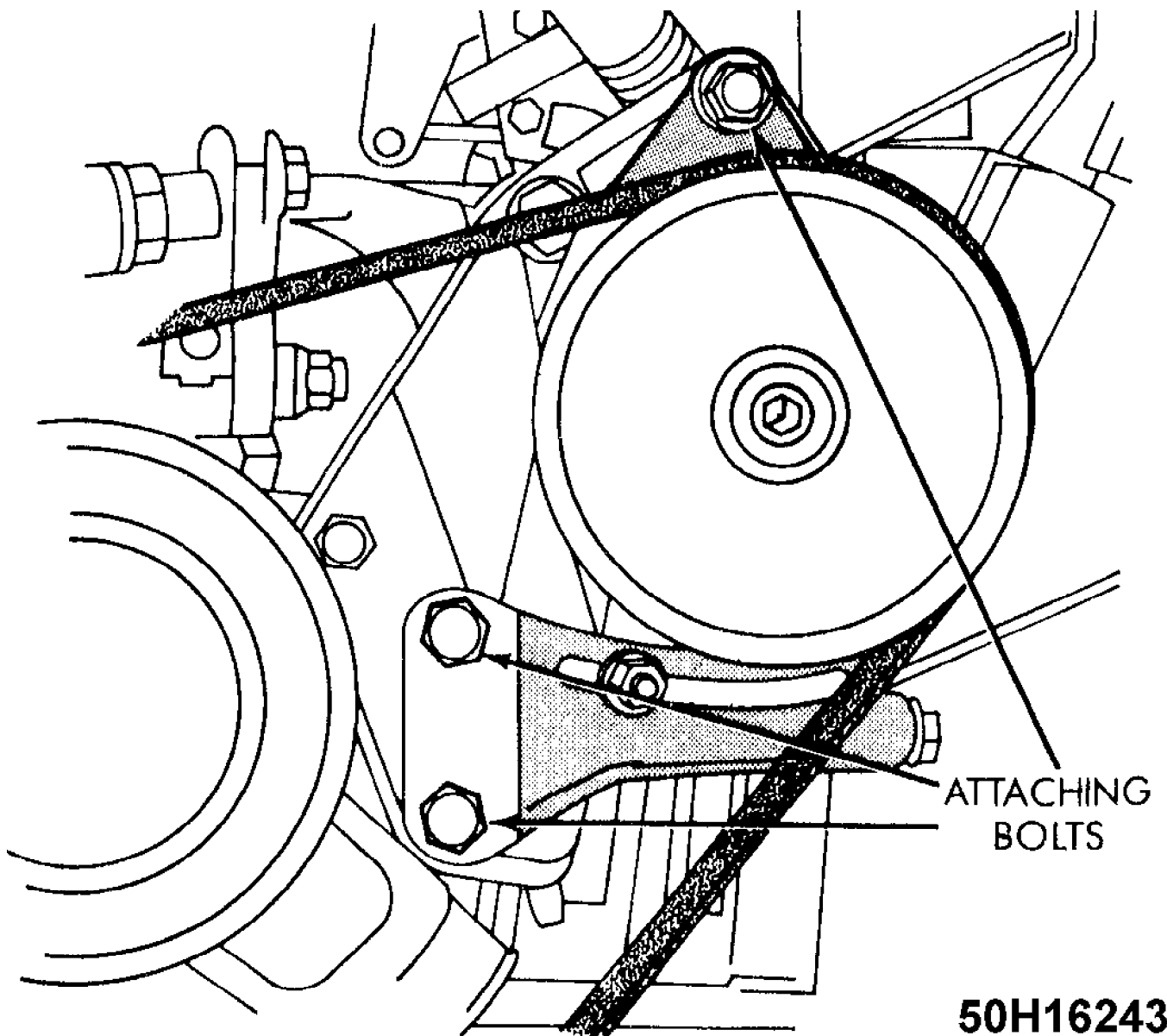

Fig. 5: Front Bracket Boltsp (Cherokee & Commanche)

**50H16243**

## STEERING GEAR

### Removal

1) Remove collapsible steering column. Raise and support vehicle. Place drain pan under steering gear assembly. Center steering gear. Disconnect hydraulic hoses from gear and cap ends. Disconnect steering linkage from pitman arm. Remove pitman arm from gear.

2) Remove flexible coupling clamp bolt and bolts retaining steering gear to frame. Disconnect gear from flexible coupling and remove gear from vehicle. On Jeep CJ7 and Scrambler models, remove steering gear and mounting bracket as an assembly.

### Installation

To install, reverse removal procedure. Fill pump reservoir. Bleed air from system. See POWER STEERING GENERAL SERVICING article.

## OVERHAUL

### SUBMERGED VANE POWER STEERING PUMP

#### Disassembly

1) Drain pump reservoir. Clean exterior of unit. Measure distance shaft protrudes from pulley, and record for assembly reference. Using pulley remover, remove pulley from shaft. Clamp pump in vise; DO NOT overtighten vise. Remove pressure line union, reservoir mounting stud and reservoir. See Fig. 6. Remove and discard pressure line union "O" rings.

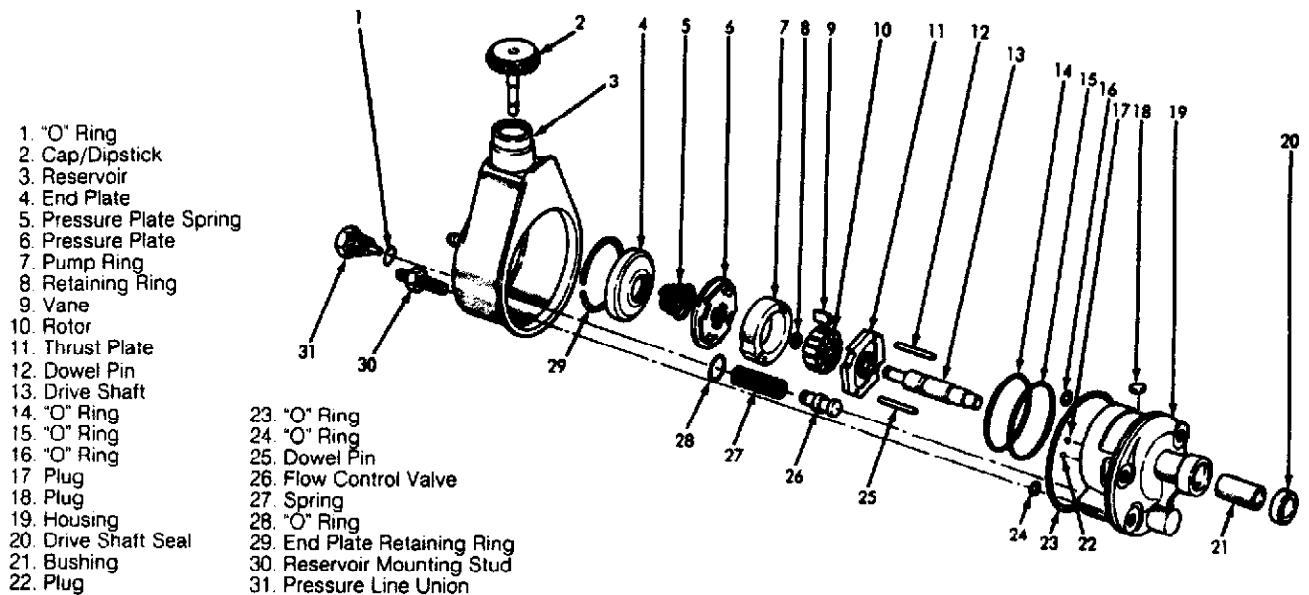

Fig. 6: Exploded View of Pump Assembly (Grand Wagoneer & Wrangler)  
Courtesy of Chrysler Motors

2) Using punch and screwdriver, remove end plate retaining ring. Remove end plate and pressure plate spring. Remove "O" ring, flow control valve and spring. Note direction of pump ring installation for reassembly reference.

3) Using soft-faced hammer, tap end of drive shaft to loosen pressure plate. Remove pressure plate, pump ring, vanes, retaining ring, rotor and thrust plate assembly from body. Remove drive shaft. Using a screwdriver, pry drive shaft oil seal from housing. Remove dowel pins and seals.

#### Cleaning & Inspection

1) Clean all pump components in solvent, and blow dry. Inspect flow control valve assembly for wear, scoring, burrs and other damage. Inspect seal bore for burrs, nicks and score marks.

2) Inspect machined surfaces of body for scratches and burrs. Check "O" ring mating surfaces. Inspect drive shaft for excessive wear.

3) Inspect pump ring for roughness. Check thrust plate and pressure plate for scoring and wear. Ensure vanes slide freely but fit snugly into slots. If vanes are loose in slots, replace rotor and/or vanes.

#### Reassembly

1) Before installation, coat all "O" rings, rotor, pressure

plate and end plate with petroleum jelly. Install new drive shaft seal in housing. Install "O" ring in third groove of housing. Install dowel pins in thrust plate. Install drive shaft through thrust plate and rotor. Install NEW retaining ring. Ensure rotor slides freely on drive shaft splines.

2) Install drive shaft in pump housing. Ensure thrust plate engages with dowel pins. Install pump ring on dowel pins with rotation arrow facing upward. Install vanes with rounded edges toward pump ring.

3) Lubricate outer chamfered edge of pressure plate with petroleum jelly. Install pressure plate with spring groove facing upward. To seat pressure plate, place large socket on pressure plate and press downward approximately 1/16".

4) Install end plate "O" ring in second groove of housing. Install pressure plate spring and end plate in housing. Press end plate downward, and install retaining ring. Install "O" ring, flow control valve and spring.

5) Install mounting stud and pressure line union "O" rings in rear of pump housing. Lubricate inner edge of reservoir with petroleum jelly, and install. Install mounting stud. Tighten stud to specification. Install pressure line union, and tighten to specification. See appropriate table under TORQUE SPECIFICATIONS.

6) Using Pump Pulley Installer (J-25033-B), install pulley on pump shaft. Ensure shaft protrudes distance measured in disassembly procedure.

7) When replacing plastic pulley with metal pulley, install pulley flush with end of shaft. Install pump on engine, and compare alignment with adjacent pulleys. If necessary, correct alignment by using pump pulley installer to adjust shaft protrusion.

## NON-SUBMERGED VANE POWER STEERING PUMP

### Disassembly

1) Remove return tube. Clean exterior of unit. Measure distance shaft protrudes through pulley, and record for reassembly reference. Using pulley remover, remove pulley from shaft. Remove fitting, "O" ring, flow control valve and spring. See Fig. 7.

2) Remove snap ring, drive shaft and bearing. Note direction of snap ring installation for reassembly reference. Support drive shaft bearing on inner race, and press drive shaft from bearing. Using screwdriver, remove drive shaft seal from housing.

3) Insert punch into access hole to disengage and remove retaining ring. Using a brass drift, tap on thrust plate, and remove. Remove "O" ring, pump ring, rotor and vanes. Remove dowel pins, pressure plate, "O" ring and pressure plate spring. Remove "O" ring, dowel pin and sleeve.

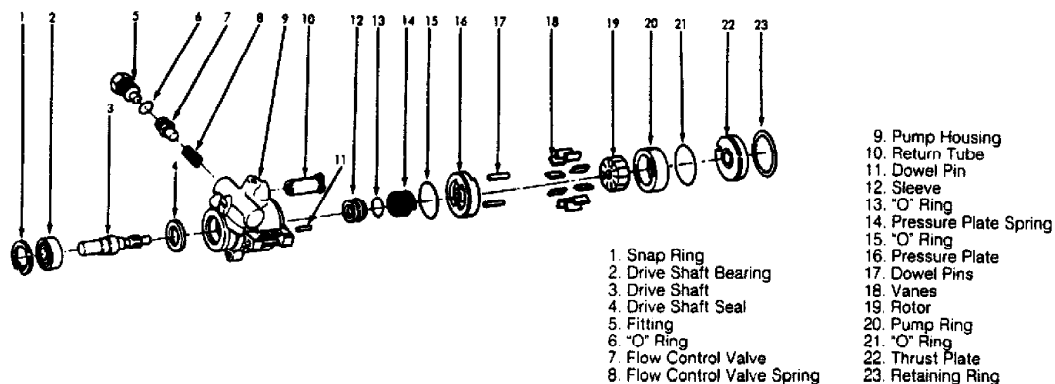

Fig. 7: Exploded View of Cherokee & Comanche Pump Assembly  
Courtesy of Chrysler Motors



### Cleaning & Inspection

1) Clean all pump components in solvent, and blow dry. Inspect flow control valve assembly for wear, scoring, burrs and other damage. Inspect seal bore for burrs, nicks and score marks.

2) Inspect machined surfaces of body for scratches and burrs. Check "O" ring mating surfaces. Inspect drive shaft and sleeve for wear.

3) Inspect pump ring for roughness. Check thrust plate and pressure plate for scoring and wear. Ensure vanes slide freely but fit snugly into slots. If vanes are loose in slots, replace rotor and/or vanes.

### Reassembly

1) Lubricate all "O" rings, seals, pump ring, rotor and vanes with petroleum jelly. Install sleeve. Ensure sleeve is fully seated.

2) Install "O" ring in sleeve seat. Install small dowel pin in pump housing. Install pressure plate spring and "O" ring. Install pressure plate with dowel pin hole aligned with dowel pin holes. Install dowel pins.

3) Install pump ring with identification marks located adjacent to one dowel pin. Install rotor with counterbore toward drive shaft end of housing.

4) Install vanes with rounded edges toward pump ring. Install thrust plate "O" ring. Install thrust plate with indentations aligned with bolt holes of housing. Install retaining ring.

CAUTION: Pump ring must be installed with identification marks located adjacent to dowel pins. Thrust plate must be installed so indentations in thrust plate align with bolt holes of housing and thrust plate engages with pump ring dowel pins.

5) Using a socket, install drive shaft seal in housing until seal bottoms. Support drive shaft bearing on inner race, and press drive shaft into bearing. Install drive shaft and bearing in pump housing.

6) Rotate drive shaft during installation to align with rotor serrations. Ensure bearing is fully seated in pump housing. Snap ring should be installed with large lug area (near snap ring pliers hole) positioned right of small lug (near snap ring pliers hole), ensuring beveled area of snap ring is properly positioned.

7) Install spring, flow control valve and "O" rings. Install return tube with new "O" ring. Install pulley.

## STEERING GEAR

### Disassembly

1) Cap all openings in gear. Clean gear exterior thoroughly. Mount gear in vise so that pitman shaft points downward. Rotate housing end plug retainer ring until one end of plug is over the hole in the housing.

2) Force end of ring from groove in housing and remove. Rotate input shaft counterclockwise to force housing end plug out of housing. Rotate input shaft clockwise 1/2 turn to draw rack/piston inward. Remove piston end plug.

CAUTION: DO NOT rotate shaft more than is necessary to remove plug as ball bearings will fall out of worm and rack piston assembly.

3) Remove lock nut from sector shaft adjuster. Remove sector shaft cover. Remove and discard "O" ring from cover. Turn input shaft until sector shaft teeth are centered in housing.

4) Tap end of sector shaft with a soft-faced hammer to free shaft from housing, then remove sector shaft. Remove adjuster plug lock nut. Remove adjuster plug with a spanner wrench.

5) Insert a rack/piston arbor into end of rack/piston until arbor just contacts worm shaft. Turn stub shaft counterclockwise to force rack/piston onto arbor. Remove rack/piston and arbor as an assembly.

6) Take care to keep arbor fully inserted so ball bearings will not fall out. Remove input shaft and control valve assembly from housing. Remove worm, wormshaft lower thrust bearing, and races from housing.

#### Reassembly

1) Lubricate all parts with clean power steering fluid before reassembly. Install the lower thrust bearing and races onto the worm. Cupped side of thrust washers must face toward stub shaft. See Fig. 8.

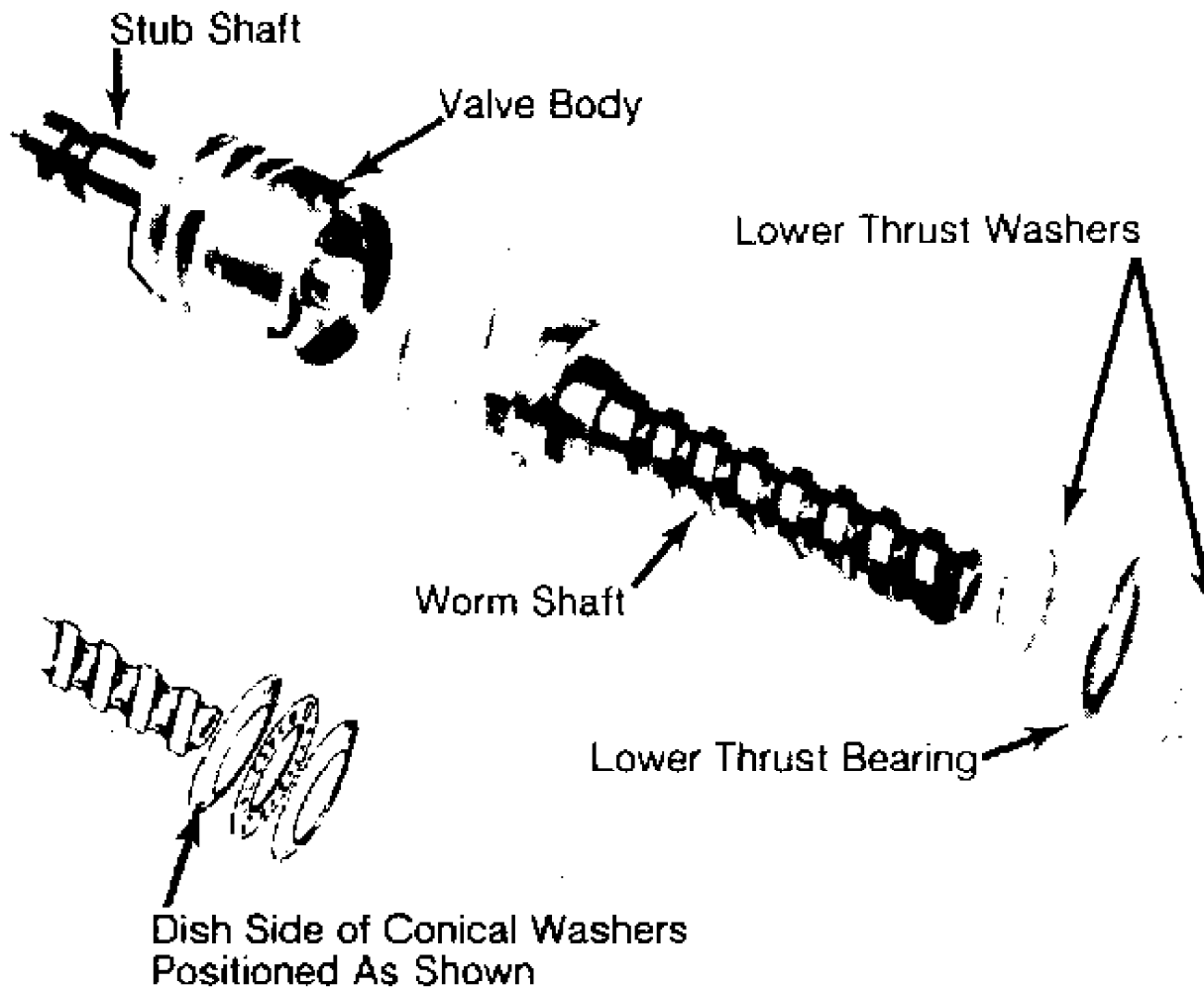

30541

Fig. 8: Reassembly of Valve Body & Worm Shaft Assembly

NOTE: If conical thrust races are used, ensure tapered surfaces are parallel to each other and that cupped sides face toward stub shaft.

2) Install stub shaft cap "O" ring in valve body. Align valve body drive pin on worm with narrow pin slot in valve body. Worm drive lugs must engage in stub shaft cap.

3) Install valve body and worm assembly into housing. Perform installation by pressing directly on valve body only. This will prevent stub shaft "O" ring from disengaging from valve body.

4) Valve body is correctly seated when fluid return port in housing is fully visible. Ensure worm locating pin is fully engaged in valve body. Place seal protector over input shaft, install a new adjuster plug "O" ring, then install adjuster plug.

5) Remove seal protector from housing and loosely install adjuster plug lock nut. Insert arbor and rack/piston into housing. Align worm and rack/piston and turn stub shaft clockwise to engage worm. Maintain pressure on arbor until worm is fully engaged.

6) Turn input shaft clockwise until middle rack groove in rack/piston is aligned with center of sector shaft roller bearing. Remove arbor. Install a new sector shaft cover gasket.

7) Thread sector shaft cover onto adjuster screw until bottomed. Back off 1 1/2 turns. Install sector shaft so that center gear tooth meshes with center groove in rack/piston. Install cover attaching bolts.

8) Install adjuster lock nut halfway onto sector shaft. Install piston and plug in rack/piston. Install housing end plug "O" ring, end plug and retainer ring. Adjust worm bearing preload and over-center preload at this time.

## ADJUSTER PLUG

### Disassembly

1) Remove thrust bearing retainer ring with a screwdriver, taking care not to score needle bearing bore. Discard retainer ring. Remove thrust bearing spacer, thrust bearing and bearing races.

2) Remove and discard adjuster plug "O" ring, then remove input shaft seal retainer. Remove and discard dust seal. Pry input shaft seal from adjuster plug.

3) Inspect needle bearing in adjuster plug. If necessary, remove bearing by pressing out from spacer end. See Fig. 9.

### Inspection

Inspect thrust bearing for cracks and rollers for pitting, scoring, or cracking. Check thrust races and spacer for damage or damage. Replace parts as necessary.

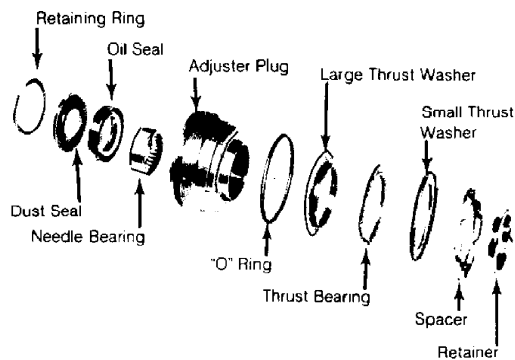

30542

Fig. 9: Exploded View of Adjuster Plug Assembly

### Reassembly

1) Press roller bearing into adjuster plug (identification end facing arbor) until bearing bottoms on input shaft seal bore.

Install input shaft seal with spring in seal facing adjuster plug.

2) Install dust seal into adjuster plug. Rubber face of seal must face away from plug. Install retainer ring. Install adjuster plug "O" ring.

3) Assemble thrust bearing, thrust bearing race, and thrust bearing spacer on adjuster plug. Using a brass or wooden dowel, press bearing retainer into needle bearing bore.

## RACK/PISTON & WORM

### Disassembly

Remove worm, lower thrust bearing and bearing races from rack piston. Remove piston ring and back-up "O" ring from rack/piston. Remove ball return guide clamp, ball return guide and all ball bearings from rack/piston.

### Inspection

1) Clean and dry all parts. Inspect worm and rack/piston grooves for scoring. Inspect ball bearings for damage. If any ball bearings are damaged, replace entire set. Check ball guides for pinching of ends.

2) Inspect lower thrust bearing races for cracking, scoring, or pitting. Replace wormshaft and rack/piston as an assembly if either part is damaged. Inspect rack/piston teeth for chips, cracks, dents or scoring.

### Reassembly

1) Install "O" ring and piston ring onto rack/piston using care not to twist them. Install worm into rack/piston until worm is against piston shoulder. Install ball bearings into rack/piston while slowly rotating worm counterclockwise.

NOTE: See RACK PISTON & WORM ASSEMBLY BALL BEARINGS table for number of balls to be installed. BE SURE to install light and dark colored balls alternately, as Black balls are .0005" smaller than Silver balls.

2) Install correct number of balls in ball guide. Bearings in guide must be in sequence with bearings in rack/piston. Hold balls in place with chassis lubricant and install return ball guide assembly into position.

3) Install clamp and tighten attaching bolts. Alternate light and dark colored balls when installing. See Fig. 10. Insert rack/piston arbor into rack/piston until it contacts worm. Maintain pressure on arbor, and back worm out of rack/piston. DO NOT allow ball bearings to drop out of circuits.

### RACK PISTON & WORM ASSEMBLY BALL BEARINGS TABLE

Application	Rack/Piston	Guide
Jeep .....	18 .....	6

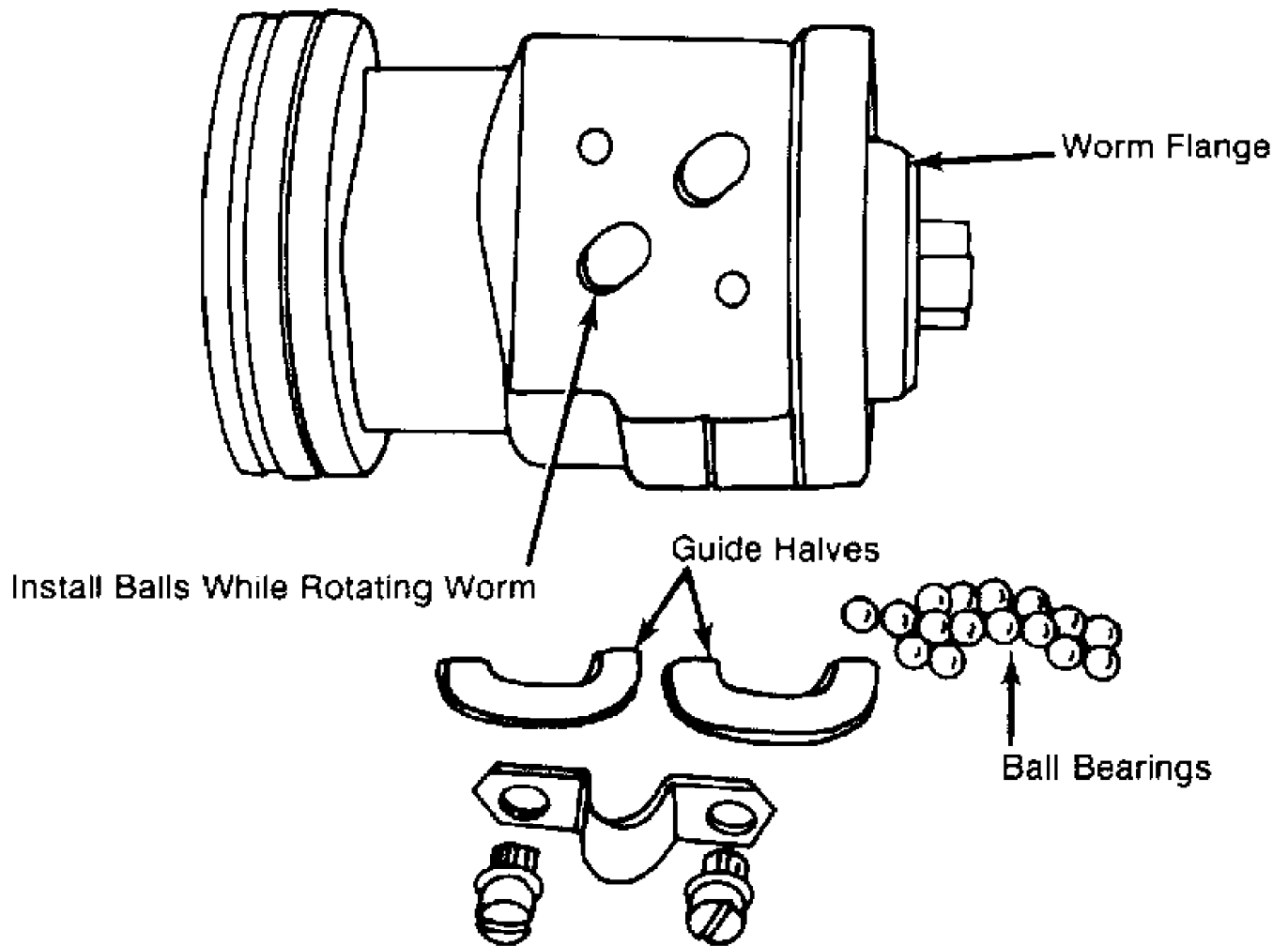

30543

Fig. 10: Installing Ball Bearing into Rack/Piston Assembly

## ROTARY VALVE

NOTE: Complete valve assembly is balanced during assembly. If replacement of any part other than rings or seals is necessary, replace complete assembly.

### Disassembly

1) Remove and discard stub shaft cap "O" ring. Invert valve and lightly tap end of stub shaft against wood block until shaft cap is free of valve body. Pull stub shaft outward until drive pin hole is visible. Depress the pin to remove the stub shaft from the valve body. See Fig. 11.

NOTE: DO NOT pull shaft any further than 1/4" (6 mm) or spool valve may become cocked in valve body.

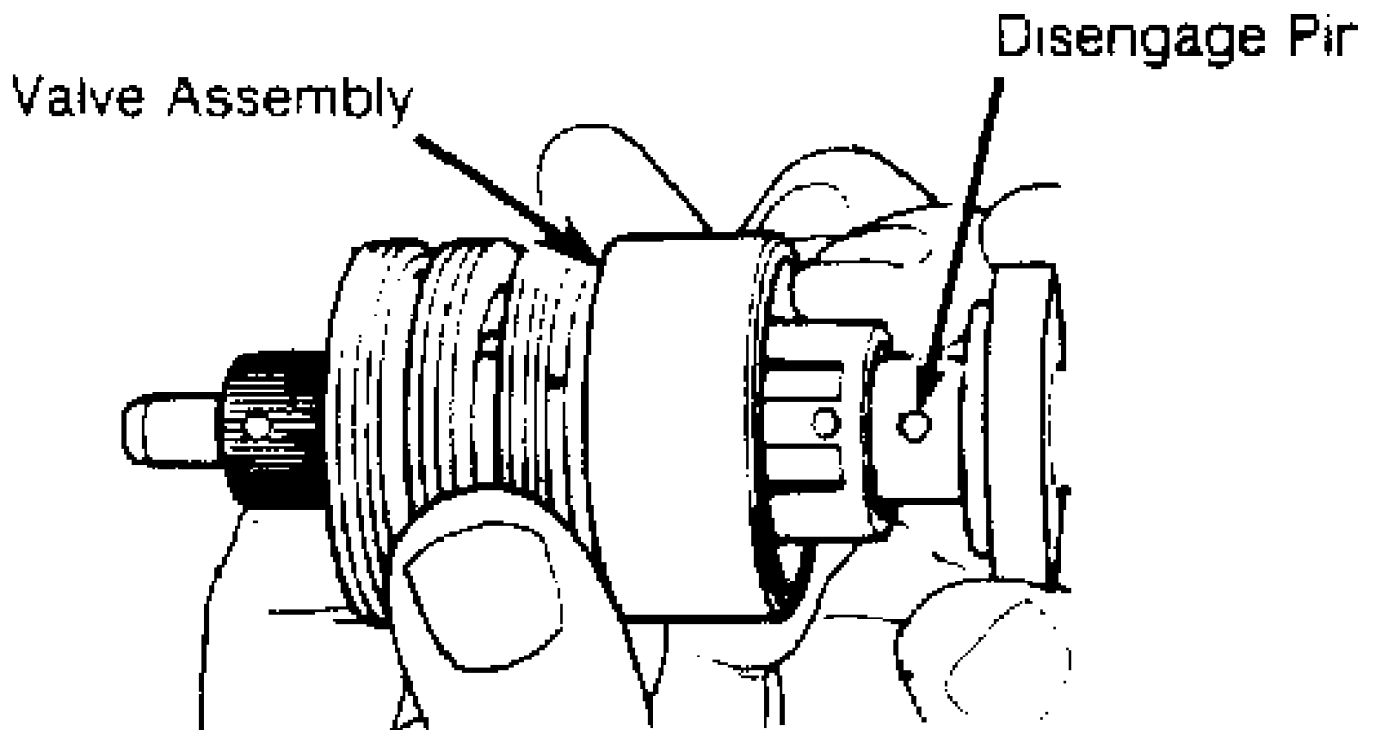

### 30335

Fig. 11: Pulling Shaft from Valve Assembly

2) Disengage drive pin and carefully remove stub shaft from valve body and spool assembly with a twisting motion. If binding occurs, realign valve and try removal again.

CAUTION: DO NOT force stub shaft or spool out of valve body.

3) Remove spool valve from valve body with twisting motion. Remove and discard all "O" rings and Teflon rings.

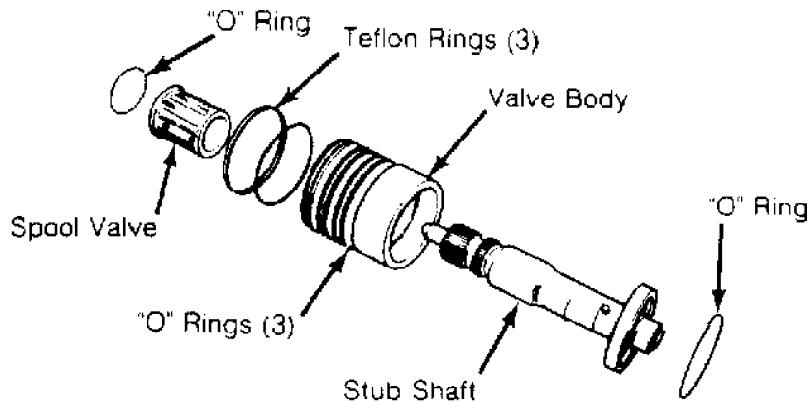

### 30334

Fig. 12: Exploded View of Valve Body Assembly

Reassembly

1) Lubricate all valve body components with power steering fluid. Install replacement back-up "O" rings in seal grooves and

install replacement seal rings over back-up rings. Take care not to damage seal rings during installation.

NOTE: Teflon seal rings may appear to be distorted after installation. However, heat of operation will straighten them.

2) Lubricate replacement spool valve damper "O" ring with petroleum jelly. Install on spool valve. Carefully insert spool valve into valve body.

3) Push spool valve through valve body until locating pin hole is visible at opposite end of valve body and spool valve is flush with the notched end of the valve. Install stub shaft in spool valve and valve body.

4) Be sure stub shaft locating pin is aligned with spool valve locating hole. Align notch in stub shaft cap with stub shaft locating pin and press sub shaft and spool valve into valve body. Install stub shaft cap "O" ring into valve body. See Fig. 13.

CAUTION: Before installing assembled valve body into gear housing, be sure valve body stub shaft locating pin is fully engaged in stub shaft cap notch. DO NOT allow stub shaft to disengage from valve body pin.

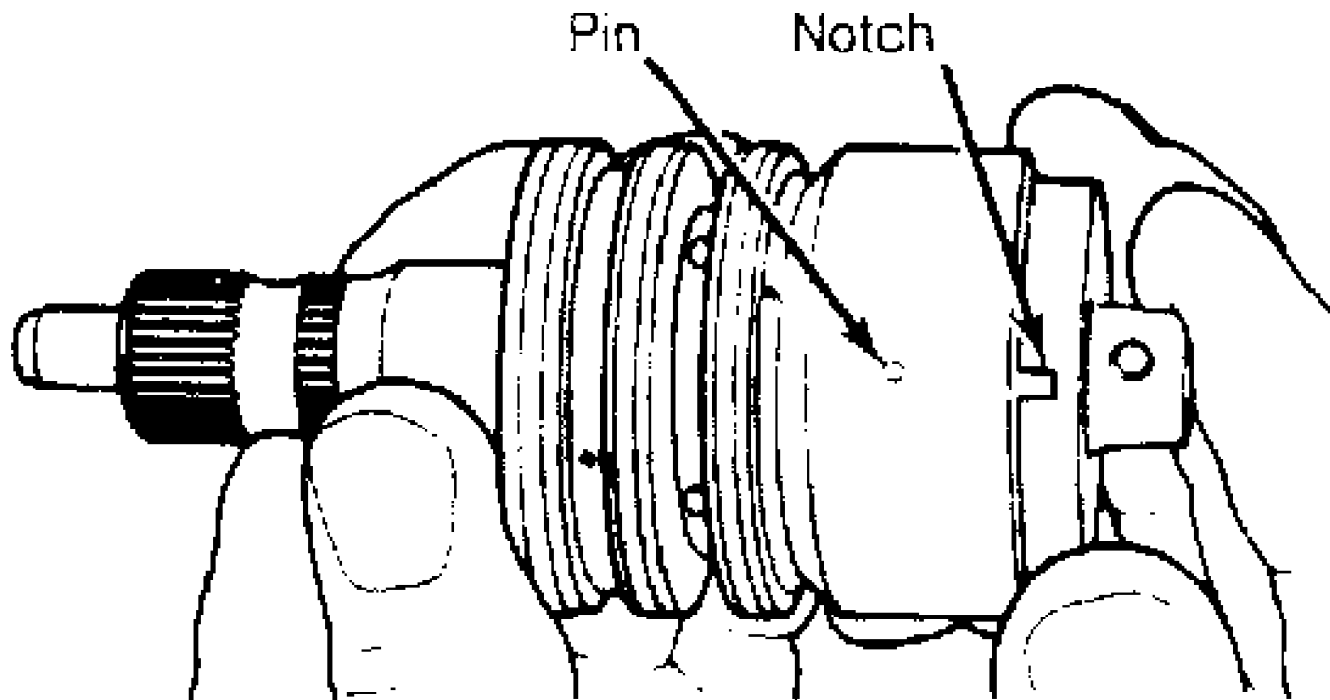

**30336**

Fig. 13: Aligning Pin & Notch for Input (Stub) Shaft  
Stub shaft locating pin must align with spool valve locating hole.

## STEERING GEAR HOUSING

### Disassembly

1) Remove sector shaft seal retaining ring and remove lower steel washer. Remove lower seal, spacer washer and upper seal from housing. Press sector shaft bearing out of housing from lower end.

2) To remove hose connector seat, tap out seat using a 5/16"-

18 thread tap. Thread connector seats ONLY 2-3 threads. Install a bolt with a flat washer and nut into seat.

3) Hold bolt from turning and tighten nut to extract seat from housing. Some steering gear units have metric thread fittings and hose fittings which use "O" ring seals instead of connector seats. Remove check valve and spring from inlet port and discard.

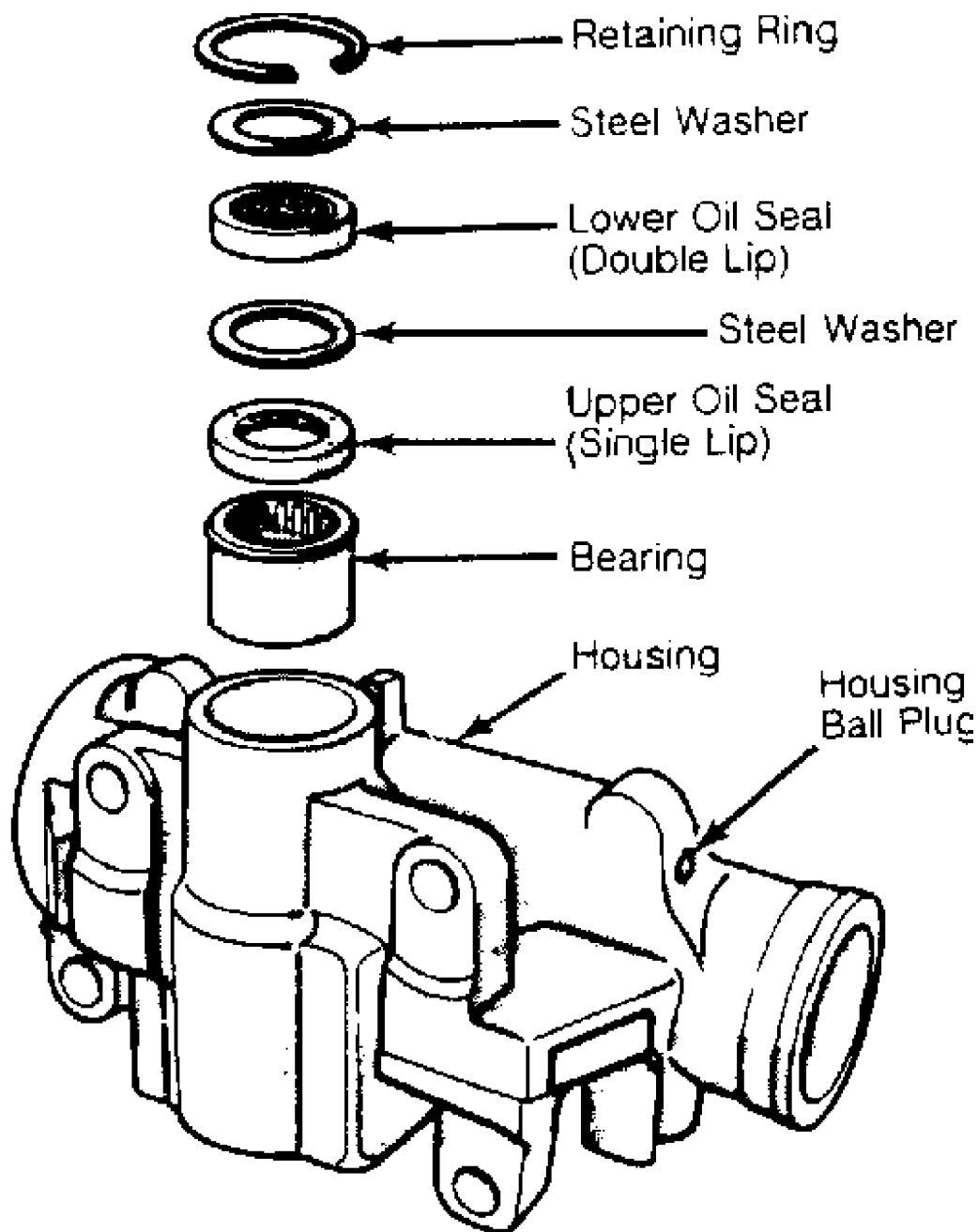

30337

Fig. 14: Gear Housing Seals & Bearing

Inspection

1) Replace housing if bore is severely worn, scored or pitted. Minor scratches may be removed with crocus cloth. Inspect



housing ball plug for fluid leakage. Seat ball plug with blunt punch.

2) Spray ball area with Loctite Solvent 7559 and dry with compressed air. Cover ball area with Loctite Sealant 290. Allow sealant to cure for 2 hours before assembling gear.

3) Inspect all retaining ring, bearing and seal surfaces in housing. Replace housing if any surface is worn or damaged.

#### Reassembly

1) Working from upper end, press a new bearing into housing until it is seated .030" (.76 mm) below shoulder in housing bore. Lubricate new seal with power steering fluid.

2) Install single lipped seal and spacer washer only far enough to provide clearance for next seal, washer and retaining ring. DO NOT bottom seal against housing counterbore.

3) Install double lipped seal and steel washer. Install retaining ring. DO NOT allow seals to contact one another. To ensure proper seal action, be sure there is clearance between them.

4) If port seat was removed, position new spring, check valve, and a new seat over opening in housing. Drive into place using a brass drift.

## TORQUE SPECIFICATIONS

### CHEROKEE, COMANCHE, WAGONEER & WRANGLER

#### TORQUE SPECIFICATIONS (CHEROKEE, COMANCHE, WAGONEER & WRANGLER)

Application	Ft. Lbs. (N.m)
Adjuster Plug Lock Nut .....	80 (108)
Gear Housing-to-Frame Attaching Bolts .....	75 (102)
Pitman Arm Attaching Nut .....	185 (250)
Rack Piston End Plug .....	50 (68)
Sector Shaft Adjuster Lock Nut .....	33 (45)
Side Cover Bolts .....	45 (60)

### GRAND WAGONEER & "J" TRUCK)

#### TORQUE SPECIFICATIONS (GRAND WAGONEER & "J" TRUCK)

Application	Ft. Lbs. (N.m)
Adjuster Plug Lock Nut .....	85 (116)
Gear Housing-to-Frame Attaching Bolts .....	(95)
Pitman Arm Attaching Nut .....	185 (250)
Rack Piston End Plug .....	75 (102)
Sector Shaft Adjuster Lock Nut .....	33 (45)
Side Cover Bolts .....	40 (54)