

TRANSFER CASE - COMMAND TRAC DIAGNOSIS

1988 Jeep Cherokee

1984-90 Drive Axles - Transfer Case - Electronic Diagnosis

Cherokee, Wagoneer, Wrangler (1987-90)

VACUUM CONTROL SYSTEM

The Command-Trac vacuum switch consists of a vacuum control switch on the transfer case, an air vent filter, a vacuum shift motor (located on front axle), a four-wheel drive indicator light and vacuum switch, two vacuum check valves and an interconnecting vacuum harness. See Fig. 1.

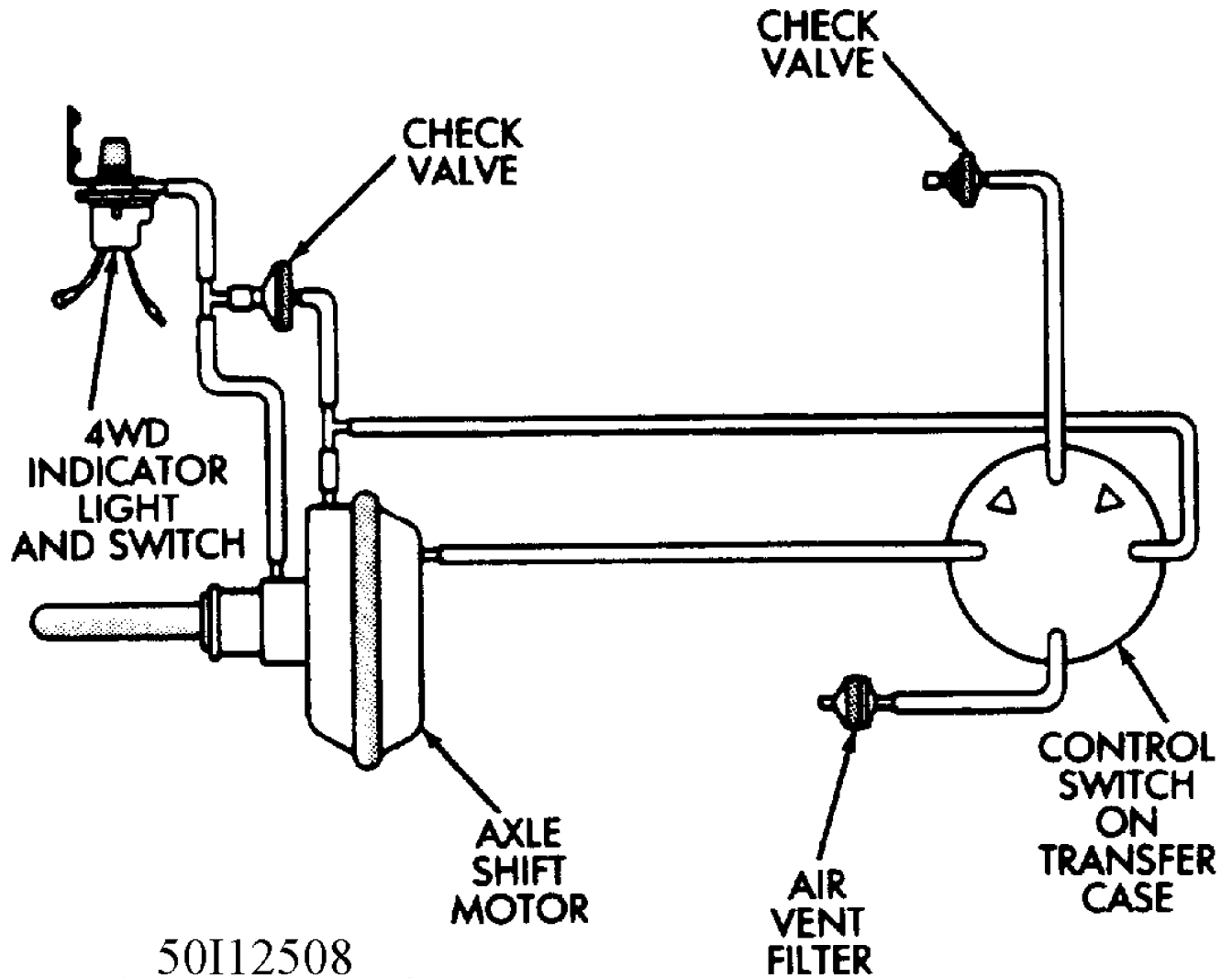

50112508

Fig. 1: Command-Trac Vacuum Control System

AXLE SHIFT MOTOR FUNCTIONAL TEST

1) Raise vehicle. Disconnect vacuum harness from axle shift motor and connect a vacuum pump to vacuum shift motor port. See Fig. 2.

2) Apply 15 in. Hg. (51 kPa) of vacuum to front port and rotate right front wheel to fully disengage outer and intermediate axle shafts (i.g., into two wheel drive operation).

3) The shift motor should maintain vacuum applied to front port for a minimum of 30 seconds. If motor does not maintain vacuum, replace it. If motor does maintain vacuum, proceed to next step.

4) Disconnect vacuum pump from vacuum shift motor front port. See Fig. 2. Connect vacuum pump to vacuum shift motor rear port, cap port for indicator lamp sw., and apply 15 in. Hg (51 kPa) of vacuum to rear port.

5) The shift motor should maintain the vacuum applied to rear port for a minimum of 30 seconds. If shift motor does not maintain vacuum, replace it. If motor does maintain vacuum, proceed to next step.

6) Remove cap from port for indicator lamp sw. and determine if vacuum was present at this port. If vacuum was present, the shift motor functions normally. If vacuum was not present, proceed to next step.

7) Apply 15 in. Hg. (51 kPa) of vacuum to shift motor rear port. Rotate right front wheel as necessary and ensure that outer and intermediate axle shafts are completely engaged. The axles must be completely engaged (i.e. into four-wheel drive operation) to open port for indicator lamp switch.

8) Determine if vacuum is present at port for indicator lamp switch again. If vacuum was present at port, shift motor functions normally. If vacuum was not present at port, replace shift motor.

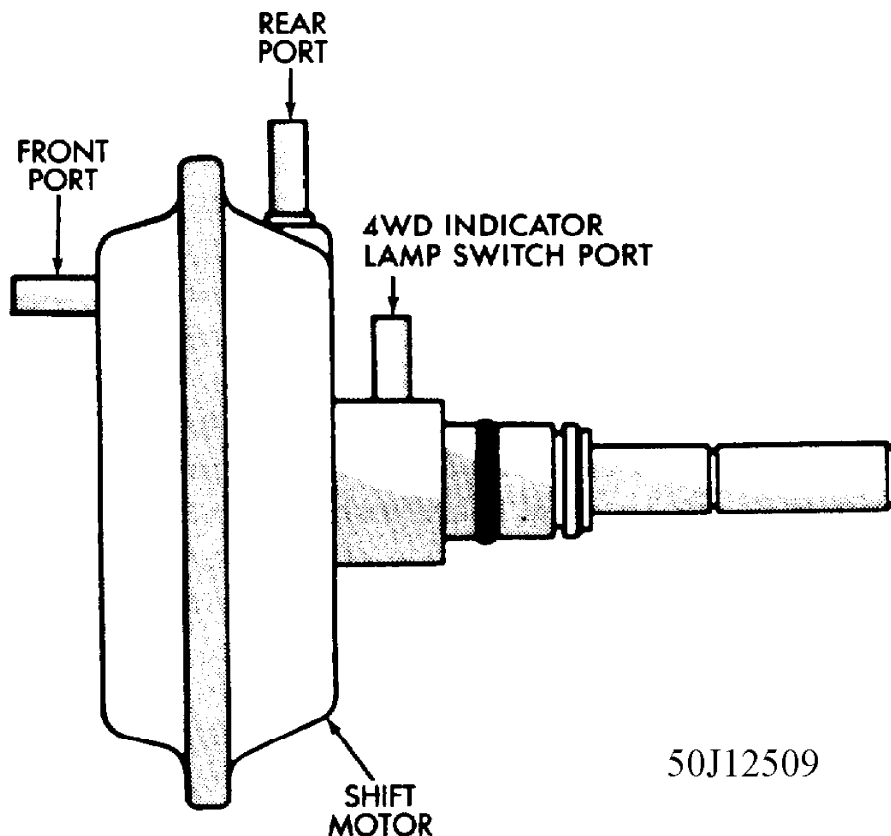

Fig. 2: Axle Vacuum Shift Motor

AXLE SHIFT MOTOR AND HOUSING REMOVAL & INSTALLATION

REMOVAL (60/70 SERIES AND MODEL 81 VEHICLES)

- 1) Raise and support vehicle. Position a drain pan under shift motor housing.
 - 2) Disconnect vacuum harness.
 - 3) Remove housing attaching bolts. Remove housing, motor and shift fork as a unit. See Fig. 3.
 - 4) Mark shift fork and housing for installation reference.
 - 5) Rotate shift motor and remove shift fork and motor retaining snap rings.
 - 6) Remove shift motor from housing.
 - 7) Remove O-ring seal from shift motor shaft. See Fig. 4.
- Discard O-ring seal.

INSTALLATION (60/70 SERIES AND MODEL 81 VEHICLES)

- 1) Add 5 ounces (148 ml) of SAE 75W-90 grade GL 5 gear lubricant to axle through shift motor housing opening.
- 2) Install a replacement O-ring seal on shift motor shaft. See Fig. 4.
- 3) Install shift motor in housing with retaining snap rings and slide shift fork onto shaft with reference mark aligned.
- 4) Engage shift fork with shift collar and install housing attaching bolts. See Fig. 3. Tighten bolts with 101 inch-lbs. (11 N.m) torque.
- 5) Connect vacuum harness to shift motor and lower vehicle.

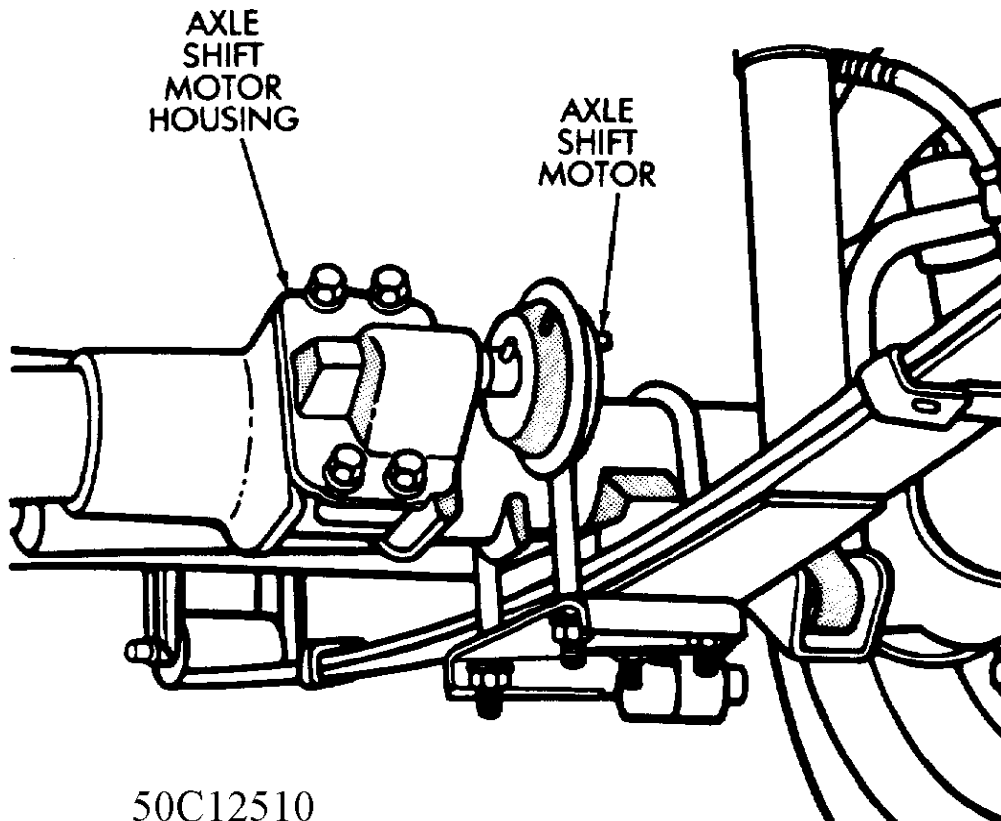

50C12510

Fig. 3: Axle Vacuum Shift Motor and Housing

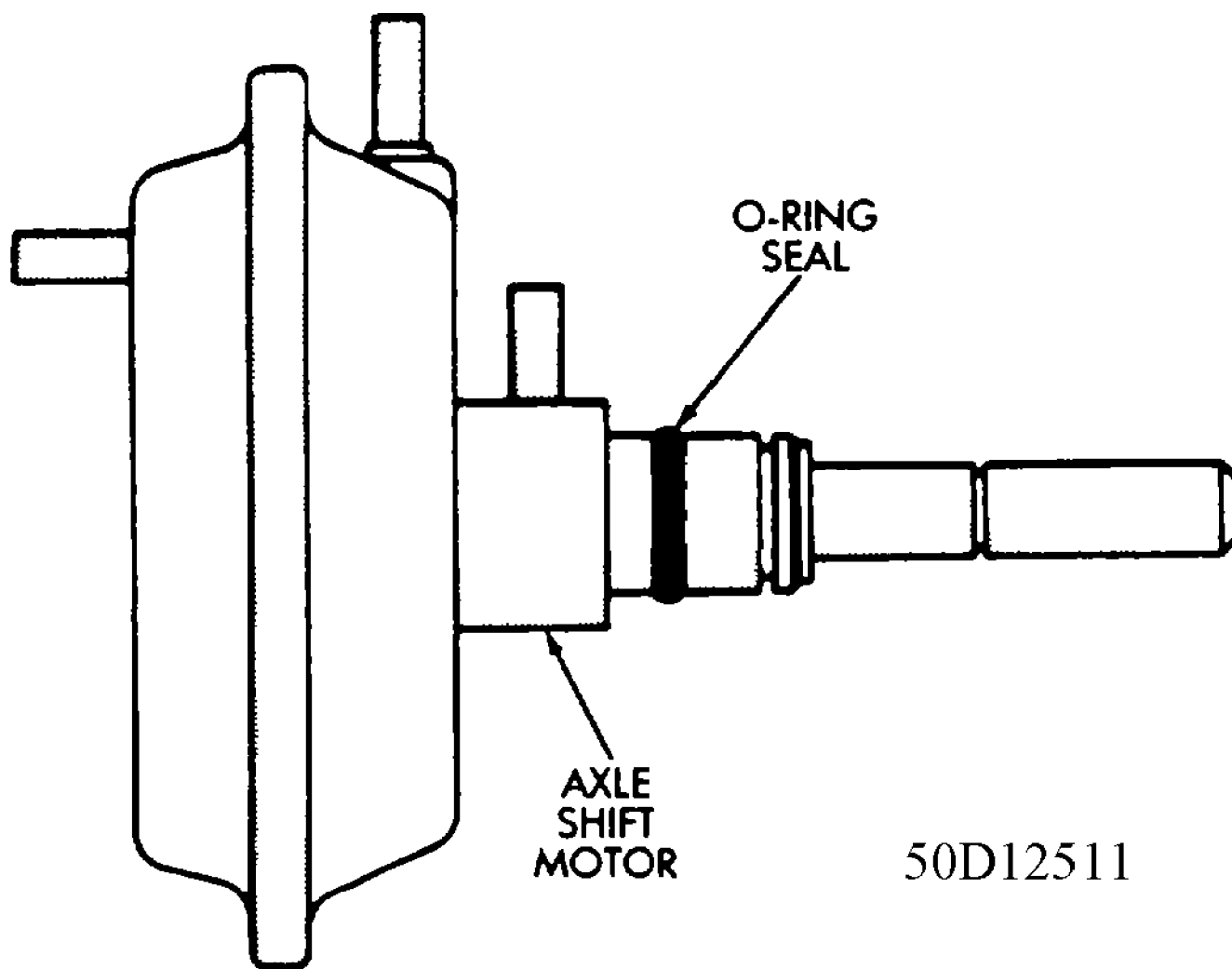

AXLE
SHIFT
MOTOR

O-RING
SEAL

50D12511

Fig. 4: Axle Vacuum Shift Motor Shaft O-Ring Seal