

RECALL 681 - 2.5L ENG OUTSIDE CALIF. CATALYTIC CONV.

1993 Jeep Cherokee

EMISSION RECALL BULLETIN

EMISSIONS RECALL #680 - CATALYTIC CONVERTER

Model(s) : 1991-1995 Jeep Cherokee (XJ)
1991-1995 Jeep Wrangler (YJ)
1991-1992 Jeep Comanche (MJ) Vehicles
Bulletin No.: 681
Date: May, 1996

NOTE: This is an Emission Recall bulletin.

VEHICLES AFFECTED

Vehicles Listed Below Which Are Equipped With a 2.5L Engine and Are Currently Located Outside of California:

- * 1991 through 1995 Model Year Jeep Cherokee (XJ) Vehicles Built Through February 14, 1995 (MOH 021411)
- * 1991 Through 1995 Model Year Jeep Wrangler (YJ) Vehicles Built Through February 7, 1995 (MDH 020712)
- * 1991 and 1992 Model Year Jeep Comanche (MJ) Vehicles

SERVICE INFORMATION

Failure of the catalytic converter on the above listed vehicles, may cause a vehicle to be in violation of U.S. Environmental Protection Agency (EPA) Emissions Standards. To correct this condition, the catalytic converter must be replaced. Vehicles which are located in California will be serviced under California Emissions Recall #680.

Details of this service action are explained in the following sections.

SERVICE PROCEDURE VIDEOTAPE

No videotape of the service procedure for this recall will be provided.

DEALER NOTIFICATION & VEHICLE LIST

INVOLVED DEALERS

Each dealer to whom involved vehicles were invoiced (or the current dealer at the same street address) will receive a copy of this dealer recall notification letter and a list of the involved vehicles by first class mail.

The Vehicle List is arranged in Vehicle Identification Number (VIN) sequence. Owners known to Chrysler are also listed. The lists are for dealer reference in arranging for service of involved vehicles as necessary.

ALL CALIFORNIA DEALERS

Each Jeep & Eagle dealer who does not receive a Vehicle List will receive a copy of this dealer recall notification letter by first class mail.

DIAL SYSTEM FUNCTION 70 AND VIP

All involved vehicles will be entered to DIAL System Function 70 and VIP at the time of recall implementation for dealer inquiry by VIN as needed.

PARTS INFORMATION

IMPORTANT: A quantity of parts will be distributed initially and billed to all involved dealers. This quantity will cover a portion of the total vehicles involved. Additional parts may be ordered as needed to support customer demand.

Each involved dealer, to whom vehicles in the recall were invoiced (or the current dealer at the same street address), will receive enough Catalytic Converter Packages, Recall PN CLER6811 (for 1991 and 1992 model year vehicles), and Recall PN CLKG6812 for (1993, 1994 and 1995 model year vehicles) to service 25% of those vehicles.

Each parts package contains the following components:

CATALYTIC CONVERTER PACKAGES

91/92 MY Vehicles (CLER6811)		93/94/95 MY Vehicles (CKLG6812)	
Qty	Description	Qty	Description
1	Catalytic Converter	1	Catalytic Converter
1	Clamp	2	Clamp
4	Bolts	1	Recall Completion Label
4	Nuts	1	Instruction Sheet
1	Gasket		
1	Recall Completion Label		
1	Instruction Sheet		

OWNER NOTIFICATION & SERVICE SCHEDULING

All involved vehicle owners known to Chrysler are being notified of the service requirement by first class mail. They are requested to schedule appointments for the service with their dealers at the earliest possible date. A copy of the CUSTOMER NOTIFICATION LETTER is in this bulletin.

Enclosed with each owner notification is an Owner Notification Form. The involved vehicle and recall are identified on the form for owner or dealer reference as needed.

3. Remove and discard the nuts, bolts and gasket at the front of the converter and the exhaust pipe clamp at the rear (see Fig. 1).

NOTE: Use penetrating oil if necessary.

4. Place a block of wood against the rear of the converter and drive the clamp converter forward to disengage the alignment tab on the converter pipe from the alignment slot on the muffler.

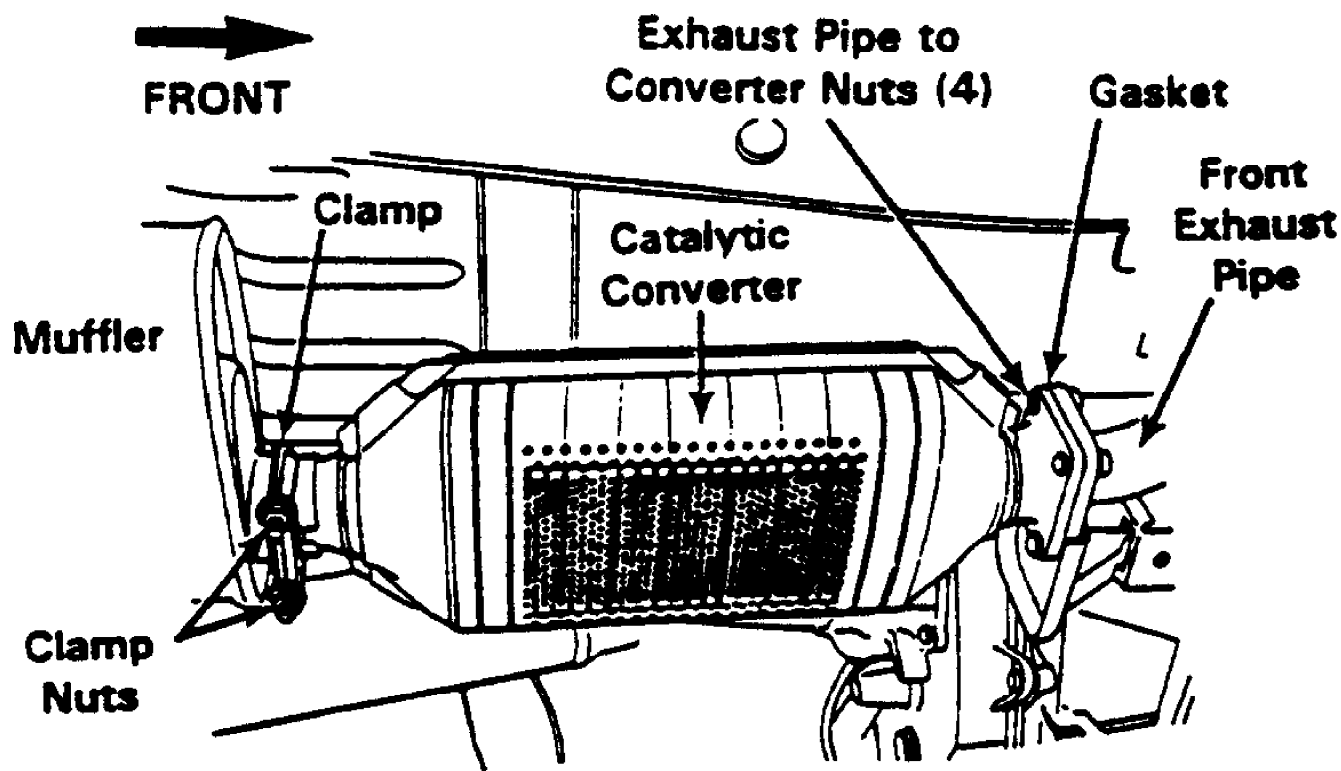

97C55550

Fig. 1: Removing Converter and Exhaust Pipe Clamp

NOTE: If the converter does not move forward, it may be necessary to heat the converter to muffler connection with an oxyacetylene torch until the metal becomes cherry red.

5. Twist the converter back and forth to separate it from the muffler.
6. Install the new converter into the muffler until the alignment tab is inserted into the alignment slot.
7. Using the provided gasket, nuts and bolts, attach the converter to the front exhaust pipe. Do not tighten the bolts.
8. Install and tighten the new exhaust pipe clamp, at the muffler to converter connection, to 40 ft-lbs (57 N-m).
9. Tighten the converter to front exhaust pipe bolts to 25 ft-lbs (34 N-m).
10. On Wrangler (YJ) vehicles:
Install the skid plate.
11. Lower vehicle.

SERVICE PROCEDURE FOR 1993, 1994 AND 1995 MY VEHICLES

A. REPLACE CATALYTIC CONVERTER

WARNING: IF TORCHES ARE USED WHEN WORKING ON THE EXHAUST SYSTEM, DO NOT ALLOW THE FLAME NEAR THE FUEL LINES.

1. Raise vehicle on an appropriate hoist.
2. On Wrangler (YJ) vehicles: Support the transmission and remove the skid plate.
3. Remove the U-bolt clamps from the exhaust pipe and muffler connections at the front (see Fig. 2 and 3) and rear (see Fig. 4) of the catalytic converter.

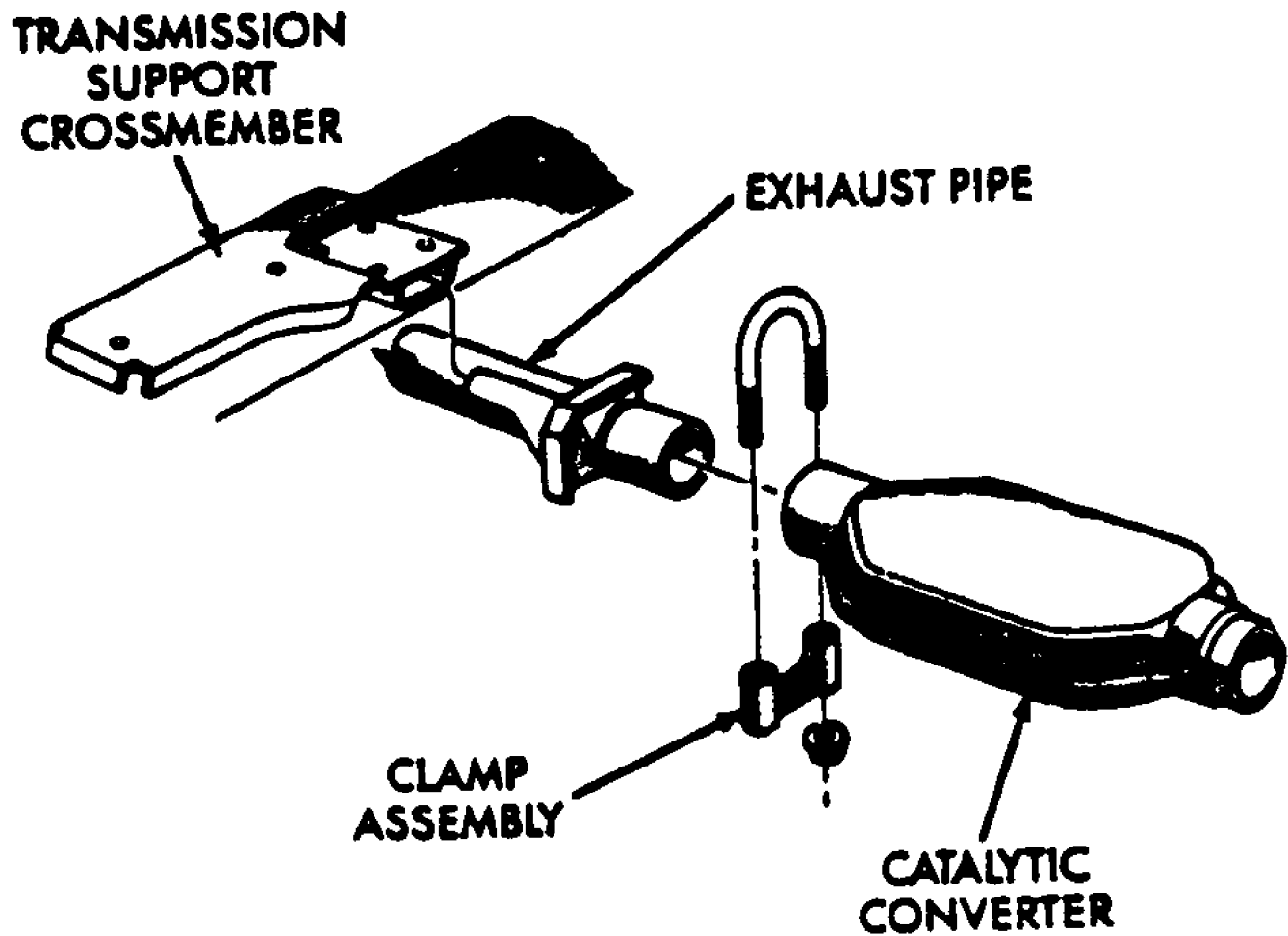

97C56921

Fig. 2: U-Bolt Clamps and Muffler Connections (XJ Vehicles)

YJ VEHICLES

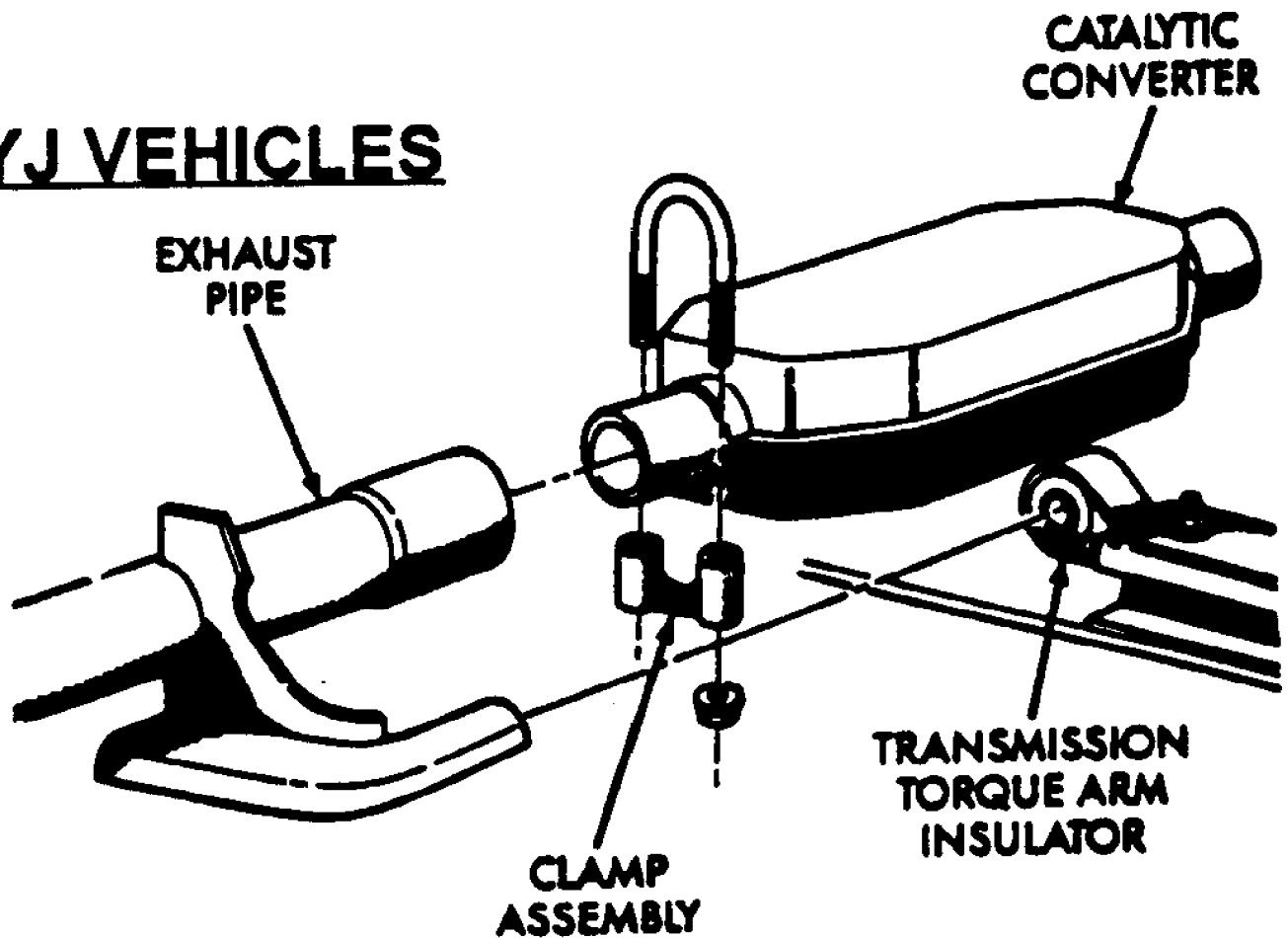

97H55548

Fig. 3: U-Bolt Clamps and Muffler Connections (YJ Vehicles)

4. Heat the catalytic converter to muffler connection with an oxyacetylene torch until the metal becomes cherry red.
5. While the metal is still cherry red, twist the muffler assembly back and forth to separate it from the converter.
6. Disconnect the front exhaust pipe from the catalytic converter. If necessary, heat the pipe connection as described above.
7. Connect the supplied catalytic converter to the front exhaust pipe. Use one of the supplied clamps and tighten the nuts to 45 ft-lbs (61 N.m).
8. Install the muffler on to the catalytic converter until the alignment tab is inserted into the alignment slot.
9. Install and tighten the new exhaust pipe clamp, at the muffler to converter connection, to 45 ft-lbs (61 Nm). See Fig. 4.

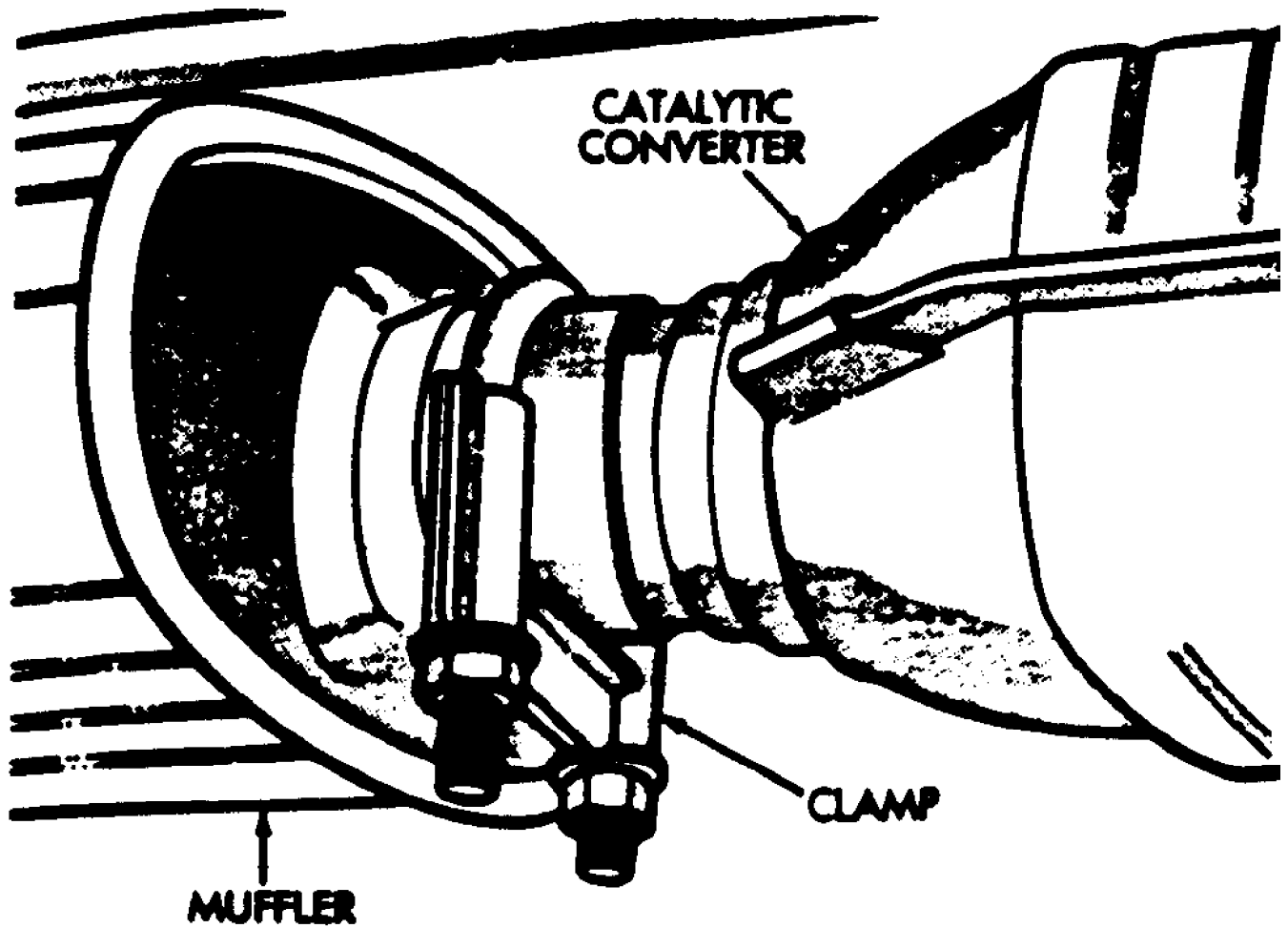

97155549

Fig. 4: U-Bolt Clamps and Muffler Connections (Rear)

- 10. On Wrangler (YJ) vehicles:
Install the skid plate.
- 11. Lower the vehicle.

COMPLETION REPORTING AND REIMBURSEMENT

Claims for vehicles which have been serviced must be submitted on the DIAL System Claims submitted will be used by Chrysler to record recall service completions and provide dealer payments.

Use the following labor operation number and time allowance:

	Labor Operation Number	Time Allowance
Replace Catalytic Converter	11681182	0.7 Hours

Add the cost of the recall parts package plus applicable dealer

allowance to your claim.

PARTS RETURN

Removed catalytic converters must be returned to the Warranty Material Return Center.

NOTE: See Warranty Policy and Procedure Manual, Chapter 6, Subsection H for complete recall claim processing and material return instructions.

VEHICLE NOT AVAILABLE

If a vehicle is not available for service for a known reason, let us know by filling out the pre-addressed Vehicle Disposition Form portion of the Owner Notification Form, or describe the reason on a postcard and mail to:

Chrysler Corporation
CIMS 482-00-85
800 Chrysler Drive East
Auburn Hills, Michigan 48326-2757

Following the above procedures will expedite the processing of your claim.

If you have any questions or need assistance in completing this action, please contact your Zone Service Office.

Customer Services Field Operations
Chrysler Corporation

CUSTOMER NOTIFICATION LETTER

EMISSIONS RECALL TO REPLACE YOUR VEHICLE'S CATALYTIC CONVERTER

Dear Jeep Vehicle Owner:

Chrysler has determined that some 1991 through 1995 Jeep Cherokee, Comanche and Wrangler vehicles equipped with a 2.5L engine, may be in violation of Federal Emissions Standards.

The Problem is... The catalytic converter on your vehicle (identified on the enclosed form), may be susceptible to failure. Failure of the catalytic converter could result in hydrocarbon (HC), carbon monoxide (CO) and oxides of nitrogen (NOx) levels above the allowable limits which were established to protect the public health from the dangers of air pollution.

What Chrysler and your dealer will do... Chrysler will repair your vehicle free of charge (parts and labor). To do this, your dealer will replace the catalytic converter. The work will take about one hour to complete. However, additional time may be necessary depending on how dealer appointments are scheduled and processed.

What you must do... * Simply contact your Jeep & Eagle dealer to schedule a service appointment. Ask the dealer to

hold the parts for your vehicle or to order them before your appointment.

- * Bring the enclosed Owner Notification Form with you to your dealer, It explains the required service to your dealer.

If you need help...

If you have trouble getting your vehicle repaired, please call the Chrysler Customer Center, toll free, at 1-800-853-i403. A representative will assist you in getting your vehicle repaired. If you are still unable to obtain the repair as described in this letter within a reasonable time, you may also contact the Vehicle Programs and Compliance Division of the Environmental Protection Agency (6405J), 401 M Street, S.W. Washington, D.C. 20460.

In order to ensure your full protection under the emission warranty made applicable to your vehicle under Federal law, and your right to participate in future recalls, it is recommended that you have your vehicle serviced as soon as possible. Failure to do so could legally be determined to be a lack of proper maintenance of your vehicle. Further, without this repair your vehicle may fail a state or local emission inspection test.

We're sorry for any inconvenience, but trust that you understand our interest in clean air and your continuing satisfaction with our product. Thanks for your attention to this important matter.

Customer Services Field Operations
Chrysler Corporation