

FUEL SYSTEM

CONTENTS

	page		page
ACCELERATOR PEDAL AND THROTTLE CABLE ...	16	MULTI-PORT FUEL INJECTION (MFI)—	
FUEL DELIVERY SYSTEM	2	COMPONENT REMOVAL/INSTALLATION ...	54
FUEL TANKS	12	MULTI-PORT FUEL INJECTION (MFI)—	
GENERAL INFORMATION	1	GENERAL DIAGNOSIS	32
MULTI-PORT FUEL INJECTION (MFI)—COMPO-		SPECIFICATIONS	62
NENT DESCRIPTION/SYSTEM OPERATION .	17		

GENERAL INFORMATION

Throughout this group, references are made to particular vehicle models by alphabetical designation or by the particular vehicle nameplate. A chart showing a breakdown of the alphabetical designations is included in the Introduction section at the beginning of this manual.

The **Fuel System** consists of: the fuel tank, an electric (fuel tank mounted) fuel pump and a fuel filter. It also consists of fuel tubes/lines/hoses, vacuum hoses, throttle body and fuel injectors.

The **Fuel Delivery System** consists of: the electric fuel pump, fuel filter, fuel tubes/lines/hoses, fuel rail, fuel injectors and fuel pressure regulator.

A **Fuel Return System** is used on all vehicles. The system consists of: the fuel tubes/lines/hoses that route fuel back to the fuel tank.

The **Fuel Tank Assembly** consists of: the fuel tank, filler tube, fuel gauge sending unit/electric fuel pump module, a pressure relief/rollover valve and a pressure-vacuum filler cap.

Also to be considered part of the fuel system is the **Evaporation Control System**. This is designed to reduce the emission of fuel vapors into the atmosphere. The description and function of the Evaporative Control System is found in Group 25, Emission Control Systems.

FUEL USAGE STATEMENT

Your vehicle was designed to meet all emission regulations and provide excellent fuel economy using high quality unleaded gasoline. Only use unleaded gasolines having a minimum posted octane of 87.

If your vehicle develops occasional light spark knock (ping) at low engine speeds, this is not harmful. However, **continued heavy knock at high speeds can cause damage and should be reported to your dealer immediately.** Engine dam-

age as a result of heavy knock operation may not be covered by the new vehicle warranty.

In addition to using unleaded gasoline with the proper octane rating, **those that contain detergents, corrosion and stability additives are recommended.** Using gasolines that have these additives will help improve fuel economy, reduce emissions and maintain vehicle performance. Generally, premium unleaded gasolines contain more additive than regular unleaded gasolines.

Poor quality gasoline can cause problems such as hard starting, stalling and stumble. If you experience these problems, use another brand of gasoline before considering service for the vehicle.

GASOLINE/OXYGENATE BLENDS

Some fuel suppliers blend unleaded gasoline with materials that contain oxygen such as alcohol, MTBE and ETBE. The type and amount of oxygenate used in the blend is important. The following are generally used in gasoline blends:

ETHANOL

Ethanol (Ethyl or Grain Alcohol) properly blended, is used as a mixture of 10 percent ethanol and 90 percent gasoline. **Gasoline with ethanol may be used in your vehicle.**

METHANOL

CAUTION: DO NOT USE GASOLINES CONTAINING METHANOL. Use of methanol/gasoline blends may result in starting and driveability problems. In addition, damage may be done to critical fuel system components.

Methanol (Methyl or Wood Alcohol) is used in a variety of concentrations blended with unleaded gaso-

line. You may encounter fuels containing 3 percent or more methanol along with other alcohols called co-solvents.

Problems that are the result of using methanol/gasoline blends are not the responsibility of Chrysler Corporation. They may not be covered by the vehicle warranty.

MTBE/ETBE

Gasoline and MTBE (Methyl Tertiary Butyl Ether) blends are a mixture of unleaded gasoline and up to 15 percent MTBE. Gasoline and ETBE (Ethyl Tertiary Butyl Ether) are blends of gasoline and up to 17 percent ETBE. Gasoline blended with MTBE or ETBE may be used in your vehicle.

CLEAN AIR GASOLINE

Many gasolines are now being blended that contribute to cleaner air, especially in those areas of the country where air pollution levels are high. These new blends provide a cleaner burning fuel and some are referred to as **Reformulated Gasoline**.

In areas of the country where carbon monoxide levels are high, gasolines are being treated with oxygenated materials such as MTBE, ETBE and ethanol.

Chrysler Corporation supports these efforts toward cleaner air and recommends that you use these gasolines as they become available.

FUEL DELIVERY SYSTEM

INDEX

	page		page
Fuel Filter	8	Fuel Pump Module	2
Fuel Pressure Leak Down Test	7	Fuel System Pressure Test	5
Fuel Pressure Release Procedure	5	Fuel Tubes/Lines/Hoses and Clamps	9
Fuel Pump Capacity Test	7	Quick-Connect Fittings	9
Fuel Pump Electrical Control	5		

FUEL PUMP MODULE

The fuel pump module is installed in the top of the fuel tank. The fuel pump module contains the following components:

- Electric fuel pump
- Fuel pump reservoir
- In-tank fuel filter
- Fuel gauge sending unit
- Fuel supply and return tube connections

The fuel pump used on all vehicles is a gear/rotor type pump. It is driven by a permanent magnet 12 volt electric motor that is immersed in the fuel tank. The electrical pump is integral with the fuel sender unit. The pump/sender assembly is installed inside the fuel tank.

The fuel pump has a check valve at the outlet end that consists of a ball held against a seat by force applied from a spring. When the pump is operating, fuel pressure overcomes spring pressure and forces the ball off its seat, allowing fuel to flow. When the pump is not operating, spring pressure forces the ball back against the seat preventing fuel backflow through the pump.

Fuel system pressure is maintained at approximately 214 kPa (31 psi). This is when the pump is operating and vacuum is supplied to the fuel pressure regulator. If vacuum is not supplied to the pressure regulator, fuel pressure will be approximately 55-69 kPa (8-10 psi) higher. This may be due to a broken or clogged vacuum line. When the fuel pump

is not operating, system fuel pressure of 131-269 kPa (19-39 psi) is maintained. This is done by the fuel pump outlet check valve and the vacuum assisted fuel pressure regulator.

REMOVAL—XJ MODELS

The fuel pump/gauge sender unit assembly can be removed from the fuel tank without removing the tank from the vehicle.

WARNING: THE FUEL SYSTEM IS UNDER A CONSTANT PRESSURE (EVEN WITH THE ENGINE OFF). BEFORE SERVICING THE FUEL PUMP MODULE, THE FUEL SYSTEM PRESSURE MUST BE RELEASED. REFER TO THE FUEL PRESSURE RELEASE PROCEDURE IN THIS GROUP.

WARNING: EXTINGUISH ALL TOBACCO SMOKING PRODUCTS BEFORE SERVICING THE FUEL SYSTEM. KEEP OPEN FLAME AWAY FROM FUEL SYSTEM COMPONENTS.

- (1) Remove fuel filler cap. Perform the Fuel Pressure Release Procedure as outlined in this group.
- (2) Disconnect negative battery cable.
- (3) Using an approved portable gasoline siphon/storage tank, drain fuel tank until fuel level is below one quarter (1/4) full.
- (4) Raise and support vehicle.

WARNING: WRAP SHOP TOWELS AROUND FUEL HOSES TO ABSORB ANY FUEL SPILLAGE DURING FUEL TANK REMOVAL.

(5) Disconnect fuel vent supply and return tubes from fittings on fuel pump module.

(6) Disconnect fuel pump module electrical harness connector from main harness.

(7) Using a brass punch and hammer, remove fuel pump module lock ring by carefully tapping it counterclockwise (Fig. 1).

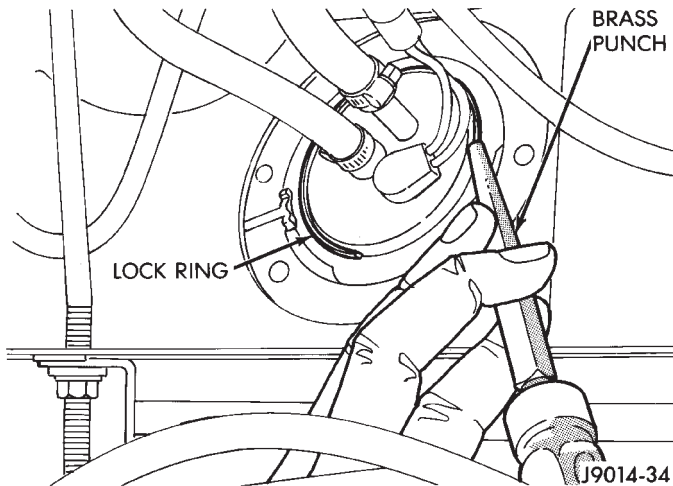

Fig. 1 Removing Lock Ring—XJ Models—Typical

(8) Remove fuel pump module and O-ring seal. Discard old O-ring and fuel pump module inlet filter.

DISASSEMBLY—XJ MODELS

(1) Remove and discard fuel pump inlet filter.

The wire terminals to the fuel pump motor are different in size and cannot be connected to the wrong terminal.

(2) Disconnect fuel pump terminal wires.

(3) Remove fuel pump outlet hose and clamp. Replace the hose if it shows any signs of fatigue or failure.

(4) Remove fuel pump top mounting bracket nut. Remove fuel pump (Fig. 2).

ASSEMBLY—XJ MODELS

Whenever the fuel pump is replaced, the fuel pump inlet filter (sock) must also be replaced.

(1) Place fuel pump top mounting bracket over top of pump.

(2) Position fuel pump into lower bracket. Slide stud of top bracket through hole in fuel pump side bracket. Tighten fuel pump top mounting nut.

(3) Install new fuel pump outlet hose. Secure with new clamps.

(4) Connect wire terminals to motor.

(5) Install new fuel pump inlet filter.

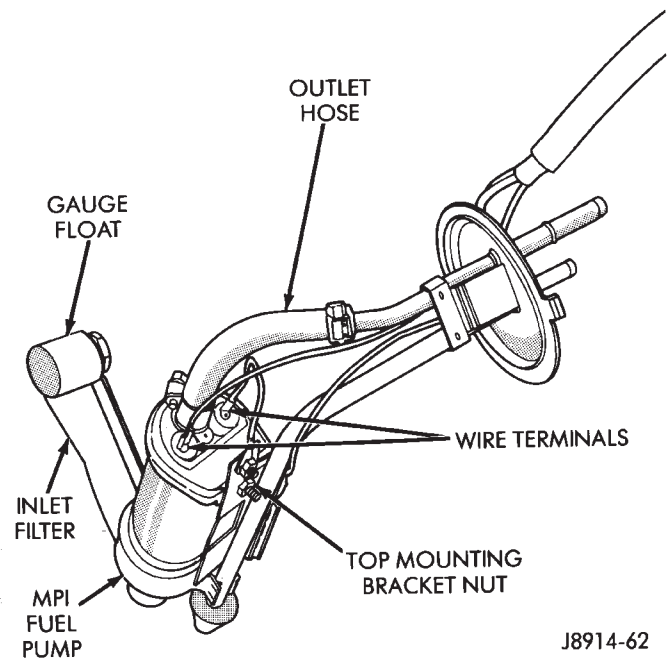

Fig. 2 Fuel Pump Module—XJ Models—Disassemble/Assemble

INSTALLATION—XJ MODELS

Whenever the fuel pump is replaced, the fuel pump inlet filter must also be replaced.

(1) Install new fuel pump inlet filter onto fuel pump.

(2) Install fuel pump module assembly and new O-ring seal. The rubber stopper on the end of the fuel return tube of the assembly must be inserted into the cup in the fuel tank reservoir (Fig. 3).

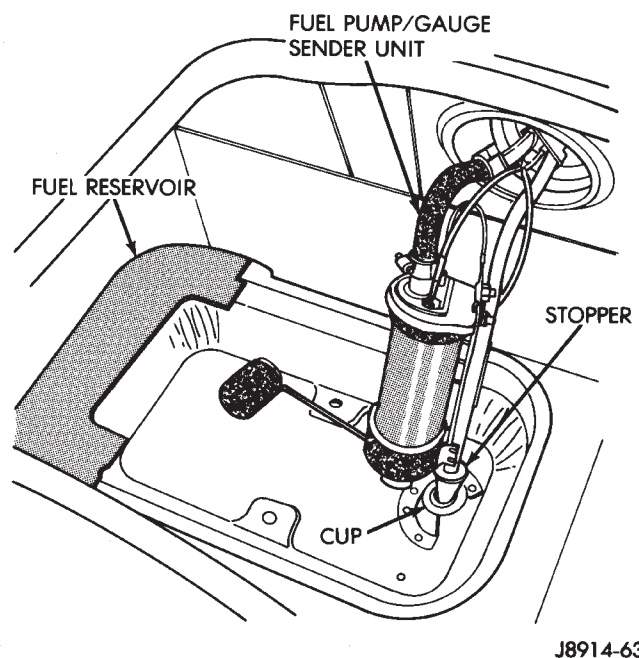

Fig. 3 Fuel Pump Module—XJ Models—Installation

(3) Using a brass punch and a hammer, install lock ring. Carefully tap lock ring clockwise until it seats against stop on fuel tank.

(4) Connect fuel supply and return hoses to fittings on fuel pump module. Tighten hose clamps.

(5) Connect fuel pump module electrical harness connector to main harness connector.

(6) Lower vehicle.

(7) Fill fuel tank. Install fuel tank cap.

(8) Connect negative battery cable.

(9) Start vehicle and inspect for leaks.

REMOVAL—YJ MODELS

The fuel tank must be removed to remove the fuel pump module.

WARNING: THE FUEL SYSTEM IS UNDER A CONSTANT PRESSURE (EVEN WITH THE ENGINE OFF). BEFORE SERVICING THE FUEL PUMP MODULE, THE FUEL SYSTEM PRESSURE MUST BE RELEASED. REFER TO THE FUEL PRESSURE RELEASE PROCEDURE IN THIS GROUP.

WARNING: EXTINGUISH ALL TOBACCO SMOKING PRODUCTS BEFORE SERVICING THE FUEL SYSTEM. KEEP OPEN FLAME AWAY FROM FUEL SYSTEM COMPONENTS.

- (1) Remove negative battery cable.
- (2) Remove fuel filler cap. Perform the Fuel Pressure Release Procedure as outlined in this group.
- (3) Remove fuel tank. Refer to Fuel Tank Removal—YJ Models.
- (4) Remove fuel pump module assembly.
- (5) Remove mounting screws. Lift assembly and gasket out of fuel tank. Discard old gasket (Fig. 4).

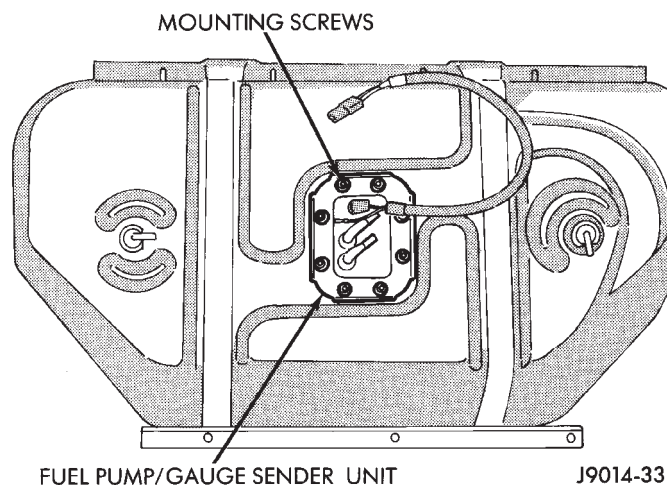

Fig. 4 Fuel Pump Module—Remove/Install—YJ Models

- (6) Remove and discard fuel pump inlet filter.

DISASSEMBLY—YJ MODELS

- (1) Remove and discard fuel pump inlet filter (Fig. 5).

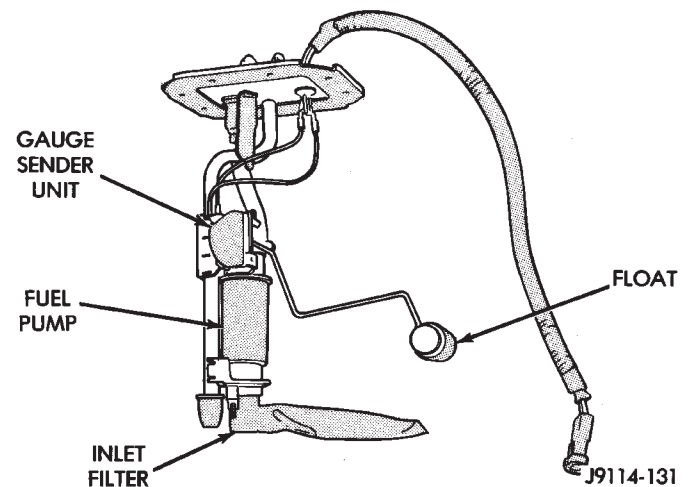

Fig. 5 Fuel Pump Module—YJ Models

The wire terminals to the fuel pump motor are different in size and cannot be connected to the wrong terminal.

- (2) Disconnect fuel pump terminal wires from pump.
- (3) Remove fuel pump outlet hose and clamp (Fig. 6). Replace the hose if it shows any signs of fatigue or failure.
- (4) Remove fuel pump top mounting bracket nut (Fig. 6). Remove fuel pump.

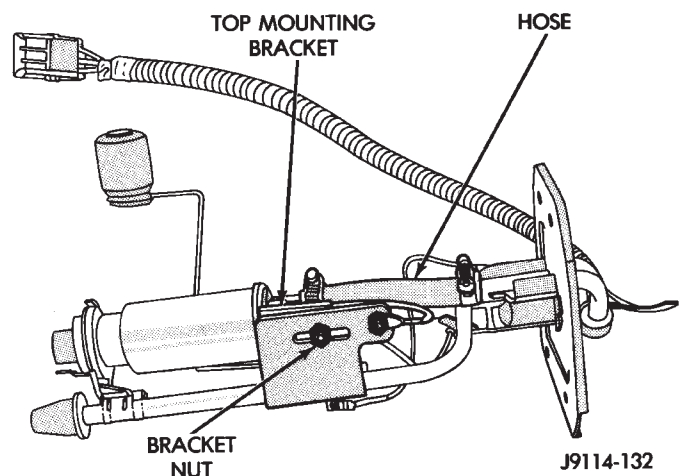

Fig. 6 Fuel Pump Removal/Installation—YJ Models

ASSEMBLY—YJ MODELS

Whenever the fuel pump is replaced, the fuel pump inlet filter (sock) must also be replaced.

- (1) Place fuel pump top mounting bracket over top of pump.
- (2) Position fuel pump into lower bracket. Slide stud of top bracket through hole in fuel pump side bracket. Tighten fuel pump top mounting nut.

- (3) Install new fuel pump outlet hose. Secure with new clamps.
- (4) Connect wire terminals to motor.
- (5) Install new fuel pump inlet filter.

INSTALLATION—YJ MODELS

- (1) Install a new fuel pump inlet filter.
- (2) Install fuel pump module assembly with a new gasket between the assembly and tank. Tighten mounting screws to 2 N·m (18 in. lbs.) torque.
- (3) Install fuel tank. Refer to Fuel Tank Installation—YJ Models.
- (4) Fill fuel tank. Install fuel tank cap.
- (5) Install negative battery cable.
- (6) Start vehicle and check for leaks.

FUEL PUMP ELECTRICAL CONTROL

For an electrical operational description of the fuel pump, refer to the MFI System—Component Description/System Operation section of this group. See Automatic Shut Down (ASD) Relay—PCM Output.

For the 1994 model year, the ballast resistor and ballast resistor bypass relay are no longer used to control the fuel pump circuit.

FUEL PRESSURE RELEASE PROCEDURE

WARNING: THE FUEL SYSTEM IS UNDER CONSTANT FUEL PRESSURE (EVEN WITH THE ENGINE OFF) OF APPROXIMATELY 131-269 KPA (19-39 PSI). THIS PRESSURE MUST BE RELEASED BEFORE SERVICING ANY FUEL SUPPLY OR FUEL RETURN SYSTEM COMPONENT.

- (1) Disconnect negative battery cable.
- (2) Remove fuel tank filler neck cap to release fuel tank pressure.

WARNING: DO NOT ALLOW FUEL TO SPILL ONTO THE ENGINE INTAKE OR EXHAUST MANIFOLDS. PLACE SHOP TOWELS UNDER AND AROUND THE PRESSURE PORT TO ABSORB FUEL WHEN THE PRESSURE IS RELEASED FROM THE FUEL RAIL.

WARNING: WEAR PROPER EYE PROTECTION WHEN RELEASING FUEL SYSTEM PRESSURE.

- (3) Remove protective cap from pressure test port on the fuel rail (Fig. 7).
- (4) Obtain the fuel pressure gauge/hose assembly from fuel pressure gauge tool set 5069. Remove the gauge from the hose.
- (5) Place one end of hose (gauge end) into an approved gasoline container.
- (6) Place a shop towel under the test port.
- (7) To release fuel pressure, screw the other end of hose onto the fuel pressure test port.

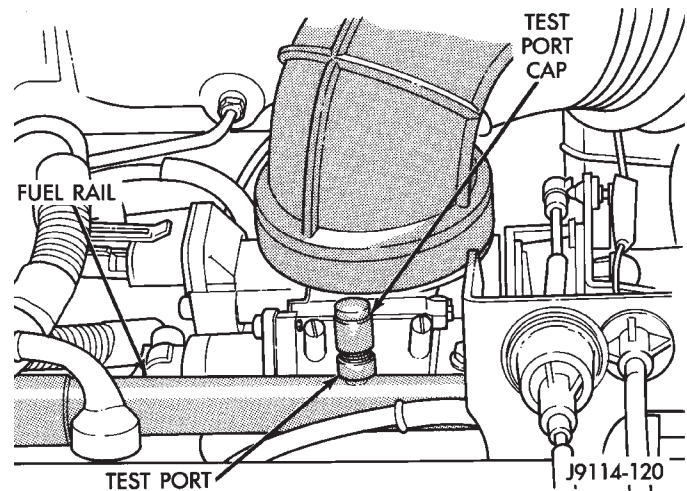

Fig. 7 Pressure Test Port—Typical

- (8) After fuel pressure has been released, remove the hose from the test port.
- (9) Install protective cap to fuel test port.

FUEL SYSTEM PRESSURE TEST

The fuel system is equipped with a vacuum assisted fuel pressure regulator (Fig. 8). With engine at idle speed, system fuel pressure should be approximately 214 kPa (31 psi) with the vacuum line connected to the regulator. With the vacuum line disconnected from the regulator, fuel pressure should be approximately 269 kPa (39 psi). This is 55-69 kPa (8-10 psi) higher.

- (1) Remove the protective cap at the fuel rail (Fig. 7). Connect the 0-414 kPa (0-60 psi) fuel pressure gauge (from Gauge Set 5069) to test port pressure fitting on fuel rail (Fig. 9).

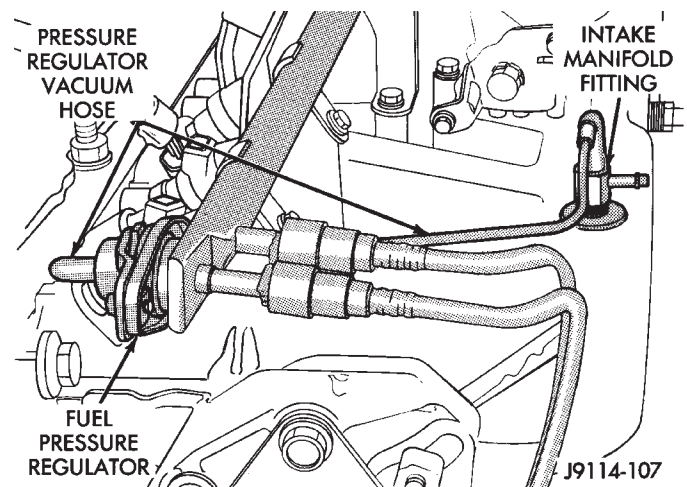

Fig. 8 Fuel Pressure Regulator—Typical

- (2) Note pressure gauge reading. Fuel pressure should be approximately 214 kPa (31 psi) at idle.

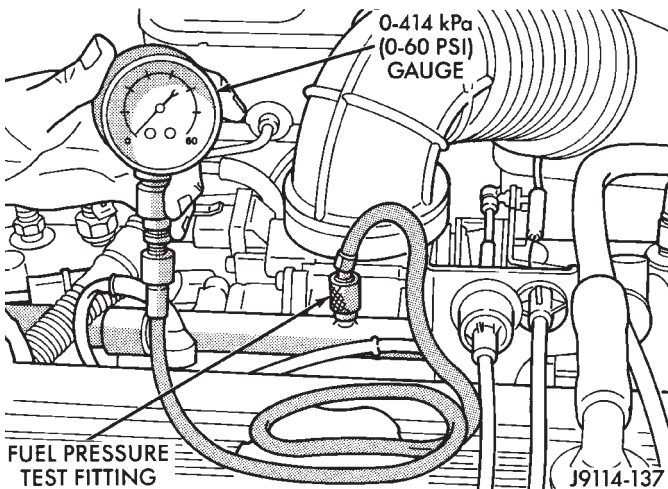

Fig. 9 Fuel Pressure Test Connection—Typical

(3) Disconnect vacuum line (hose) at fuel pressure regulator (Fig. 8). Note gauge reading. With vacuum line disconnected, fuel pressure should rise to approximately 269 kPa (39 psi).

Fuel pressure should be approximately 55-69 kPa (8-10 psi) higher with vacuum line removed from regulator. If not, inspect pressure regulator vacuum line for leaks, kinks or blockage. If vacuum line checks OK and fuel pressure does not rise approximately 8-10 psi after disconnecting vacuum line, replace fuel pressure regulator.

The fuel pressure regulator is **not adjustable**.

(4) If fuel pressure exceeds 45 psi, check fuel return line/tube for kinks or obstructions.

If the previous tests checked good, fuel pump pressure is correct. If pump pressure was low, proceed as follows:

(5) Release fuel system pressure. Refer to the previous Fuel Pressure Release Procedure in this group.

(6) Disconnect the 5/16 inch fuel return line quick-connect fitting at fuel rail. For procedures, refer to Fuel Tubes/Lines/Hoses and Clamps. Also refer to Quick-Connect Fittings. These can be found in the Fuel Delivery System section of this group.

Connect Fuel Line Pressure Test Adapter Tool number 6539 (5/16 in.) between the disconnected fuel return line and fuel rail (Fig. 10).

WARNING: THE FUEL SYSTEM PRESSURE IN THE FOLLOWING TEST MAY EXCEED 100 PSI. BEFORE STARTING TEST, VERIFY GOOD CONNECTIONS AT ENDS OF ADAPTER TOOL 6539. BE SURE TOOL IS LOCKED ONTO FUEL RAIL AND FUEL RETURN LINE. PULL FIRMLY ON ENDS OF TOOL TO VERIFY.

(7) To activate the fuel pump and pressurize the system, obtain the DRB scan tool. Refer to the appropriate Powertrain Diagnostic Procedures service manual for DRB operation.

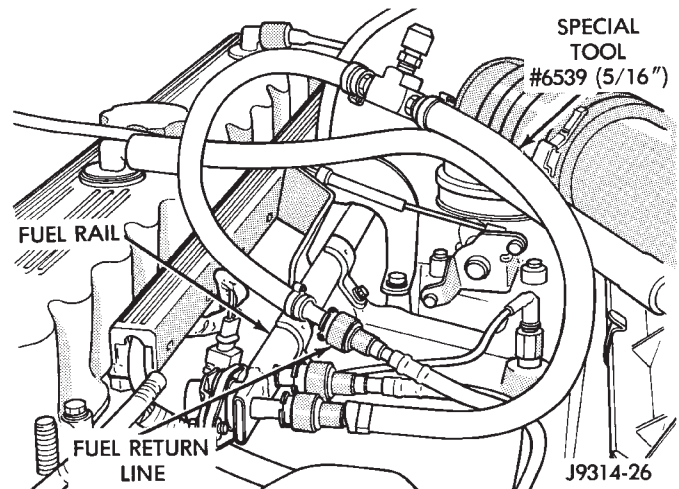

Fig. 10 Adapter Tool—Typical Connection

(8) **MOMENTARILY** pinch the rubber hose portion of adapter tool 6539. Pressure should rise to approximately 75 psi within two (2) seconds. **DO NOT** pinch hose for longer than three seconds.

If fuel pump pressure rises to approximately 75 psi within two seconds, pressure is operating at its maximum and is correct.

If fuel pump pressure does not rise to approximately 75 psi within two seconds, proceed as follows:

(9) Release fuel system pressure. Refer to the previous Fuel Pressure Release Procedure in this group.

(10) Raise and support vehicle.

(11) Disconnect fuel supply line at inlet (fuel tank side) of fuel filter. Connect Fuel Line Pressure Test Adapter Tool number 6631 (3/8 in.) between fuel filter and fuel supply line.

WARNING: THE FUEL SYSTEM PRESSURE IN THE FOLLOWING TEST MAY EXCEED 100 PSI. BEFORE STARTING TEST, VERIFY GOOD CONNECTIONS AT ENDS OF ADAPTER TOOL 6631. BE SURE TOOL IS LOCKED ONTO FUEL FILTER AND FUEL SUPPLY LINE. PULL FIRMLY ON ENDS OF TOOL TO VERIFY.

(12) To activate the fuel pump and pressurize the system, obtain the DRB scan tool. Refer to the appropriate Powertrain Diagnostic Procedures service manual for DRB operation.

MOMENTARILY pinch the rubber hose portion of adapter tool 6631. Pressure should rise to approximately 75 psi within two (2) seconds. **DO NOT** pinch hose for longer than three seconds.

If fuel pump pressure now rises to approximately 75 psi within two seconds, but this pressure could not be met at the fuel rail, check for a plugged or restricted fuel filter. Also check the fuel supply line between fuel filter and fuel rail for kinks or obstructions. Proceed to the following Fuel Pump Capacity Test.

FUEL PUMP CAPACITY TEST

Before performing this test, verify fuel pump pressure by performing the previous tests.

(1) Release the fuel system pressure from fuel system. Refer to the previous Fuel Pressure Release Procedure in this group.

(2) Disconnect the fuel supply line at fuel rail near pressure regulator. For procedures, refer to Fuel Tubes/Lines/Hoses and Clamps. Also refer to Quick-Connect Fittings. These can be found in the Fuel Delivery System section of this group.

(3) Connect Fuel Line Pressure Test Adapter Tool number 6631 (3/8 in.) into the disconnected fuel supply line. Insert the other end of tool 6631 into an approved gasoline container.

(4) To activate the fuel pump and pressurize the system, obtain the DRB scan tool. Refer to the appropriate Powertrain Diagnostic Procedures service manual for DRB operation.

A good fuel pump will deliver at least 1 liter of fuel per minute.

FUEL PRESSURE LEAK DOWN TEST

ENGINE OFF

Abnormally long periods of cranking to restart a hot engine that has been shut down for a short period of time may be caused by:

- Fuel pressure bleeding past the fuel pressure regulator.
- Fuel pressure bleeding past the check valve in the outlet end of the fuel tank mounted fuel pump.

(1) Remove protective cap at fuel rail test port (Fig. 11). With the engine off, connect an accurate 0-689 kPa (0-100 psi) fuel gauge to the pressure test port fitting on the fuel rail. The fitting on the pressure tester must be in good condition and free of any leaks before performing this test.

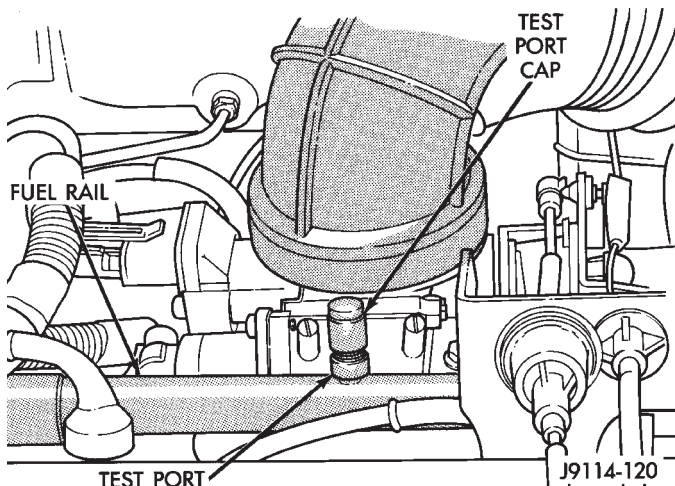

Fig. 11 Fuel Pressure Test Port—Typical

(2) Start the vehicle and let engine idle. Check fuel pressure reading on gauge. Fuel pressure should be within specifications. Refer to the previous Fuel System Pressure Tests.

(3) Shut engine off. Observe and record fuel pressure reading on gauge. Leave fuel pressure gauge connected. Allow engine to set for 30 minutes and then compare the fuel pressure reading on the gauge with the reading taken when engine was shut down. A pressure drop of up to 138 kPa (20 psi) within 30 minutes is within specifications.

(4) If the fuel pressure drop is within specifications, the fuel pump outlet check valve and fuel pressure regulator are both operating normally.

(5) If fuel pressure drop is greater than 138 kPa (20 psi), it must be determined if this drop is being caused by (in-tank mounted) fuel pump outlet check valve or fuel pressure regulator. Proceed to next step.

(6) Release the fuel system pressure from fuel system. Refer to the previous Fuel Pressure Release Procedure in this group.

(7) Disconnect both fuel lines at fuel rail near fuel pressure regulator. For procedures, refer to Fuel Tubes/Lines/Hoses and Clamps. Also refer to Quick-Connect Fittings. These can be found in the Fuel Delivery System section of this group.

(8) Connect Fuel Line Pressure Test Adapter Tool number 6631 (3/8 in.) between the disconnected fuel supply line and fuel rail (Fig. 12).

(9) Connect Fuel Line Pressure Test Adapter Tool number 6539 (5/16 in.) between the disconnected fuel return line and fuel rail (Fig. 12).

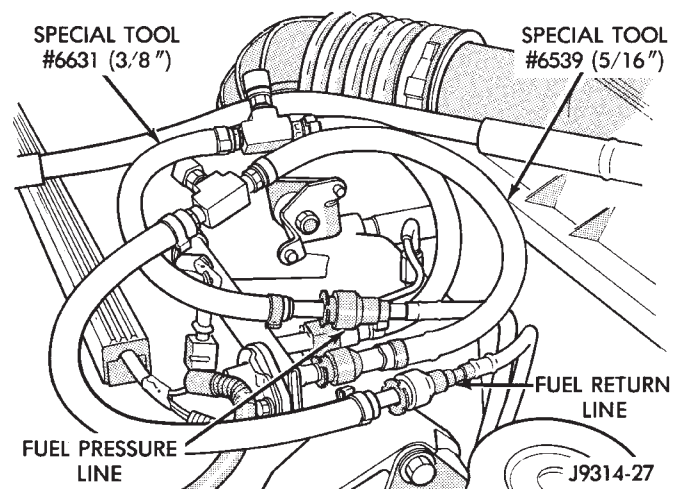

Fig. 12 Adapter Tools—Typical Connections

(10) Start engine. Observe and record fuel system pressure.

(11) Shut engine off.

(12) Clamp off the rubber hose portion of adapter tool number 6539 connected to the fuel return line. Allow engine to set for 30 minutes. If pressure has dropped more than 138 kPa (20 psi) in 30 minutes,

pressure is bleeding past the (in-tank mounted) fuel pump outlet check valve. Replace Fuel Pump Module assembly. Refer to Fuel Pump Module removal and installation in this group. If pressure drop is within specifications, proceed to next step.

(13) Clamp off the rubber hose portion of adapter tool number 6631 connected to the fuel supply line. Allow engine to set for 30 minutes. If pressure has dropped more than 138 kPa (20 psi) in 30 minutes, pressure is bleeding past the fuel pressure regulator. Replace fuel pressure regulator. Refer to Fuel Rail removal and installation in the Component Removal/Installation section of this group.

MECHANICAL MALFUNCTIONS

Mechanical malfunctions are more difficult to diagnose with this system. The powertrain control module (PCM) has been programmed to compensate for some mechanical malfunctions such as incorrect cam timing, vacuum leaks, etc. If engine performance problems are encountered and diagnostic trouble codes are not displayed, the problem may be mechanical rather than electronic.

FUEL FILTER

The fuel filter protects the fuel injectors and fuel pressure regulator from dirt, water and other foreign matter. The filter is located under the vehicle along the frame rail (Figs. 13 or 14). Replace fuel filter at intervals specified in the Lubrication and Maintenance Schedule chart found in Group 0, Lubrication and Maintenance.

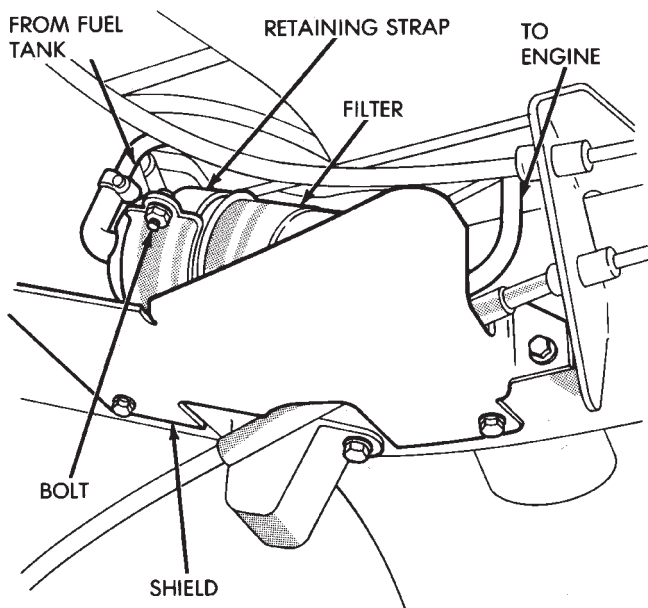

J8914-4

Fig. 13 Fuel Filter and Shield—YJ Models

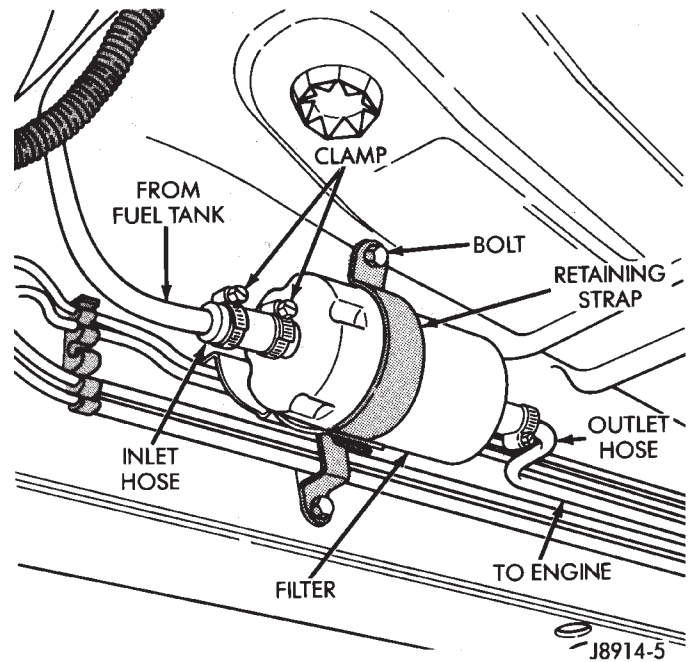

Fig. 14 Fuel Filter—XJ Models

REMOVAL

WARNING: THE FUEL SYSTEM IS UNDER CONSTANT FUEL PRESSURE (EVEN WITH THE ENGINE OFF) OF APPROXIMATELY 131-269 KPA (19-39 PSI). THIS PRESSURE MUST BE RELEASED BEFORE SERVICING THE FUEL FILTER.

(1) Disconnect negative battery cable. Remove fuel filler cap.

WARNING: FUEL PRESSURE MUST BE RELEASED BEFORE DISCONNECTING ANY FUEL SYSTEM COMPONENT.

(2) Release fuel system pressure. Refer to Fuel Pressure Release Procedure in this group.

(3) Raise and support vehicle.

(4) On YJ models remove the fuel filter shield (Fig. 13).

(5) Remove hoses and clamps from inlet and outlet sides of filter (Figs. 13 or 14). For procedures, refer to Fuel Tubes/Lines/Hoses and Clamps. Also refer to Quick-Connect Fittings. These can be found in the Fuel Delivery System section of this group.

(6) Remove retaining strap bolt.

(7) Remove filter from vehicle.

INSTALLATION

CAUTION: The ends of the fuel filter are marked for correct installation. Install filter with the end marked IN towards fuel tank and the end marked OUT towards engine.

(1) Place fuel filter in retaining strap with the marked ends in the correct position.

(2) Install retaining strap bolt and tighten to 12 N·m (106 in. lbs.) torque.

(3) Install inlet and outlet hoses and hose clamps. For procedures, refer to Fuel Tubes/Lines/Hoses and Clamps. Also refer to Quick-Connect Fittings. These can be found in the Fuel Delivery System section of this group.

(4) On YJ models, install fuel filter shield (Fig. 13).

(5) Lower vehicle.

(6) Connect negative battery cable.

(7) Start engine and check for leaks.

FUEL TUBES/LINES/HOSES AND CLAMPS

Also refer to the proceeding section on Quick-Connect Fittings.

WARNING: THE FUEL SYSTEM IS UNDER A CONSTANT PRESSURE (EVEN WITH THE ENGINE OFF). BEFORE SERVICING ANY FUEL SYSTEM HOSES, FITTINGS OR LINES, THE FUEL SYSTEM PRESSURE MUST BE RELEASED. REFER TO THE FUEL PRESSURE RELEASE PROCEDURE IN THIS GROUP.

Inspect all hose connections such as clamps, couplings and fittings to make sure they are secure and leaks are not present. The component should be replaced immediately if there is any evidence of degradation that could result in failure.

Never attempt to repair a plastic fuel line/tube. Replace as necessary.

Avoid contact of any fuel tubes/hoses with other vehicle components that could cause abrasions or scuffing. Be sure that the plastic fuel lines/tubes are properly routed to prevent pinching and to avoid heat sources.

The lines/tubes/hoses used on fuel injected vehicles are of a special construction. This is due to the higher fuel pressures and the possibility of contaminated fuel in this system. If it is necessary to replace these lines/tubes/hoses, only those marked EFM/EFI may be used.

The hose clamps used to secure rubber hoses on fuel injected vehicles are of a special rolled edge construction. This construction is used to prevent the edge of the clamp from cutting into the hose. Only these rolled edge type clamps may be used in this system. All other types of clamps may cut into the hoses and cause high pressure fuel leaks.

Use new original equipment type hose clamps. Tighten hose clamps to 1 N·m (15 in. lbs.) torque.

QUICK-CONNECT FITTINGS

Also refer to the previous Fuel Tubes/Lines/Hoses and Clamps section.

Different types of quick-connect fittings are used to attach various fuel system components. These are: a single-tab type, a two-tab type or a plastic retainer ring type.

SINGLE-TAB TYPE

This type of fitting is equipped with a single pull tab (Fig. 15). The tab is removable. After the tab is removed, the quick-connect fitting can be separated from the fuel system component.

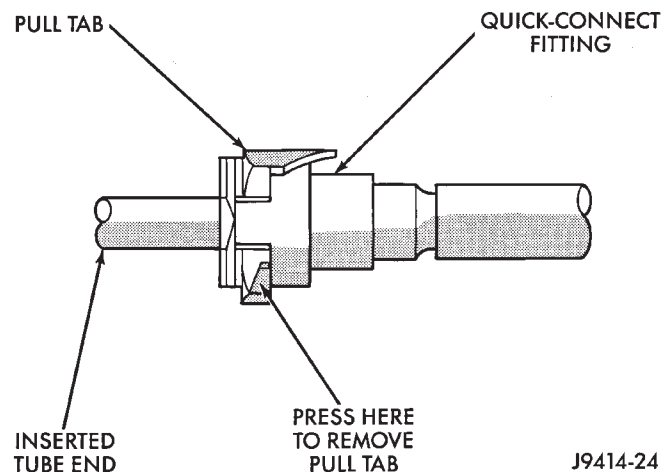

Fig. 15 Single-Tab Type Fitting

CAUTION: The interior components (O-rings, spacers) of this type of quick-connect fitting are not serviced separately, but new pull tabs are available. Do not attempt to repair damaged fittings or fuel lines/tubes. If repair is necessary, replace the complete fuel tube/quick-connect fitting assembly.

WARNING: THE FUEL SYSTEM IS UNDER A CONSTANT PRESSURE (EVEN WITH THE ENGINE OFF). BEFORE SERVICING ANY FUEL SYSTEM HOSES, FITTINGS OR LINES, THE FUEL SYSTEM PRESSURE MUST BE RELEASED. REFER TO THE FUEL PRESSURE RELEASE PROCEDURE IN THIS GROUP.

DISCONNECTION/CONNECTION

(1) Disconnect negative battery cable from battery.
 (2) Perform the fuel pressure release procedure. Refer to the Fuel Pressure Release Procedure in this section.

(3) Clean the fitting of any foreign material before disassembly.

(4) Press the release tab on the side of fitting to release pull tab (Fig. 15).

CAUTION: If this release tab is not pressed prior to releasing the pull tab, the pull tab will be damaged.

(5) While pressing the release tab on the side of the fitting, use a screwdriver to pry up the pull tab (Fig. 16).

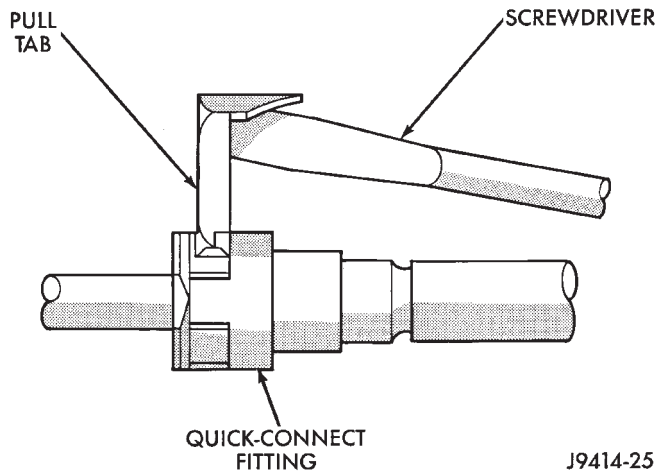

Fig. 16 Disconnecting Single-Tab Type Fitting

(6) Raise the pull tab until it separates from the quick-connect fitting (Fig. 17). Discard the old pull tab.

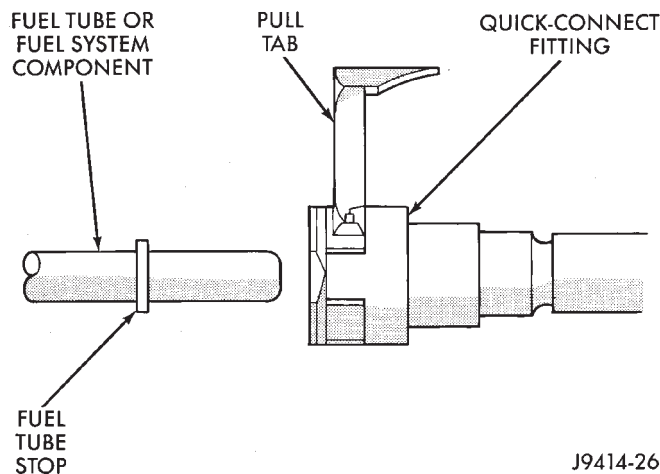

Fig. 17 Removing Pull Tab

(7) Disconnect the quick-connect fitting from the fuel system component being serviced.

(8) Inspect the quick-connect fitting body and fuel system component for damage. Replace as necessary.

(9) Prior to connecting the quick-connect fitting to component being serviced, check condition of fitting and component. Clean the parts with a lint-free cloth. Lubricate them with clean engine oil.

(10) Insert the quick-connect fitting into the fuel tube or fuel system component until the built-on stop on the fuel tube or component rests against back of fitting.

(11) Obtain a new pull tab. Push the new tab down until it locks into place in the quick-connect fitting.

(12) Verify a locked condition by firmly pulling on fuel tube and fitting (15-30 lbs.).

(13) Connect negative cable to battery.

(14) Start engine and check for leaks.

TWO-TAB TYPE FITTING

This type of fitting is equipped with tabs located on both sides of the fitting (Fig. 18). These tabs are supplied for disconnecting the quick-connect fitting from component being serviced.

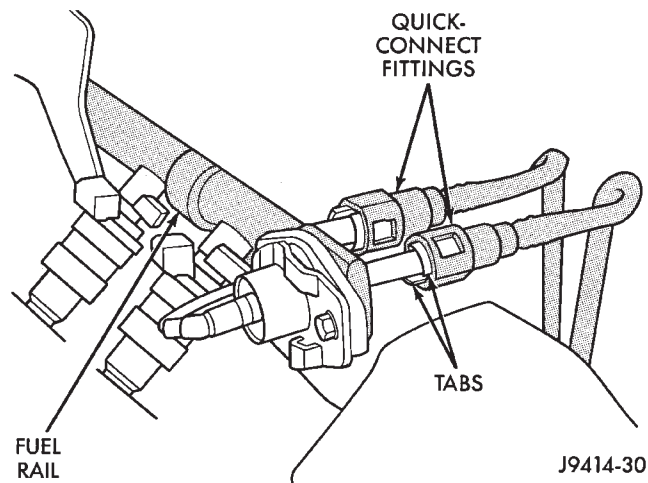

Fig. 18 Typical Two-Tab Type Quick-Connect Fitting

CAUTION: The interior components (O-rings, spacers) of this type of quick-connect fitting are not serviced separately, but new plastic retainers are available. Do not attempt to repair damaged fittings or fuel lines/tubes. If repair is necessary, replace the complete fuel tube/quick-connect fitting assembly.

WARNING: THE FUEL SYSTEM IS UNDER A CONSTANT PRESSURE (EVEN WITH THE ENGINE OFF). BEFORE SERVICING ANY FUEL SYSTEM HOSES, FITTINGS OR LINES, THE FUEL SYSTEM PRESSURE MUST BE RELEASED. REFER TO THE FUEL PRESSURE RELEASE PROCEDURE IN THIS GROUP.

DISCONNECTION/CONNECTION

(1) Disconnect negative battery cable from the battery.

(2) Perform the fuel pressure release procedure. Refer to the Fuel Pressure Release Procedure in this section.

(3) Clean the fitting of any foreign material before disassembly.

(4) To disconnect the quick-connect fitting, squeeze the plastic retainer tabs against the sides of the quick-connect fitting with your fingers. Tool use is not required for removal and may damage plastic re-

tainer. Pull the fitting from the fuel system component being serviced. The plastic retainer will remain on the component being serviced after fitting is disconnected. The O-rings and spacer will remain in the quick-connect fitting connector body.

(5) Inspect the quick-connect fitting body and component for damage. Replace as necessary.

CAUTION: When the quick-connect fitting was disconnected, the plastic retainer will remain on the component being serviced. If this retainer must be removed, very carefully release the retainer from the component with two small screwdrivers. After removal, inspect the retainer for cracks or any damage.

(6) Prior to connecting the quick-connect fitting to component being serviced, check condition of fitting and component. Clean the parts with a lint-free cloth. Lubricate them with clean engine oil.

(7) Insert the quick-connect fitting to the component being serviced and into the plastic retainer. When a connection is made, a click will be heard.

(8) Verify a locked condition by firmly pulling on fuel tube and fitting (15-30 lbs.).

(9) Connect negative cable to battery.

(10) Start engine and check for leaks.

PLASTIC RETAINER RING TYPE FITTING

This type of fitting can be identified by the use of a full-round plastic retainer ring (Fig. 19) usually black in color.

CAUTION: The interior components (O-rings, spacers, retainers) of this type of quick-connect fitting are not serviced separately. Do not attempt to repair damaged fittings or fuel lines/tubes. If repair is necessary, replace the complete fuel tube/quick-connect fitting assembly.

WARNING: THE FUEL SYSTEM IS UNDER A CONSTANT PRESSURE (EVEN WITH THE ENGINE OFF). BEFORE SERVICING ANY FUEL SYSTEM HOSES, FITTINGS OR LINES, THE FUEL SYSTEM PRESSURE MUST BE RELEASED. REFER TO THE FUEL PRESSURE RELEASE PROCEDURE IN THIS GROUP.

DISCONNECTION/CONNECTION

(1) Disconnect negative battery cable from the battery.

(2) Perform the fuel pressure release procedure.

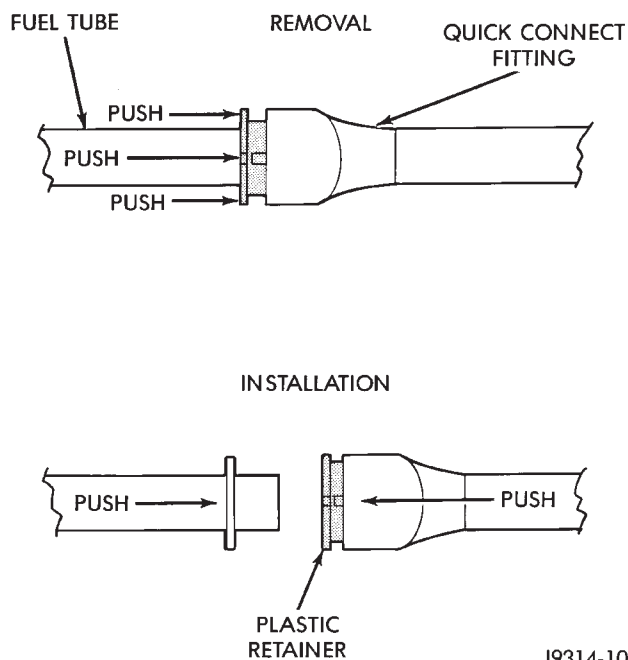

Fig. 19 Plastic Retainer Ring Type Fitting

Refer to the Fuel Pressure Release Procedure in this section.

(3) Clean the fitting of any foreign material before disassembly.

(4) To release the fuel system component from the quick-connect fitting, firmly push the fitting towards the component being serviced while firmly pushing the plastic retainer ring into the fitting (Fig. 19). With the plastic ring depressed, pull the fitting from the component. **The plastic retainer ring must be pressed squarely into the fitting body. If this retainer is cocked during removal, it may be difficult to disconnect fitting. Use an open-end wrench on the shoulder of the plastic retainer ring to aid in disconnection.**

After disconnection, the plastic retainer ring will remain with the quick-connect fitting connector body.

(5) Inspect fitting connector body, plastic retainer ring and fuel system component for damage. Replace as necessary.

(6) Prior to connecting the quick-connect fitting to component being serviced, check condition of fitting and component. Clean the parts with a lint-free cloth. Lubricate them with clean engine oil.

(7) Insert the quick-connect fitting into the component being serviced until a click is felt.

(8) Verify a locked condition by firmly pulling on fuel tube and fitting (15-30 lbs.).

(9) Connect negative battery cable to battery.

(10) Start engine and check for leaks.

FUEL TANKS

INDEX

	page		page
Fuel Gauge Sending Unit	15	General Information	12
Fuel Tank	12	Heat Shields	12
Fuel Tank Filler Tube Cap	12	No-Lead Fuel Tank Filler Tube	12
Fuel Tank Pressure Relief/Rollover Valve	15		

GENERAL INFORMATION

All vehicles pass a full 360 degree rollover test without fuel leakage. To accomplish this, fuel and vapor flow controls are required for all fuel tank connections.

All models are equipped with a pressure relief/rollover valve mounted in the top of the fuel pump module. The return line from the fuel pump to the fuel tank contains a one-way check valve.

An evaporative control system prevents raw fuel vapor from escaping into the atmosphere. Fuel vapors from the fuel tank are collected in the EVAP canister. When the engine is operating, the vapors are drawn into the intake manifold to be used in combustion. Refer to Group 25, Emission Control System for more information.

Inspect all hose/tube connections for completeness. Be sure that leaks are not present. Replace any hose that is cracked, scuffed, swelled, has rubbed against other vehicle components or shows any other sign of wear that could lead to failure. If it is necessary to replace a hose, only hose marked EFM/EFI may be used.

When installing hoses, be sure that they are routed away from contact with other vehicle components.

The hose clamps used on fuel injected vehicles are of a special rolled edge construction to prevent the edge of the clamp from cutting into the hose. Only these rolled edge type clamps may be used on this system. Other types of clamps may cut into the hoses and cause high pressure fuel leaks.

FUEL TANK CAPACITIES

FUEL TANK	GALLONS*	LITERS*
XJ	20.02	76
YJ	20.0	76
YJ	15.0	57

*Nominal refill capacities are shown. A variation may be observed from vehicle to vehicle due to manufacturing tolerances, ambient temperature and refill procedure.

J9314-143

NO-LEAD FUEL TANK FILLER TUBE

All vehicles are designed to operate using Unleaded fuels. The diameter of the opening in the fuel tank filler neck is sized to only accept unleaded fuel nozzles. Gasoline station pumps for unleaded and leaded fuels have different size nozzles. Leaded fuel nozzles are larger in diameter than unleaded nozzles. The fuel tank filler neck opening is also equipped with a deflector, which the smaller unleaded nozzle pushes back upon entering the filler neck. The deflector will prevent the larger diameter leaded fuel nozzles from entering the filler neck and will deflect fuel away from the filler neck. This happens if filling of the tank with leaded fuel is attempted.

A label is attached to the instrument panel under the fuel gauge that reads UNLEADED FUEL ONLY as a reminder to the driver. A similar label is located near the fuel tank filler.

FUEL TANK FILLER TUBE CAP

The loss of any fuel or vapor out of the filler neck is prevented by the use of a safety filler cap. This will release only under pressure of 10.9 to 13.45 kPa (1.58 to 1.95 psi). The vacuum release is between .97 and 2.0 kPa (.14 and .29 psi). This cap must be replaced by a similar unit if replacement is necessary.

CAUTION: Remove the fuel tank filler tube cap prior to removing or repairing fuel lines to relieve fuel tank pressure.

HEAT SHIELDS

The sheet metal heat shields may have to be removed when servicing the fuel tank, fuel lines or vapor vent line. The heat shields must be installed to protect the lines and tank from the heat of the exhaust system. Refer to Group 11, Exhaust System and Intake Manifold for proper installation.

FUEL TANK

WARNING: THE FUEL SYSTEM IS UNDER CONSTANT FUEL PRESSURE (EVEN WITH THE ENGINE OFF) OF APPROXIMATELY 131-269 KPA (19-39 PSI). THIS PRESSURE MUST BE RELEASED BEFORE SERVICING FUEL TANK.

REMOVAL—XJ MODELS

Perform the preceding Fuel System Pressure Release Procedure.

- (1) Disconnect negative battery cable.
- (2) Remove the fuel filler cap. Using an approved portable gasoline siphon/storage tank, drain fuel tank.
- (3) Raise and support vehicle.
- (4) Disconnect fuel fill hose and fill vent hose from filler neck (Fig. 1).

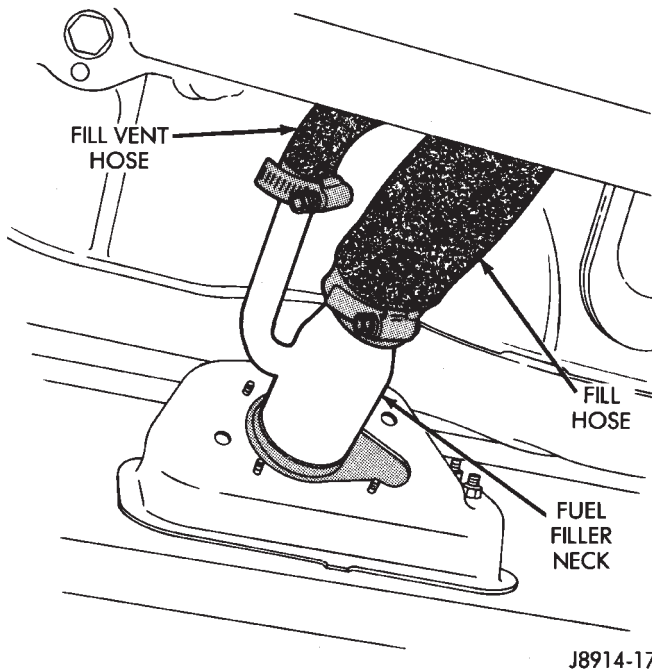

Fig. 1 Filler Neck Hoses—XJ Models

- (5) Disconnect fuel pump module wire connector. Remove tie straps securing connector harness to fuel supply and return tubes.

WARNING: WRAP SHOP TOWELS AROUND FUEL HOSES TO ABSORB ANY FUEL SPILLAGE DURING FUEL TANK REMOVAL.

- (6) Disconnect fuel tank vent hose from vent tube.
- (7) Disconnect fuel supply and return hoses from tubes.
- (8) If equipped, remove skid plate (Fig. 2).
- (9) Remove fuel tank shield (Fig. 3).
- (10) Center a transmission jack under the fuel tank.
- (11) Remove support strap nuts. Move straps away from tank (Fig. 3).
- (12) Lower fuel tank on transmission jack.

INSTALLATION—XJ MODELS

- (1) Raise fuel tank into position. Connect fuel fill hose and vent hose to filler neck and tighten clamps.
- (2) Wrap support straps around tank and over studs. Tighten strap nuts to 11.3 N·m (100 in. lbs.) torque.
- (3) Remove transmission jack.

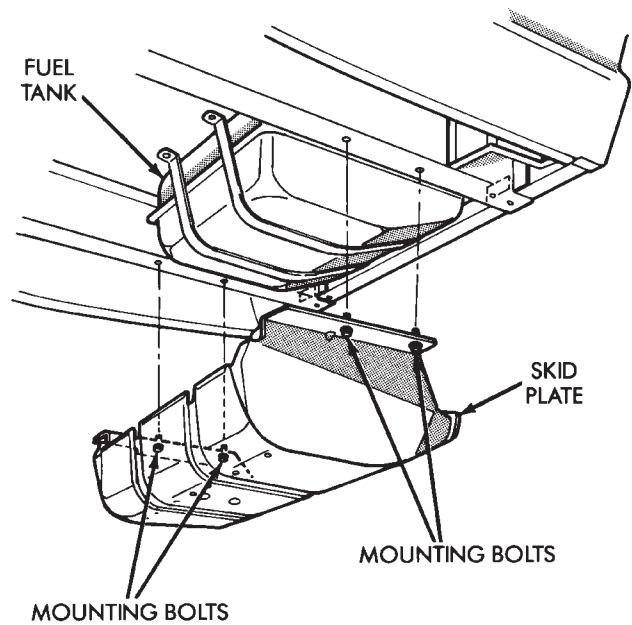

Fig. 2 Skid Plate—XJ Models

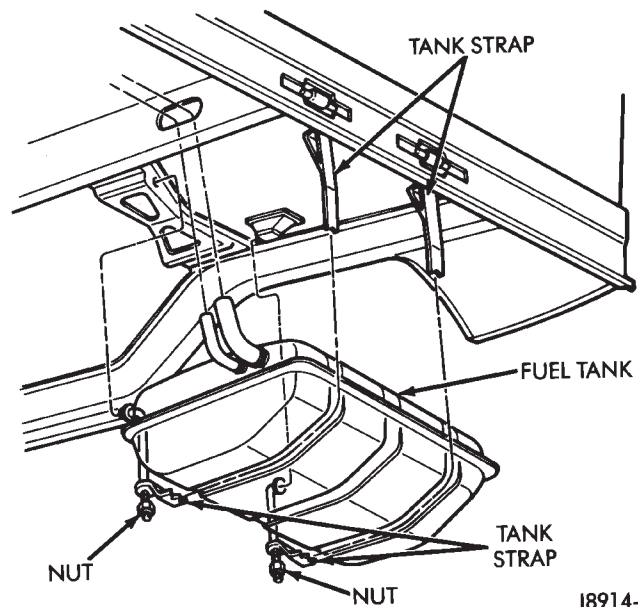

Fig. 3 Fuel Tank Remove/Install—XJ Models

- (4) Install tank shield.
- (5) If equipped, install tank skid plate.
- (6) Connect vent hose to vent tube.
- (7) Connect fuel supply hose to supply tube and fuel return hose to return tube. Tighten hose clamps.
- (8) Connect fuel pump module wire connector to harness connector. Secure fuel pump module wire harness to fuel tubes with tie straps.
- (9) Lower vehicle.
- (10) Fill fuel tank. Install filler cap.
- (11) Connect negative battery cable to battery.
- (12) Start vehicle and inspect for leaks.

REMOVAL—YJ MODELS

WARNING: EXTINGUISH ALL TOBACCO SMOKING PRODUCTS BEFORE SERVICING THE FUEL SYSTEM. KEEP OPEN FLAME AWAY FROM FUEL SYSTEM COMPONENTS.

- (1) Disconnect negative battery cable.
- (2) Remove the fuel filler cap. Using an approved portable gasoline siphon/storage tank, drain fuel tank.
- (3) Raise and support vehicle.
- (4) Using a small straight blade screwdriver, pull back the stems of the push clips that secure the fuel filler neck shroud (located at bottom of left rear wheel well) in place (Fig. 4). This unlocks the push clip allowing them to be removed by pulling assembly out of shroud. Remove shroud.

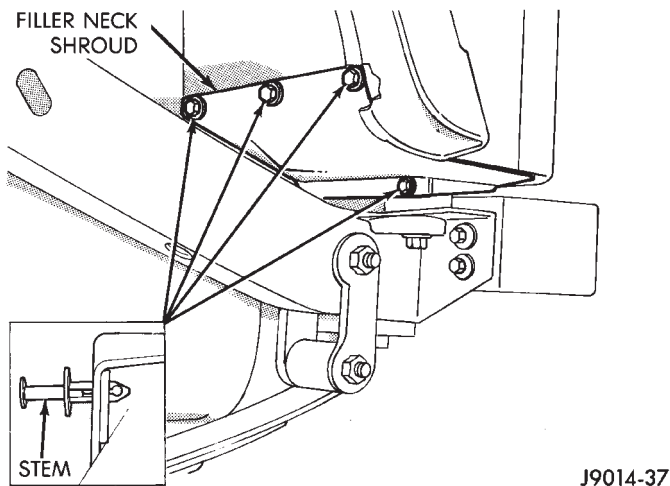

Fig. 4 Fuel Filler Neck Shroud—YJ Models

- (5) Disconnect fuel fill hose and fill vent hose from filler neck (Fig. 5).

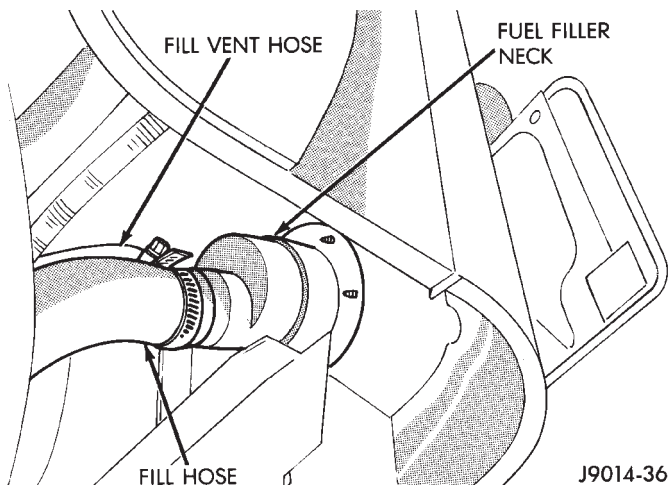

Fig. 5 Filler Neck Hoses—YJ Models

WARNING: WRAP SHOP TOWELS AROUND FUEL HOSES TO ABSORB ANY FUEL SPILLAGE DURING FUEL TANK REMOVAL.

- (6) Disconnect fuel tank vent hose from vent tube. Disconnect fuel supply and return hoses from tubes (Fig. 6).

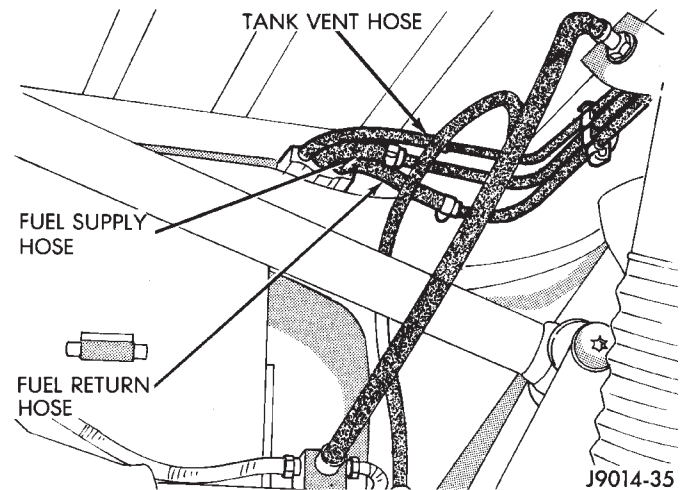

Fig. 6 Fuel Tank Hoses—YJ Models

The fuel tank and skid plate are removed as an assembly.

- (7) Centrally position a transmission jack under skid plate/fuel tank assembly.
- (8) Remove skid plate/fuel tank assembly mounting nuts (Fig. 7). **Do not loosen tank strap nuts.**

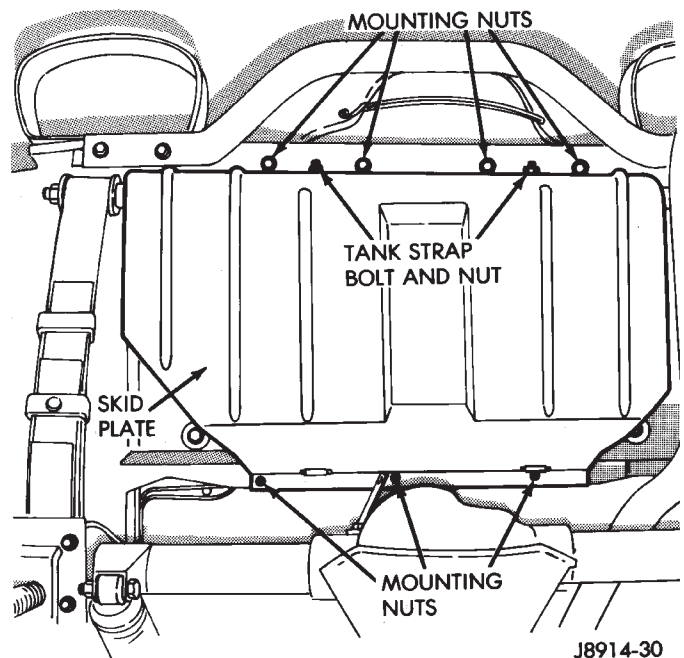

Fig. 7 Fuel Tank—Remove/Install—YJ Models

- (9) Lower the skid plate/fuel tank assembly slightly and disconnect the gauge sender wire connector.
- (10) Lower the fuel tank on transmission jack.
- (11) Remove tank strap nuts to remove tank from skid plate.

INSTALLATION—YJ MODELS

- (1) Place tank into skid plate. Wrap straps around tank with strap bolts inserted through holes in skid plate. Tighten strap nuts to 7.3 N·m (65 in. lbs.) torque.
- (2) Raise skid plate/fuel tank until gauge sender wire connector can be connected to harness connector.
- (3) Finish raising skid plate/fuel tank assembly into position. Tighten mounting nuts to 16 N·m (12 ft. lbs.) torque. Remove transmission jack.
- (4) Connect fuel fill hose and fill vent hose to filler neck. Tighten hose clamps.
- (5) Connect vent hose to vent tube.
- (6) Connect fuel supply hose to the supply tube and fuel return hose to return tube. Tighten hose clamps.
- (7) Install fuel filler neck shroud with push clips.
- (8) Lower vehicle.
- (9) Fill fuel tank. Install filler cap.
- (10) Connect negative battery cable to battery.
- (11) Start vehicle and inspect for leaks.

FUEL GAUGE SENDING UNIT

The fuel gauge sending unit is attached to the fuel pump module. Refer to Fuel Pump Module in the Fuel Delivery System section of this group.

FUEL TANK PRESSURE RELIEF/ROLLOVER VALVE

The fuel tank is equipped with a pressure relief/rollover valve (Fig. 8). The dual function valve will relieve fuel tank pressure and prevent fuel flow through the fuel tank vent tubes in the event of accidental vehicle rollover.

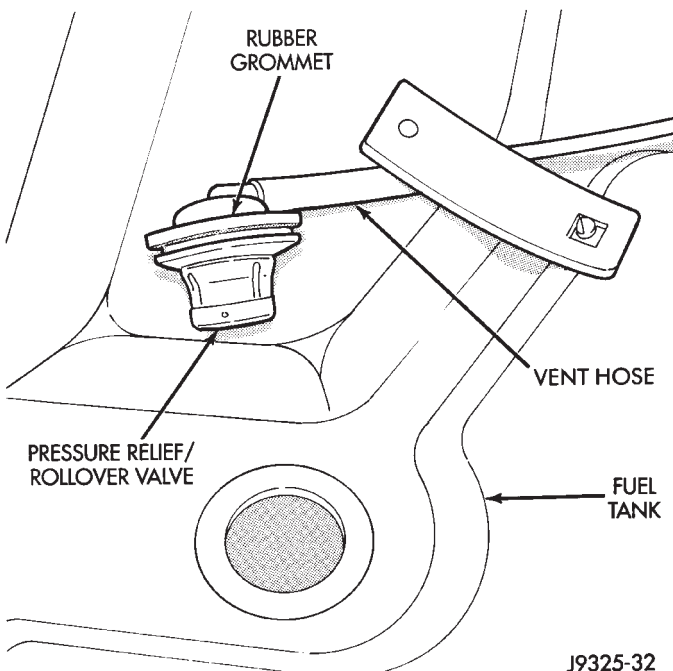
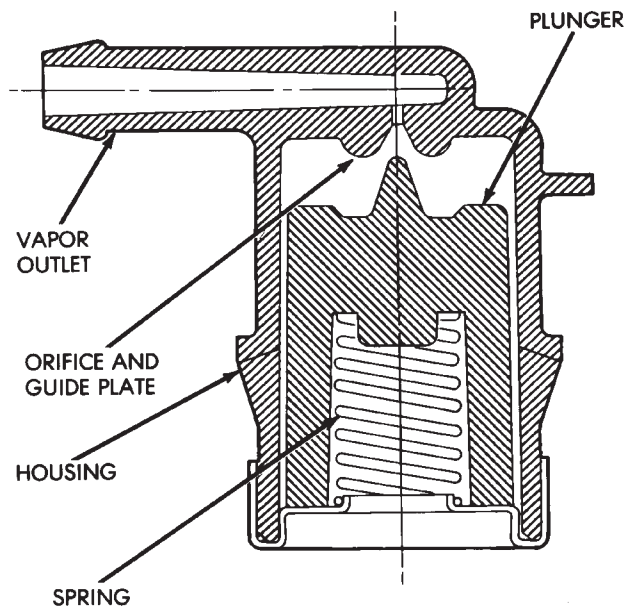

Fig. 8 Valve Location—Typical

The valve consists of a plunger, spring and orifice/guide plate (Fig. 9). The valve is normally open allowing fuel vapor to vent to the EVAP canister. Here it is stored until it can be consumed by the engine (under

controlled conditions). The plunger seats in the guide plate at the orifice preventing liquid fuel from reaching the EVAP canister. This is done if bottom of plunger is contacted by fuel sloshing in tank when vehicle is cornering.

In the event of accidental vehicle rollover, the valve is inverted. In this position the plunger is forced against the guide plate and raw fuel is prevented from flowing through the valve orifice into the fuel tank vent tube.



J8914-33

Fig. 9 Pressure Relief/Rollover Valve Operation

REMOVAL

WARNING: THE FUEL SYSTEM IS UNDER A CONSTANT PRESSURE (EVEN WITH THE ENGINE OFF). BEFORE SERVICING THE PRESSURE RELIEF/ROLLOVER VALVE, THE FUEL SYSTEM PRESSURE MUST BE RELEASED. REFER TO THE FUEL PRESSURE RELEASE PROCEDURE IN THIS GROUP.

- (1) Disconnect negative battery cable.
- (2) Remove the fuel filler cap and drain fuel tank. Refer to Fuel Tank Removal.
- (3) Remove fuel tank. Refer to Fuel Tank Removal.
- (4) The rollover valve is seated in a grommet. Remove by prying one side upward and then roll the grommet out of tank (Fig. 8).

INSTALLATION

- (1) Start one side of grommet into opening in fuel tank. Using finger pressure only, press valve/grommet into place.
- (2) Install fuel tank. Refer to Fuel Tank Installation.
- (3) Fill fuel tank. Install fuel tank filler cap.
- (4) Connect negative battery cable.
- (5) Start vehicle and check for leaks.

ACCELERATOR PEDAL AND THROTTLE CABLE

GENERAL INFORMATION

The accelerator pedal is connected to the throttle body linkage by the throttle cable. The cable is protected by a plastic sheathing and is connected to the throttle body linkage by a ball socket. It is connected to the upper part of the accelerator pedal arm by a plastic retainer (clip) (Fig. 10). This retainer (clip) snaps into the top of the accelerator pedal arm. Retainer tabs (built into the cable sheathing) (Fig. 10) fasten the cable to the dash panel.

Dual throttle return springs (attached to the throttle shaft) are used to close the throttle.

CAUTION: Never attempt to remove or alter these springs.

ACCELERATOR PEDAL

CAUTION: Be careful not to damage or kink the cable core wire (within the cable sheathing) while servicing the accelerator pedal or throttle cable.

REMOVAL

(1) From inside the vehicle, hold up accelerator pedal. Remove plastic cable retainer (clip) and throttle cable core wire from upper end of accelerator pedal arm (Fig. 10). Plastic cable retainer (clip) snaps into pedal arm.

(2) Remove accelerator pedal mounting bracket nuts. Remove accelerator pedal assembly.

INSTALLATION

(1) Place accelerator pedal assembly over studs protruding from floor pan. Tighten mounting nuts to 5 N·m (36 in. lbs.) torque.

(2) Slide throttle cable into opening in top of pedal

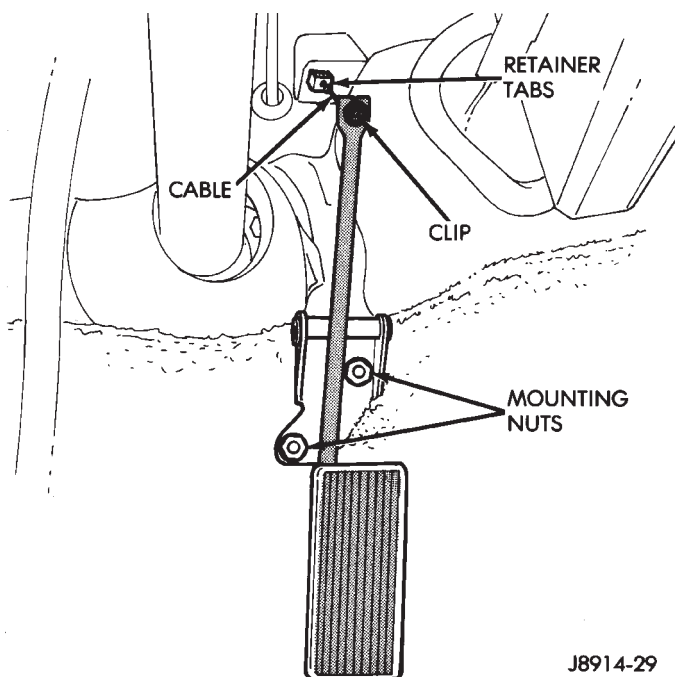

Fig. 10 Accelerator Pedal Mounting—Typical

arm. Push plastic cable retainer (clip) into accelerator pedal arm opening until it snaps into place.

(3) Before starting engine, operate accelerator pedal to check for any binding.

THROTTLE CABLE

REMOVAL

(1) From inside the vehicle, hold up accelerator pedal. Remove plastic cable retainer (clip) and throttle cable core wire from upper end of accelerator pedal arm (Fig. 10). Plastic cable retainer (clip) snaps into pedal arm.

(2) Remove the cable core wire at pedal arm.

(3) From inside the vehicle, pinch both sides of the cable housing retainer tabs (Fig. 10) at the dash panel. Remove cable housing from dash panel and pull into the engine compartment.

(4) Remove cable from clip on the engine cylinder head (valve) cover.

(5) Remove the throttle cable ball end socket at throttle body linkage (snaps off) (Fig. 11).

(6) Remove throttle cable from throttle body mounting bracket by compressing retainer tabs and pushing cable through hole in bracket. Remove throttle cable from vehicle.

INSTALLATION

(1) Slide throttle cable through hole in throttle body bracket until retainer tabs lock into bracket. Connect cable ball end to throttle body linkage ball (snaps on).

(2) Snap cable into clip on the engine cylinder head (valve) cover.

(3) Push other end of cable through opening in dash panel until retaining tabs lock into panel.

(4) From inside drivers compartment, slide throttle cable core wire into opening in top of accelerator pedal arm. Push cable retainer (clip) into pedal arm opening until it snaps in place.

(5) Before starting engine, operate accelerator pedal to check for any binding.

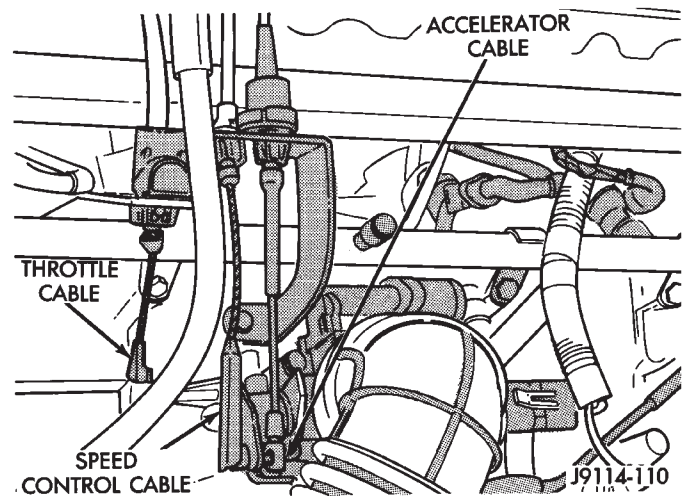

Fig. 11 Throttle (Accelerator) Cable—Typical

MULTI-PORT FUEL INJECTION (MFI)—COMPONENT DESCRIPTION/SYSTEM OPERATION

INDEX

	page		page
Air Conditioning (A/C) Clutch Relay—PCM Output	24	Intake Air Temperature Sensor—PCM Input	20
Air Conditioning (A/C) Controls—PCM Input	19	Malfunction Indicator Lamp—PCM Output	26
Auto Shut Down (ASD) Relay—PCM Output	24	Manifold Absolute Pressure (MAP) Sensor—PCM Input	21
Automatic Shut Down (ASD) Sense—PCM Input	19	Open Loop/Closed Loop Modes of Operation	27
Battery Voltage—PCM Input	19	Overdrive/Override Switch	22
Brake Switch—PCM Input	20	Oxygen (O ₂ S) Sensor—PCM Input	22
Camshaft Position Sensor—PCM Input	20	Park/Neutral Switch—PCM Input	22
Crankshaft Position Sensor—PCM Input	20	Power Ground	22
Data Link Connector—PCM Input	20	Power Steering Pressure Switch—PCM Input	22
Data Link Connector—PCM Output	24	Powertrain Control Module (PCM)	18
EMR Lamp—PCM Output	24	Radiator Fan Relay—PCM Output	26
Engine Coolant Temperature Sensor—PCM Input	21	SCI Receive—PCM Input	22
Extended Idle Switch—PCM Input	21	SCI Transmit—PCM Output	26
Fuel Injectors—PCM Output	25	Sensor Return—PCM Input	23
Fuel Pressure Regulator	30	Shift Indicator—PCM Output	26
Fuel Pump Relay—PCM Output	25	Speed Control—PCM Input	23
Fuel Rail	30	Speed Control—PCM Output	27
General Information	17	Tachometer—PCM Output	27
Generator Field—PCM Output	25	Throttle Body	29
Generator Lamp—PCM Output	25	Throttle Position Sensor (TPS)—PCM Input	23
Idle Air Control (IAC) Motor—PCM Output	25	Torque Converter Clutch Relay—PCM Output	27
Ignition Circuit Sense—PCM Input	21	Vehicle Speed Sensor—PCM Input	23
Ignition Coil—PCM Output	26		

GENERAL INFORMATION

All 2.5L 4 cylinder and 4.0L 6 cylinder engines are equipped with sequential Multi-Port Fuel Injection (MFI). The MFI system provides precise air/fuel ratios for all driving conditions.

The Powertrain Control Module (PCM) operates the fuel system. The PCM was formerly referred to as the SBEC or engine controller. The PCM is a pre-programmed, dual microprocessor digital computer. It regulates ignition timing, air-fuel ratio, emission control devices, charging system, speed control, air conditioning compressor clutch engagement and idle speed. The PCM can adapt its programming to meet changing operating conditions.

Powertrain Control Module (PCM) Inputs represent the instantaneous engine operating conditions. Air-fuel mixture and ignition timing calibrations for various driving and atmospheric conditions are pre-programmed into the PCM. The PCM monitors and analyzes various inputs. It then computes engine fuel and ignition timing requirements based on these inputs. Fuel delivery control and ignition timing will then be adjusted accordingly.

Other inputs to the PCM are provided by the brake light switch, air conditioning select switch and the speed control switches. All inputs to the PCM are converted into signals.

Electrically operated fuel injectors spray fuel in precise metered amounts into the intake port directly

above the intake valve. The injectors are fired in a specific sequence by the PCM. The PCM maintains an air/fuel ratio of 14.7 to 1 by constantly adjusting injector pulse width. Injector pulse width is the length of time that the injector opens and sprays fuel into the chamber. The PCM adjusts injector pulse width by opening and closing the ground path to the injector.

Manifold absolute pressure (air density) and engine rpm (speed) are the primary inputs that determine fuel injector pulse width. The PCM also monitors other inputs when adjusting air-fuel ratio.

Inputs That Effect Fuel Injector Pulse Width

- Exhaust gas oxygen content
- Engine coolant temperature
- Manifold absolute pressure (MAP)
- Engine speed
- Throttle position
- Battery voltage
- Air conditioning selection
- Transmission gear selection (automatic transmissions only)
- Speed control

The powertrain control module (PCM) adjusts ignition timing by controlling ignition coil operation. The ignition coil receives battery voltage when the ignition key is in the run or starter position. The PCM provides a ground for the ignition coil. The coil dis-

charges when the PCM supplies a ground. By switching the ground path on and off, the PCM regulates ignition timing.

The sensors and switches that provide inputs to the powertrain control module (PCM) comprise the Engine Control System. It is also comprised of the PCM Outputs (engine control devices that are operated by the PCM).

SYSTEM DIAGNOSIS

The powertrain control module (PCM) tests many of its own input and output circuits. If a Diagnostic Trouble Code (DTC) is found in a major system, this information is stored in the PCM memory. Refer to On-Board Diagnostics in the MFI System—General Diagnosis section of this group for DTC information.

POWERTRAIN CONTROL MODULE (PCM)

The PCM operates the fuel system. The PCM was formerly referred to as the SBEC or engine controller. The PCM is a pre-programmed, dual microprocessor digital computer. It regulates ignition timing, air-fuel ratio, emission control devices, charging system, speed control, air conditioning compressor clutch engagement and idle speed. The PCM can adapt its programming to meet changing operating conditions.

On XJ models, the PCM is located in the engine compartment next to the air cleaner (Fig. 1). On YJ models, the PCM is located in the engine compartment behind the windshield washer fluid reservoir (Fig. 2).

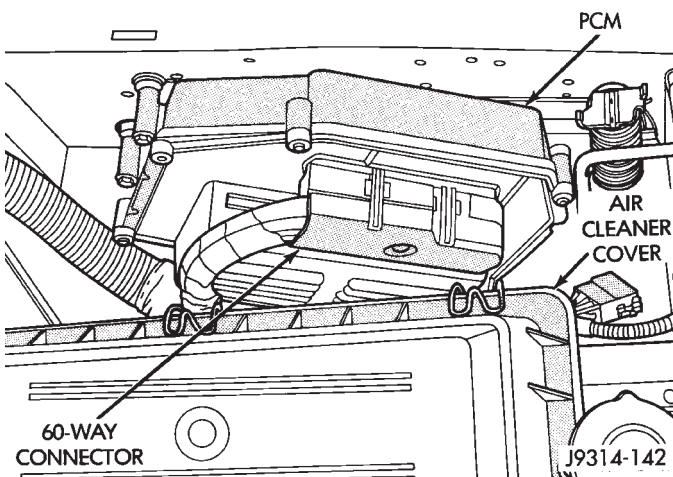

Fig. 1 PCM Location—XJ Models

The PCM receives input signals from various switches and sensors. Based on these inputs, the PCM regulates various engine and vehicle operations through different system components. These components are referred to as PCM Outputs. The sensors and switches that provide inputs to the PCM are considered PCM Inputs.

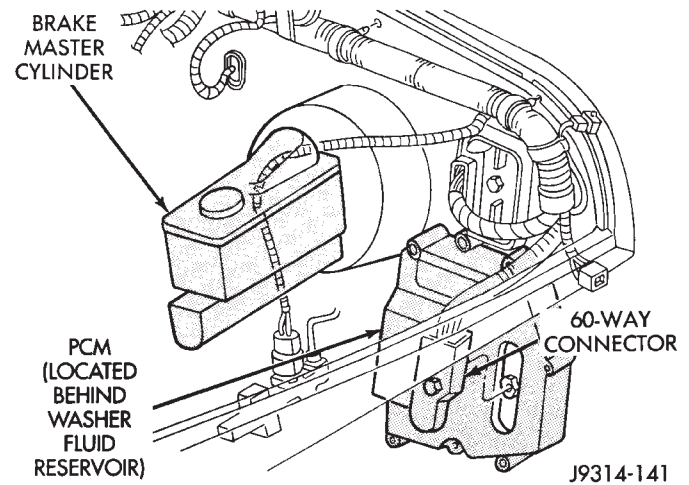

Fig. 2 PCM Location—YJ Models

The PCM adjusts ignition timing based upon inputs it receives from sensors that react to: engine rpm, manifold absolute pressure, coolant temperature, throttle position, transmission gear selection (automatic transmission), vehicle speed and the brake switch.

The PCM adjusts idle speed based on inputs it receives from sensors that react to: throttle position, vehicle speed, transmission gear selection, coolant temperature and from inputs it receives from the air conditioning clutch switch and brake switch.

Based on inputs that it receives, the PCM adjusts ignition coil dwell. The PCM also adjusts the generator charge rate through control of the generator field and provides speed control operation.

Powertrain Control Module (PCM) Inputs:

- Generator output
- A/C request (if equipped with factory A/C)
- A/C select (if equipped with factory A/C)
- Auto shut down (ASD) sense
- Intake air temperature sensor
- Battery voltage
- Brake switch
- Engine coolant temperature sensor
- Crankshaft position sensor
- Ignition circuit sense (ignition switch in run position)
- Manifold absolute pressure sensor
- Overdrive/override switch
- Oxygen sensor
- Park/neutral switch (auto. trans. only)
- SCI receive (DRB scan tool connection)
- Speed control resume switch
- Speed control set switch
- Speed control on/off switch
- Camshaft position sensor signal
- Throttle position sensor
- Vehicle speed sensor
- Sensor return
- Power ground

- Signal ground
- **Powertrain Control Module (PCM) Outputs**
- A/C clutch relay
- Idle air control (IAC) motor
- Auto shut down (ASD) relay
- Generator field
- Malfunction indicator lamp
- Fuel injectors
- Fuel pump relay
- Ignition coil
- SCI transmit (DRB scan tool connection)
- Shift indicator lamp (manual transmission only)
- Speed control vacuum solenoid
- Speed control vent solenoid
- Tachometer (on instrument panel, if equipped)
- Torque converter clutch relay (3-speed auto. trans. only)

The PCM contains a voltage convertor. This converts battery voltage to a regulated 8.0 volts. It is used to power the crankshaft position sensor and camshaft position sensor. The PCM also provides a five (5) volt supply for the Manifold Absolute Pressure (MAP) sensor and Throttle Position Sensor (TPS).

AIR CONDITIONING (A/C) CONTROLS—PCM INPUT

The A/C control system information applies to factory installed air conditioning units only.

A/C SELECT SIGNAL: When the A/C switch is in the ON position and the A/C low pressure switch is closed, an input signal is sent to the powertrain control module (PCM). The signal informs the PCM that the A/C has been selected. The PCM adjusts idle speed to a pre-programmed rpm through the idle air control (IAC) motor to compensate for increased engine load.

A/C REQUEST SIGNAL: Once A/C has been selected, the PCM receives the A/C request signal from the evaporator switch. The input indicates that the evaporator temperature is in the proper range for A/C application. The PCM uses this input to cycle the A/C compressor clutch (through the A/C relay). It will also determine the correct engine idle speed through the IAC motor position.

If the A/C low pressure switch opens (indicating a low refrigerant level), the PCM will not receive an A/C select signal. The PCM will then remove the ground from the A/C relay. This will deactivate the A/C compressor clutch.

If the evaporator switch opens, (indicating that evaporator is not in proper temperature range), the PCM will not receive the A/C request signal. The PCM will then remove the ground from the A/C relay, deactivating the A/C compressor clutch.

AUTOMATIC SHUT DOWN (ASD) SENSE—PCM INPUT

A 12 volt signal at this input indicates to the PCM that the ASD has been activated. The ASD relay is located in the power distribution center (PDC) in the engine compartment (Figs. 3 or 4). It is used to connect oxygen sensor heater element, ignition coil, generator field winding and fuel injectors to 12 volt + power supply. Also refer to Automatic Shut Down Relay—PCM Output.

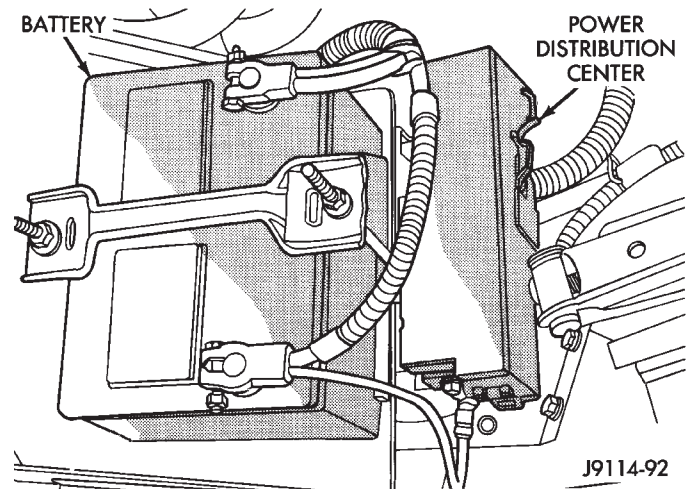

Fig. 3 Power Distribution Center—YJ Models

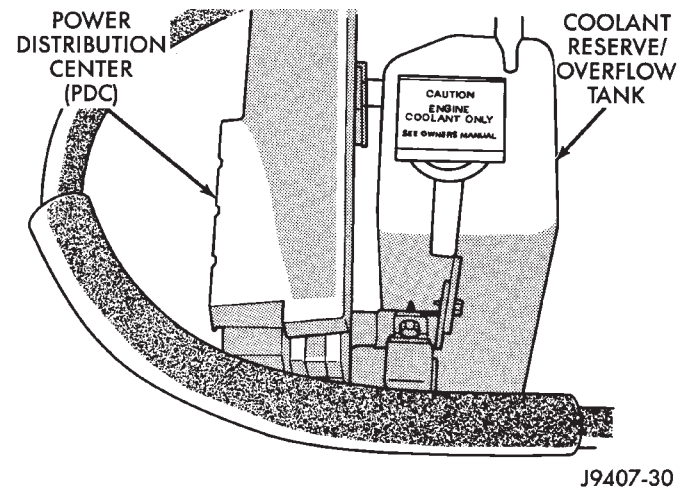

Fig. 4 Power Distribution Center—XJ Models

This input is used only to sense that the ASD relay is energized. If the PCM does not see 12 volts at this input when the ASD should be activated, it will set a Diagnostic Trouble Code (DTC).

BATTERY VOLTAGE—PCM INPUT

The battery voltage input provides power to the powertrain control module (PCM). It also informs the PCM what voltage level is supplied to the ignition coil and fuel injectors.

If battery voltage is low, the PCM will increase injector pulse width (period of time that the injector is

energized). This is done to compensate for the reduced flow through injector caused by the lowered voltage.

BRAKE SWITCH—PCM INPUT

When the brake light switch is activated, the powertrain control module (PCM) receives an input indicating that the brakes are being applied. After receiving this input, the PCM maintains idle speed to a scheduled rpm through control of the idle air control (IAC) motor. The brake switch input is also used to operate the speed control system.

CAMSHAFT POSITION SENSOR—PCM INPUT

A sync signal is provided by the camshaft position sensor located in the ignition distributor (Fig. 5). The sync signal from this sensor works in conjunction with the crankshaft position sensor to provide the powertrain control module (PCM) with inputs. This is done to establish and maintain correct injector firing order.

Refer to Camshaft Position Sensor in Group 8D, Ignition System for more information.

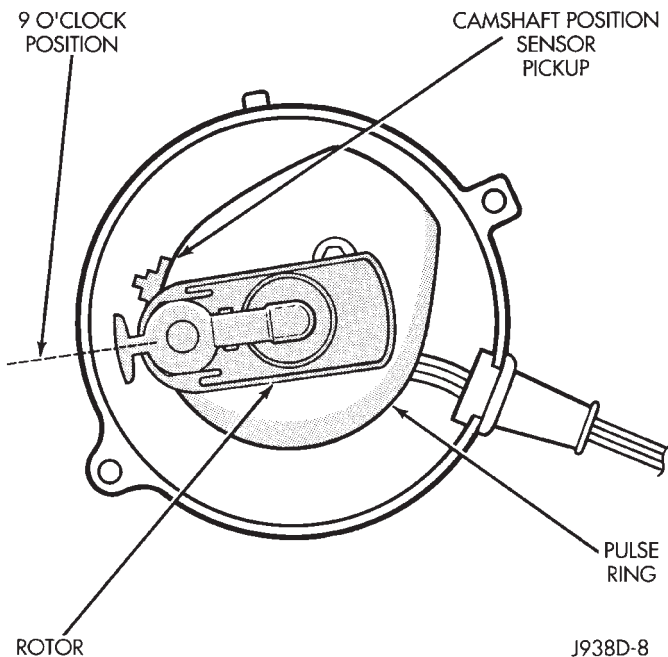

Fig. 5 Camshaft Position Sensor

DATA LINK CONNECTOR—PCM INPUT

The data link connector (diagnostic scan tool connector) links the DRB scan tool with the powertrain control module (PCM). The data link connector is located in the engine compartment (Figs. 6 or 7). For operation of the DRB scan tool, refer to the appropriate Powertrain Diagnostic Procedures service manual.

The data link connector uses two different pins on the PCM. One is for Data Link Transmit and the other is for Data Link Receive.

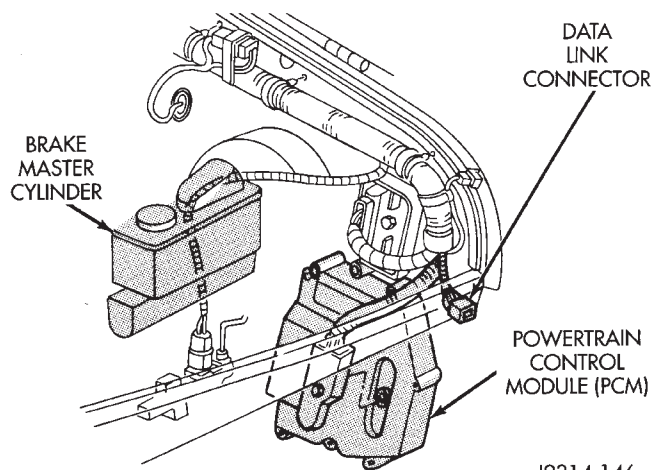

Fig. 6 Data Link Connector—YJ Models—Typical

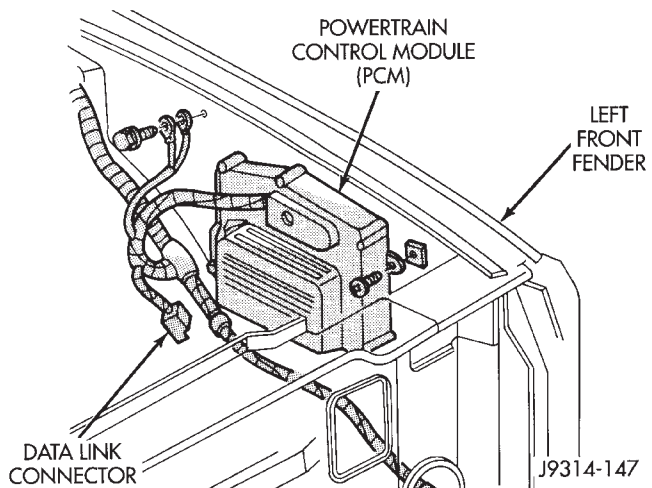

Fig. 7 Data Link Connector—XJ Models—Typical

INTAKE AIR TEMPERATURE SENSOR—PCM INPUT

The intake manifold air temperature sensor is installed in the intake manifold with the sensor element extending into the air stream (Figs. 8 or 9). The sensor provides an input voltage to the powertrain control module (PCM) indicating intake manifold air temperature. The input is used along with inputs from other sensors to determine injector pulse width. As the temperature of the air-fuel stream in the manifold varies, the sensor resistance changes. This results in a different input voltage to the PCM.

CRANKSHAFT POSITION SENSOR—PCM INPUT

This sensor is a Hall Effect device that detects notches in the flywheel (manual transmission), or flexplate (automatic transmission).

This sensor is used to indicate to the powertrain control module (PCM) that a spark and or fuel injection event is to be required. The output from this sensor, in conjunction with the camshaft position sensor signal, is used to differentiate between fuel injection and spark events. It is also used to synchronize the fuel injectors with their respective cylinders.

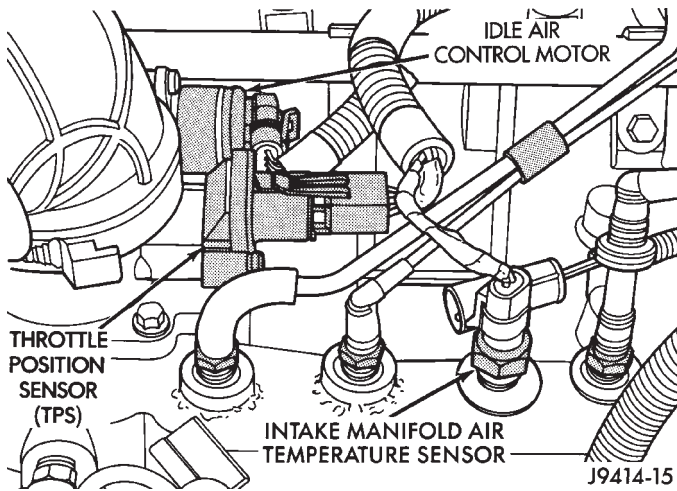

Fig. 8 Sensor Location—4.0L Engine

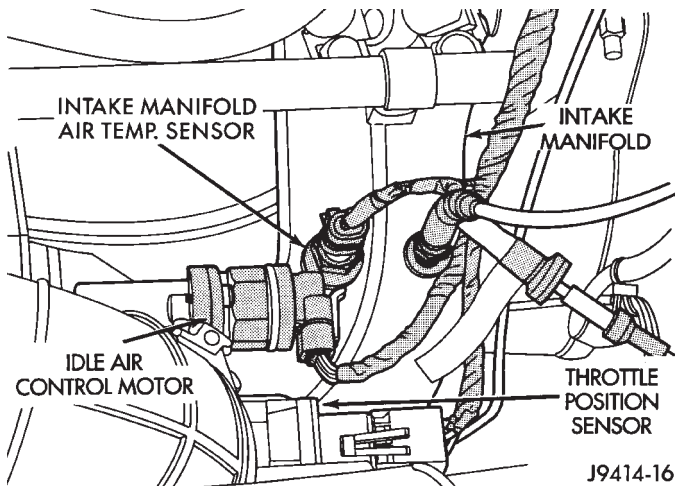

Fig. 9 Sensor Location—2.5L Engine

Refer to Group 8D, Ignition System for more crankshaft position sensor information.

The engine will not operate if the PCM does not receive a crankshaft position sensor input.

ENGINE COOLANT TEMPERATURE SENSOR—PCM INPUT

The coolant temperature sensor is installed in the thermostat housing (Fig. 10) and protrudes into the water jacket. The sensor provides an input voltage to the powertrain control module (PCM) relating coolant temperature. The PCM uses this input along with inputs from other sensors to determine injector pulse width and ignition timing. As coolant temperature varies, the coolant temperature sensor's resistance changes. The change in resistance results in a different input voltage to the PCM.

When the engine is cold, the PCM will operate in Open Loop cycle. It will demand slightly richer air-fuel mixtures and higher idle speeds. This is done until normal operating temperatures are reached.

Refer to Open Loop/Closed Loop Modes of Operation in this section of the group for more information.

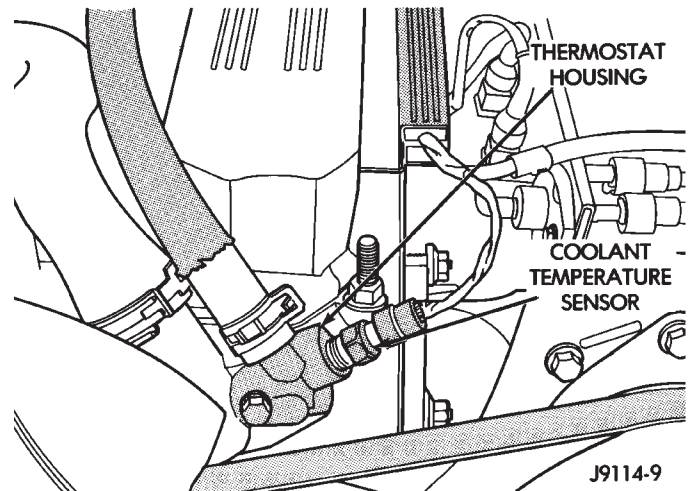

Fig. 10 Coolant Temperature Sensor—Typical
EXTENDED IDLE SWITCH—PCM INPUT

OPTIONAL POLICE PACKAGE ONLY

The extended idle switch is used to raise the engine idle speed to approximately 1000 rpm. This is when the shifter is in either the Park or Neutral position. A rocker-type 2-wire switch (extended idle switch) is mounted to the instrument panel. This switch will supply a ground circuit to the powertrain control module (PCM). **The switch is available only with 4.0L engine when supplied with the optional police package.**

For testing and diagnosis of this switch and its circuit, refer to the MFI System—General Diagnosis section of this group.

IGNITION CIRCUIT SENSE—PCM INPUT

The ignition circuit sense input tells the powertrain control module (PCM) the ignition switch has energized the ignition circuit. Refer to the wiring diagrams for circuit information.

MANIFOLD ABSOLUTE PRESSURE (MAP) SENSOR—PCM INPUT

The MAP sensor reacts to absolute pressure in the intake manifold. It provides an input voltage to the powertrain control module (PCM). As engine load changes, manifold pressure varies. The change in manifold pressure causes MAP sensor voltage to change. The change in MAP sensor voltage results in a different input voltage to the PCM. The input voltage level supplies the PCM with information about ambient barometric pressure during engine start-up (cranking) and engine load while the engine is running. The PCM uses this input along with inputs from other sensors to adjust air-fuel mixture.

The MAP sensor is mounted on the dash panel. The sensor is connected to the throttle body with a vacuum hose and to the PCM electrically.

OVERDRIVE/OVERRIDE SWITCH

On vehicles equipped with overdrive, the powertrain control module (PCM) regulates the 3-4 overdrive up-shift and down-shift through the overdrive solenoid.

Refer to Group 21 for more information.

OXYGEN (O2S) SENSOR—PCM INPUT

The O2S sensor is located in the exhaust down pipe (Fig. 11). It provides an input voltage to the powertrain control module (PCM) relating the oxygen content of the exhaust gas. The PCM uses this information to fine tune the air-fuel ratio by adjusting injector pulse width.

The O2S sensor produces voltages from 0 to 1 volt. This voltage will depend upon the oxygen content of the exhaust gas in the exhaust manifold. When a large amount of oxygen is present (caused by a lean air-fuel mixture), the sensor produces a low voltage. When there is a lesser amount present (rich air-fuel mixture) it produces a higher voltage. By monitoring the oxygen content and converting it to electrical voltage, the sensor acts as a rich-lean switch.

The oxygen sensor is equipped with a heating element that keeps the sensor at proper operating temperature during all operating modes. Maintaining correct sensor temperature at all times allows the system to enter into closed loop operation sooner.

In Closed Loop operation, the powertrain control module (PCM) monitors the O2S sensor input (along with other inputs). It then adjusts the injector pulse width accordingly. During Open Loop operation, the PCM ignores the O2S sensor input and adjusts injector pulse width to a preprogrammed value (based on other sensor inputs).

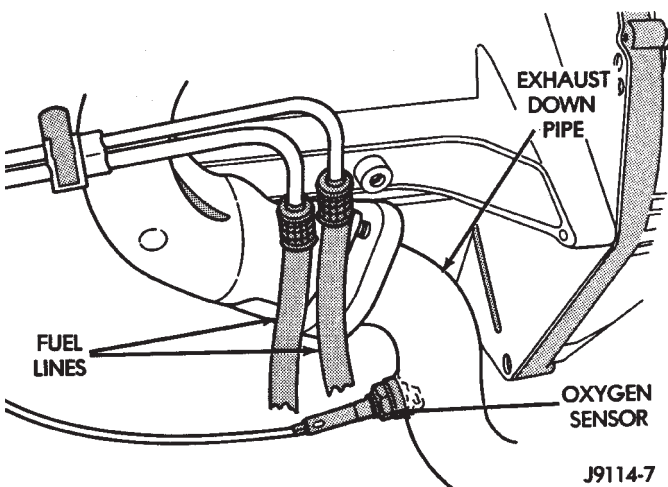

Fig. 11 Heated Oxygen Sensor Location—Typical

PARK/NEUTRAL SWITCH—PCM INPUT

The park/neutral switch is located on the transmission housing and provides an input to the powertrain control module (PCM). This will indicate that the automatic transmission is in Park, Neutral or a drive

gear selection. This input is used to determine idle speed (varying with gear selection), fuel injector pulse width and ignition timing advance. Refer to Group 21, Transmissions, for testing, replacement and adjustment information.

POWER GROUND

The power ground is used to control ground circuits for the following powertrain control module (PCM) loads:

- Generator Field Winding
- 8 volt (PCM) power supply
- Fuel Injectors
- Ignition Coil

POWER STEERING PRESSURE SWITCH—PCM INPUT

A pressure sensing switch is included in the power steering system (mounted on the high-pressure line). This switch will be on vehicles equipped with a 2.5L engine and power steering. The switch (Fig. 12 YJ Models or Fig. 13 XJ Models) provides an input to the PCM. This input is provided during periods of high pump load and low engine rpm; such as during parking maneuvers. The PCM will then increase the idle speed through the idle air control (IAC) motor. This is done to prevent the engine from stalling under the increased load.

When steering pump pressure exceeds $1896 \text{ kPa} \pm 172 \text{ kPa}$ ($275 \pm 25 \text{ psi}$) the PCM will increase the engine idle speed. This will prevent the engine from stalling.

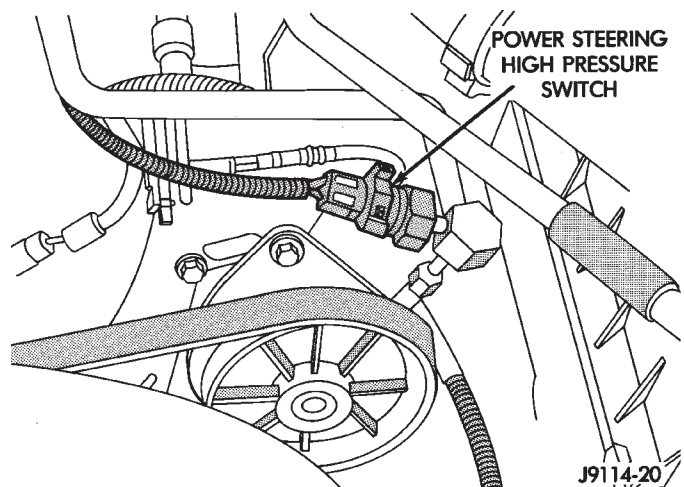

Fig. 12 Power Steering Pump Pressure Switch—YJ Models

SCI RECEIVE—PCM INPUT

SCI Receive is the serial data communication receive circuit for the DRB scan tool. The powertrain control module (PCM) receives data from the DRB through the SCI Receive circuit.

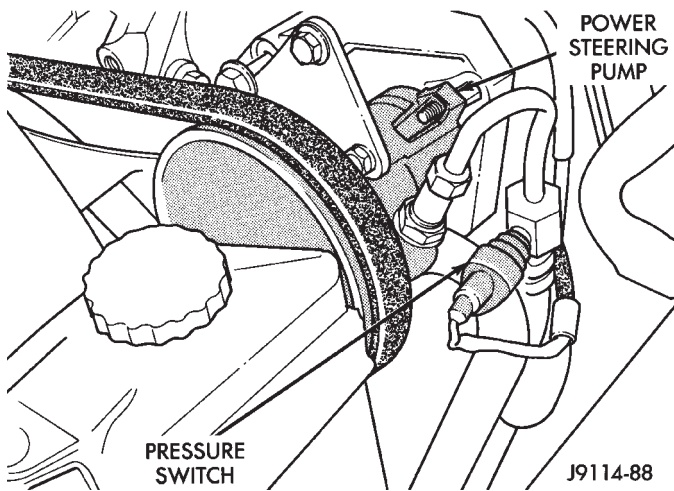

Fig. 13 Power Steering Pump Pressure Switch—XJ Models

SPEED CONTROL—PCM INPUT

The speed control system provides three separate inputs to the powertrain control module (PCM); On/Off, Set and Resume. The On/Off input informs the PCM that the speed control system has been activated. The Set input informs the PCM that a fixed vehicle speed has been selected. The Resume input indicates to the PCM that the previous fixed speed is requested.

The speed control operating range is from 50 km/h to 142 km/h (35 to 85 mph). Inputs that effect speed control operation are:

- Park/neutral switch
- Vehicle speed sensor
- Throttle position sensor

Refer to Group 8H for further speed control information.

SENSOR RETURN—PCM INPUT

Sensor Return provides a low noise ground reference for all system sensors.

THROTTLE POSITION SENSOR (TPS)—PCM INPUT

The Throttle Position Sensor (TPS) is mounted on the throttle body (Figs. 14 or 15). The TPS is a variable resistor that provides the powertrain control module (PCM) with an input signal (voltage) that represents throttle blade position. The sensor is connected to the throttle blade shaft. As the position of the throttle blade changes, the resistance of the TPS changes.

The PCM supplies approximately 5 volts to the TPS. The TPS output voltage (input signal to the PCM) represents the throttle blade position. The PCM receives an input signal voltage from the TPS. This will vary in an approximate range of from 1 volt at minimum throttle opening (idle), to 4 volts at wide open throttle. Along with inputs from other sensors, the PCM uses the TPS input to determine cur-

rent engine operating conditions. In response to engine operating conditions, the PCM will adjust fuel injector pulse width and ignition timing.

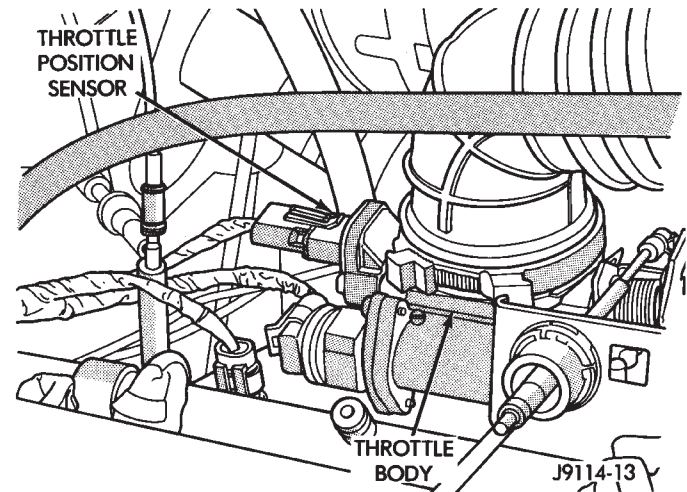

Fig. 14 Throttle Position Sensor—2.5L Engine

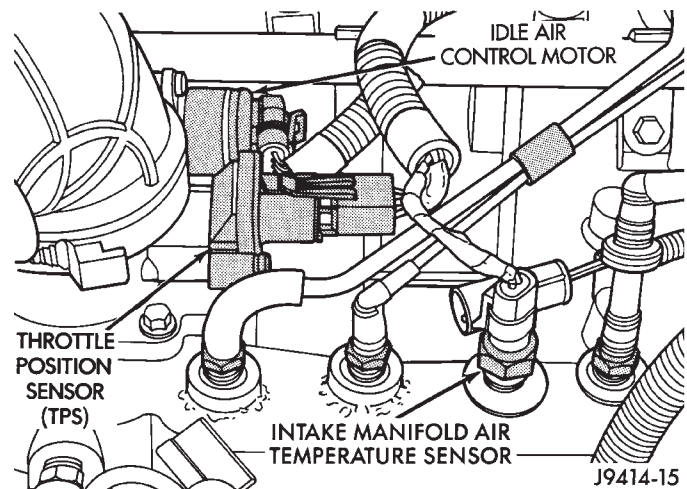

Fig. 15 Throttle Position Sensor—4.0L Engine

VEHICLE SPEED SENSOR—PCM INPUT

The vehicle speed sensor (Fig. 16) is located in the extension housing of the transmission (2 wheel drive) or on the transfer case extension housing (4 wheel drive). The sensor input is used by the powertrain control module (PCM) to determine vehicle speed and distance traveled.

The speed sensor generates 8 pulses per sensor revolution. These signals, in conjunction with a closed throttle signal from the throttle position sensor, indicate a closed throttle deceleration to the PCM. When the vehicle is stopped at idle, a closed throttle signal is received by the PCM (but a speed sensor signal is not received).

Under deceleration conditions, the PCM adjusts the idle air control (IAC) motor to maintain a desired MAP value. Under idle conditions, the PCM adjusts the IAC motor to maintain a desired engine speed.

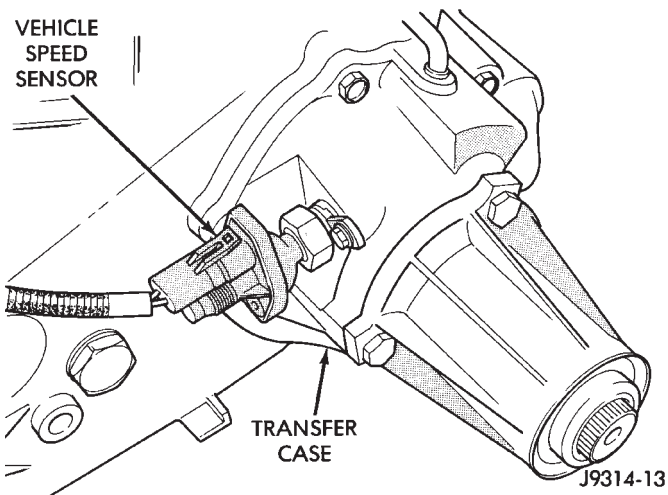

Fig. 16 Vehicle Speed Sensor—Typical

AIR CONDITIONING (A/C) CLUTCH RELAY—PCM OUTPUT

The powertrain control module (PCM) activates the A/C compressor through the A/C clutch relay. The PCM regulates A/C compressor operation by switching the ground circuit for the A/C clutch relay on and off. The relay is located in the Power Distribution Center (PDC) (Figs. 17 or 18). For the location of the relay within the PDC, refer to label on PDC cover.

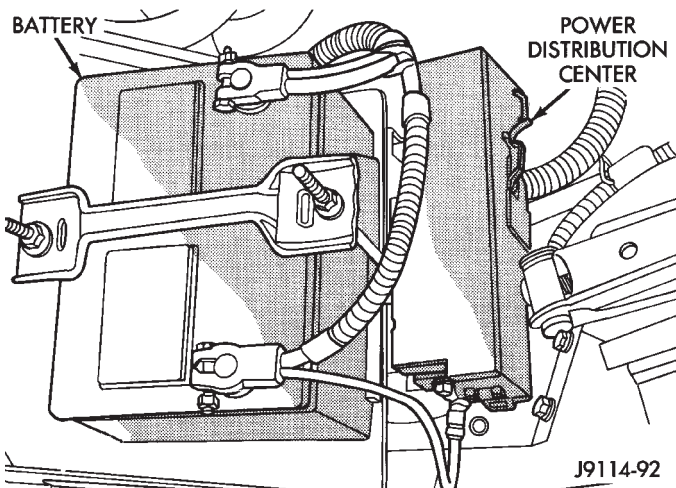

Fig. 17 PDC—YJ Models

When the PCM receives a request for A/C from A/C evaporator switch, it will adjust idle air control (IAC) motor position. This is done to increase idle speed. The PCM will then activate the A/C clutch through the A/C clutch relay. The PCM adjusts idle air control (IAC) stepper motor position to compensate for increased engine load from the A/C compressor.

By switching the ground path for the relay on and off, the PCM is able to cycle the A/C compressor clutch. This is based on changes in engine operating conditions. If, during A/C operation, the PCM senses low idle speeds or a wide open throttle condition, it

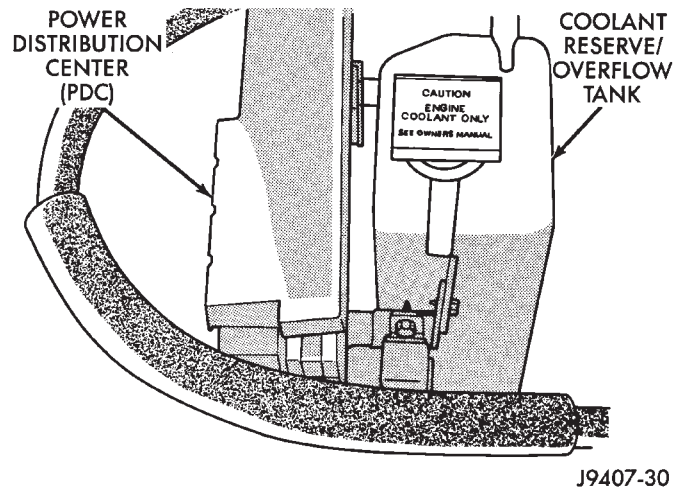

Fig. 18 PDC—XJ Models

will de-energize the relay. This prevents A/C clutch engagement. The relay will remain de-energized until the idle speed increases or the wide open throttle condition exceeds 15 seconds or no longer exists. The PCM will also de-energize the relay if coolant temperature exceeds 125°C (257°F).

AUTO SHUT DOWN (ASD) RELAY—PCM OUTPUT

The ASD relay is located in the Power Distribution Center (PDC) (Figs. 17 or 18). For the location of this relay within the PDC, refer to label on PDC cover.

The ASD supplies battery voltage to the fuel pump, fuel injector, ignition coil, generator field winding and oxygen (O₂S) sensor heating element. The ground circuit for the coil in the ASD relay is controlled by the powertrain control module (PCM). The PCM operates the relay by switching the ground circuit on and off.

The fuel pump relay is controlled by the PCM through same circuit that the ASD relay is controlled.

The powertrain control module (PCM) energizes the fuel pump through the fuel pump relay. (The PCM was formerly referred to as the SBEC or engine controller). Battery voltage is applied to the relay from the ignition switch. The relay is energized when a ground is provided by the PCM. The relay is located in the Power Distribution Center (PDC) (Figs. 17 or 18). For the location of fuel pump relay within PDC, refer to label on PDC cover.

For the 1994 model year, the ballast resistor and ballast resistor bypass relay are no longer used to control the fuel pump circuit.

DATA LINK CONNECTOR—PCM OUTPUT

Refer to the previous paragraphs on Data Link Connector—PCM Input for information.

EMR LAMP—PCM OUTPUT

The EMR lamp is not used for the 1994 model year.

FUEL PUMP RELAY—PCM OUTPUT

The PCM energizes the fuel pump through the fuel pump relay. Battery voltage is applied to the relay from the ignition switch. The relay is energized when a ground is provided by the PCM. Refer to Automatic Shut Down Relay for additional information.

FUEL INJECTORS—PCM OUTPUT

Six individual fuel injectors are used with the 4.0L 6 cylinder engine. Four individual fuel injectors are used with the 2.5L 4 cylinder engine. The injectors are attached to the fuel rail (Fig. 19).

The nozzle ends of the injectors are positioned into openings in the intake manifold just above the intake valve ports of the cylinder head. The engine wiring harness connector for each fuel injector is equipped with an attached numerical tag (INJ 1, INJ 2 etc.). This is used to identify each fuel injector.

The injectors are energized individually in a sequential order by the powertrain control module (PCM). The PCM will adjust injector pulse width by switching the ground path to each individual injector on and off. Injector pulse width is the period of time that the injector is energized. The PCM will adjust injector pulse width based on various inputs it receives.

During start up, battery voltage is supplied to the injectors through the ASD relay. When the engine is operating, voltage is supplied by the charging system. The PCM determines injector pulse width based on various inputs.

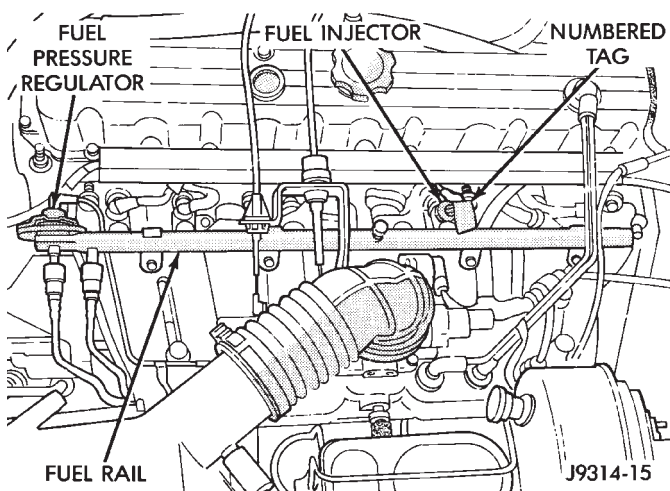

Fig. 19 Fuel Injectors—Typical

GENERATOR FIELD—PCM OUTPUT

The powertrain control module (PCM) regulates the charging system voltage within a range of 12.9 to 15.0 volts. Refer to Group 8A for charging system information.

GENERATOR LAMP—PCM OUTPUT

IF EQUIPPED

If the powertrain control module (PCM) senses a low charging condition in the charging system, it will illuminate the generator lamp on the instrument panel. For example, during low idle with all accessories turned on, the light may momentarily go on. Once the PCM corrects idle speed to a higher rpm, the light will go out. Refer to Group 8A, Battery/Starting/Charging Systems for charging system information.

IDLE AIR CONTROL (IAC) MOTOR—PCM OUTPUT

The IAC motor is mounted on the throttle body (Figs. 20 or 21) and is controlled by the powertrain control module (PCM).

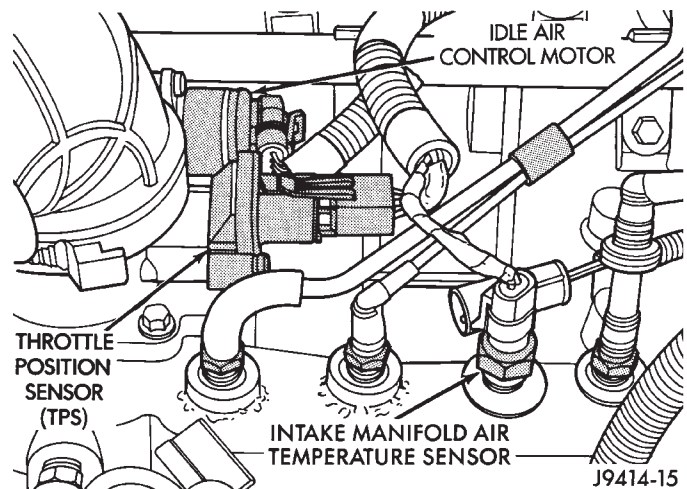

Fig. 20 IAC Motor—4.0L Engine

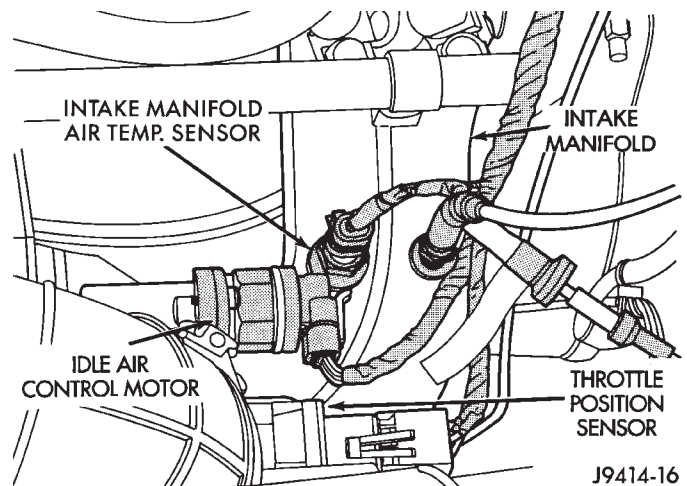

Fig. 21 IAC Motor—2.5L Engine

The throttle body has an air control passage that provides air for the engine at idle (the throttle plate is closed). The IAC motor pintle protrudes into the air control passage and regulates air flow through it. Based on various sensor inputs, the powertrain control module (PCM) adjusts engine idle speed by mov-

ing the IAC motor pintle in and out of the air control passage. The IAC motor is positioned when the ignition key is turned to the On position.

A (factory adjusted) set screw is used to mechanically limit the position of the throttle body throttle plate. **Never attempt to adjust the engine idle speed using this screw.** All idle speed functions are controlled by the PCM.

IGNITION COIL—PCM OUTPUT

System voltage is supplied to the ignition coil positive terminal. The powertrain control module (PCM) operates the ignition coil. **Base (initial) ignition timing is not adjustable.** The PCM adjusts ignition timing to meet changing engine operating conditions.

The ignition coil is located near the ignition distributor (Fig. 22).

Refer to Group 8D, Ignition System for additional information.

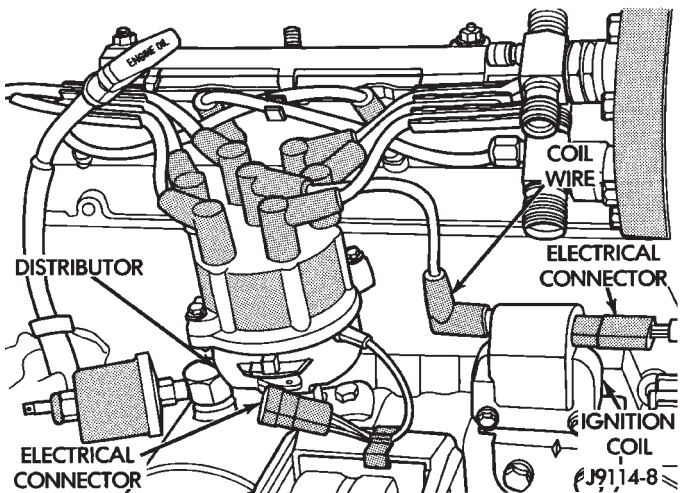

Fig. 22 Ignition Coil—Typical

MALFUNCTION INDICATOR LAMP—PCM OUTPUT

The Malfunction Indicator Lamp (formerly referred to as the Check Engine Lamp) illuminates on the instrument panel each time the ignition key is turned on. It will stay on for three seconds as a bulb test.

If the powertrain control module (PCM) receives an incorrect signal, or no signal from certain sensors or emission related systems, the lamp is turned on. This is a warning that the PCM has recorded a system or sensor malfunction. In some cases, when a problem is declared, the PCM will go into a limp-in mode. This is an attempt to keep the system operating. It signals an immediate need for service.

The lamp can also be used to display a Diagnostic Trouble Code (DTC). Cycle the ignition switch On-Off-On-Off-On within three seconds and any codes stored in the PCM memory will be displayed. This is done in a series of flashes representing digits. Refer to On-Board Diagnostics in the General Diagnosis section of this group for more information.

RADIATOR FAN RELAY—PCM OUTPUT

XJ MODELS ONLY

The electric radiator cooling fan used in XJ models (equipped with 4.0L engine, heavy duty cooling and/or air conditioning) is controlled by the powertrain control module (PCM) through radiator fan relay. The relay is energized when coolant temperature is above 103°C (217°F). It will then de-energize when coolant temperature drops to 98°C (208°F). Refer to Group 7, Cooling Systems for more information.

The relay is located in the power distribution center (PDC) (Fig. 23).

The electric radiator cooling fan is not used on YJ models.

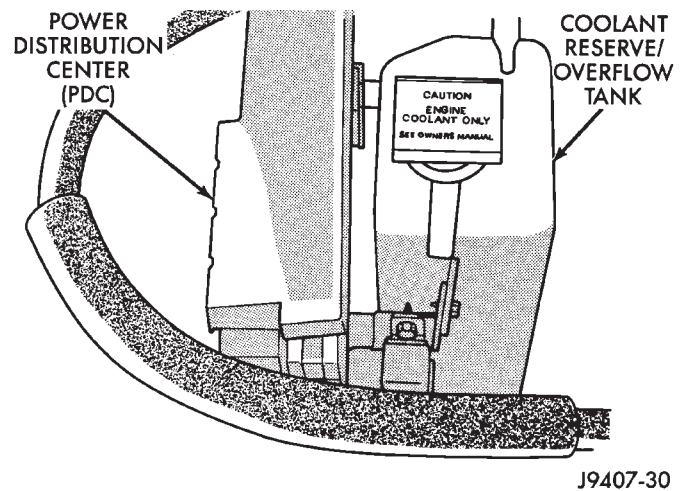

Fig. 23 PDC—XJ Models

SCI TRANSMIT—PCM OUTPUT

SCI Transmit is the serial data communication transmit circuit for the DRB scan tool. The powertrain control module (PCM) transmits data to the DRB through the SCI Transmit circuit.

SHIFT INDICATOR—PCM OUTPUT

Vehicles equipped with manual transmissions have an Up-Shift indicator lamp. The lamp is controlled by the powertrain control module (PCM). The lamp illuminates on the instrument panel to indicate when the driver should shift to the next highest gear for best fuel economy. The PCM will turn the lamp OFF after 3 to 5 seconds if the shift of gears is not performed. The up-shift light will remain off until vehicle stops accelerating and is brought back to range of up-shift light operation. This will also happen if vehicle is shifted into fifth gear.

The indicator lamp is normally illuminated when the ignition switch is turned on and it is turned off when the engine is started up. With the engine running, the lamp is turned on/off depending upon engine speed and load.

SPEED CONTROL—PCM OUTPUT

Speed control operation is regulated by the powertrain control module (PCM). The PCM controls the vacuum to the throttle actuator through the speed control vacuum and vent solenoids. Refer to Group 8H for speed control information.

TACHOMETER—PCM OUTPUT

The powertrain control module (PCM) supplies engine rpm values to the instrument cluster tachometer (if equipped). Refer to Group 8E for tachometer information.

TORQUE CONVERTER CLUTCH RELAY—PCM OUTPUT

ALL 2.5L 4 CYL. WITH 3-SPEED AUTO. TRANS

4.0L 6 CYL. YJ MODELS WITH 3-SPEED AUTO. TRANS

The transmission mounted torque converter clutch (TCC) solenoid is used to control the torque converter. The solenoid is controlled through the powertrain control module (PCM) and by the TCC relay. This relay is used only on vehicles equipped with a 3-speed automatic transmission.

An electrical output signal is sent from the PCM to the TCC relay after the PCM receives information from the vehicle speed, MAP, throttle position and engine coolant temperature sensors. After the TCC relay receives this necessary information, it will send a signal to the torque converter clutch solenoid to control the torque converter.

On YJ models the TCC relay is located in the engine compartment, on the cowl panel and near the battery (Fig. 24). On XJ models the TCC relay is located in the power distribution center (PDC) (Fig. 23).

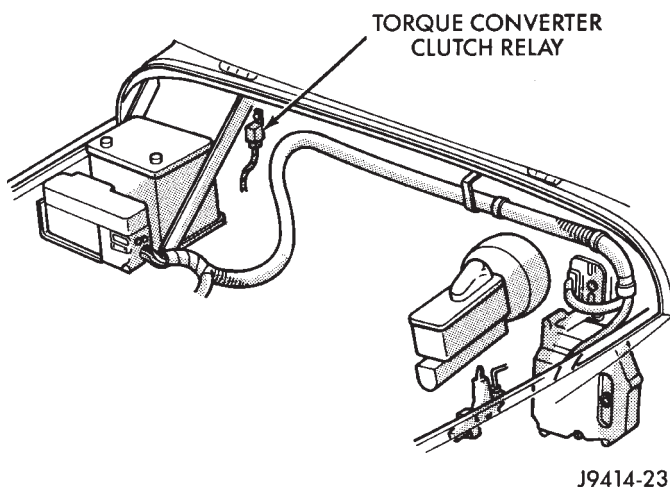

Fig. 24 TCC Relay Location—YJ Models

OPEN LOOP/CLOSED LOOP MODES OF OPERATION

As input signals to the powertrain control module (PCM) change, the PCM adjusts its response to the output devices. For example, the PCM must calculate different injector pulse width and ignition timing for idle than it does for wide open throttle (WOT). There are several different modes of operation that determine how the PCM responds to the various input signals.

MODES

- Open Loop
- Closed Loop

During Open Loop modes, the powertrain control module (PCM) receives input signals and responds only according to preset PCM programming. Input from the oxygen (O₂S) sensor is not monitored during Open Loop modes.

During Closed Loop modes, the PCM will monitor the oxygen (O₂S) sensor input. This input indicates to the PCM whether or not the calculated injector pulse width results in the ideal air-fuel ratio. This ratio is 14.7 parts air-to-1 part fuel. By monitoring the exhaust oxygen content through the O₂S sensor, the PCM can fine tune the injector pulse width. This is done to achieve optimum fuel economy combined with low emission engine performance.

The fuel injection system has the following modes of operation:

- Ignition switch ON
- Engine start-up (crank)
- Engine warm-up
- Idle
- Cruise
- Acceleration
- Deceleration
- Wide open throttle (WOT)
- Ignition switch OFF

The ignition switch On, engine start-up (crank), engine warm-up, acceleration, deceleration and wide open throttle modes are Open Loop modes. The idle and cruise modes, (with the engine at operating temperature) are Closed Loop modes.

IGNITION SWITCH (KEY-ON) MODE

This is an Open Loop mode. When the fuel system is activated by the ignition switch, the following actions occur:

- The powertrain control module (PCM) pre-positions the idle air control (IAC) motor.
- The PCM determines atmospheric air pressure from the MAP sensor input to determine basic fuel strategy.
- The PCM monitors the engine coolant temperature sensor input. The PCM modifies fuel strategy based on this input.

- Intake manifold air temperature sensor input is monitored
- Throttle position sensor (TPS) is monitored
- The auto shut down (ASD) relay is energized by the PCM for approximately three seconds.
- The fuel pump is energized through the fuel pump relay by the PCM. The fuel pump will operate for approximately one second unless the engine is operating or the starter motor is engaged
- The O₂S sensor heater element is energized through the fuel pump relay. The O₂S sensor input is not used by the PCM to calibrate air-fuel ratio during this mode of operation.
- The up-shift indicator light is illuminated (manual transmission only).

ENGINE START-UP MODE

This is an Open Loop mode. The following actions occur when the starter motor is engaged.

The powertrain control module (PCM) receives inputs from:

- Battery voltage
- Engine coolant temperature sensor
- Crankshaft position sensor
- Intake manifold air temperature sensor
- Manifold absolute pressure (MAP) sensor
- Throttle position sensor (TPS)
- Starter motor relay
- Camshaft position sensor signal

The PCM monitors the crankshaft position sensor. If the PCM does not receive a crankshaft position sensor signal within 3 seconds of cranking the engine, it will shut down the fuel injection system.

The fuel pump is activated by the PCM through the fuel pump relay.

Voltage is applied to the fuel injectors with the PCM. The PCM will then control the injection sequence and injector pulse width by turning the ground circuit to each individual injector on and off.

The PCM determines the proper ignition timing according to input received from the crankshaft position sensor.

ENGINE WARM-UP MODE

This is an Open Loop mode. During engine warm-up, the powertrain control module (PCM) receives inputs from:

- Battery voltage
- Crankshaft position sensor
- Engine coolant temperature sensor
- Intake manifold air temperature sensor
- Manifold absolute pressure (MAP) sensor
- Throttle position sensor (TPS)
- Camshaft position sensor signal (in the distributor)
- Park/Neutral Switch (Gear indicator signal—auto. trans. only)
- Air conditioning select signal (if equipped)
- Air conditioning request signal (if equipped)

Based on these inputs the following occurs:

- Voltage is applied to the fuel injectors with the powertrain control module (PCM). The PCM will then control the injection sequence and injector pulse width by turning the ground circuit to each individual injector on and off.
- The PCM adjusts engine idle speed through the idle air control (IAC) motor and adjusts ignition timing.
- The PCM operates the A/C compressor clutch through the clutch relay. This is done if A/C has been selected by the vehicle operator and requested by the A/C thermostat.
- If the vehicle has a manual transmission, the up-shift light is operated by the PCM.
- When engine has reached operating temperature, the PCM will begin monitoring O₂S sensor input. The system will then leave the warm-up mode and go into closed loop operation.

IDLE MODE

When the engine is at operating temperature, this is a Closed Loop mode. At idle speed, the powertrain control module (PCM) receives inputs from:

- Air conditioning select signal (if equipped)
- Air conditioning request signal (if equipped)
- Battery voltage
- Crankshaft position sensor
- Engine coolant temperature sensor
- Intake manifold air temperature sensor
- Manifold absolute pressure (MAP) sensor
- Throttle position sensor (TPS)
- Camshaft position sensor signal (in the distributor)
- Battery voltage
- Park/Neutral Switch (gear indicator signal—auto. trans. only)
- Oxygen sensor

Based on these inputs, the following occurs:

- Voltage is applied to the fuel injectors with the powertrain control module (PCM). The PCM will then control injection sequence and injector pulse width by turning the ground circuit to each individual injector on and off.
- The PCM monitors the O₂S sensor input and adjusts air-fuel ratio by varying injector pulse width. It also adjusts engine idle speed through the idle air control (IAC) motor.
- The PCM adjusts ignition timing by increasing and decreasing spark advance.
- The PCM operates the A/C compressor clutch through the clutch relay. This happens if A/C has been selected by the vehicle operator and requested by the A/C thermostat.

The optional Extended Idle Switch is used to raise the engine idle speed to approximately 1000 rpm. This is when the shifter is in either the Park or Neutral position. A rocker-type 2-wire switch (extended idle switch) is mounted to the instrument panel. This

switch will supply a ground circuit to the powertrain control module (PCM). **The switch is available only with 4.0L engine when supplied with the optional police package.**

CRUISE MODE

When the engine is at operating temperature, this is a Closed Loop mode. At cruising speed, the powertrain control module (PCM) receives inputs from:

- Air conditioning select signal (if equipped)
- Air conditioning request signal (if equipped)
- Battery voltage
- Engine coolant temperature sensor
- Crankshaft position sensor
- Intake manifold air temperature sensor
- Manifold absolute pressure (MAP) sensor
- Throttle position sensor (TPS)
- Camshaft position sensor signal (in the distributor)
- Park/Neutral switch (gear indicator signal—auto. trans. only)

- Oxygen (O₂S) sensor

Based on these inputs, the following occurs:

- Voltage is applied to the fuel injectors with the PCM. The PCM will then adjust the injector pulse width by turning the ground circuit to each individual injector on and off.
- The PCM monitors the O₂S sensor input and adjusts air-fuel ratio. It also adjusts engine idle speed through the idle air control (IAC) motor.
- The PCM adjusts ignition timing by turning the ground path to the coil on and off.
- The PCM operates the A/C compressor clutch through the clutch relay. This happens if A/C has been selected by the vehicle operator and requested by the A/C thermostat.

ACCELERATION MODE

This is an Open Loop mode. The powertrain control module (PCM) recognizes an abrupt increase in throttle position or MAP pressure as a demand for increased engine output and vehicle acceleration. The PCM increases injector pulse width in response to increased throttle opening.

DECELERATION MODE

When the engine is at operating temperature, this is an Open Loop mode. During hard deceleration, the powertrain control module (PCM) receives the following inputs.

- Air conditioning select signal (if equipped)
- Air conditioning request signal (if equipped)
- Battery voltage
- Engine coolant temperature sensor
- Crankshaft position sensor
- Intake manifold air temperature sensor
- Manifold absolute pressure (MAP) sensor
- Throttle position sensor (TPS)
- Camshaft position sensor signal (in the distributor)

- Park/Neutral switch (gear indicator signal—auto. trans. only)

If the vehicle is under hard deceleration with the proper rpm and closed throttle conditions, the PCM will ignore the oxygen sensor input signal. The PCM will enter a fuel cut-off strategy in which it will not supply battery voltage to the injectors. If a hard deceleration does not exist, the PCM will determine the proper injector pulse width and continue injection.

Based on the above inputs, the PCM will adjust engine idle speed through the idle air control (IAC) motor.

The PCM adjusts ignition timing by turning the ground path to the coil on and off.

The PCM opens the ground circuit to the A/C clutch relay to disengage the A/C compressor clutch. This is done until the vehicle is no longer under deceleration (if the A/C system is operating).

WIDE OPEN THROTTLE MODE

This is an Open Loop mode. During wide open throttle operation, the powertrain control module (PCM) receives the following inputs.

- Battery voltage
- Crankshaft position sensor
- Engine coolant temperature sensor
- Intake manifold air temperature sensor
- Manifold absolute pressure (MAP) sensor
- Throttle position sensor (TPS)
- Camshaft position sensor signal (in the distributor)

During wide open throttle conditions, the following occurs:

- Voltage is applied to the fuel injectors with the powertrain control module (PCM). The PCM will then control the injection sequence and injector pulse width by turning the ground circuit to each individual injector on and off. The PCM ignores the oxygen sensor input signal and provides a predetermined amount of additional fuel. This is done by adjusting injector pulse width.
- The PCM adjusts ignition timing by turning the ground path to the coil on and off.
- The PCM opens the ground circuit to the A/C clutch relay to disengage the A/C compressor clutch. This will be done for approximately 15 seconds (if the air conditioning system is operating).

If the vehicle has a manual transmission, the up-shift light is operated by the PCM.

IGNITION SWITCH OFF MODE

When ignition switch is turned to OFF position, the PCM stops operating the injectors, ignition coil, ASD relay and fuel pump relay.

THROTTLE BODY

Filtered air from the air cleaner enters the intake manifold through the throttle body (Fig. 25). Fuel does not enter the intake manifold through the throt-

tle body. Fuel is sprayed into the manifold by the fuel injectors. The throttle body is mounted on the intake manifold. It contains an air control passage (Fig. 26) controlled by an Idle Air Control (IAC) motor. The air control passage is used to supply air for idle conditions. A throttle valve (plate) is used to supply air for above idle conditions.

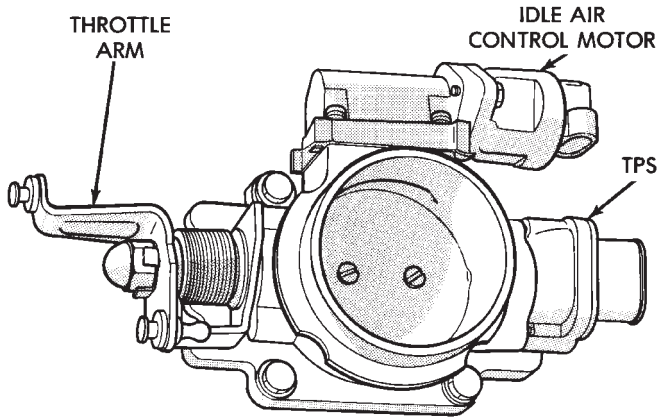

J9314-16

Fig. 25 Throttle Body—Typical

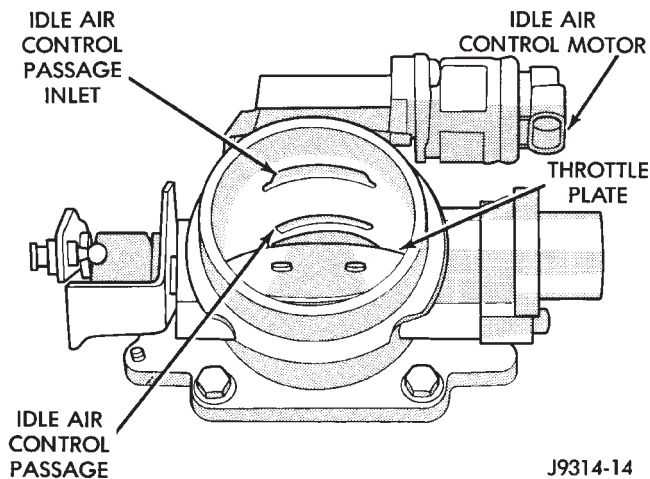

J9314-14

Fig. 26 Idle Air Control Passage

The throttle position sensor (TPS) and idle air control (IAC) motor are attached to the throttle body. The accelerator pedal cable, speed control cable and transmission control cable (when equipped) are connected to the throttle arm.

A (factory adjusted) set screw is used to mechanically limit the position of the throttle body throttle plate. **Never attempt to adjust the engine idle speed using this screw.** All idle speed functions are controlled by the PCM.

FUEL RAIL

The fuel rail supplies fuel to the injectors and is mounted to the intake manifold (Fig. 27). The fuel

pressure regulator is attached to the rail and the fuel pressure test port is integral with the rail. The fuel rail is not repairable.

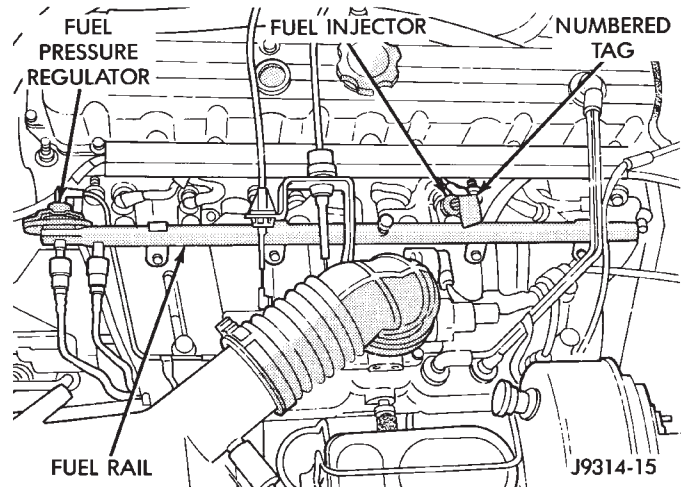

J9314-15

Fig. 27 Fuel Rail—Typical

FUEL PRESSURE REGULATOR

The fuel pressure regulator (Fig. 28) is a mechanical device that is not controlled by the powertrain control module (PCM).

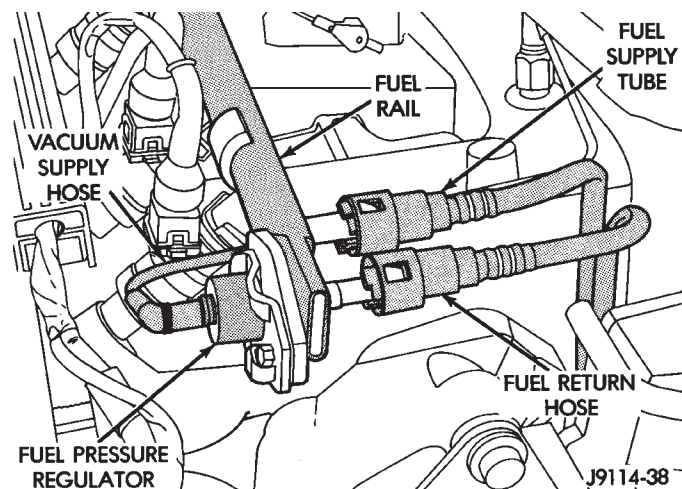

J9114-38

Fig. 28 Fuel Pressure Regulator—Typical

The fuel pressure regulator used is a vacuum balanced, nonadjustable type. The regulator is mounted on the output end of the fuel rail and is connected to intake manifold vacuum. The fuel return tube (to the fuel tank) is connected to the fuel pressure regulator.

The regulator is calibrated to maintain fuel system pressure at approximately 214 kPa (31 psi). This is with vacuum applied while the engine is at idle. Fuel pressure will be 55-69 kPa (8-10 psi) higher if vacuum is not applied to the regulator.

The pressure regulator contains a diaphragm, calibrated spring and a fuel return valve (Fig. 29). Fuel pressure operates on one side of the regulator, while spring pressure and intake manifold vacuum operate on the other side. Spring pressure on one side of the

diaphragm tries to force the return valve closed. Fuel pressure on other side of diaphragm, with assistance from manifold vacuum on spring side of diaphragm, act against spring pressure to open the return valve. System fuel pressure is the amount of fuel pressure required to force against spring pressure and unseat the return valve.

Without vacuum applied to the spring side of the regulator, the spring is calibrated to open the fuel return outlet. This happens when the pressure differential between the fuel injectors and the intake manifold reaches approximately 269 kPa (39 psi). Since manifold vacuum varies with engine operating conditions, the amount of vacuum applied to the spring side of the diaphragm varies. For this reason, fuel pressure varies, depending upon intake manifold vacuum. With low vacuum, such as during wide open throttle conditions, minimal vacuum assistance is available. Full spring pressure is exerted to seal the fuel outlet. This causes the system pressure to increase. With high vacuum, such as at engine idle or during vehicle deceleration, fuel pressure on one side of the diaphragm is balanced by intake manifold pressure. This is done on the spring side of the diaphragm and results in lower system fuel pressure.

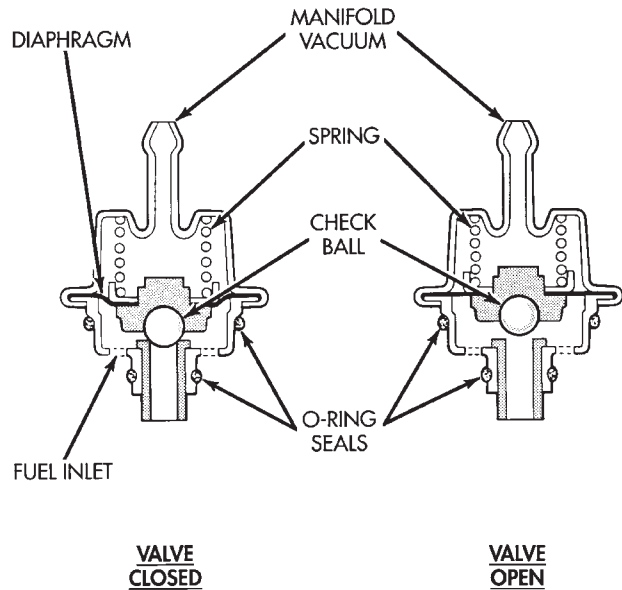

J9214-11

Fig. 29 Fuel Pressure Regulator Operation—Typical

MULTI-PORT FUEL INJECTION (MFI)—GENERAL DIAGNOSIS

INDEX

	page		page
Automatic Shutdown (ASD) Relay Testing	43	Manifold Absolute Pressure (MAP) Sensor Test	44
Camshaft Position Sensor Test	43	On-Board Diagnostics (OBD)	48
Crankshaft Position Sensor Test	44	Oxygen Sensor (O2S) Heating Element Test	45
Diagnostic Trouble Code (DTC)	51	Powertrain Control Module (PCM) 60-Way Connector	38
DRB Scan Tool	51	Relays—Operation/Testing	47
Engine Coolant Temperature Sensor Test	43	Starter Motor Relay Test	48
Extended Idle Switch Test	45	System Schematics	38
Fuel Pump Relay Testing	44	Throttle Position Sensor (TPS) Test	45
Fuel System Pressure Test	48	Torque Converter Clutch Relay Test	45
General Information	32	Vehicle Speed Sensor Test	45
Idle Air Control Motor Test	46	Visual Inspection	32
Injector Test	48		
Intake Air Temperature Sensor Test	43		

GENERAL INFORMATION

All 2.5L 4 cylinder and 4.0L 6 cylinder engines are equipped with sequential Multi-Port Fuel Injection (MFI). The MFI system provides precise air/fuel ratios for all driving conditions.

VISUAL INSPECTION

A visual inspection for loose, disconnected, or incorrectly routed wires and hoses should be made. This should be done before attempting to diagnose or service the fuel injection system. A visual check will help spot these faults and save unnecessary test and diagnostic time. A thorough visual inspection will include the following checks:

(1) Verify that the 60-way connector is fully inserted into the connector of the Powertrain Control Module (PCM) (Figs. 1 or 2). Verify that the connector mounting bolt is tightened to 4 N·m (35 in. lbs.) torque.

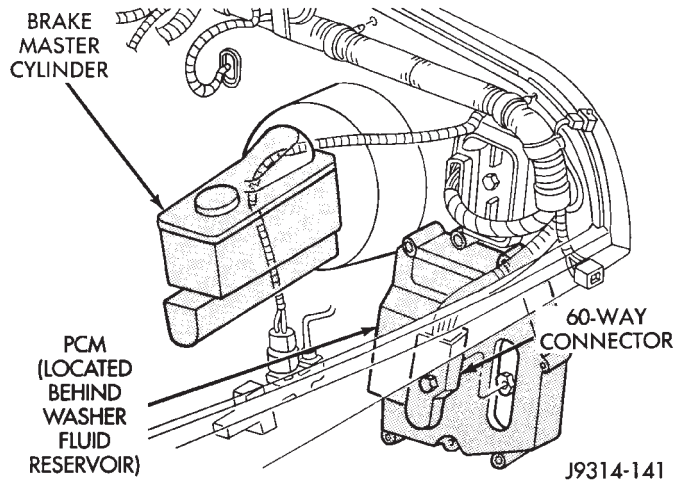

Fig. 1 PCM—YJ Models

(2) Inspect the battery cable connections. Be sure they are clean and tight.

(3) Inspect fuel pump relay and air conditioning compressor clutch relay (if equipped). Inspect ASD relay and

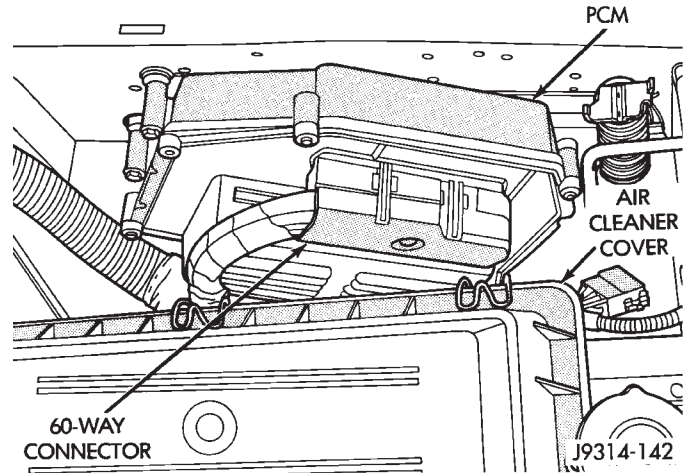

Fig. 2 PCM—XJ Models

radiator fan relay (if equipped) connections. Inspect starter motor relay connections. Inspect relays for signs of physical damage and corrosion. The relays are installed in the Power Distribution Center (PDC) (Figs. 3 or 4).

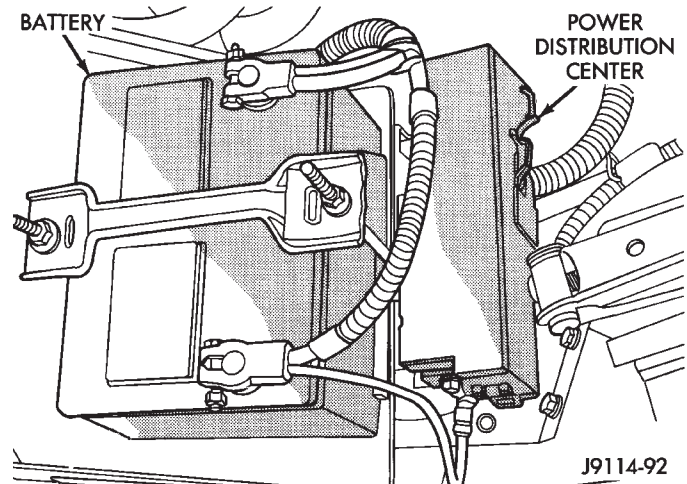

Fig. 3 PDC—YJ Models

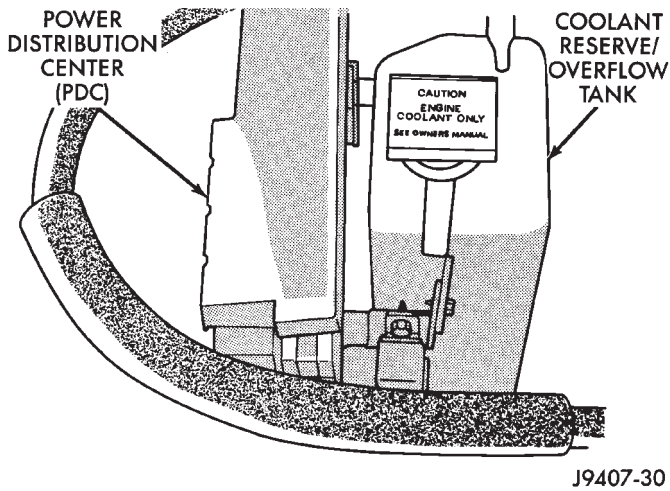

Fig. 4 PDC—XJ Models

(4) Inspect ignition coil connections. Verify that coil secondary cable is firmly connected to coil (Figs. 5 or 6).

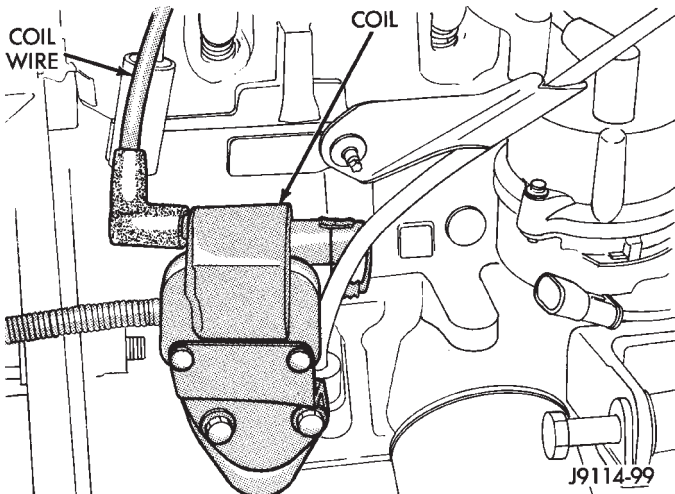

Fig. 5 Ignition Coil—2.5L Engine

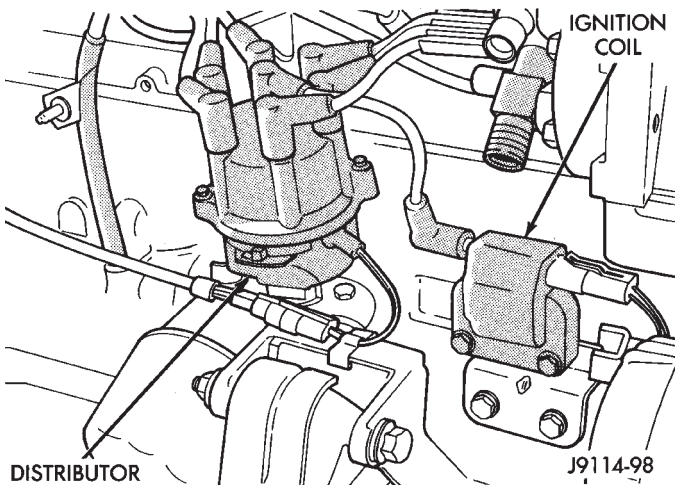

Fig. 6 Ignition Coil—4.0L Engine

(5) Verify that distributor cap is correctly attached to distributor. Be sure that spark plug cables are firmly connected to the distributor cap and the spark plugs in their correct firing order. Be sure that coil cable is firmly connected to distributor cap and coil. Be sure that camshaft position sensor wire connector is firmly connected to harness connector (Figs. 7 or 8). Inspect spark plug condition. Refer to Group 8D, Ignition System. Connect vehicle to an oscilloscope and inspect spark events for fouled or damaged spark plugs or cables.

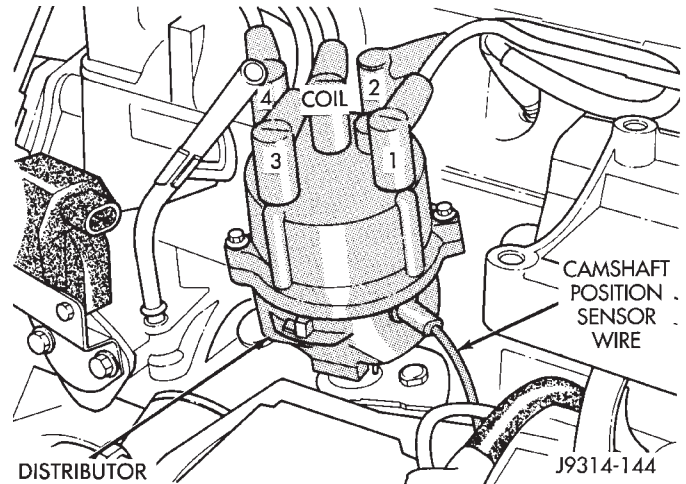

Fig. 7 Distributor and Wiring—2.5L Engine

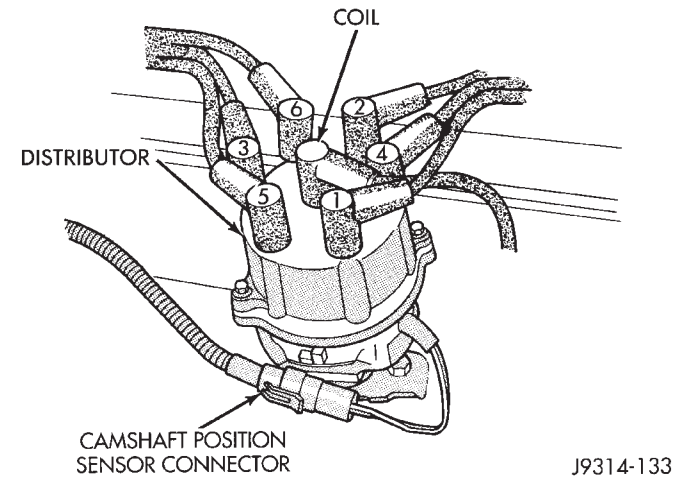

Fig. 8 Distributor and Wiring—4.0L Engine

(6) Verify that generator output wire, generator connector and ground wire are firmly connected to the generator (Fig. 9).

(7) Inspect the system ground connections at the cylinder block behind the engine oil dipstick tube (Fig. 10).

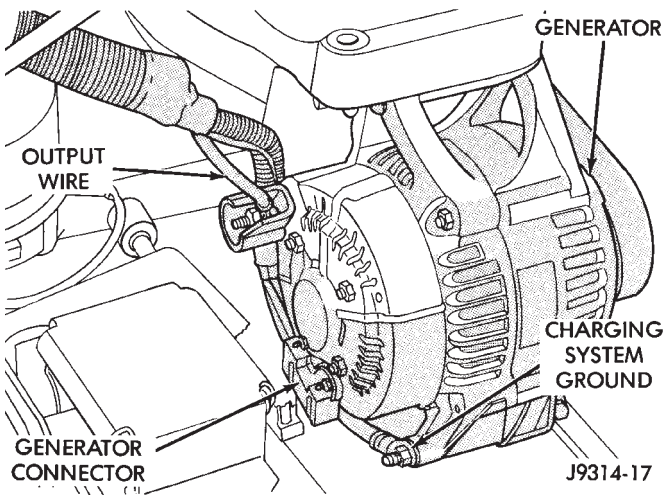

Fig. 9 Generator Connector and Output Wire Connections—Typical

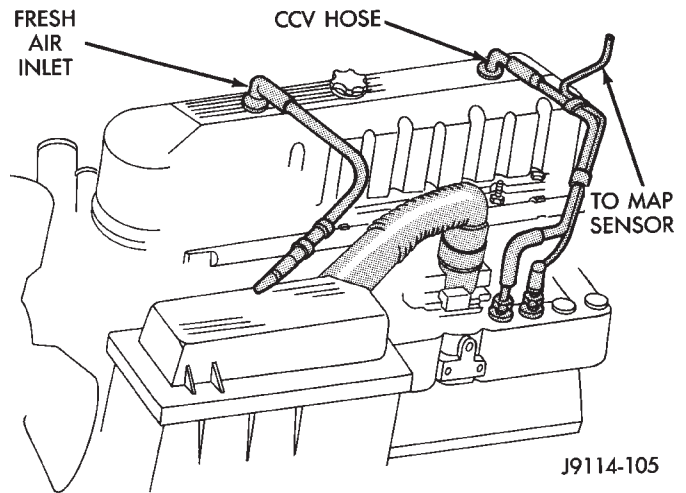

Fig. 12 CCV System—4.0L Engine

(9) Verify that vacuum hose is firmly connected to fuel pressure regulator and manifold fitting (Figs. 13 or 14).

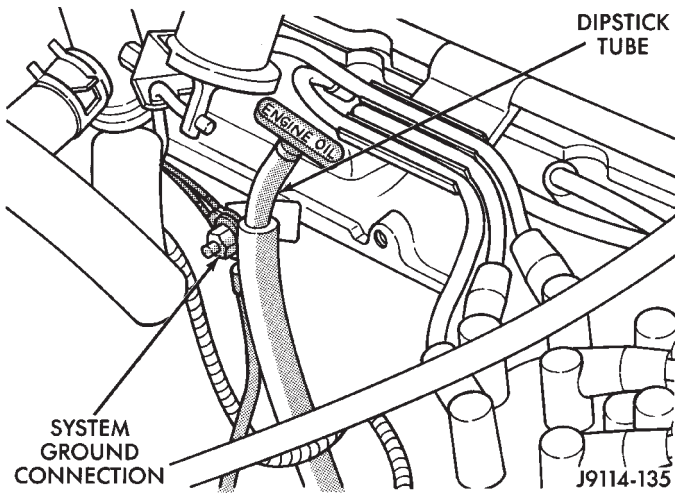

Fig. 10 System Ground Connections—Typical

(8) Verify that crankcase ventilation (CCV) fresh air hose is firmly connected to cylinder head and air cleaner covers (Figs. 11 or 12).

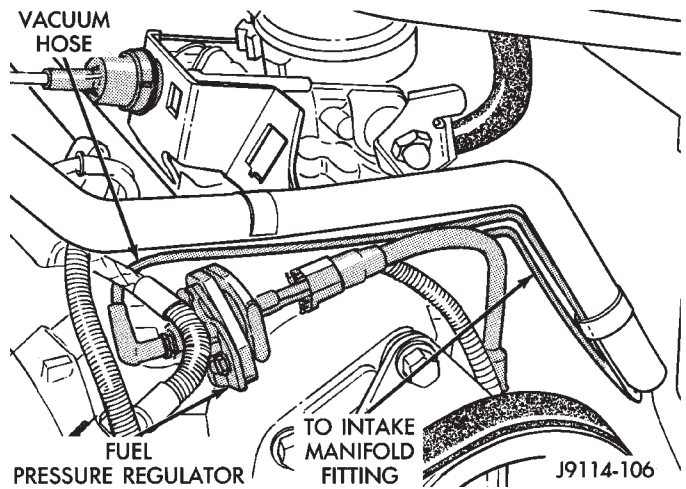

Fig. 13 Pressure Regulator Vacuum Hose—2.5L Engine

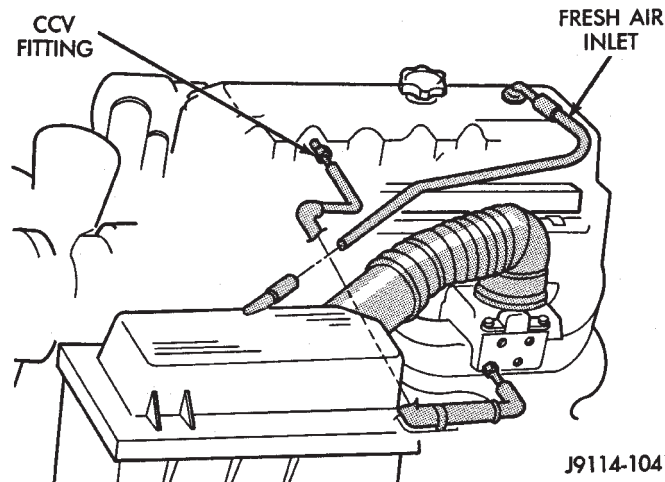

Fig. 11 CCV System—2.5L Engine

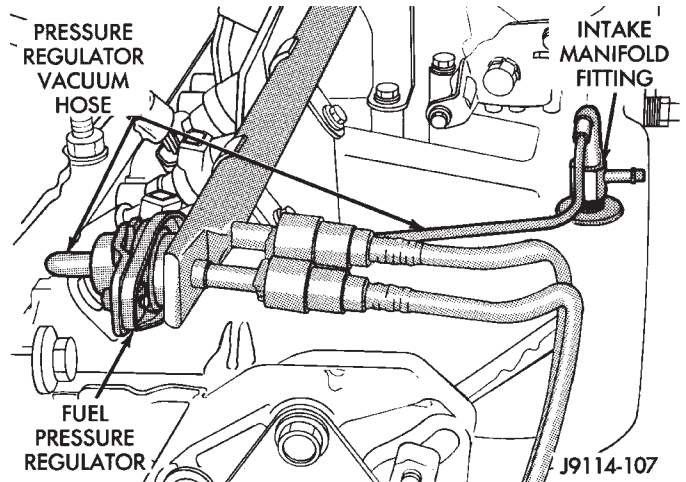

Fig. 14 Pressure Regulator Vacuum Hose—4.0L Engine

(10) Inspect fuel tube quick-connect fitting-to-fuel rail connections (Fig. 15).

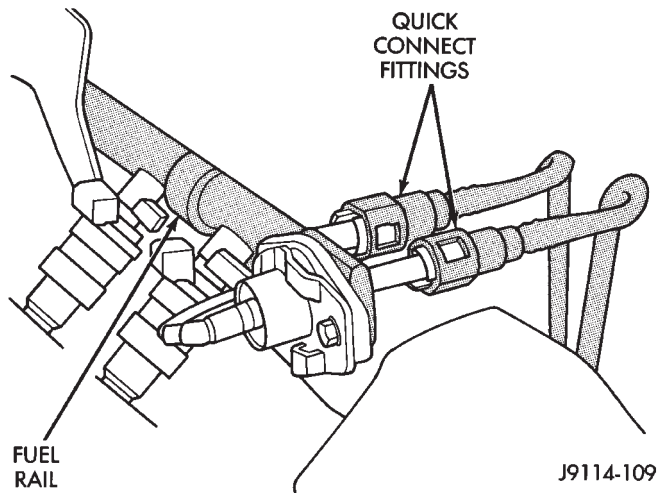

Fig. 15 Fuel Supply Tube—Typical

(11) Verify that hose connections to all ports of vacuum fittings on intake manifold are tight and not leaking.

(12) Inspect accelerator cable, transmission throttle cable (if equipped) and cruise control cable connections (if equipped). Check their connections to the throttle arm of throttle body for any binding or restrictions (Fig. 16).

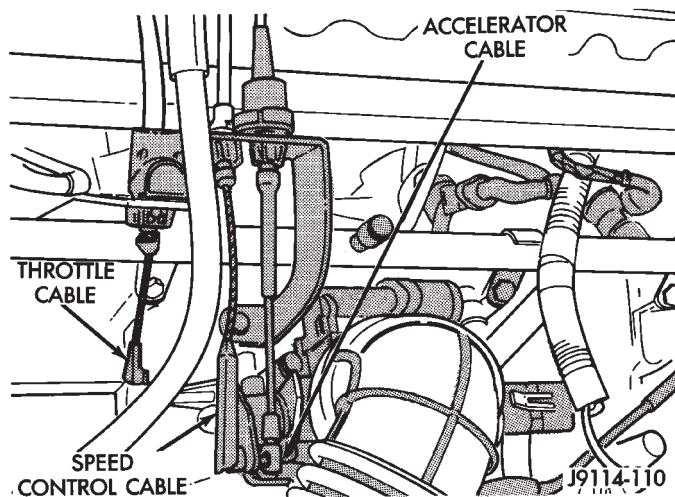

Fig. 16 Throttle Body Cables—Typical

(13) If equipped with vacuum brake booster, verify that vacuum booster hose is firmly connected to fitting on intake manifold. Also check connection to brake vacuum booster (Fig. 17).

(14) On XJ models equipped with 4.0L engine and A/C, verify that auxiliary cooling fan wire connector is firmly connected to harness (Fig. 18).

(15) Inspect the air cleaner inlet and air filter element for restrictions.

(16) Inspect radiator grille area, radiator fins and air conditioning condenser for restrictions.

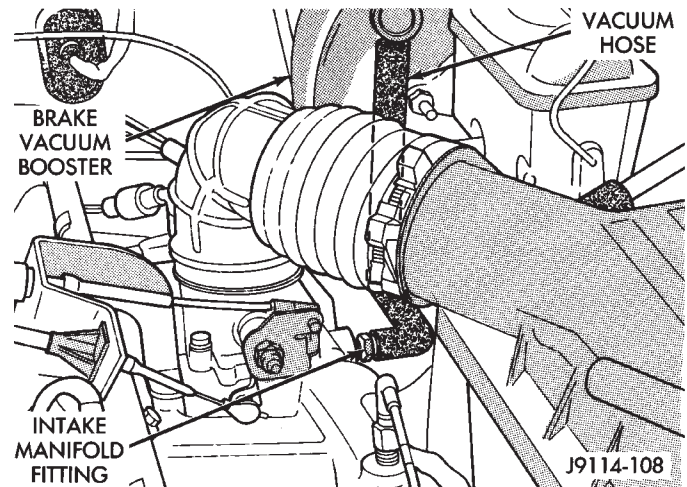

Fig. 17 Brake Vacuum Booster Hose—Typical

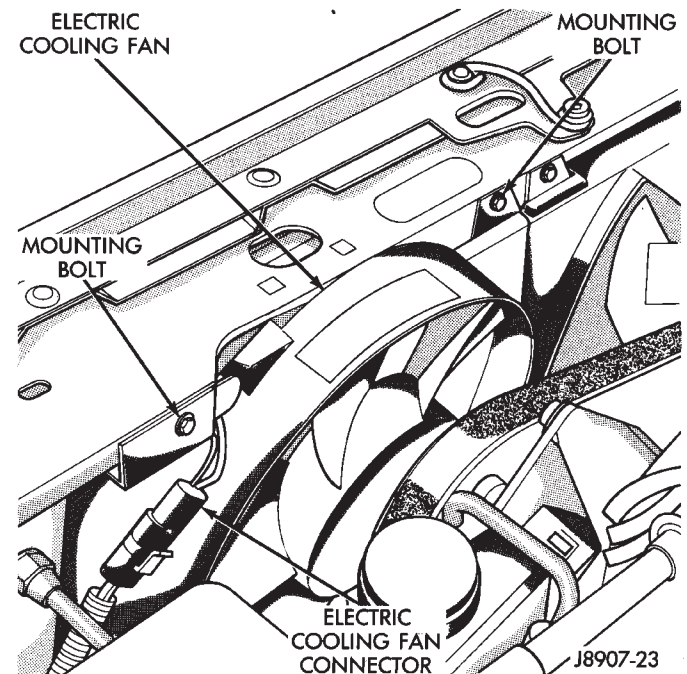

Fig. 18 Auxiliary Cooling Fan Connector—XJ with 4.0L Engine

(17) Verify that intake manifold air temperature sensor wire connector is firmly connected to harness connector (Figs. 19 or 20).

(18) Inspect engine ground strap connections at dash panel and rear cylinder head bolt (Fig. 21).

(19) Verify that MAP sensor electrical connector is firmly connected to MAP sensor (Fig. 22). Verify that vacuum hose is firmly connected to MAP sensor and to the intake manifold.

(20) Verify that fuel injector wire harness connectors are firmly connected to the fuel injectors in the correct order. Each harness connector is tagged with the number of its corresponding fuel injector (Fig. 23).

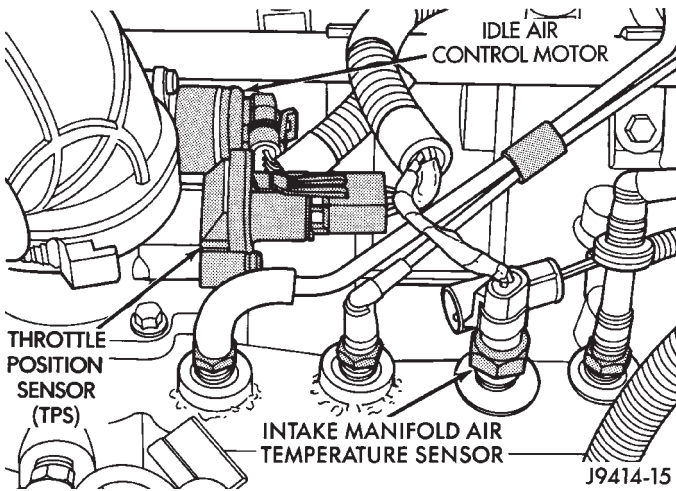

Fig. 19 Sensor Location—4.0L Engine

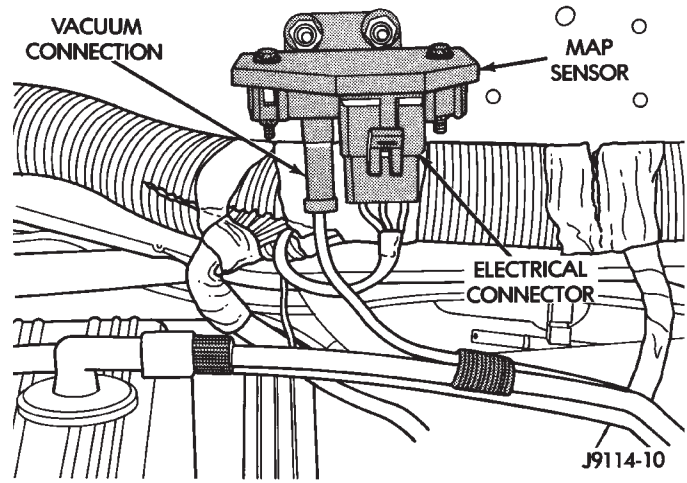

Fig. 22 MAP Sensor—Typical

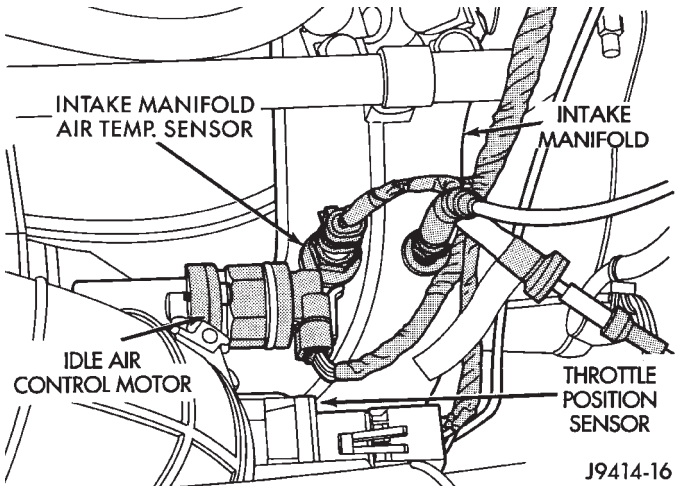

Fig. 20 Sensor Location—2.5L Engine

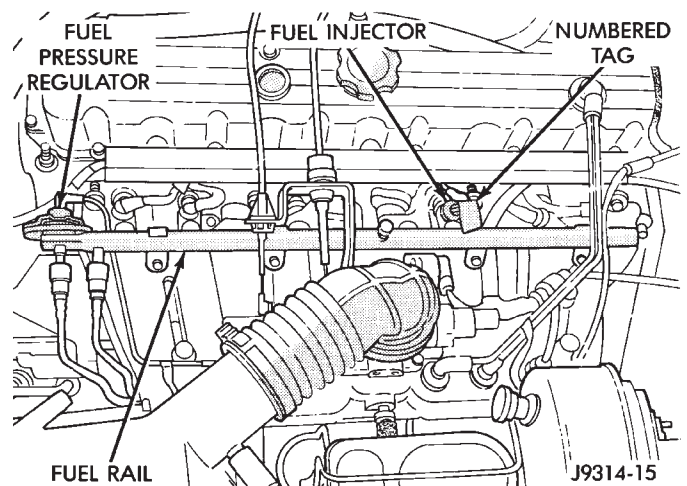

Fig. 23 Fuel Injector Wire Harness—Typical

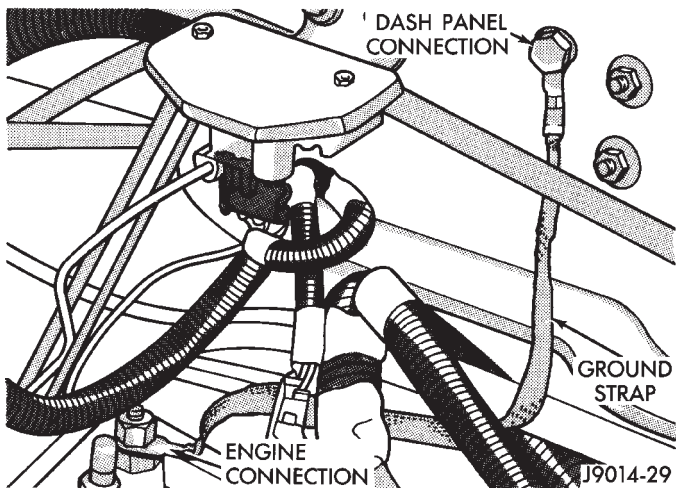

Fig. 21 Engine Ground Strap Connections—Typical

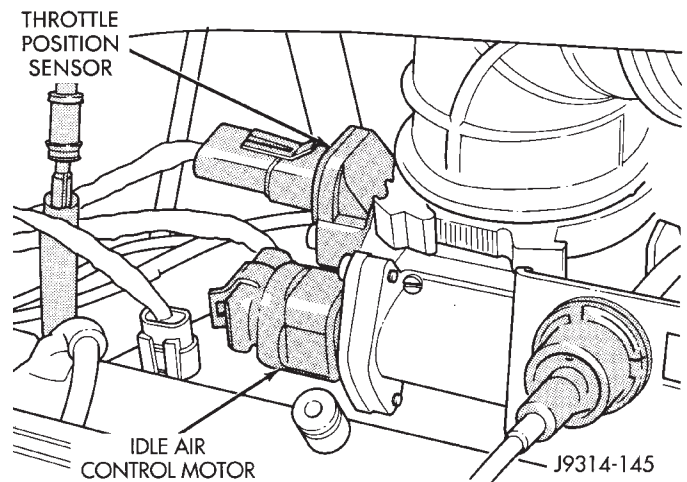

Fig. 24 IAC Motor and TPS—2.5L Engine

(21) Verify that harness connectors are firmly connected to idle air control (IAC) motor and throttle position sensor (TPS) (Figs. 19, 20 or 24).

(22) Verify that wire harness connector is firmly connected to the coolant temperature sensor (Fig. 25).

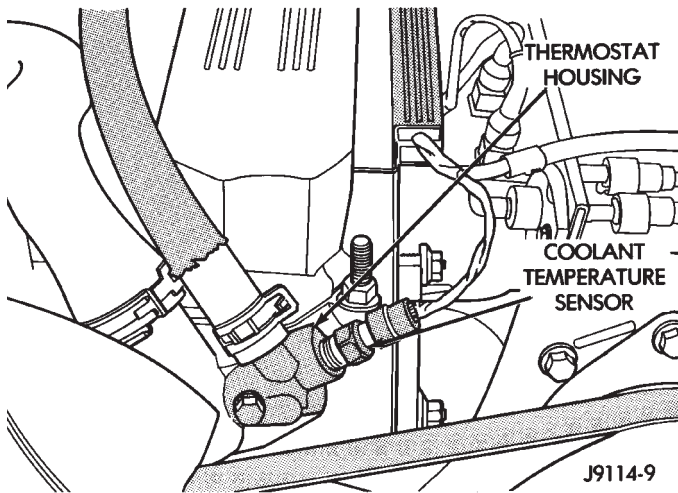

Fig. 25 Coolant Temperature Sensor—Typical

(23) Verify that oxygen sensor wire connector is firmly connected to the sensor. Inspect sensor and connector for damage (Fig. 26).

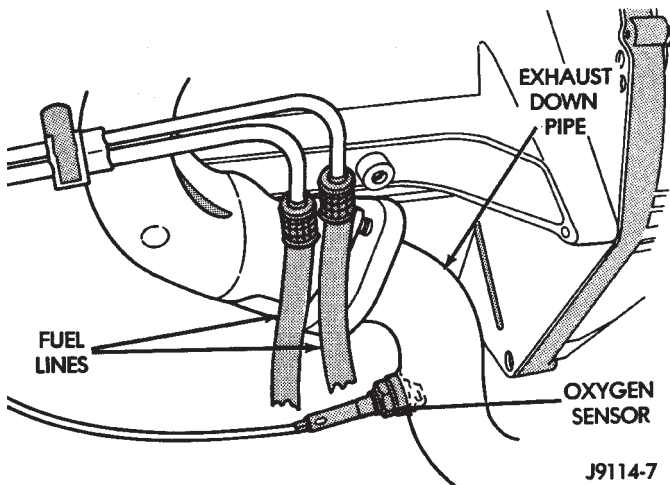

Fig. 26 Oxygen Sensor Location—Typical

(24) Raise and support the vehicle.

(25) Inspect for pinched or leaking fuel tubes. Inspect for pinched cracked or leaking fuel hoses.

(26) Inspect for exhaust system restrictions such as pinched exhaust pipes, collapsed muffler or plugged catalytic converter.

(27) If equipped with automatic transmission, verify that electrical harness is firmly connected to park/neutral safety switch. Refer to Automatic Transmission section of Group 21.

(28) Verify that the harness connector is firmly connected to the vehicle speed sensor (Fig. 27).

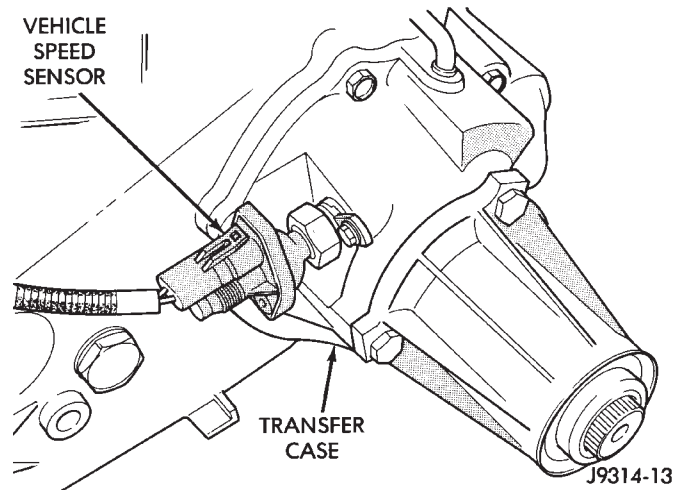

Fig. 27 Vehicle Speed Sensor—Typical

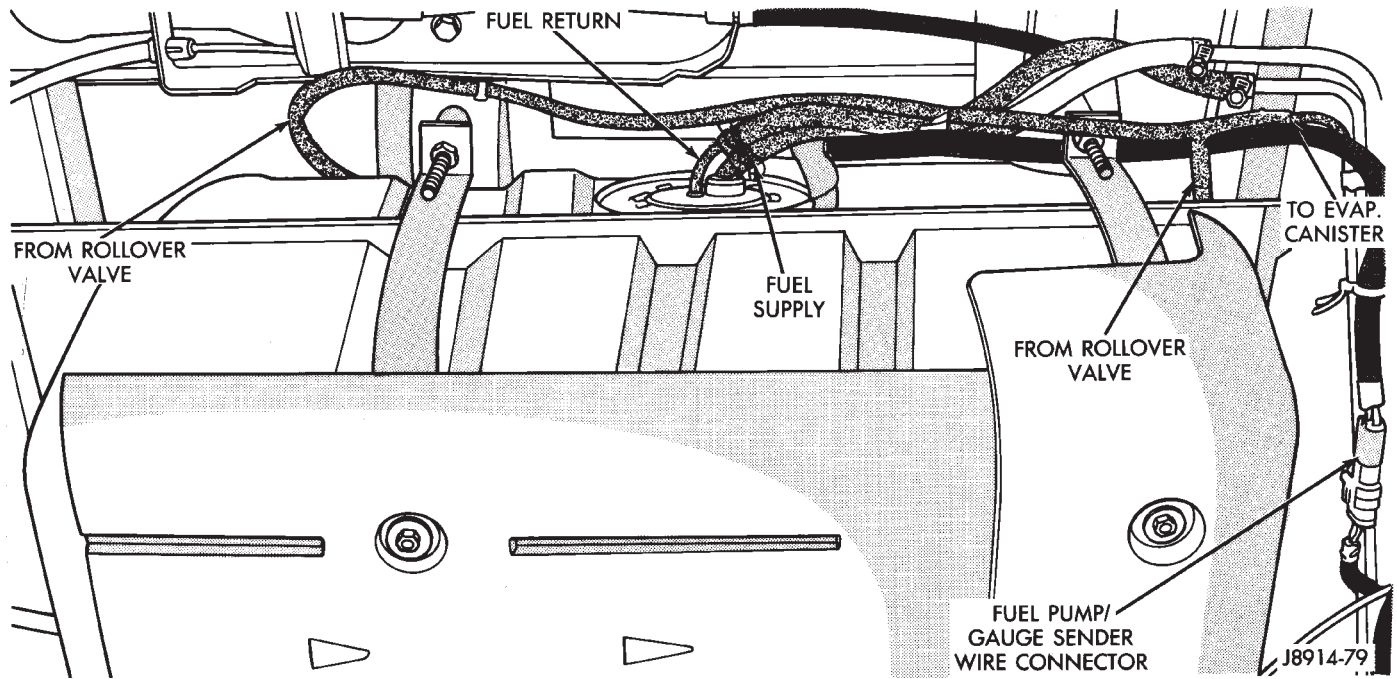

Fig. 28 Fuel Pump Module Connector and Fuel Hoses—Typical

(29) Verify that fuel pump module wire connector is firmly connected to harness connector.

(30) Inspect fuel hoses at fuel pump module for cracks or leaks (Fig. 28).

(31) Inspect transmission torque convertor housing (automatic transmission) or clutch housing (manual transmission) for damage to timing ring on drive plate/flywheel.

(32) Verify that battery cable and solenoid feed wire connections to the starter solenoid are tight and clean. Inspect for chaffed wires or wires rubbing up against other components (Fig. 29).

POWERTRAIN CONTROL MODULE (PCM) 60-WAY CONNECTOR

For PCM 60-way connector wiring schematics, refer to Group 8W, Wiring Diagrams.

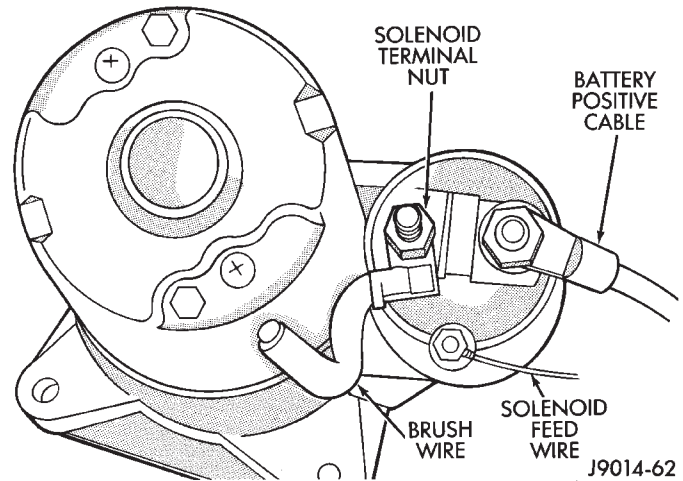

Fig. 29 Starter Solenoid Connections—Typical

SYSTEM SCHEMATICS

Fuel system schematics for the 2.5L 4 cylinder and 4.0L 6 cylinder engines are shown in figures 30, 31, 32 and 33.

J9414-19

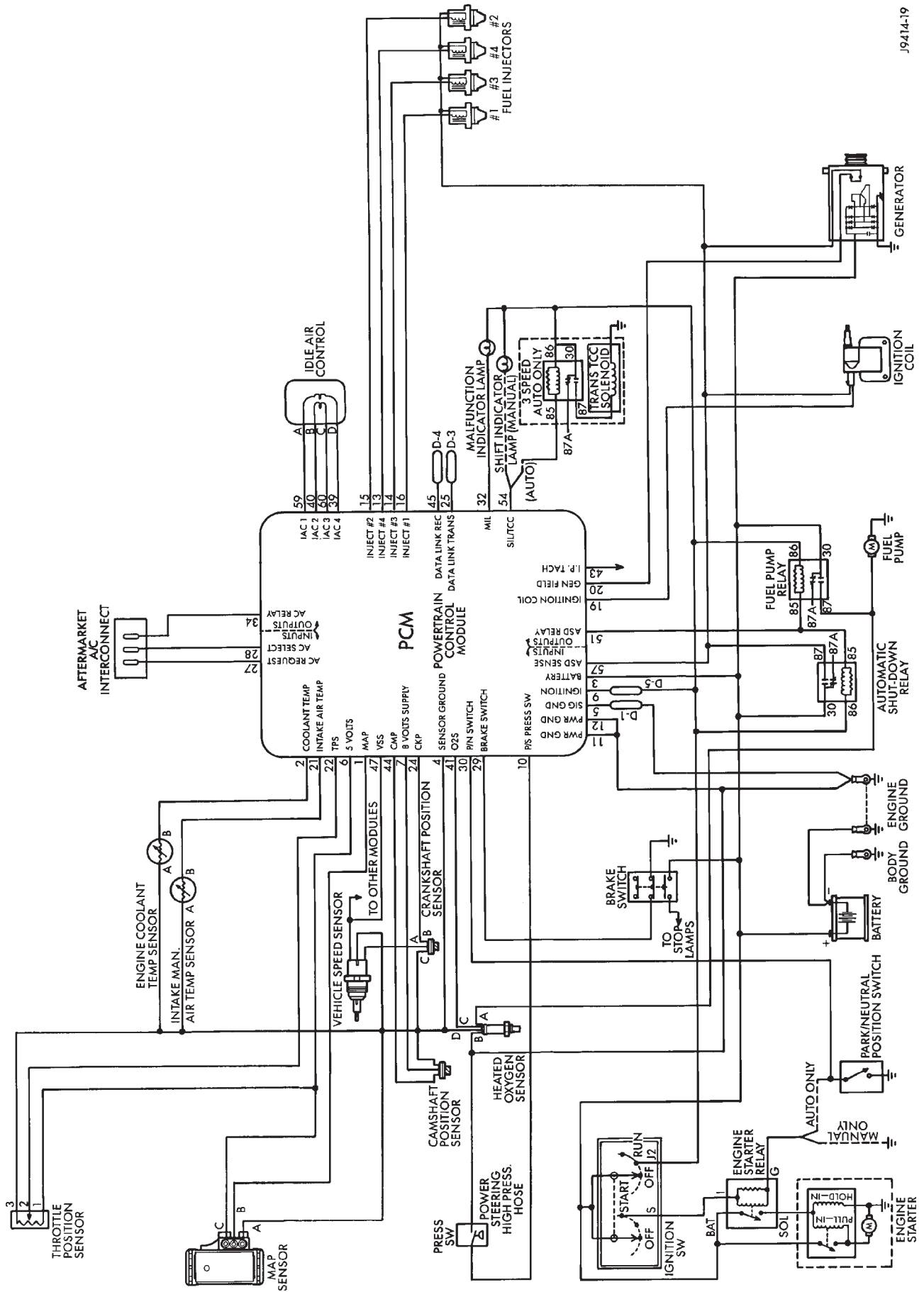

Fig. 30 System Schematic—YJ Models with 2.5L Engine

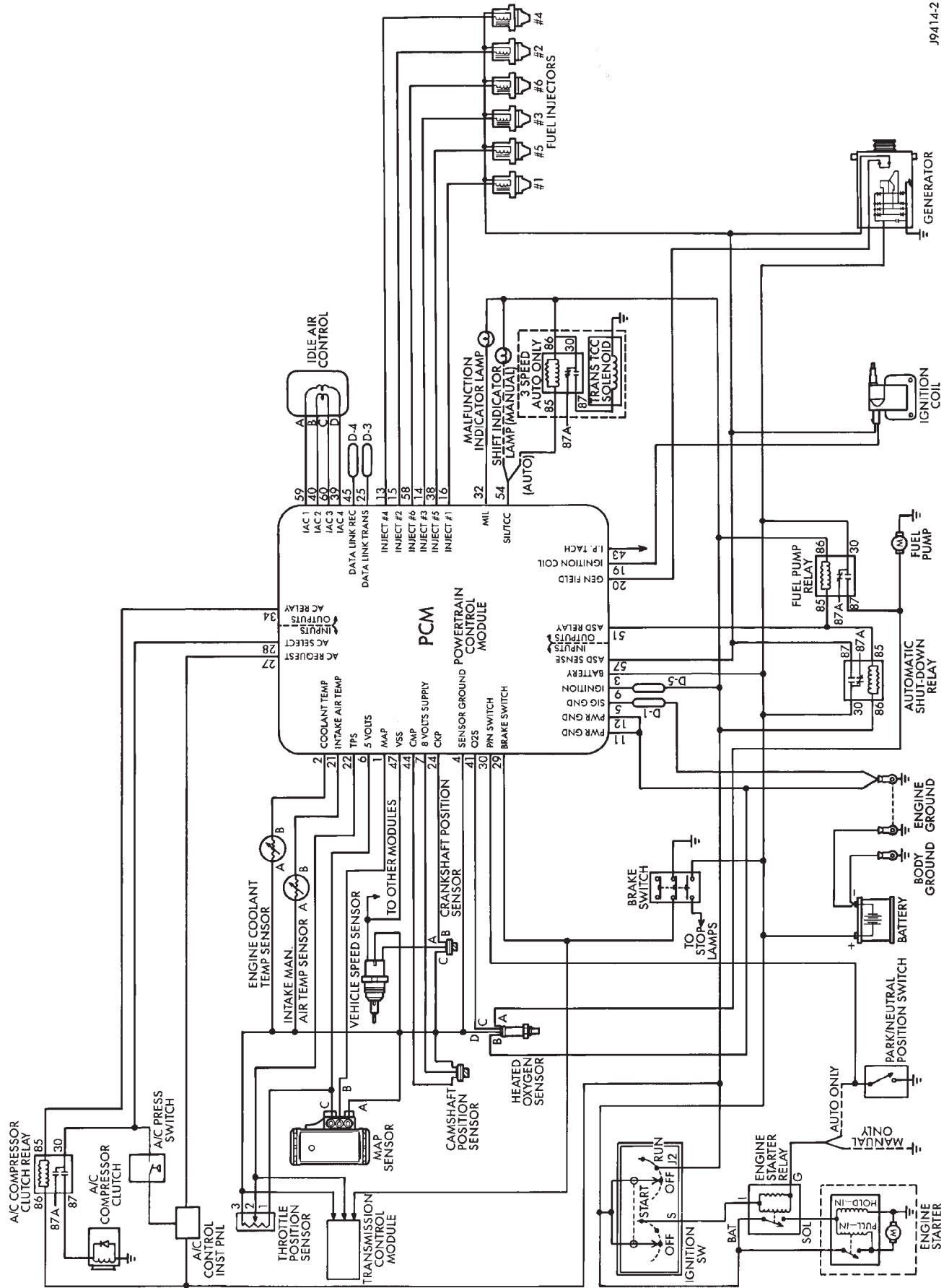
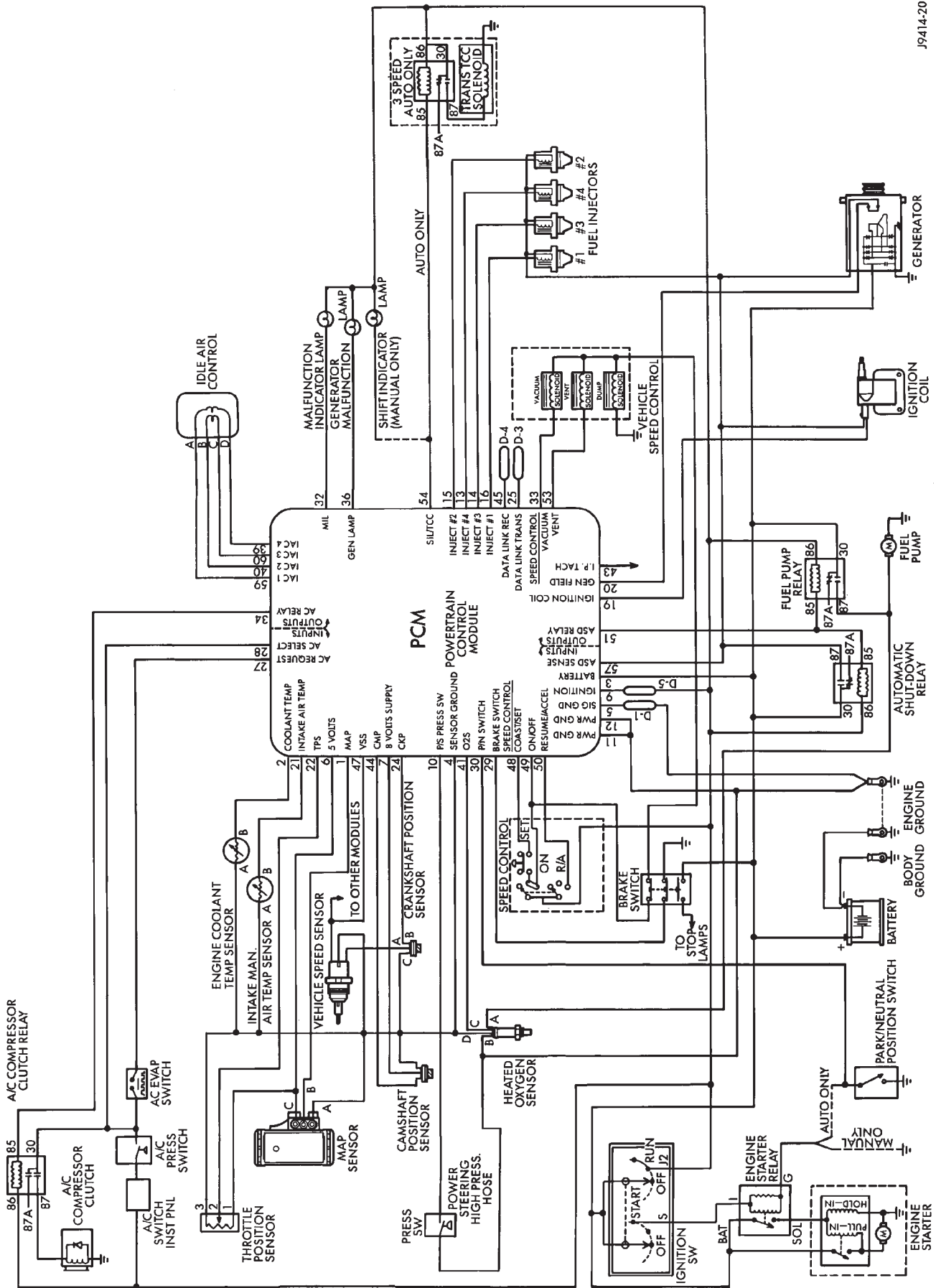
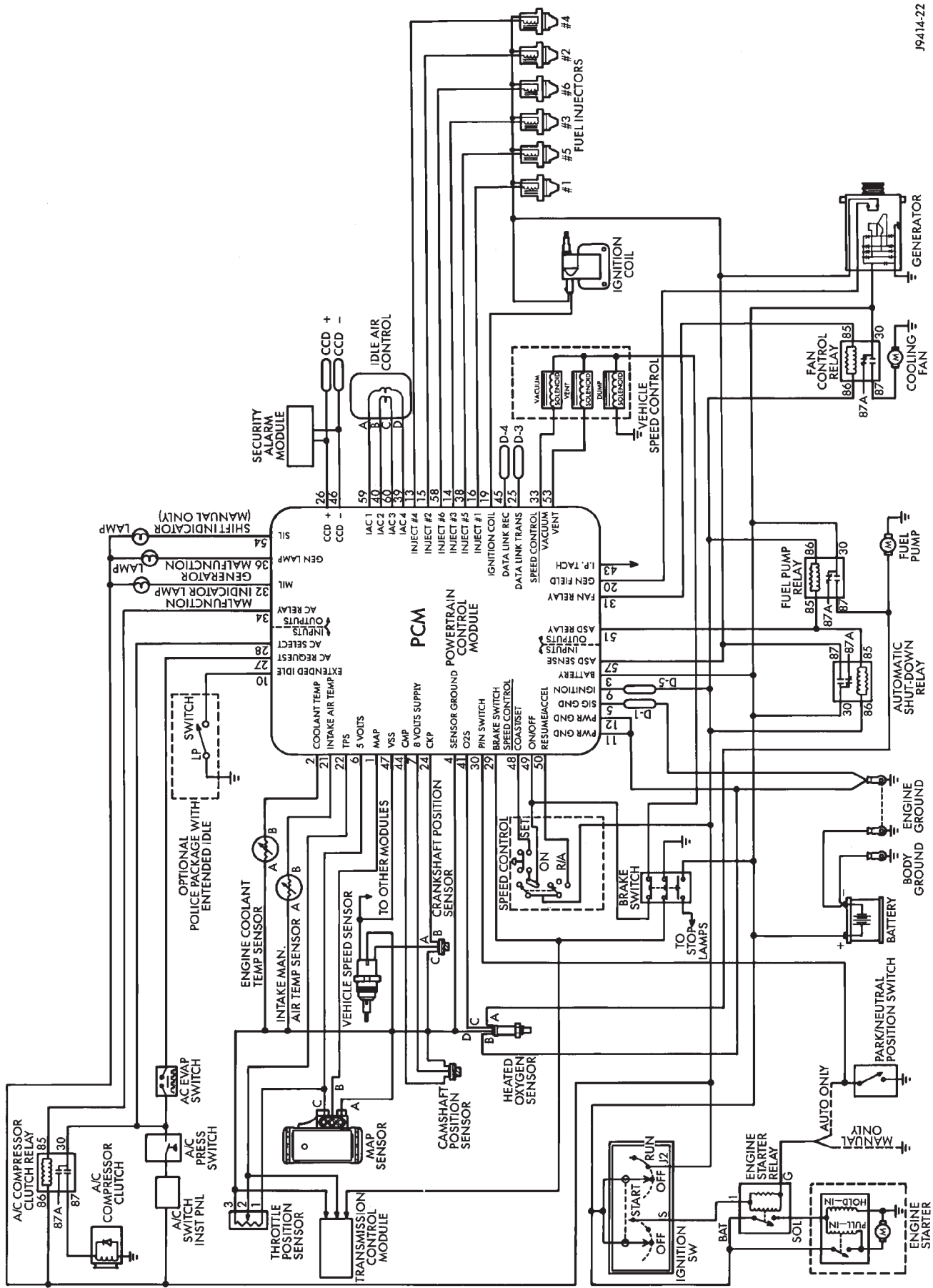

Fig. 31 System Schematic—YJ Models with 4.0L Engine



J9414-20

Fig. 32 System Schematic—XJ Models with 2.5L Engine



J9414-22

Fig. 33 System Schematic—XJ Models with 4.0L Engine

AUTOMATIC SHUT DOWN (ASD) RELAY TESTING

To perform a complete test of the ASD relay and its circuitry, refer to the DRB scan tool and appropriate Powertrain Diagnostics Procedures manual. To test the relay only, refer to Relays—Operation/Testing in this section of the group.

CAMSHAFT POSITION SENSOR TEST

Refer to Group 8D, Ignition Systems, for Camshaft Position Sensor testing.

ENGINE COOLANT TEMPERATURE SENSOR TEST

To perform a complete test of the engine coolant temperature sensor and its circuitry, refer to DRB scan tool and appropriate Powertrain Diagnostics Procedures manual. To test the sensor only, refer to the following:

Disconnect wire harness connector from engine coolant temperature sensor (Fig. 34).

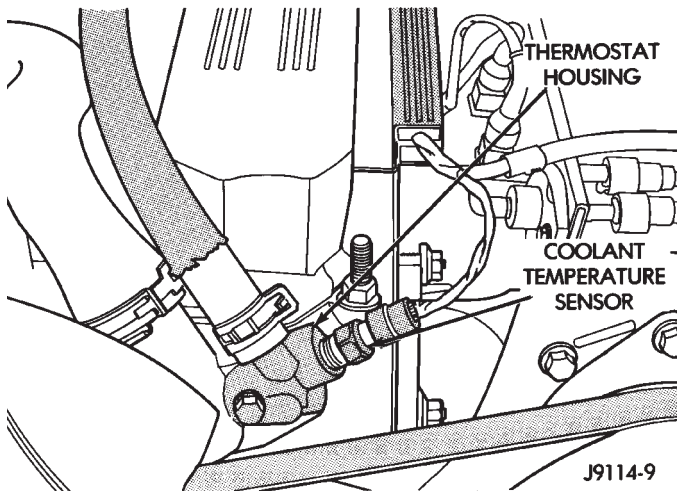

Fig. 34 Coolant Temperature Sensor—Typical

Test the resistance of the sensor with a high input impedance (digital) volt-ohmmeter. The resistance should be less than 1000 ohms with the engine at its correct operating temperature. Refer to the Coolant Temperature Sensor/Manifold Air Temperature Sensor resistance chart. Replace the sensor if it is not within the range of resistance specified in the chart.

Test continuity of the wire harness. Do this between the Powertrain Control Module (PCM) wire harness connector terminal-2 and the sensor connector terminal. Also test continuity of wire harness terminal-4 to the sensor connector terminal. Repair the wire harness if an open circuit is indicated.

INTAKE AIR TEMPERATURE SENSOR TEST

To perform a complete test of the sensor and its circuitry, refer to DRB scan tool and appropriate Powertrain Diagnostics Procedures manual. To test the sensor only, refer to the following:

SENSOR RESISTANCE (OHMS)—COOLANT TEMPERATURE SENSOR/MANIFOLD AIR TEMPERATURE

TEMPERATURE		RESISTANCE (OHMS)	
C	F	MIN	MAX
-40	-40	291,490	381,710
-20	-4	85,850	108,390
-10	14	49,250	61,430
0	32	29,330	35,990
10	50	17,990	21,810
20	68	11,370	13,610
25	77	9,120	10,880
30	86	7,370	8,750
40	104	4,900	5,750
50	122	3,330	3,880
60	140	2,310	2,670
70	158	1,630	1,870
80	176	1,170	1,340
90	194	860	970
100	212	640	720
110	230	480	540
120	248	370	410

J928D-4

Disconnect the wire harness connector from the intake manifold air temperature sensor (Figs. 35 or 36).

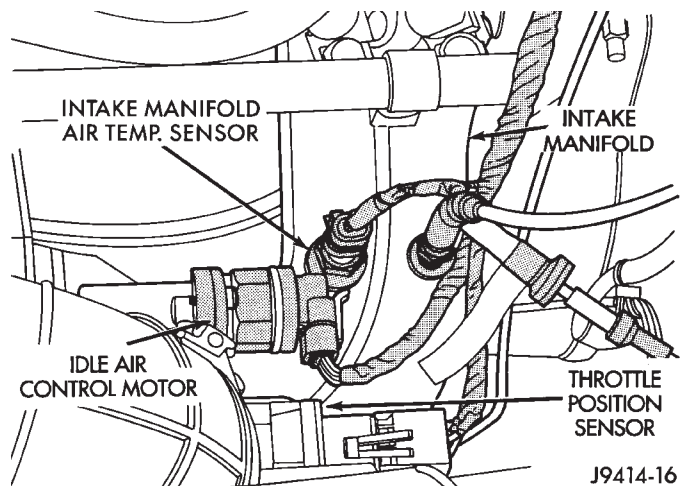

Fig. 35 Air Temperature Sensor—2.5L Engine

Test the resistance of the sensor with an input impedance (digital) volt-ohmmeter. The resistance should be less than 4000 ohms with the engine at operating temperature. The longer the engine idles, the warmer the intake manifold temperature will become. Refer to the Coolant Temperature Sensor/Manifold Air Temperature Sensor resistance chart. Replace the sensor if it is not within the range of resistance specified in the chart.

Test the resistance of the wire harness. Do this between the Powertrain Control Module (PCM) wire

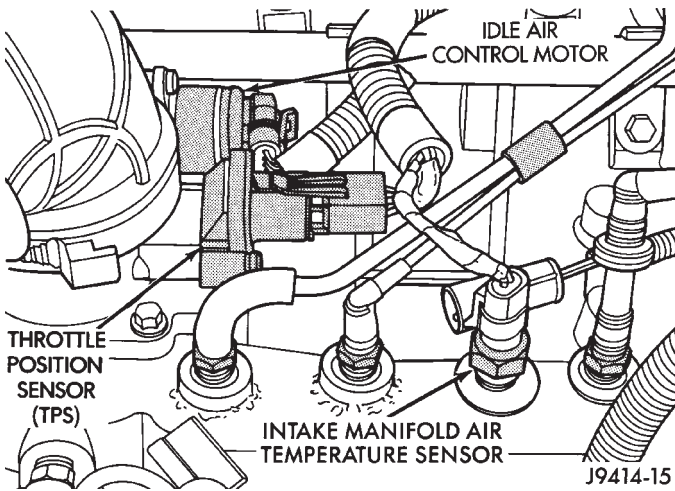

Fig. 36 Air Temperature Sensor—4.0L Engine

harness connector terminal-2 and the sensor connector terminal. Also test terminal-4 to the sensor connector terminal. Repair the wire harness as necessary if the resistance is greater than 1 ohm.

FUEL PUMP RELAY TESTING

For testing this relay, refer to Relays—Operation/Testing in this section of the group.

MANIFOLD ABSOLUTE PRESSURE (MAP) SENSOR TEST

To perform a complete test of the MAP sensor and its circuitry, refer to DRB scan tool and appropriate Powertrain Diagnostics Procedures manual. To test the sensor only, refer to the following:

Inspect the MAP sensor vacuum hose connections at the throttle body and sensor. Repair as necessary.

CAUTION: When testing, do not remove the electrical connector from MAP sensor (Fig. 37). Be sure that the MAP sensor harness wires are not damaged by the test meter probes.

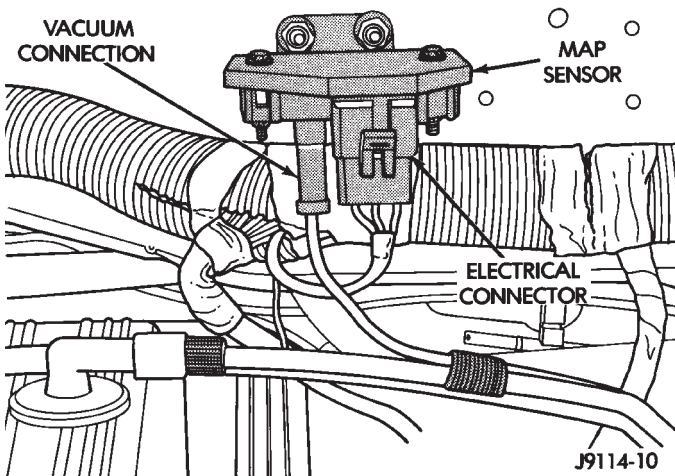
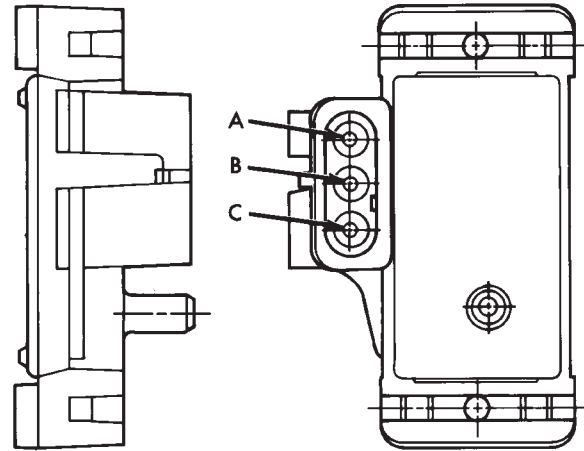

Fig. 37 MAP Sensor—Typical

Test the MAP sensor output voltage at the MAP sensor connector between terminals A and B (as marked on the sensor body) (Fig. 38). With the ignition switch ON and the engine OFF, output voltage should be 4-to-5 volts. The voltage should drop to 1.5-to-2.1 volts with a neutral-hot idle speed condition.



- A. Ground
- B. Output Voltage
- C. 5 Volts

J8914-91

Fig. 38 MAP Sensor Connector Terminals—Typical

Test Powertrain Control Module (PCM) (terminal-5) for the same voltage described above to verify the wire harness condition. Repair as necessary.

Test MAP sensor supply voltage at sensor connector between terminals A and C (Fig. 38) with the ignition ON and engine OFF. The voltage should be approximately 5 volts ($\pm 0.5V$). Five volts ($\pm 0.5V$) should also be at terminal-6 of the PCM wire harness connector. Repair or replace the wire harness as necessary.

Test the MAP sensor ground circuit at sensor connector terminal-A (Fig. 38) and PCM connector terminal-4. Repair the wire harness if necessary.

Test the MAP sensor ground circuit at the PCM connector between terminal-4 and terminal-11 with an ohmmeter. If the ohmmeter indicates an open circuit, inspect for a defective sensor ground connection. Refer to Group 8W, Wiring for location of engine grounds. If the ground connection is good, replace the PCM. If terminal-4 has a short circuit to 12 volts, correct this condition before replacing the PCM.

CRANKSHAFT POSITION SENSOR TEST

Refer to Group 8D, Ignition Systems for test procedures.

EXTENDED IDLE SWITCH TEST

OPTIONAL POLICE PACKAGE ONLY

OPERATION

The extended idle switch is used to raise the engine idle speed to approximately 1000 rpm when the shifter is in either the Park or Neutral position. A rocker-type 2-wire switch (extended idle switch) is mounted to the instrument panel. **This switch is available only with 4.0L engine when supplied with the optional police package.**

TESTING

The extended idle switch will control a ground circuit going to the powertrain control module (PCM). When a ground signal (through this switch) has been received at pin number 10 in the PCM, engine idle speed will increase.

Bring the engine to normal operating temperature and turn the extended idle switch to the ON position. Engine speed should now increase to approximately 1000 rpm when the shifter is in either the Park or Neutral position. If engine speed does not increase, apply a good ground to pin number 10 at the PCM using a small paper clip. Be careful not to damage the wiring with the paper clip. If the engine speed now increases, it can be assumed that the PCM is functioning correctly. Check the instrument panel mounted switch for a closed ground circuit when in the ON position. If the engine speed will not increase after applying a ground to pin number 10, replace the PCM. Refer to Group 8W, Wiring Diagrams for circuit and wiring information.

THROTTLE POSITION SENSOR (TPS) TEST

To perform a complete test of the sensor and its circuitry, refer to DRB scan tool and appropriate Powertrain Diagnostics Procedures manual. To test the sensor only, refer to the following:

The throttle position sensor (TPS) can be tested with a digital voltmeter. The center terminal of the TPS is the output terminal (Figs. 39 or 40).

With the ignition key in the ON position, back-probe the TPS connector. Check the TPS output voltage at the center terminal wire of the connector. Check this at idle (throttle plate closed) and at wide open throttle (WOT). At idle, TPS output voltage should be greater than 200 millivolts. At wide open throttle, TPS output voltage must be less than 4.8 volts. The output voltage should increase gradually as the throttle plate is slowly opened from idle to WOT.

TORQUE CONVERTER CLUTCH RELAY TEST

To test the relay only, refer to Relays—Operation/Testing in this section of the group. To test the torque converter clutch circuit and related compo-

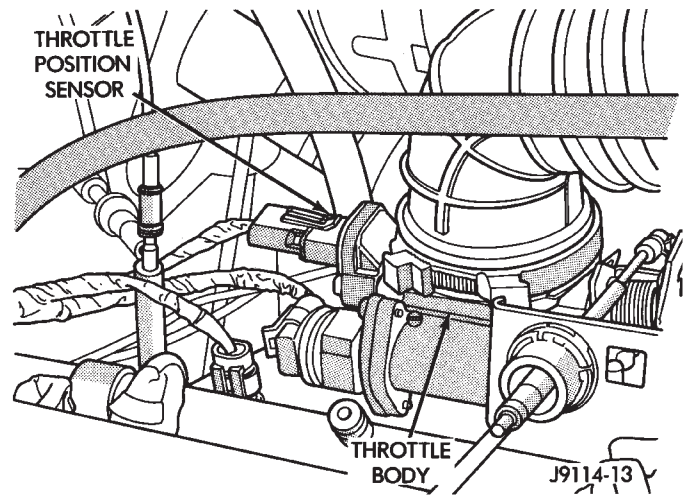

Fig. 39 TPS Testing—2.5L Engine

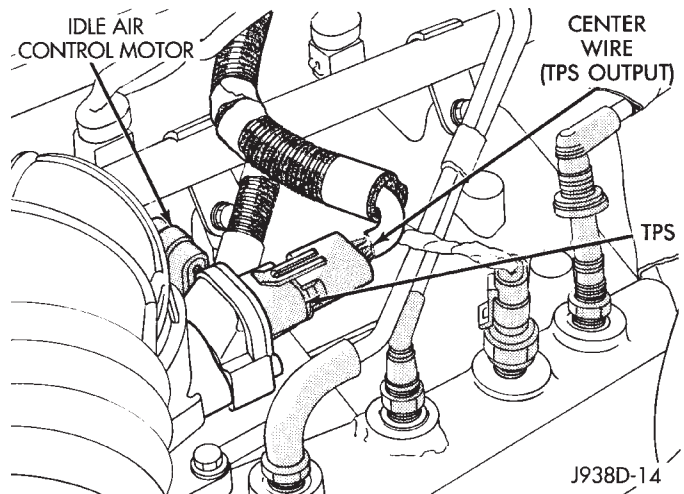

Fig. 40 TPS Testing—4.0L Engine

nents, refer to the appropriate Powertrain Diagnostic Procedures manual for operation of the DRB scan tool.

VEHICLE SPEED SENSOR TEST

To perform a complete test of the sensor and its circuitry, refer to DRB scan tool and appropriate Powertrain Diagnostics Procedures manual.

OXYGEN SENSOR (O2S) HEATING ELEMENT TEST

To perform a complete test of the O2S sensor (Fig. 41) and its circuitry, refer to DRB scan tool and appropriate Powertrain Diagnostics Procedures manual. To test the sensor only, refer to the following:

The oxygen sensor heating element can be tested with an ohmmeter as follows:

With the sensor at room temperature 25 degrees C (77 degrees F), disconnect the O2S sensor connector. Connect the ohmmeter test leads across the white wire terminals of the sensor connector. Resistance should be between 5 and 7 ohms. Replace the sensor if the ohmmeter displays an infinity (open) reading.

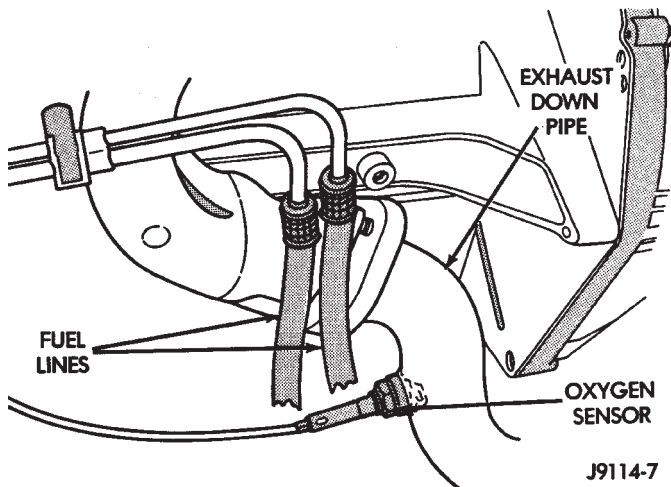

Fig. 41 Oxygen Sensor—Typical

IDLE AIR CONTROL MOTOR TEST

Idle Air Control (IAC) Motor operation can be tested using special exerciser tool number 7558 (Fig. 42).

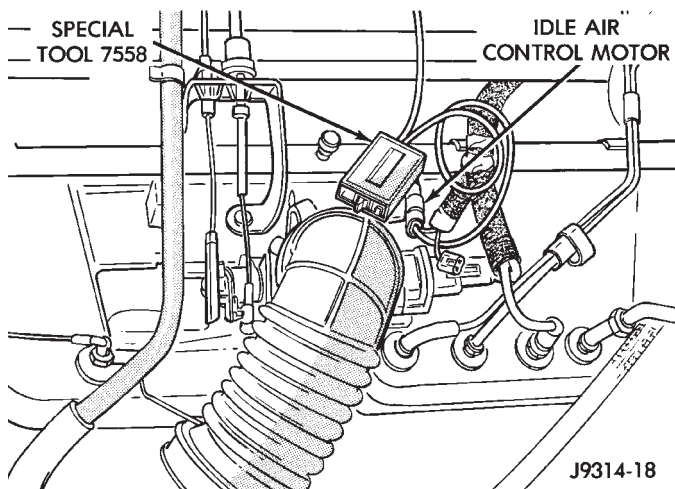

Fig. 42 IAC Motor Testing—Typical

CAUTION: Proper safety precautions must be taken when testing the idle air control motor:

- Set the parking brake and block the drive wheels
 - Route all tester cables away from the cooling fans, drive belt, pulleys and exhaust components
 - Provide proper ventilation while operating the engine
 - Always return the engine idle speed to normal before disconnecting the exerciser tool
- (1) With the ignition OFF, disconnect the IAC motor wire connector at throttle body (Fig. 42).
 - (2) Plug the exerciser tool number 7558 harness connector into the IAC motor.
 - (3) Connect the red clip of exerciser tool 7558 to battery positive terminal. Connect the black clip to

negative battery terminal. The red light on the exerciser tool will flash when the tool is properly connected.

(4) Start engine.

When the switch on the tool is in the HIGH or LOW position, the light on the tool will flash. This indicates that voltage pulses are being sent to the IAC stepper motor.

(5) Move the switch to the HIGH position. The engine speed should increase. Move the switch to the LOW position. The engine speed should decrease.

(a) If the engine speed changes while using the exerciser tool, the IAC motor is functioning properly. Disconnect the exerciser tool and connect the IAC motor wire connector to the stepper motor.

(b) If the engine speed does not change, turn the ignition OFF and proceed to step (6). Do not disconnect exerciser tool from the IAC motor.

(6) Remove the IAC motor from the throttle body. Do not remove IAC motor housing from throttle body.

CAUTION: When checking IAC motor operation with the motor removed from the throttle body, do not extend the pintle (Fig. 43) more than 6.35 mm (.250 in). If the pintle is extended more than this amount, it may separate from the IAC motor. The IAC motor must be replaced if the pintle separates from the motor.

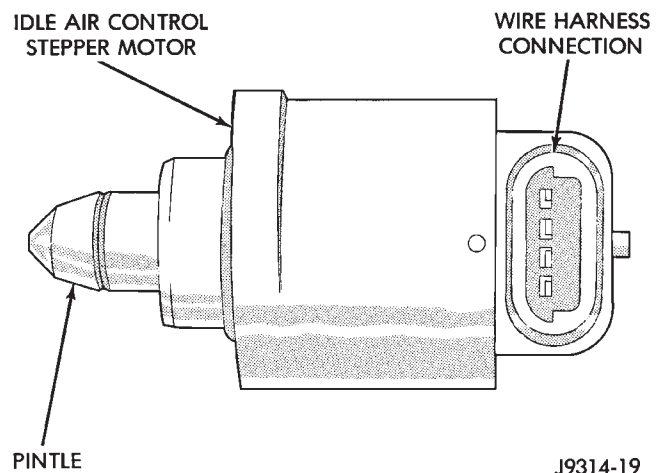

Fig. 43 Idle Air Control (IAC) Motor Pintle

(7) With the ignition OFF, cycle the exerciser tool switch between the HIGH and LOW positions. Observe the pintle. The pintle should move in-and-out of the motor.

(a) If the pintle does not move, replace the idle air control motor. Start the engine and test the replacement motor operation as described in step (5).

(b) If the pintle operates properly, check the idle air control motor bore in the throttle body bore for blockage and clean as necessary. Reinstall the idle air control motor and retest. If blockage is not

found, refer to the DRB scan tool and the appropriate Powertrain Diagnostics Procedures service manual.

RELAYS—OPERATION/TESTING

OPERATION

The following operations/tests apply to these relays only: automatic shut down (ASD), fuel pump and torque converter clutch. For operations/tests on all other relays, refer to the appropriate section of this service manual.

The relay terminal numbers from (Fig. 44) can be found on the bottom of the relay:

- Terminal number 30 is connected to battery voltage and can be switched or B+ (hot) at all times.
- Terminal number 87A is connected (a circuit is formed) to terminal 30 in the de-energized (normally OFF) position.
- Terminal number 87 is connected (a circuit is formed) to terminal 30 in the energized (ON) position. Terminal number 87 then supplies battery voltage to the component being operated.
- Terminal number 86 is connected to a switched (+) power source.
- Terminal number 85 is grounded by the powertrain control module (PCM).

TESTING

(1) Remove relay before testing.
 (2) Using an ohmmeter, perform a resistance test between terminals 85 and 86. Resistance value (ohms) should be 75 ± 5 ohms for resistor equipped relays.

(3) Connect the ohmmeter between terminals number 87A and 30. Continuity should be present at this time.

(4) Connect the ohmmeter between terminals number 87 and 30. Continuity should not be present at this time.

(5) Use a set of jumper wires (16 gauge or smaller). Connect one jumper wire between terminal number 85 (on the relay) to the ground side (-) of a 12 Volt power source.

(6) Attach the other jumper wire to the positive side (+) of a 12V power source. Do not connect the jumper wire to relay at this time.

CAUTION: DO NOT ALLOW THE OHMMETER TO CONTACT TERMINALS 85 OR 86 DURING THESE TESTS. DAMAGE TO OHMMETER MAY RESULT.

(7) Attach the other jumper wire (12V +) to terminal number 86. This will activate the relay. Continuity should now be present between terminals number

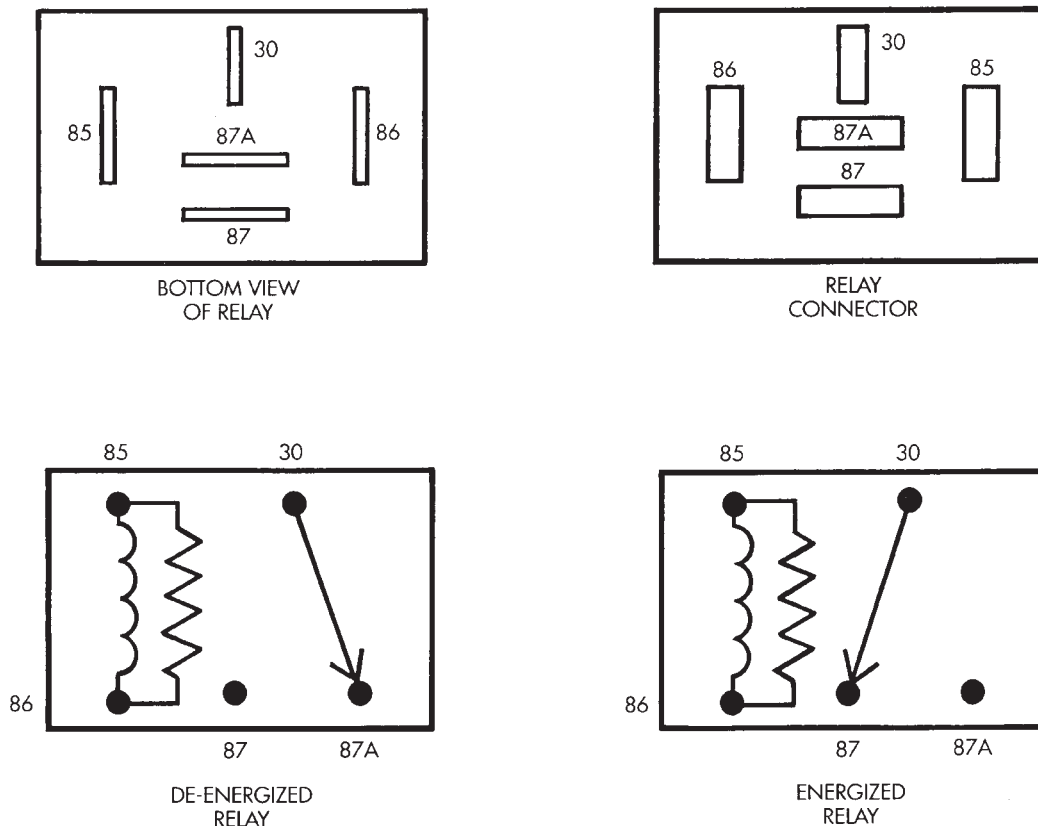

Fig. 44 Relay Terminals

87 and 30. Continuity should not be present between terminals number 87A and 30.

(8) Disconnect jumper wires from relay and 12 Volt power source.

If continuity or resistance tests did not pass, replace relay. If tests passed, refer to Group 8W, Wiring Diagrams for additional circuit information. Also refer to the appropriate Powertrain Diagnostic Procedures manual for operation of the DRB scan tool.

STARTER MOTOR RELAY TEST

Refer to Group 8A, Battery/Starting/Charging/System Diagnostics, for starter motor relay testing.

INJECTOR TEST

Disconnect the injector wire connector from the injector. Place an ohmmeter on the injector terminals. Resistance reading should be approximately 14.5 ohms \pm 1.2 ohms at 20°C (68°F). Proceed to following Injector Diagnosis chart.

FUEL SYSTEM PRESSURE TEST

Refer to the Fuel Delivery System section of this group. See Fuel System Pressure Test.

ON-BOARD DIAGNOSTICS (OBD)

The Powertrain Control Module (PCM) has been programmed to monitor many different circuits of the fuel injection system. If a problem is sensed in a monitored circuit often enough to indicate an actual problem, a Diagnostic Trouble Code (DTC) is stored. The DTC will be stored in the PCM memory for eventual display to the service technician. If the problem is repaired or ceases to exist, the PCM cancels the DTC after 51 engine starts.

Certain criteria must be met for a diagnostic trouble code (DTC) to be entered into PCM memory. The criteria may be a specific range of engine rpm, engine temperature and/or input voltage to the PCM.

It is possible that a DTC for a monitored circuit may not be entered into memory even though a malfunction has occurred. This may happen because one of the DTC criteria for the circuit has not been met. Example: assume that one of the criteria for the MAP sensor circuit is that the engine must be operating between 750 and 2000 rpm to be monitored for a DTC. If the MAP sensor output circuit shorts to ground when the engine rpm is above 2400 rpm, a 0 volt input will be seen by the PCM. A DTC will not be entered into memory because the condition does not occur within the specified rpm range.

A DTC indicates that the powertrain control module (PCM) has recognized an abnormal signal in a circuit or the system. A DTC may indicate the result of a failure, but never identify the failed component directly.

There are several operating conditions that the PCM does not monitor and set a DTC for. Refer to the following Monitored Circuits and Non-Monitored Circuits in this section.

MONITORED CIRCUITS

The powertrain control module (PCM) can detect certain problems in the fuel injection system.

Open or Shorted Circuit - The PCM can determine if sensor output (which is the input to PCM) is within proper range. It also determines if the circuit is open or shorted.

Output Device Current Flow - The PCM senses whether the output devices are hooked up.

If there is a problem with the circuit, the PCM senses whether the circuit is open, shorted to ground (-), or shorted to (+) voltage.

Oxygen Sensor - The PCM can determine if the oxygen sensor is switching between rich and lean. This is, once the system has entered Closed Loop. Refer to Open Loop/Closed Loop Modes Of Operation in the Component Description/System Operation section for an explanation of Closed (or Open) Loop operation.

NON-MONITORED CIRCUITS

The PCM does not monitor the following circuits, systems or conditions that could have malfunctions that result in driveability problems. A Diagnostic Trouble Code (DTC) may not be displayed for these conditions.

Fuel Pressure: Fuel pressure is controlled by the vacuum assisted fuel pressure regulator. The PCM cannot detect a clogged fuel pump inlet filter, clogged in-line fuel filter, or a pinched fuel supply or return line. However, these could result in a rich or lean condition causing an oxygen sensor DTC to be stored in the PCM.

Secondary Ignition Circuit: The PCM cannot detect an inoperative ignition coil, fouled or worn spark plugs, ignition cross firing, or open circuited spark plug cables.

Engine Timing: The PCM cannot detect an incorrectly indexed timing chain, camshaft sprocket or crankshaft sprocket. The PCM also cannot detect an incorrectly indexed distributor. However, these could result in a rich or lean condition causing an oxygen sensor DTC to be stored in the PCM.

Cylinder Compression: The PCM cannot detect uneven, low, or high engine cylinder compression.

Exhaust System: The PCM cannot detect a plugged, restricted or leaking exhaust system.

Fuel Injector Malfunctions: The PCM cannot determine if the fuel injector is clogged, or the wrong injector is installed. However, these could result in a rich or lean condition causing an oxygen sensor DTC to be stored in the PCM.

INJECTOR DIAGNOSIS—VEHICLE RUNS ROUGH AND/OR HAS A MISS

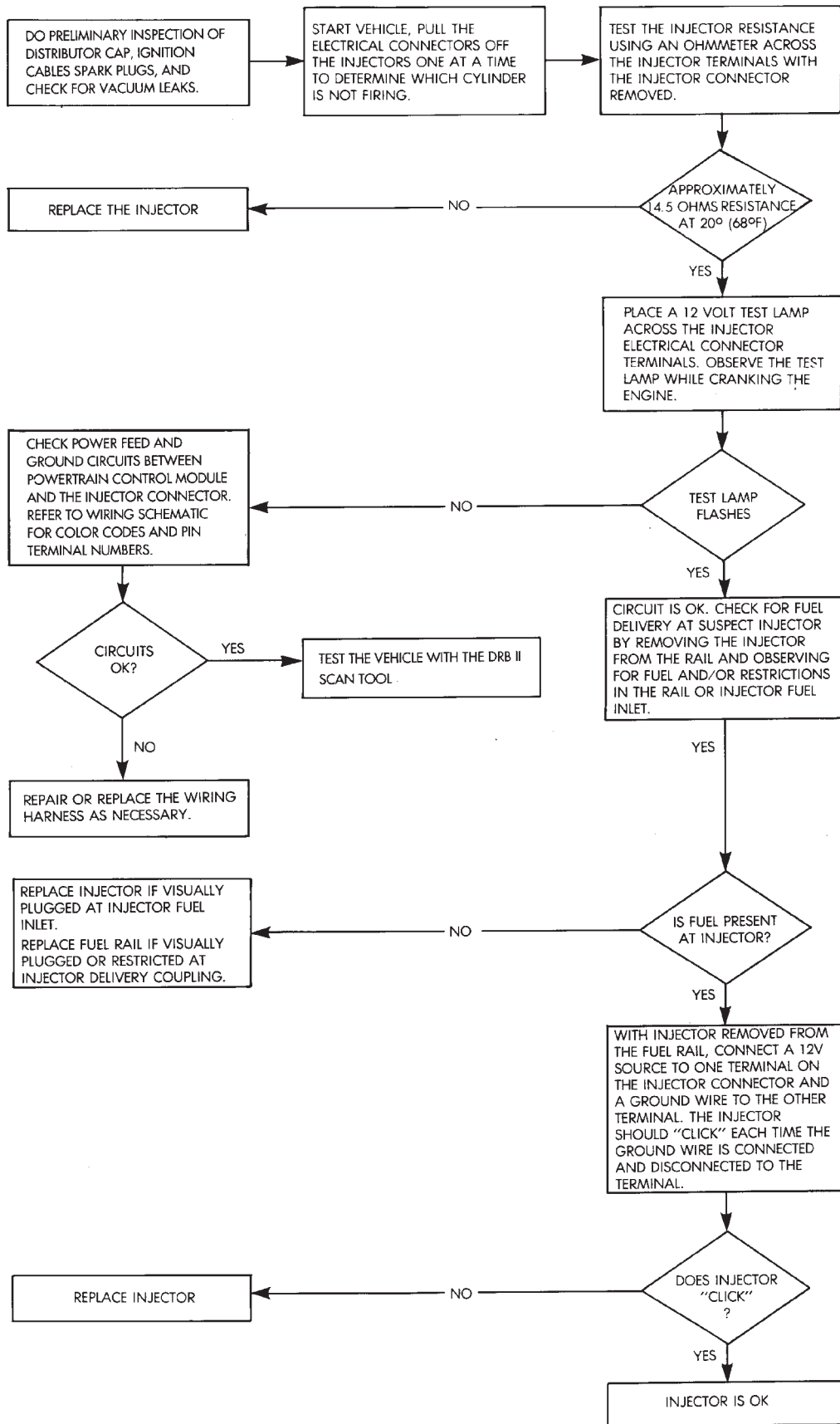

Excessive Oil Consumption: Although the PCM monitors exhaust stream oxygen content through oxygen sensor (closed loop), it cannot determine excessive oil consumption.

Throttle Body Air Flow: The PCM cannot detect a clogged or restricted air cleaner inlet or air filter element.

Evaporative System: The PCM will not detect a restricted, plugged or loaded EVAP canister.

Vacuum Assist: Leaks or restrictions in the vacuum circuits of vacuum assisted engine control system devices are not monitored by the PCM. However, a vacuum leak at the MAP sensor will be monitored and a diagnostic trouble code (DTC) will be generated by the PCM.

Powertrain Control Module (PCM) System Ground: The PCM cannot determine a poor system ground. However, a DTC may be generated as a result of this condition.

Powertrain Control Module (PCM) Connector Engagement: The PCM cannot determine spread or damaged connector pins. However, a DTC may be generated as a result of this condition.

HIGH AND LOW LIMITS

The powertrain control module (PCM) compares input signal voltages from each input device. It will establish high and low limits that are programmed into it for that device. If the input voltage is not within specifications and other Diagnostic Trouble Code (DTC) criteria are met, a DTC will be stored in memory. Other DTC criteria might include engine rpm limits or input voltages from other sensors or switches. The other inputs might have to be sensed by the PCM when it senses a high or low input voltage from the control system device in question.

ACCESSING DIAGNOSTIC TROUBLE CODES

A stored Diagnostic Trouble Code (DTC) can be displayed by cycling the ignition key On-Off-On-Off-On within three seconds and observing the Malfunction Indicator Lamp. This lamp was formerly referred to as the Check Engine Lamp. The lamp is located on the instrument panel.

They can also be displayed through the use of the Diagnostic Readout Box (DRB) scan tool. The DRB scan tool connects to the data link connector in the engine compartment (Figs. 45 or 46). For operation of the DRB, refer to the appropriate Powertrain Diagnostic Procedures service manual.

EXAMPLES:

- If the lamp flashes 4 times, pauses and flashes 1 more time, a flashing Diagnostic Trouble Code (DTC) number 41 is indicated.
- If the lamp flashes 4 times, pauses and flashes 6 more times, a flashing Diagnostic Trouble Code (DTC) number 46 is indicated.

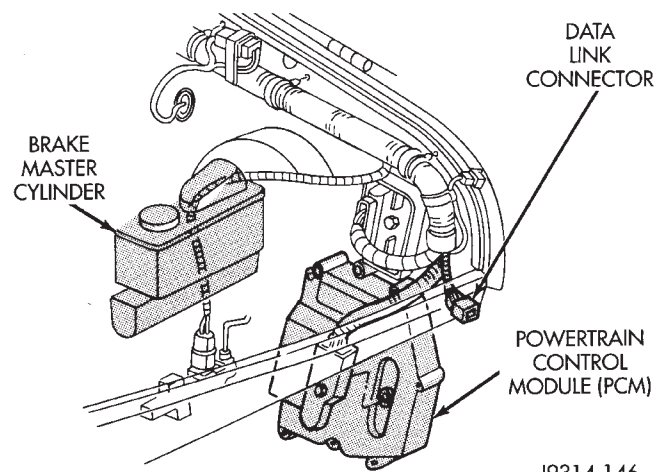

Fig. 45 Data Link Connector—YJ Models—Typical

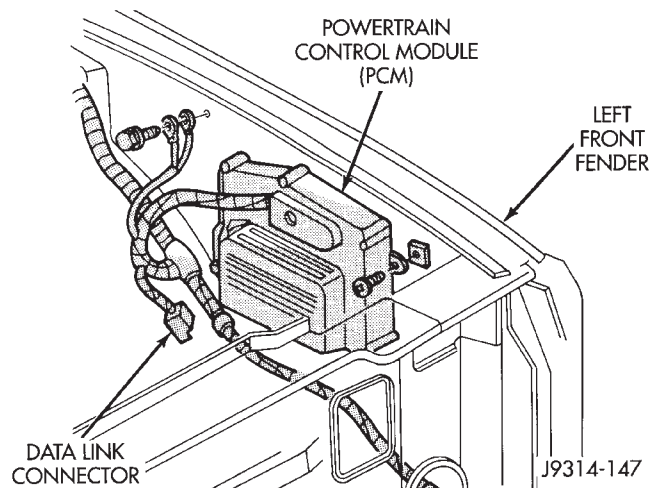

Fig. 46 Data Link Connector—XJ Models—Typical

After any stored DTC information has been observed, the display will end with a flashing DTC number 55. This will indicate the end of all stored information.

Refer to the Diagnostic Trouble Code (DTC) charts for DTC identification.

If the problem is repaired or ceases to exist, the Powertrain Control Module (PCM) cancels the DTC after 51 engine starts.

Diagnostic Trouble Codes indicate the results of a failure, but never identify the failed component directly.

The circuits of the data link connector are shown in (Fig. 47).

ERASING TROUBLE CODES

After the problem has been repaired, use the DRB scan tool to erase a Diagnostic Trouble Code (DTC). Refer to the appropriate Powertrain Diagnostic Procedures service manual for operation of the DRB scan tool.

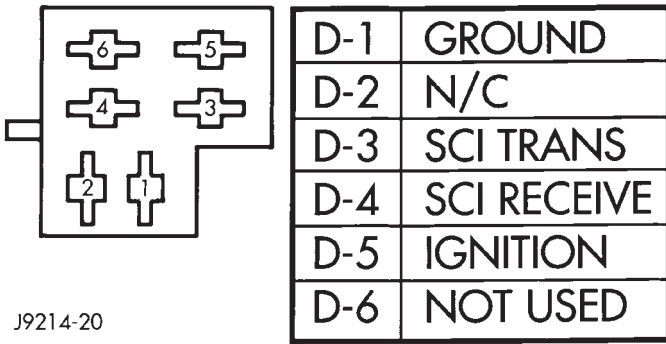

J9214-20

Fig. 47 Data Link Connector Schematic

DRB SCAN TOOL

For operation of the DRB scan tool, refer to the appropriate Powertrain Diagnostic Procedures service manual.

DIAGNOSTIC TROUBLE CODE (DTC)

On the following pages, a list of diagnostic trouble codes is provided for the 2.5L 4 cylinder and 4.0L 6 cylinder engines. A DTC indicates that the powertrain control module (PCM) has recognized an abnormal signal in a circuit or the system. A DTC may indicate the result of a failure, but never identify the failed component directly.

DIAGNOSTIC TROUBLE CODE DESCRIPTIONS

Diagnostic Trouble Code	DRB Scan Tool Display	Description of Diagnostic Trouble Code
11*	No Crank Reference Signal at PCM	No crank reference signal detected during engine cranking.
12*	Battery Disconnect	Direct battery input to PCM was disconnected within the last 50 Key-on cycles.
13**	No Change in MAP From Start to Run	No difference recognized between the engine MAP reading and the barometric (atmospheric) pressure reading at start-up.
14**	MAP Sensor Voltage Too Low	MAP sensor input below minimum acceptable voltage.
	or	
	MAP Sensor Voltage Too High	MAP sensor input above maximum acceptable voltage.
15**	No Vehicle Speed Sensor Signal	No vehicle distance (speed) sensor signal detected during road load conditions.
17*	Engine is Cold Too Long	Engine coolant temperature remains below normal operating temperatures during vehicle travel (thermostat).
21**	O2S Stays at Center	Neither rich or lean condition detected from the oxygen sensor input.
	or	
	O2S Shorted to Voltage	Oxygen sensor input voltage maintained above the normal operating range.
22**	ECT Sensor Voltage Too High	Engine coolant temperature sensor input above maximum acceptable voltage.
	or	
	ECT Sensor Voltage Too Low	Engine coolant temperature sensor input below minimum acceptable voltage.

* Check Engine Lamp will not illuminate at all times if this Diagnostic Trouble Code was recorded. Cycle Ignition key as described in manual and observe code flashed by Check Engine lamp.

** Check Engine Lamp will illuminate during engine operation if this Diagnostic Trouble Code was recorded.

DIAGNOSTIC TROUBLE CODE DESCRIPTIONS—CONTINUED

Diagnostic Trouble Code	DRB Scan Tool Display	Description of Diagnostic Trouble Code
23**	Intake Air Temp Sensor Voltage Low or Intake Air Temp Sensor Voltage High	Intake air temperature sensor input below the minimum acceptable voltage. Intake air temperature sensor input above the maximum acceptable voltage.
24**	Throttle Position Sensor Voltage High or Throttle Position Sensor Voltage Low	Throttle position sensor input above the maximum acceptable voltage. Throttle position sensor input below the minimum acceptable voltage.
25**	Idle Air Control Motor Circuits	A shorted condition detected in one or more of the idle air control motor circuits.
27*	Injector #1 Control Circuit or Injector #2 Control Circuit or Injector #3 Control Circuit or Injector #4 Control Circuit or Injector #5 Control Circuit or Injector #6 Control Circuit	Injector #1 output driver does not respond properly to the control signal. Injector #2 output driver does not respond properly to the control signal. Injector #3 output driver does not respond properly to the control signal. Injector #4 output driver does not respond properly to the control signal. Injector #5 output driver does not respond properly to the control signal. Injector #6 output driver does not respond properly to the control signal.
33*	A/C Clutch Relay Circuit	An open or shorted condition detected in the A/C clutch relay circuit.
34*	Speed Control Solenoid Circuits or Speed Control Switch Always Low or Speed Control Switch Always High	An open or shorted condition detected in the Speed Control vacuum or vent solenoid circuits. Speed Control switch input below the minimum acceptable voltage. Speed Control switch input above the maximum acceptable voltage.
35* (XJ Only)	Rad Fan Control Relay Circuits	An open or shorted condition detected in the radiator fan relay circuit.

* Check Engine Lamp will not illuminate at all times if this Diagnostic Trouble Code was recorded. Cycle Ignition key as described in manual and observe code flashed by Check Engine lamp.

** Check Engine Lamp will illuminate during engine operation if this Diagnostic Trouble Code was recorded.

DIAGNOSTIC TROUBLE CODE DESCRIPTIONS—CONTINUED

Diagnostic Trouble Code	DRB Scan Tool Display	Description of Diagnostic Trouble Code
41**	Generator Field Not Switching Properly	An open or shorted condition detected in the generator field control circuit.
42*	Auto Shutdown Relay Control Circuit	An open or shorted condition detected in the auto shutdown relay circuit.
44*	Battery Temp Sensor Volts out of Limit	An open or shorted condition exists in the engine coolant temperature sensor circuit or a problem exists in the PCM's battery temperature voltage circuit.
46**	Charging System Voltage Too High	Battery voltage sense input above target charging voltage during engine operation.
47**	Charging System Voltage Too Low	Battery voltage sense input below target charging during engine operation. Also, no significant change detected in battery voltage during active test of generator output.
51**	O2S Signal Stays Below Center (Lean)	Oxygen sensor signal input indicates lean air/fuel ratio condition during engine operation.
52**	O2S Signal Stays Above Center (Rich)	Oxygen sensor signal input indicates rich air/fuel ratio condition during engine operation.
53*	Internal PCM Failure or	PCM Internal fault condition detected.
	PCM Failure SPI Communications	PCM Internal fault condition detected.
54*	No Cam Sync Signal at PCM	No fuel sync (camshaft signal) detected during engine cranking.
55*	N/A	Completion of diagnostic trouble code display on the Malfunction Indicator Lamp (Check Engine Lamp).
62*	PCM Failure SPI miles not stored	Unsuccessful attempt to update SPI miles in the PCM EEPROM.
63*	PCM Failure EEPROM Write Denied	Unsuccessful attempt to write to an EEPROM location by the PCM.

* Check Engine Lamp will not illuminate at all times if this Diagnostic Trouble Code was recorded. Cycle Ignition key as described in manual and observe code flashed by Check Engine lamp.

** Check Engine Lamp will illuminate during engine operation if this Diagnostic Trouble Code was recorded.

MULTI-PORT FUEL INJECTION (MFI)—COMPONENT REMOVAL/INSTALLATION

INDEX

	page		page
Accelerator Pedal and Throttle Cable	54	Fuel Tubes/Lines/Hoses and Clamps	56
Air Cleaner Housing	54	Idle Air Control (IAC) Motor	56
Air Conditioning (A/C) Clutch Relay	54	Ignition Coil	57
Air Filter	54	Intake Air Temperature Sensor	54
Automatic Shut Down (ASD) Relay	54	Intake Manifold	57
Brake Switch	54	Manifold Absolute Pressure (MAP) Sensor	57
Camshaft Position Sensor	54	Oxygen (O2S) Sensor	57
Crankshaft Position Sensor	55	Park Neutral Switch	58
Engine Coolant Temperature Sensor	55	Power Steering Pressure Switch—2.5L Engine Only	58
Fuel Filter	55	Powertrain Control Module (PCM)	58
Fuel Injector	55	Quick-Connect Fittings	59
Fuel Pump Module	56	Throttle Body	59
Fuel Pump Relay	56	Throttle Position Sensor (TPS)	59
Fuel Rail Assembly	56	Torque Converter Clutch Relay	60
Fuel System Pressure Release Procedure	56	Vehicle Speed Sensor	60
Fuel Tank Pressure Relief/Rollover Valve	56		
Fuel Tanks	56		

ACCELERATOR PEDAL AND THROTTLE CABLE

Refer to the Accelerator Pedal and Throttle Cable section of this group for removal/installation procedures.

AIR CONDITIONING (A/C) CLUTCH RELAY

The A/C clutch relay is located in the Power Distribution Center (PDC) (Figs. 1 or 2). For location of this relay within the PDC, refer to label on PDC cover.

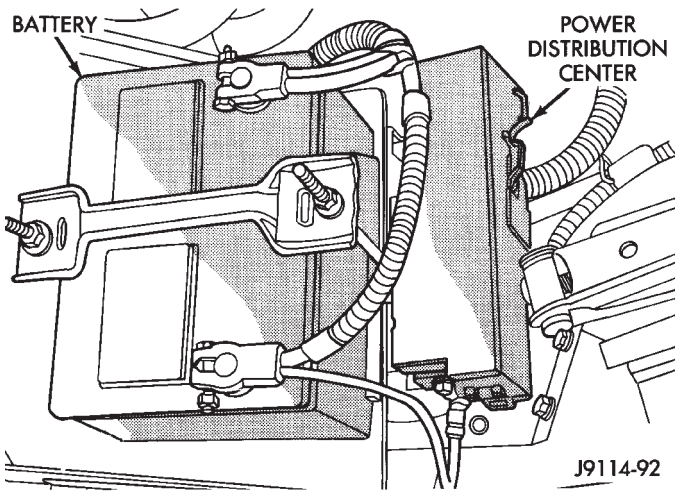

Fig. 1 PDC—YJ Models

AIR CLEANER HOUSING

Refer to Group 25, Emission Control System.

AIR FILTER

Refer to Group 25, Emission Control System.

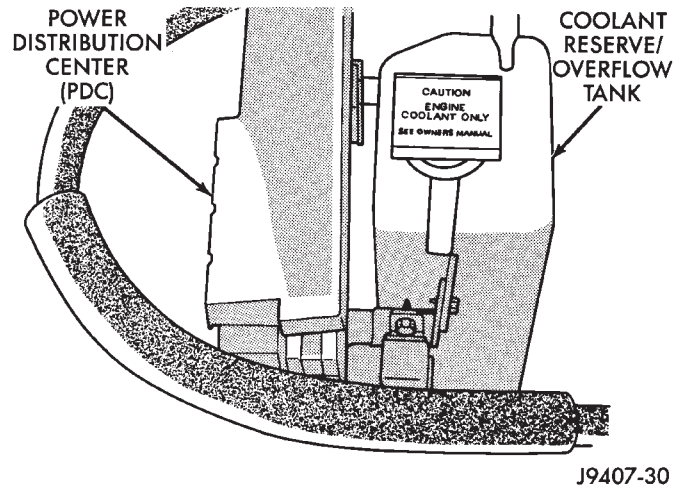

Fig. 2 PDC—XJ Models

AUTOMATIC SHUT DOWN (ASD) RELAY

The ASD relay is located in the Power Distribution Center (Figs. 1 or 2) (PDC). For location of this relay within the PDC, refer to label on PDC cover.

BRAKE SWITCH

Refer to Group 5, Brakes for removal/installation procedures.

CAMSHAFT POSITION SENSOR

For removal/installation procedures, refer to Group 8D, Ignition System. See Camshaft Position Sensor.

INTAKE AIR TEMPERATURE SENSOR

The intake manifold air temperature sensor is installed into the intake manifold plenum (Figs. 3 or 4).

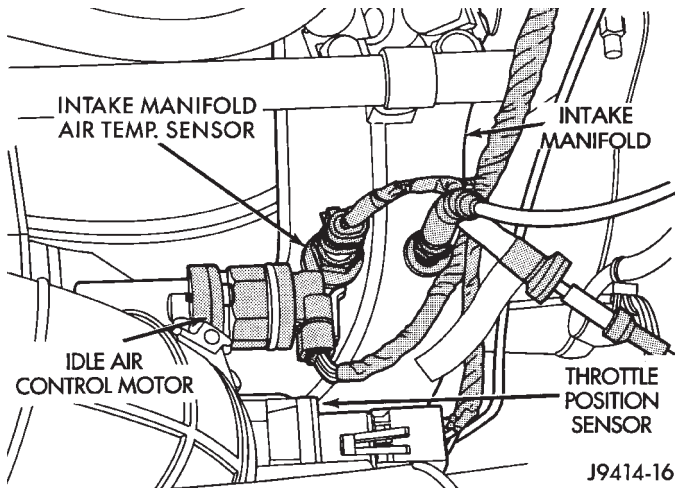

Fig. 3 Sensor Location—2.5L Engine

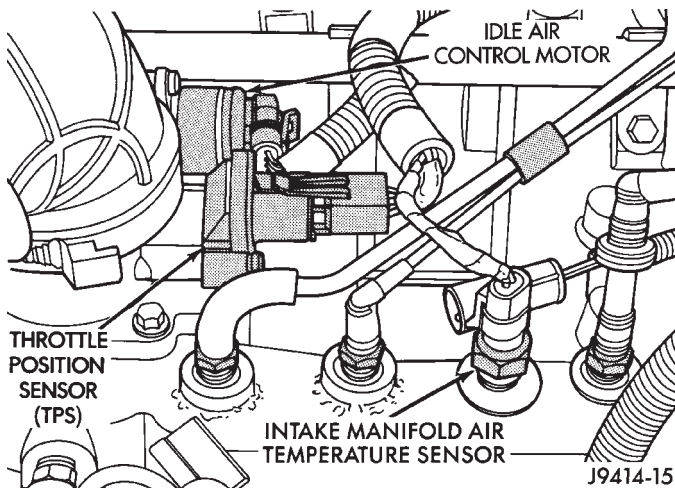

Fig. 4 Sensor Location—4.0L Engine

REMOVAL

- (1) Disconnect the electrical connector from the sensor.
- (2) Remove the sensor from the intake manifold.

INSTALLATION

- (1) Install the sensor into the intake manifold. Tighten the sensor to 28 N·m (20 ft. lbs.) torque.
- (2) Connect the electrical connector to the sensor.

CRANKSHAFT POSITION SENSOR

For description, operation and removal/installation procedures, refer to Group 8D, Ignition Systems in this manual.

ENGINE COOLANT TEMPERATURE SENSOR

The coolant temperature sensor is installed in the thermostat housing (Fig. 5).

REMOVAL

- (1) Drain cooling system until the coolant level is below the cylinder head. Observe the **WARNINGS** in Group 7, Cooling.

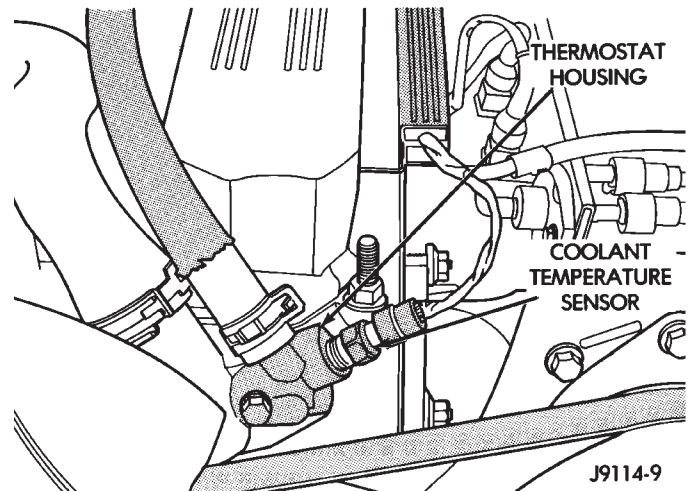

Fig. 5 Engine Coolant Temperature Sensor—Typical

- (2) Disconnect the coolant temperature sensor wire connector.
- (3) Remove the sensor from the thermostat housing (Fig. 5).

INSTALLATION

- (1) Install coolant temperature sensor into the cylinder block. Tighten to 28 N·m (21 ft. lbs.) torque.
- (2) Connect the wire connector.
- (3) Fill the cooling system. Refer to Group 7, Cooling System.

FUEL FILTER

Refer to the Fuel Delivery System section of this group for removal/installation procedures.

FUEL INJECTOR

REMOVAL

- (1) Remove the fuel rail. Refer to Fuel Rail Removal in this section.
- (2) Remove the clip(s) that retain the fuel injector(s) to the fuel rail (Fig. 6).

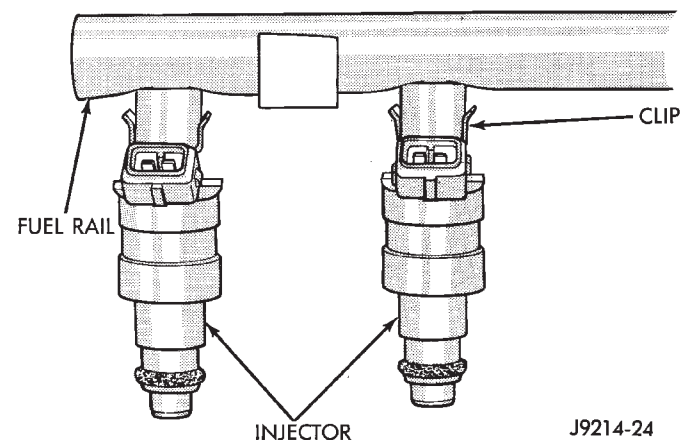

Fig. 6 Injector Retaining Clips

INSTALLATION

- (1) Install the fuel injector(s) into the fuel rail assembly and install retaining clip(s).
- (2) Install fuel rail. Refer to Fuel Rail Installation in this section.
- (3) Start engine and check for fuel leaks.

FUEL PUMP MODULE

Refer to the Fuel Delivery System section of this group for removal/installation procedures.

FUEL PUMP RELAY

The Fuel Pump relay is located in the Power Distribution Center (PDC) (Figs. 1 or 2). For location of this relay within the PDC, refer to label on PDC cover.

FUEL RAIL ASSEMBLY**REMOVAL**

WARNING: THE FUEL SYSTEM IS UNDER CONSTANT FUEL PRESSURE (EVEN WITH THE ENGINE OFF) OF APPROXIMATELY 131-269 KPA (19-39 PSI). THIS PRESSURE MUST BE RELEASED BEFORE SERVICING THE FUEL RAIL.

- (1) Remove fuel tank filler tube cap.
- (2) Disconnect the negative battery cable from battery.
- (3) Perform the Fuel System Pressure Release Procedure as described in the Fuel Delivery System section of this Group.
- (4) Remove and numerically attach a tag (if fuel injector is not already tagged), the injector harness connectors. Do this at each injector (Fig. 7).

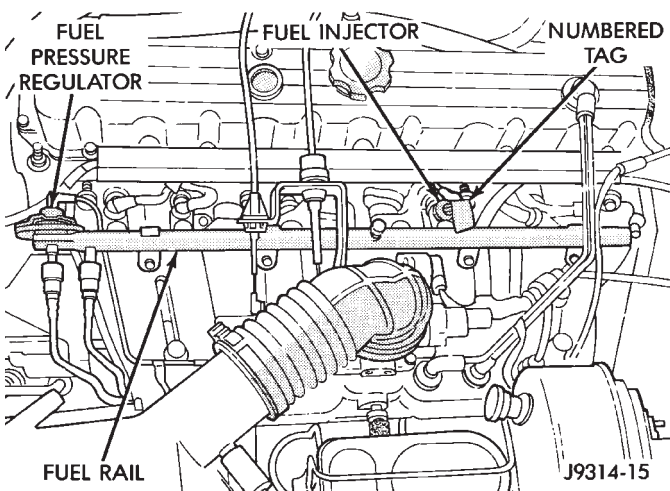

Fig. 7 Fuel Injector Harness—Typical

- (5) Disconnect vacuum line from fuel pressure regulator (Fig. 7).
- (6) Disconnect fuel supply line from fuel rail and the fuel return line from fuel pressure regulator (Fig.

7). Refer to Fuel Tubes/Lines/Hoses and Clamps, or Quick-Connect Fittings. These can both be found in the Fuel Delivery section of this group.

- (7) Remove fuel rail mounting bolts.

On models with automatic transmissions, it may be necessary to remove automatic transmission throttle line pressure cable (and bracket). This will aid in fuel rail assembly removal.

- (8) Remove fuel rail by gently rocking until all the fuel injectors are out of the intake manifold.

INSTALLATION

(1) Position tips of all fuel injectors into the corresponding injector bore in the intake manifold. Seat injectors into manifold.

- (2) Tighten fuel rail mounting bolts to 27 N·m (20 ft. lbs.) torque.

(3) Connect injector harness connectors to appropriate (tagged) injector.

- (4) Connect both fuel lines to fuel rail.

(5) Connect vacuum supply line to fuel pressure regulator.

(6) Install protective cap to pressure test port fitting.

- (7) Install fuel tank cap.

- (8) Connect negative battery cable to battery.

- (9) Start engine and check for fuel leaks.

FUEL SYSTEM PRESSURE RELEASE PROCEDURE

WARNING: THE FUEL SYSTEM IS UNDER A CONSTANT PRESSURE (EVEN WITH THE ENGINE OFF) OF APPROXIMATELY 100 KPA (14.5 PSI). BEFORE SERVICING THE FUEL PUMP, FUEL LINES, FUEL FILTER OR FUEL INJECTOR, THE FUEL SYSTEM PRESSURE MUST BE RELEASED.

Refer to the Fuel Delivery System section of this group. See Fuel Pressure Release procedure.

FUEL TANKS

Refer to the Fuel Tank section of this group for removal/installation procedures.

FUEL TANK PRESSURE RELIEF/ROLLOVER VALVE

Refer to the Fuel Tank section of this group for removal/installation procedures.

FUEL TUBES/LINES/HOSES AND CLAMPS

Refer to the Fuel Delivery System section of this group for removal/installation procedures. Also refer to Quick-Connect Fittings in the Fuel Delivery section of this group.

IDLE AIR CONTROL (IAC) MOTOR

The IAC motor is mounted to the throttle body adjacent to the throttle position sensor (Fig. 8).

REMOVAL

(1) Disconnect the electrical connector from the IAC motor.

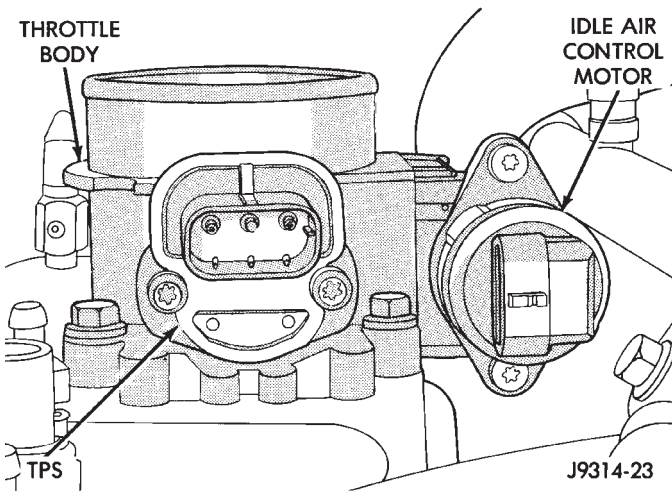

Fig. 8 Idle Air Control Motor—Removal/Installation—Typical

- (2) Remove IAC motor torx head mounting bolts.
- (3) Remove IAC motor.

INSTALLATION

- (1) Install IAC motor into throttle body and tighten retaining bolts.
- (2) Connect electrical connector to IAC motor.

IGNITION COIL

Refer to Group 8D, Ignition Systems for removal/installation procedures.

INTAKE MANIFOLD

Refer to Group 11, Exhaust System and Intake Manifold for removal/installation procedures.

MANIFOLD ABSOLUTE PRESSURE (MAP) SENSOR

The MAP sensor is located on the dash panel near the rear of the engine cylinder head (valve) cover (Fig. 9).

REMOVAL

- (1) Disconnect the MAP sensor electrical connector (Fig. 9).
- (2) Disconnect the MAP sensor vacuum supply hose (Fig. 9).
- (3) Remove the MAP sensor mounting bolts and remove MAP sensor.

INSTALLATION

- (1) Install MAP sensor to dash panel and secure with mounting bolts.
- (2) Install the MAP sensor vacuum supply hose.
- (3) Connect the MAP sensor electrical connector.

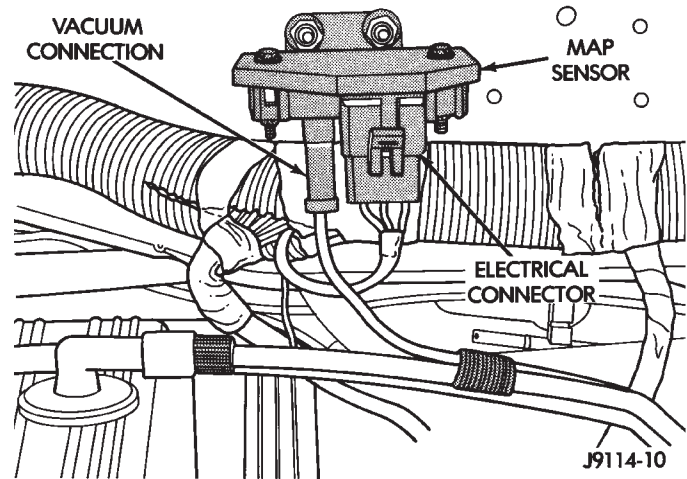

Fig. 9 MAP Sensor—Typical

OXYGEN (O2S) SENSOR

The O2S sensor is installed in the exhaust down pipe just below the exhaust manifold flange (Fig. 10).

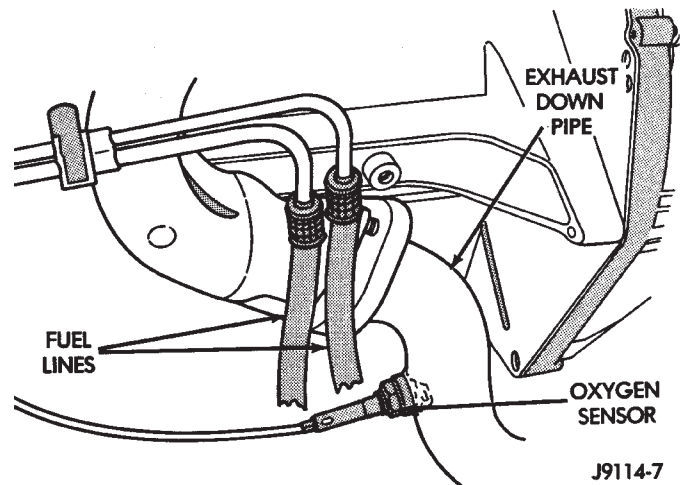

Fig. 10 Oxygen Sensor—Typical

REMOVAL

WARNING: THE EXHAUST MANIFOLD BECOMES VERY HOT DURING ENGINE OPERATION. ALLOW ENGINE TO COOL BEFORE REMOVING OXYGEN SENSOR.

- (1) Raise and support the vehicle.
- (2) Separate the electrical connectors.
- (3) Remove the O2S sensor from the exhaust manifold. Snap-On oxygen sensor wrench (number YA 8875) may be used for removal and installation.

INSTALLATION

Threads of new factory oxygen sensors are coated with anti-seize compound to aid in removal.

- (1) Install the O2S sensor into the exhaust manifold and tighten to 30 N·m (22 ft. lbs.) torque.
- (2) Connect the O2S sensor wire connector to the main harness.

(3) Lower the vehicle.

PARK NEUTRAL SWITCH

Refer to Group 21, Transmissions for park neutral switch service.

POWER STEERING PRESSURE SWITCH—2.5L ENGINE ONLY

The power steering pressure switch is installed in the power steering high pressure hose (Figs. 11 or 12).

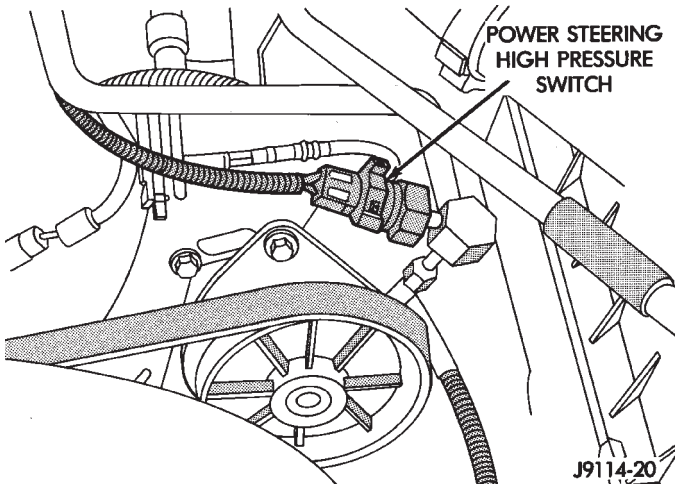

Fig. 11 Power Steering Pressure Switch—YJ Models

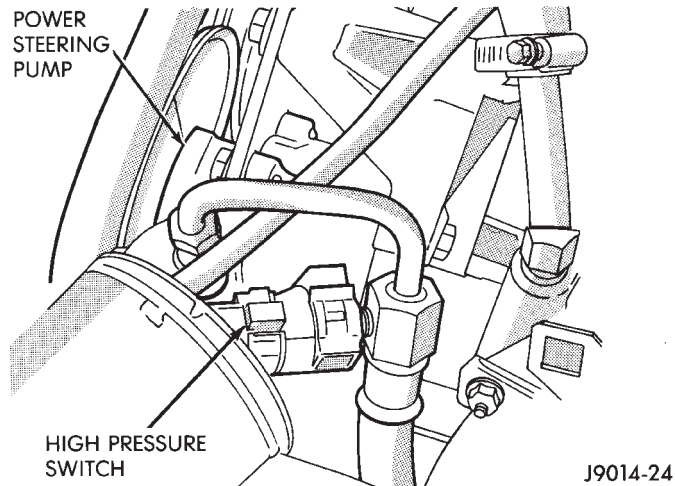

Fig. 12 Power Steering Pressure Switch—XJ Models

REMOVAL

- (1) Disconnect the electrical connector from the power steering pressure switch.
- (2) Place a small container or shop towel beneath the switch to collect any excess fluid.
- (3) Remove the switch.

INSTALLATION

- (1) Install the power steering switch.
- (2) Connect the electrical connector to the switch.

(3) Check power steering fluid and add as necessary.

(4) Start the engine and again check power steering fluid. Add fluid if necessary.

POWERTRAIN CONTROL MODULE (PCM)

On XJ models, the PCM is located in the engine compartment next to the air cleaner (Fig. 13). On YJ models, the PCM is located in the engine compartment behind the windshield washer fluid reservoir (Fig. 14).

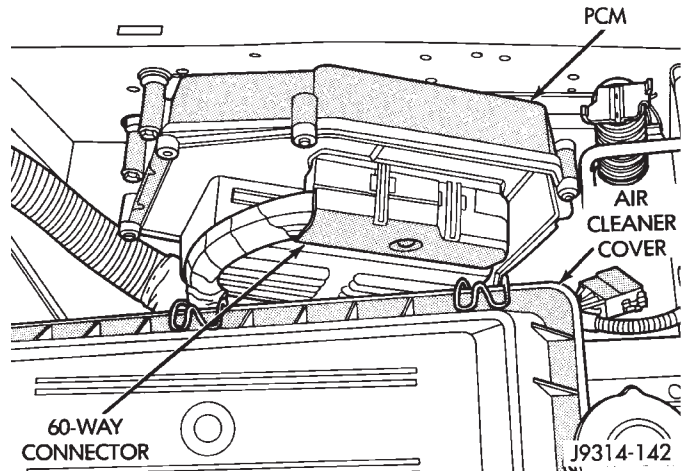

Fig. 13 PCM Location—XJ Models

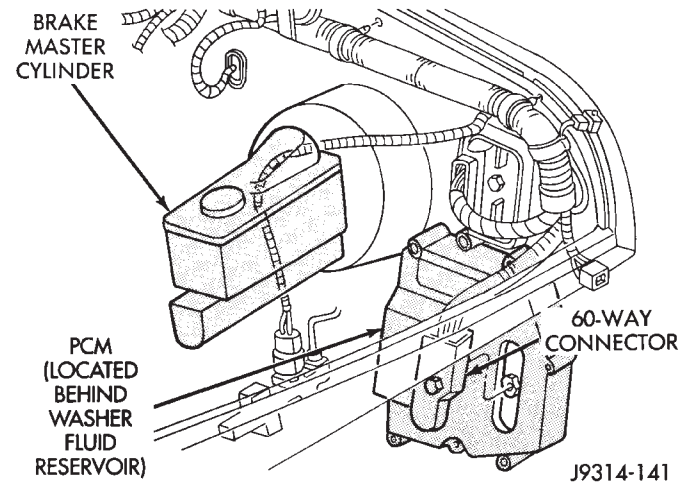

Fig. 14 PCM Location—YJ Models

REMOVAL

- (1) Disconnect the negative battery cable at the battery.
- (2) YJ Models Only: Remove the windshield washer fluid tank.
- (3) Loosen the 60-Way connector mounting bolt (Figs. 13 or 14).
- (4) Remove the electrical connector by pulling straight back.
- (5) Remove the three PCM mounting bolts.
- (6) Remove PCM.

INSTALLATION

(1) After the PCM electrical connector has been separated from the PCM, inspect the pins for corrosion, being spread apart, bent or misaligned. Also inspect the pin heights in the connector. If the pin heights are different, this would indicate a pin has separated from the connector. Repair as necessary.

(2) Install PCM. Tighten three mounting bolts to 1 N·m (9 in. lbs.) torque.

(3) Engage 60-way connector into PCM. Tighten connector mounting bolt to 4 N·m (35 in. lbs.) torque.

(4) YJ Models: Install windshield washer fluid tank.

(5) Connect negative cable to battery.

QUICK-CONNECT FITTINGS

Refer to the Fuel Delivery System section of this group for removal/installation procedures.

THROTTLE BODY

REMOVAL

- (1) Disconnect the negative battery cable.
- (2) Disconnect air cleaner hose from throttle body.
- (3) Disconnect idle air control motor and throttle position sensor wire connectors.
- (4) Disconnect accelerator cable, throttle cable (automatic transmission) and speed control cable (if equipped) from throttle arm (Fig. 15).

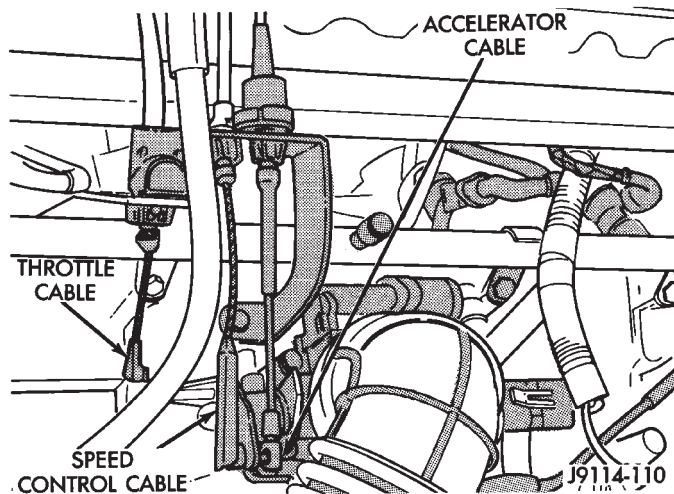

Fig. 15 Cables at Throttle Body

(5) Remove throttle body mounting bolts, throttle body and gasket. Discard old gasket (Fig. 16).

INSTALLATION

(1) Install throttle body and new gasket. Tighten throttle body mounting bolts to 12 N·m (9 ft. lbs.) torque.

(2) Connect idle air control motor and throttle position sensor wire connectors.

(3) Connect throttle linkage to throttle arm.

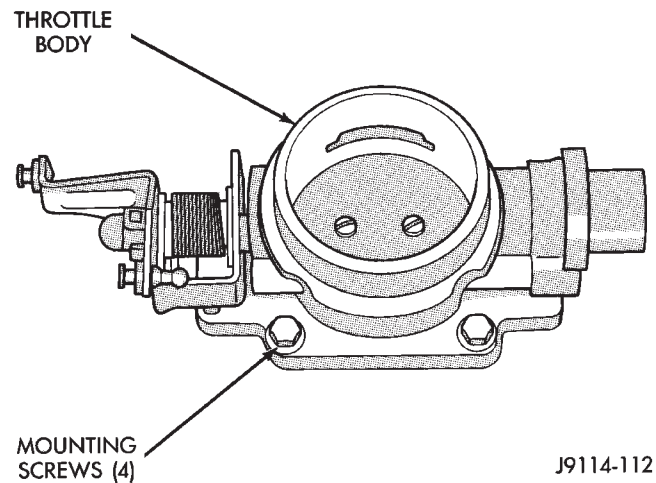

Fig. 16 Throttle Body—Removal/Installation—Typical

CAUTION: When the automatic transmission throttle cable is connected, it **MUST** be adjusted.

(4) If equipped with an automatic transmission, connect and adjust the transmission line pressure cable. Refer to Group 21, Transmissions for adjustment procedure.

(5) Install air cleaner hose to throttle body.

(6) Connect negative battery cable to battery.

THROTTLE POSITION SENSOR (TPS)

The TPS is mounted to the throttle body (Figs. 17 or 18).

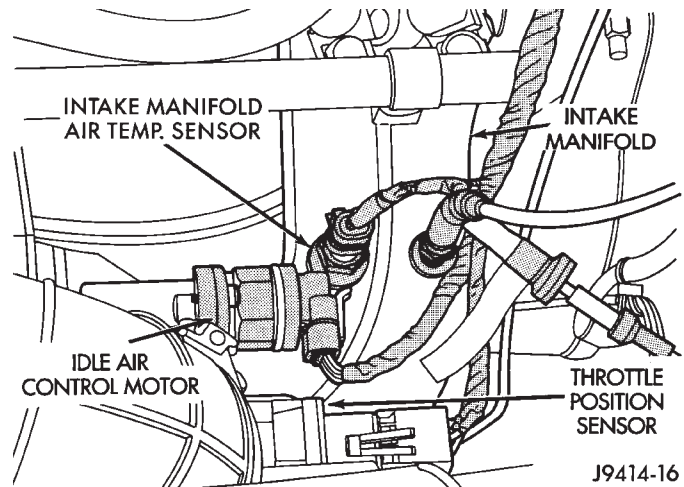

Fig. 17 TPS Location—2.5L Engine

REMOVAL

- (1) Disconnect TPS electrical connector.
- (2) Remove TPS mounting bolts.
- (3) Remove TPS.

INSTALLATION

The throttle shaft end of the throttle body slides into a socket in the TPS (Fig. 19). The TPS must be installed so that it can be rotated a few degrees. (If

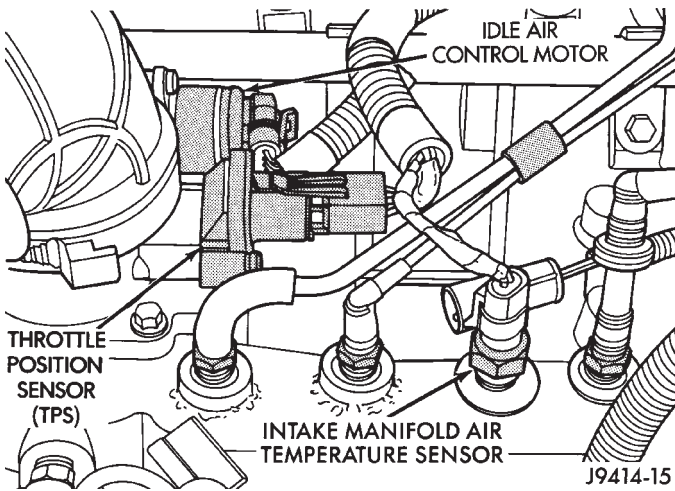

Fig. 18 TPS Location—4.0L Engine

the sensor will not rotate, install the sensor with the throttle shaft on the other side of the socket tangs). The TPS will be under slight tension when rotated.

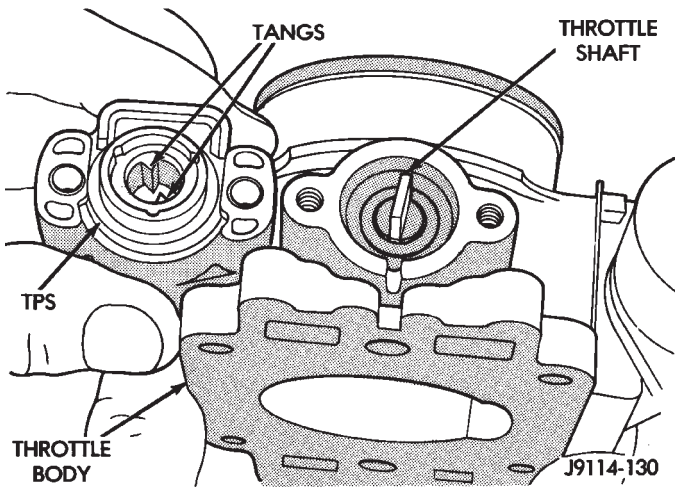

Fig. 19 Throttle Position Sensor—Installation

- (1) Install the TPS and retaining bolts.
- (2) Connect TPS electrical connector to TPS.
- (3) Manually operate the throttle (by hand) to check for any TPS binding before starting the engine.

TORQUE CONVERTER CLUTCH RELAY

On YJ models, the TCC relay is located in the engine compartment. It is attached to the cowl panel with one bolt (Fig. 20). On XJ models, the TCC relay is located in the power distribution center (PDC) (Fig. 21). For location of this relay within the PDC, refer to label on PDC cover.

VEHICLE SPEED SENSOR

The vehicle speed sensor (Fig. 22) is located on the extension housing of the transmission on 2WD models. It is located on the transfer case on 4WD models.

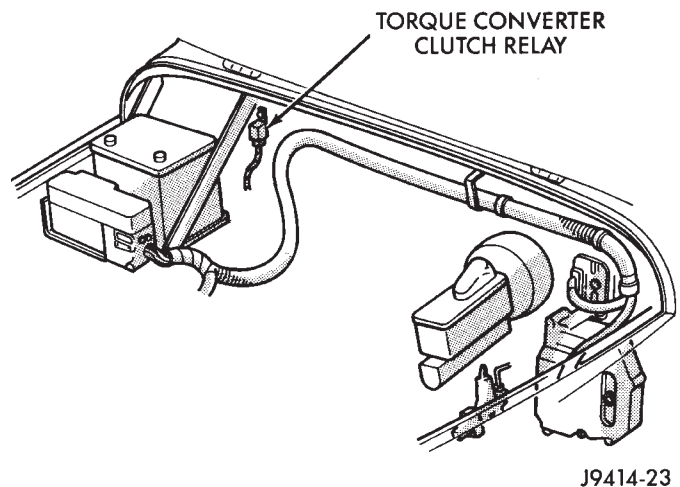

Fig. 20 TCC Relay Location—YJ Models

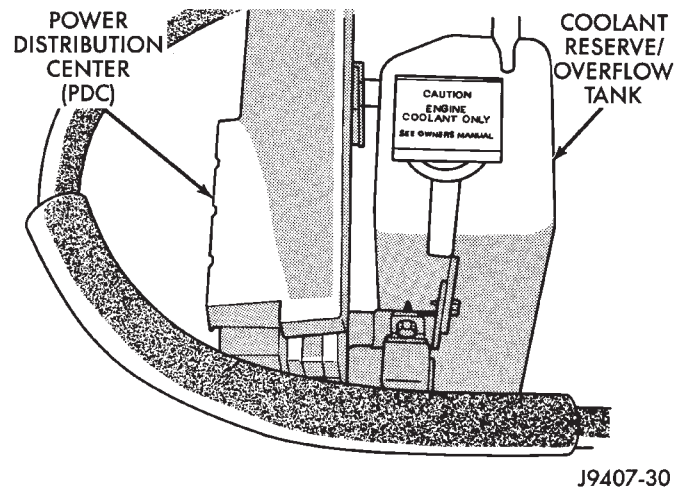

Fig. 21 Power Distribution Center—XJ Models

REMOVAL

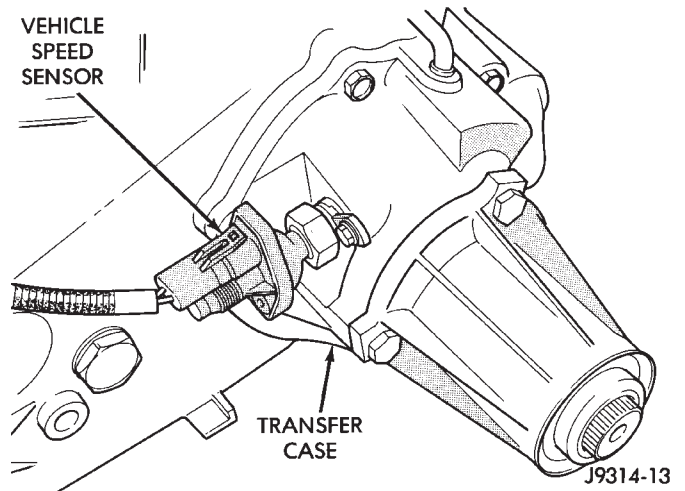
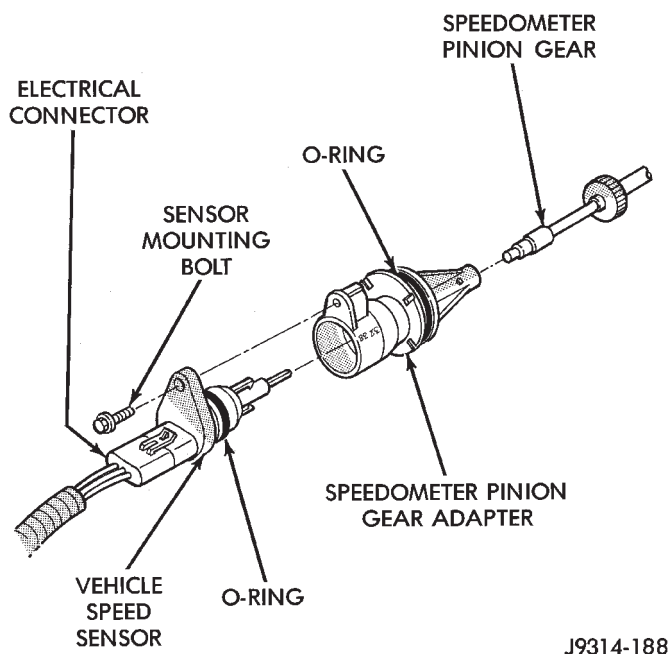

Fig. 22 Vehicle Speed Sensor Location—Typical

- (1) Raise and support vehicle.
- (2) Disconnect the electrical connector from the sensor.
- (3) Remove the sensor mounting bolt (Fig. 23).



J9314-188

Fig. 23 Sensor Removal/Installation—Typical

(4) Remove the sensor (pull straight out) from the speedometer pinion gear adapter (Fig. 23). Do not remove the gear adapter from the transmission.

INSTALLATION

(1) Clean the inside of speedometer pinion gear adapter before installing speed sensor.

(2) Install sensor into speedometer gear adapter and install mounting bolt. **Before tightening bolt, verify speed sensor is fully seated (mounted flush) to speedometer pinion gear adapter.**

(3) Tighten sensor mounting bolt to 2.2 N·m (20 in. lbs.) torque.

(4) Connect electrical connector to sensor.

SPECIFICATIONS

GENERAL INFORMATION

The following specifications are published from the latest information available at the time of publication. **If anything differs between the specifications found on the Vehicle Emission Control Information (VECI) label and the following specifications, use specifications on VECI label.** The VECI label is located in the engine compartment.

FUEL TANK CAPACITIES

FUEL TANK	GALLONS*	LITERS*
XJ	20.02	76
YJ	20.0	76
YJ	15.0	57

*Nominal refill capacities are shown. A variation may be observed from vehicle to vehicle due to manufacturing tolerances, ambient temperature and refill procedure.

J9314-143

FUEL SYSTEM

COMPONENT	RATING
MFI Fuel System Pressure (with vacuum applied to regulator)	214 kPa (31 psi)
MFI Fuel System Pressure (without vacuum applied to pressure regulator)	269-276 kPa (39-41 psi)
MFI Fuel System Pressure Drop (fuel pump not engaged).....	Up to 138 kPa (20 psi)
Pressure-Vacuum Filler Cap Relief..	10 kPa (1.5 psi) pressure 6 kPa (1.8 in. Hg) vacuum

J9414-18

TORQUE

DESCRIPTION	TORQUE
Accelerator Pedal Bracket Mounting Nuts	4 N·m (36 in. lbs.)
Intake Manifold Air Temperature Sensor	28 N·m (20 ft. lbs.)
Engine Coolant Temperature Sensor	28 N·m (21 ft. lbs.)
PCM Mounting Screws	1 N·m (9 in. lbs.)
PCM 60-Way Connector Screw	4 N·m (35 in. lbs.)
Fuel Filter Retaining Strap	12 N·m (106 in. lbs.)
Fuel Pump/Gauge Send. Unit-to-Fuel Tank Screws (YJ)	2 N·m (18 in. lbs.)
Fuel Pump Line Nut	25 N·m (18 ft. lbs.)
Fuel Rail Mounting Bolts	27 N·m (20 ft. lbs.)
Fuel Tank Mounting Strap Nut (XJ)	11 N·m (100 in. lbs.)
Fuel Tank Skid Plate (YJ)	7 N·m (65 in. lbs.)
Fuel Tank Mounting Strap Nut (YJ)	18 N·m (13 ft. lbs.)
Oxygen Sensor	30 N·m (23 ft. lbs.)
Throttle Body Mtg. Bolts	12 N·m (9 ft. lbs.)

J9414-17