

COOLING SYSTEM

CONTENTS

	page		page
DIAGNOSIS	4	GENERAL INFORMATION	1
ENGINE ACCESSORY DRIVE BELTS	31	SERVICE PROCEDURES	9
ENGINE BLOCK HEATER	37	SPECIFICATIONS	38

GENERAL INFORMATION

Throughout this group, references are made to particular vehicle models by alphabetical designation (XJ or YJ) or by the particular vehicle nameplate. A chart showing a breakdown of alphabetical designations is included in the Introduction section at the beginning of this manual.

COOLING SYSTEM

The cooling system regulates engine operating temperature. It allows the engine to reach normal operating temperature as quickly as possible, maintains normal operating temperature and prevents overheating.

The cooling system also provides a means of heating the passenger compartment and cooling the automatic transmission fluid (if equipped). The cooling system is pressurized and uses a centrifugal water pump to circulate coolant throughout the system.

An optional factory installed heavy duty cooling package is available on most models. The package consists of a radiator that has an increased number

of cooling fins. XJ models equipped with a 4.0L 6 cylinder engine and heavy duty cooling and/or air conditioning also have an auxiliary electric cooling fan.

COOLING SYSTEM COMPONENTS

The cooling system consists of:

- A radiator
- Cooling fan (mechanical and/or electrical)
- Thermal viscous fan drive
- Fan shroud
- Radiator pressure cap
- Thermostat
- Coolant reserve/overflow system
- Transmission oil cooler (if equipped with an automatic transmission)
- Coolant
- Water pump
- Hoses and hose clamps

SYSTEM COOLANT ROUTING

For cooling system flow routings, refer to Figs. 1, 2, 3 or 4.

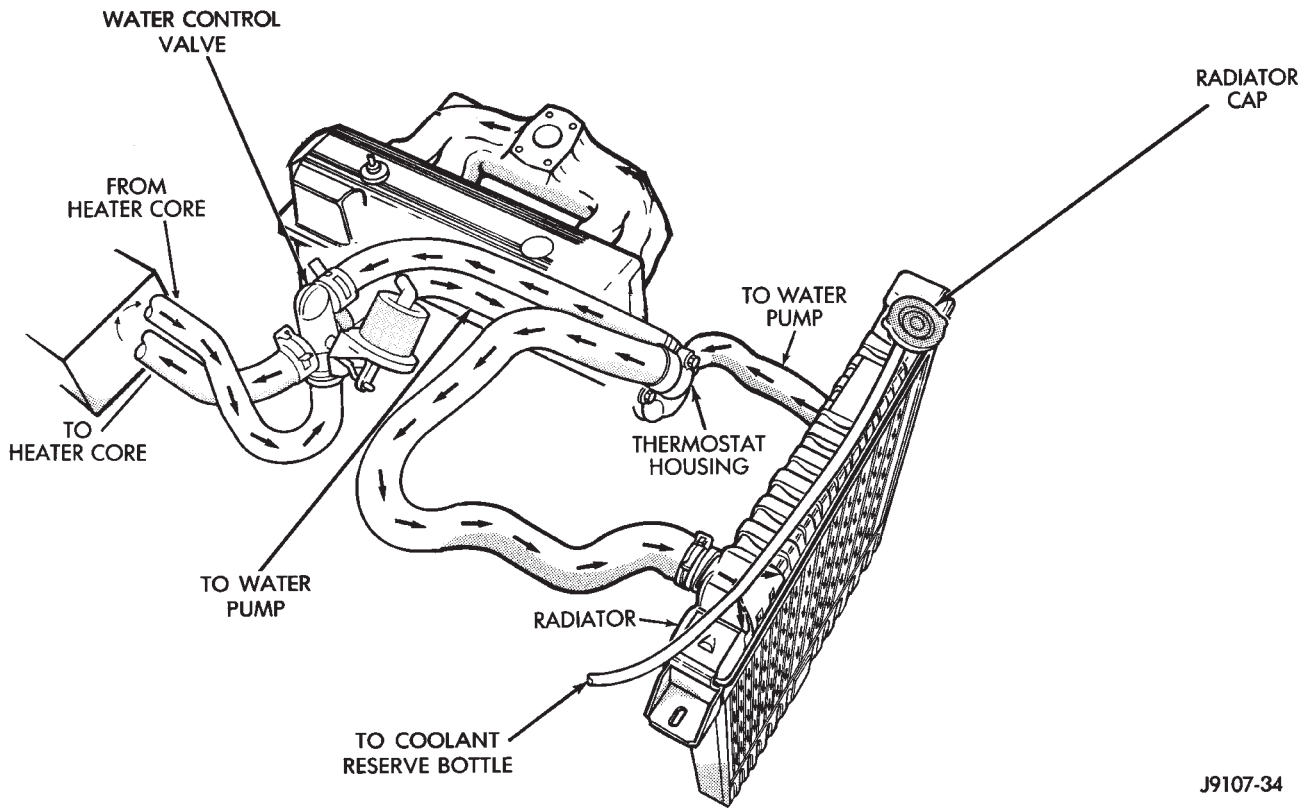

J9107-34

Fig. 1 Coolant Flow—XJ Models with 2.5L Engine—Typical

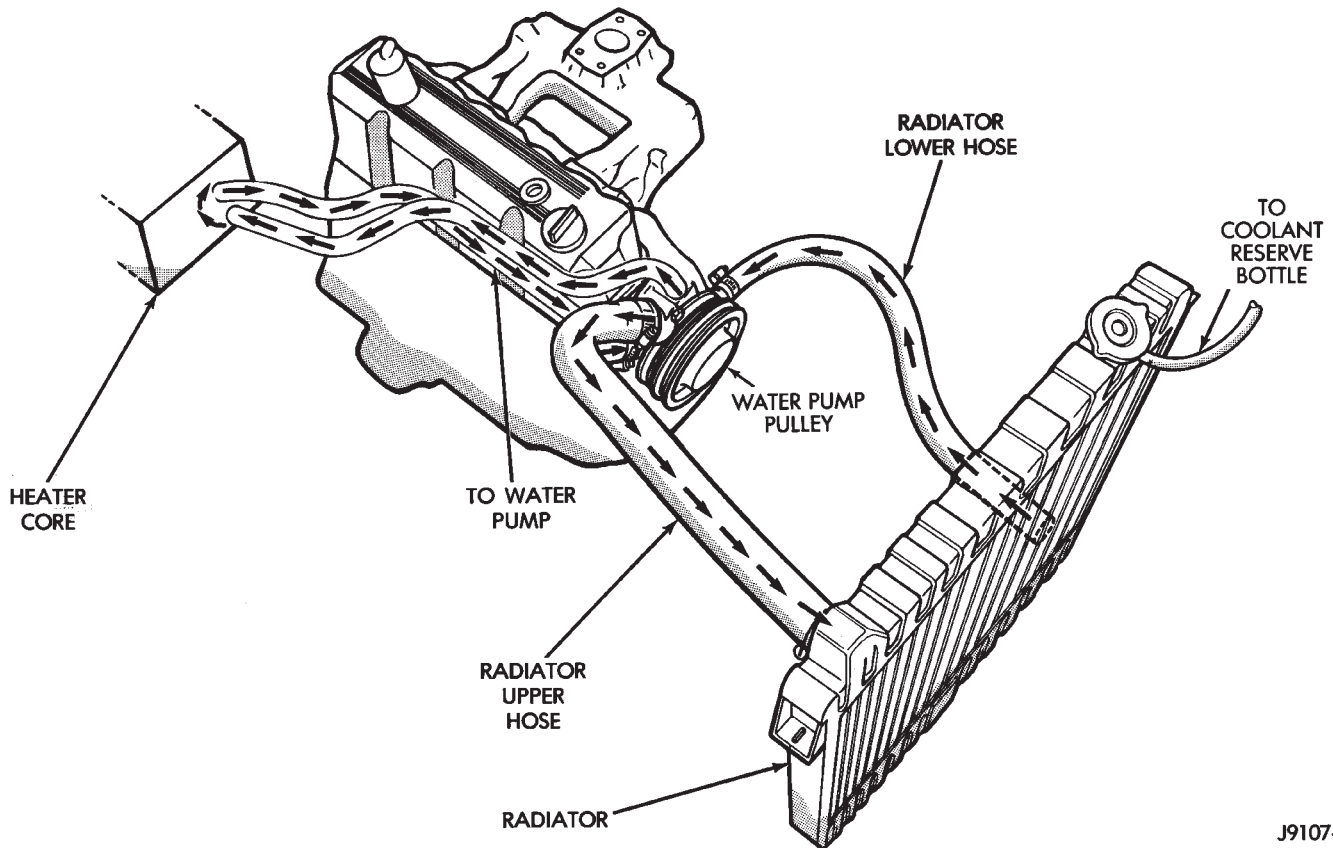

J9107-33

Fig. 2 Coolant Flow—YJ Models with 2.5L Engine—Typical

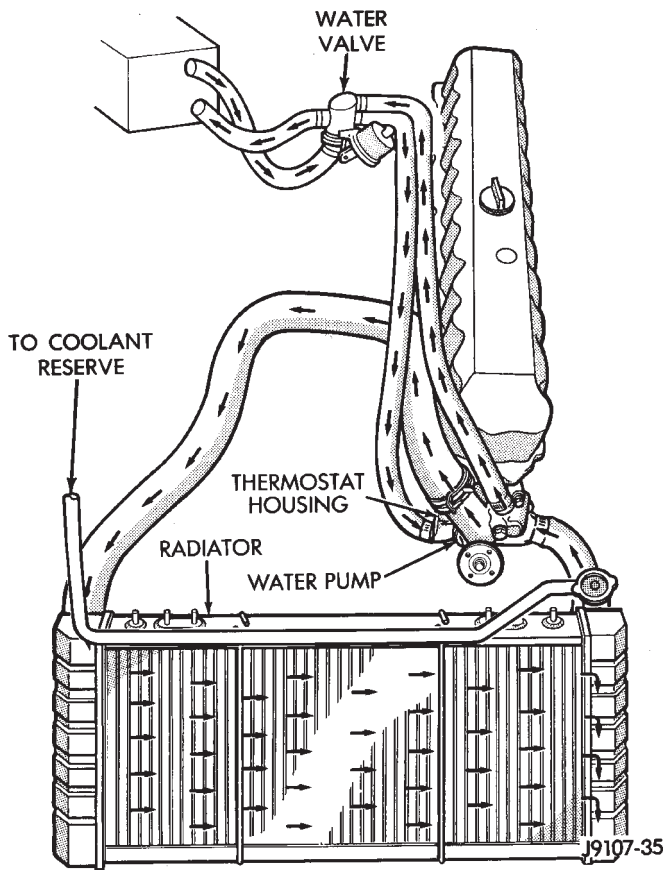

Fig. 3 Coolant Flow—XJ Models with 4.0L Engine—Typical

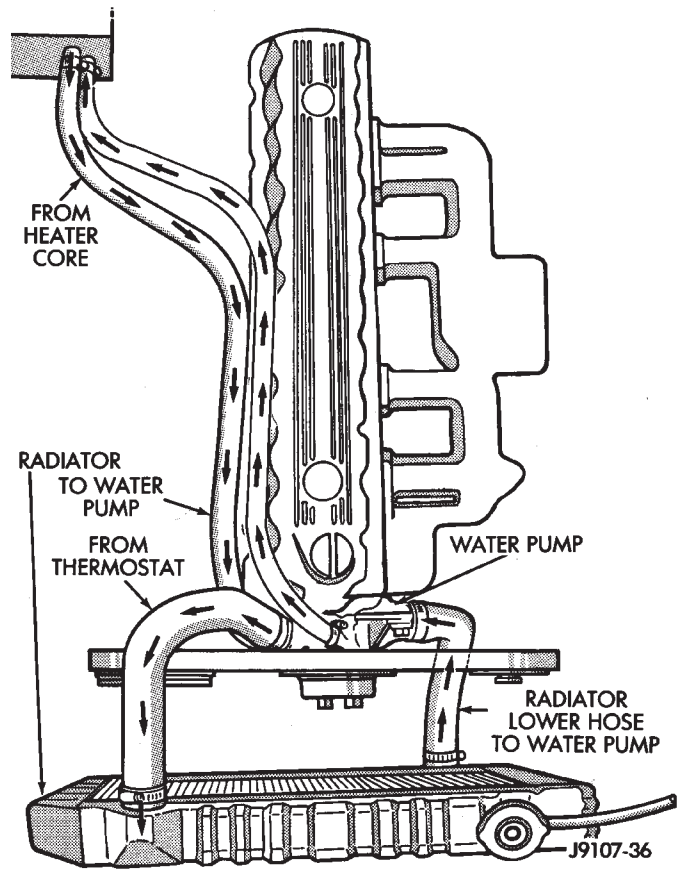

Fig. 4 Coolant Flow—YJ Models with 4.0L Engine—Typical

DIAGNOSIS

INDEX

	page		page
DRB Scan Tool	5	Preliminary Checks	5
On-Board Diagnostics (OBD)	4		

ON-BOARD DIAGNOSTICS (OBD)

FOR COOLING SYSTEM COMPONENTS

The powertrain control module (PCM) has been programmed to monitor the certain following cooling system components:

- If the engine has remained cool for too long a period, such as with a stuck open thermostat, a Diagnostic Trouble Code (DTC) number 17 can be observed at the Check Engine Lamp.
- If an open or shorted condition has developed in the relay circuit controlling the electric radiator fan, a Diagnostic Trouble Code (DTC) number 35 can be observed at the Check Engine Lamp.

If the problem is sensed in a monitored circuit often enough to indicate an actual problem, a DTC is stored. The DTC will be stored in the PCM memory for eventual display to the service technician. If the problem is repaired or ceases to exist, the PCM cancels the DTC after 51 engine starts.

Certain criteria must be met for a DTC to be entered into PCM memory. The criteria may be a specific range of engine rpm, engine temperature and/or input voltage to the PCM.

A DTC indicates that the PCM has recognized an abnormal signal in a circuit or the system. A DTC may indicate the result of a failure, but never identify the failed component directly.

It is possible that a DTC for a monitored circuit may not be entered into memory even though a malfunction has occurred. Refer to On-Board Diagnostics (OBD) in Group 14, Fuel Systems for additional information.

ACCESSING DIAGNOSTIC TROUBLE CODES

A stored Diagnostic Trouble Code (DTC) can be displayed by cycling the ignition key On-Off-On-Off-On within three seconds and observing the Malfunction Indicator Lamp. This lamp was formerly referred to as the Check Engine Lamp. The lamp is located on the instrument panel.

They can also be displayed through the use of the Diagnostic Readout Box (DRB) scan tool. The DRB connects to the data link connector in the engine compartment (Figs. 5 or 6). For operation of the DRB, refer to the appropriate Powertrain Diagnostic Procedures service manual.

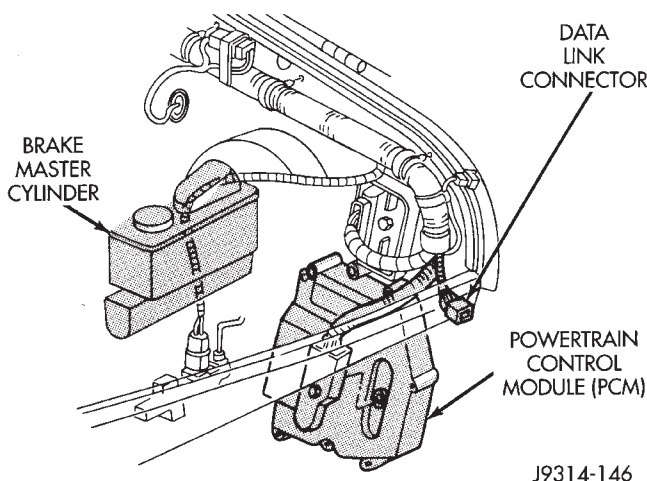

Fig. 5 Data Link Connector—YJ Models—Typical

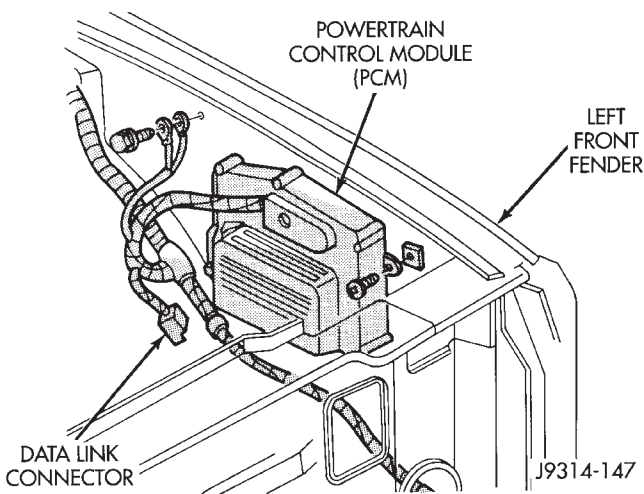

Fig. 6 Data Link Connector—XJ Models—Typical

EXAMPLES:

- If the lamp flashes 1 time, pauses and flashes 7 more times, a flashing Diagnostic Trouble Code (DTC) number 17 is indicated.
- If the lamp flashes 3 times, pauses and flashes 5 more times, a flashing Diagnostic Trouble Code (DTC) number 35 is indicated.

After any stored DTC information has been observed, the display will end with a flashing DTC number 55. This will indicate the end of all stored information.

ERASING TROUBLE CODES

After the problem has been repaired, the DRB scan tool must be used to erase a DTC. Refer to the appropriate Powertrain Diagnostic Procedures service manual for operation of the DRB scan tool.

DRB SCAN TOOL

For operation of the DRB scan tool, refer to the appropriate Powertrain Diagnostic Procedures service manual.

PRELIMINARY CHECKS

ENGINE COOLING SYSTEM OVERHEATING

Establish what driving conditions caused the complaint. Abnormal loads on the cooling system such as the following may be the cause.

1. PROLONGED IDLE, VERY HIGH AMBIENT TEMPERATURE, SLIGHT TAIL WIND AT IDLE, SLOW TRAFFIC, TRAFFIC JAMS, HIGH SPEED, OR STEEP GRADES:

Driving techniques that avoid overheating are:

- Idle with A/C off when temperature gauge is at end of normal range.
- Increasing engine speed for more air flow is recommended.

2. TRAILER TOWING:

Consult Trailer Towing section of owners manual. Do not exceed limits.

3. AIR CONDITIONING; ADD-ON OR AFTER MARKET:

A maximum cooling package should have been ordered with vehicle if add-on or after market A/C is installed. If not, maximum cooling system components should be installed for model involved per manufacturer's specifications.

4. RECENT SERVICE OR ACCIDENT REPAIR:

Determine if any recent service has been performed on vehicle that may effect cooling system. This may be:

- Engine adjustments (incorrect timing)
- Slipping engine accessory drive belt(s)
- Brakes (possibly dragging)
- Changed parts (incorrect water pump rotating in wrong direction)
- Reconditioned radiator or cooling system refilling (possibly under-filled or air trapped in system).

If investigation reveals none of the above as a cause for engine overheating complaint, refer to following Symptom and Action chart.

SYMPTOM AND ACTION—SEE PRELIMINARY CHECKS FIRST

Symptom	Action
Blinking Engine Temperature Warning Light Or High Gauge Indication-Without Coolant Loss	Normal with temporary operation with heavy load, towing a trailer, high outdoor temperatures, and/or on a steep grade.
Coolant Loss	Improper refilling procedures can result in trapped air in the system. Subsequent operation of the pressure cap and coolant reserve system will deaerate the cooling system. A low coolant level will then result in the coolant reserve tank. Add coolant. If condition persists, see System Diagnosis.
Hot Vehicle (Not Engine): Heat Damage, Hot Carpet, Seat, Hot Catalytic Converter, Smoke, Burnt Odor	Check heat shielding, exhaust system, engine emission controls, ignition timing, engine misfiring.
Hot Engine: Crackling Noise Hot Smell Severe Local Hot Spots	A moderate amount of sound from heating metal can be expected with any vehicle. However, a crackling sound from the thermostat housing, a hot smell and/or severe local hot spots on an engine can indicate; blocked coolant passages, bad casting, core sand deposits and subsequent blockage, cracked cylinder block or head, or blown cylinder head gasket.
Coolant Reserve/ Overflow Tank Level Changes	Level changes are to be expected as coolant volume fluctuates with engine temperature. During operation at higher temperatures and/or under heavy loads, the coolant level in the reserve tank may increase above the FULL level indicated on the bottle. If the level in the tank is between the ADD and FULL marks when the engine is at normal operating temperature, the level should return to within that range when the engine returns to normal operating conditions.
Coolant Not Returning To Radiator	Coolant will not return to the radiator if the radiator cap vent valve does not function, if an air leak destroys vacuum, or if the overflow passage is blocked or restricted. Inspect all portions of the overflow passage, pressure cap, filler neck nipple, hose, and passages within the tank for vacuum leak only. Coolant return failure will be evident by a low level in the radiator. Reserve tank level should increase during heat-up.
4.0L Engine Only (XJ models): Electric Auxiliary Cooling Fan	The Fan will run when the air conditioning compressor is engaged regardless of coolant temperature. If fan runs when compressor is not engaged, and coolant temperature in the radiator outlet tank is below 88°C (190°F), Consult Group 8, Electrical Section.

SYSTEM DIAGNOSIS

Condition	Possible Cause	Correction
NOISE	<ul style="list-style-type: none"> (1) Fan contacting shroud. (2) Loose water pump impeller. (3) Glazed fan belt. (4) Loose fan belt. (5) Rough surface on drive pulley. (6) Water pump bearing worn. (7) Belt alignment. 	<ul style="list-style-type: none"> (1) Reposition shroud and inspect engine mounts. (2) Replace pump. (3) Replace belt. (4) Adjust fan belt tension. (5) Replace pulley. (6) Remove belt to isolate. Replace pump. (7) Check pulley alignment. Repair as necessary.
COOLANT LOSS— BOILOVER	<p>Refer to Overheating Causes in addition to the following items.</p> <ul style="list-style-type: none"> (1) Overfilled cooling system. (2) Quick shutdown after hard (hot) run. (3) Air in system, resulting in occasional "burping" of coolant. (4) Insufficient antifreeze, allowing coolant boiling point to be too low. (5) Antifreeze deteriorated because of age of contamination. (6) Leaks due to loose hose clamps, loose nuts, bolts, drain plugs, faulty hoses, or defective radiator. (7) Faulty head gasket. (8) Cracked head, manifold, or block. (9) Faulty radiator cap. 	<ul style="list-style-type: none"> (1) Reduce coolant level to proper specification. (2) Allow engine to run at fast idle prior to shutdown. (3) Purge system. (4) Add antifreeze to raise boiling point. (5) Replace coolant. (6) Pressure test system to locate source of leak(s), then repair as necessary. (7) Replace head gasket. (8) Replace as necessary. (9) Replace cap.
COOLANT ENTRY INTO CRANKCASE OR CYLINDER(S)	<ul style="list-style-type: none"> (1) Low cylinder head bolt torque. (2) Faulty head gasket. (3) Crack in head, manifold or block. 	<ul style="list-style-type: none"> (1) Replace gasket, retorque head. (2) Replace head gasket. (3) Replace as necessary.
COOLANT RESERVE SYSTEM INOPERATIVE	<ul style="list-style-type: none"> (1) Coolant level low. (2) Leak in system. (3) Overflow tube clogged or leaking. (4) Recovery bottle vent restricted. 	<ul style="list-style-type: none"> (1) Replenish coolant to FULL mark. (2) Pressure test to isolate leak and repair as necessary. (3) Repair as necessary. (4) Remove restriction.
LOW TEMPERATURE GAUGE INDICATION — UNDERCOOLING	<ul style="list-style-type: none"> (1) Thermostat stuck open. (2) Faulty gauge or sending unit. 	<ul style="list-style-type: none"> (1) Replace thermostat. (2) Repair or replace faulty component.

SYSTEM DIAGNOSIS (CONT.)

Condition	Possible Cause	Correction
HIGH TEMPERATURE GAUGE INDICATION — OVERHEATING	(1) Coolant level low. (2) Fan belt loose. (3) Radiator hose(s) collapsed. (4) Radiator airflow blocked. (5) Faulty coolant expansion bottle cap. (6) Air trapped in cooling system. (7) Heavy-traffic driving. (8) Incorrect cooling system component(s) installed. (9) Faulty thermostat. (10) Water pump shaft broken or impeller loose. (11) Radiator tubes clogged. (12) Cooling system clogged. (13) Casting flash in cooling passages. (14) Brakes dragging. (15) Excessive engine friction. (16) Antifreeze concentration over 68%. (17) Faulty gauge or sending unit. (18) Loss of coolant flow caused by leakage or foaming. (19) Faulty cooling fan operation.	(1) Replenish coolant. (2) Adjust fan belt tension. (3) Replace hose(s). (4) Remove restriction (bug screen, fog lamps, etc.). (5) Replace coolant expansion bottle cap. (6) Purge air. (7) Operate at fast idle in neutral intermittently to cool engine. (8) Install proper component(s). (9) Replace thermostat. (10) Replace water pump. (11) Flush radiator. (12) Flush system. (13) Repair or replace as necessary. Flash may be visible by removing cooling system components or removing core plugs. (14) Repair brakes. (15) Repair engine. (16) Lower antifreeze concentration percentage. (17) Repair or replace faulty component. (18) Repair or replace leaking component, replace coolant. (19) Check cooling fan operation.
NO COOLANT FLOW THROUGH HEATER CORE	(1) Restricted return inlet in water pump. (2) Heater hose collapsed or restricted. (3) Restricted heater core. (4) Restricted outlet in thermostat housing. (5) Intake manifold bypass hole in cylinder head restricted. (6) Intake manifold coolant passage restricted. (7) Heater valve controls not functioning. (8) Heater valve stuck in closed position.	(1) Remove restriction. (2) Remove restriction or replace hose. (3) Remove restriction or replace core. (4) Remove flash or restriction. (5) Remove restriction. (6) Remove restriction or replace intake manifold. (7) Repair controls (see Heating and Air Conditioning Group 24). (8) Repair or replace as necessary.

SERVICE PROCEDURES

INDEX

	page		page
Coolant	15	Refilling Cooling System	17
Coolant Reserve/Overflow System	19	Testing Cooling System for Leaks	18
Cooling System Cleaning/Reverse Flushing	17	Thermostat	13
Cooling System Fans	26	Transmission Oil Coolers	29
Cooling System Hoses	26	Water Pump Tests	9
Draining Cooling System	16	Water Pumps—General Information	9
Radiator Pressure Cap	20	Water Pumps—Removal/Installation	10
Radiators	22		

WATER PUMPS—GENERAL INFORMATION

A centrifugal water pump circulates coolant through the water jackets, passages, intake manifold, radiator core, cooling system hoses and heater core. The pump is driven from the engine crankshaft by a drive belt on all engines.

The water pump impeller is pressed onto the rear of a shaft that rotates in bearings pressed into the housing. The housing has a small hole to allow seepage to escape. The water pump seals are lubricated by the antifreeze in the coolant mixture. No additional lubrication is necessary.

CAUTION: All engines are equipped with a reverse (counter-clockwise) rotating water pump and viscous fan drive assembly. REVERSE is stamped or imprinted on the cover of the viscous fan drive and inner side of the fan. The letter R is stamped into the back of the water pump impeller (Fig. 1).

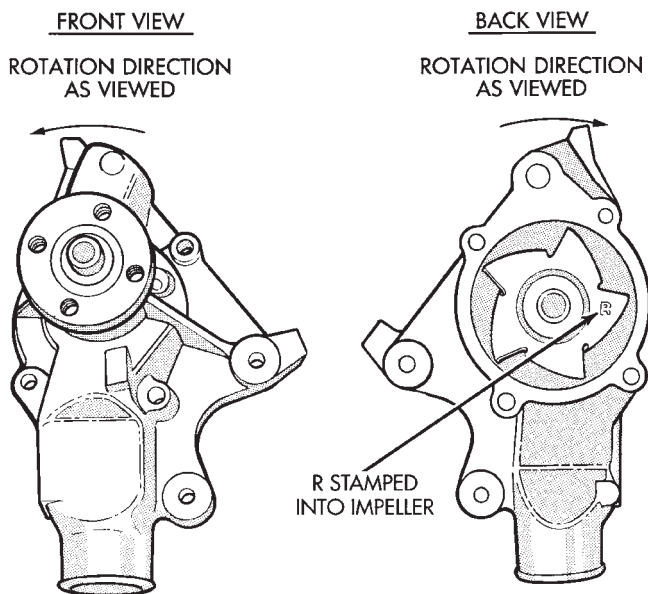

J9307-10

Fig. 1 Reverse Rotating Water Pump—Typical

Engines from previous model years, depending upon application, may have been equipped with a forward (clockwise) rotating water pump. Installation of the wrong water pump will cause engine overheating.

A quick test to determine if the pump is working is to check if the heater warms properly. A defective water pump will not be able to circulate heated coolant through the long heater hose to the heater core.

WATER PUMP TESTS

LOOSE IMPELLER

DO NOT WASTE reusable coolant. If solution is clean, drain coolant into a clean container for reuse.

WARNING: DO NOT REMOVE THE CYLINDER BLOCK DRAIN PLUGS OR LOOSEN THE RADIATOR DRAINCOCK WITH THE SYSTEM HOT AND UNDER PRESSURE. SERIOUS BURNS FROM THE COOLANT CAN OCCUR.

- (1) Drain the cooling system.
- (2) Loosen the fan belt(s).
- (3) Disconnect the lower radiator hose from the water pump.
- (4) Bend a stiff clothes hanger or welding rod as shown in (Fig. 2).
- (5) Position the rod in the water pump inlet and attempt to hold the impeller while turning the fan blades. If equipped with a viscous fan drive, turn the water pump shaft with a breaker bar and socket attached to a mounting flange nut. If the impeller is loose and can be held with the rod while the fan blades are turning, the pump is defective. If the impeller turns, the pump is OK.

Connect the hose and install the coolant, or proceed with repairs.

INSPECTING FOR INLET RESTRICTIONS

Inadequate heater performance may be caused by a metal casting restriction in the water pump heater hose inlet.

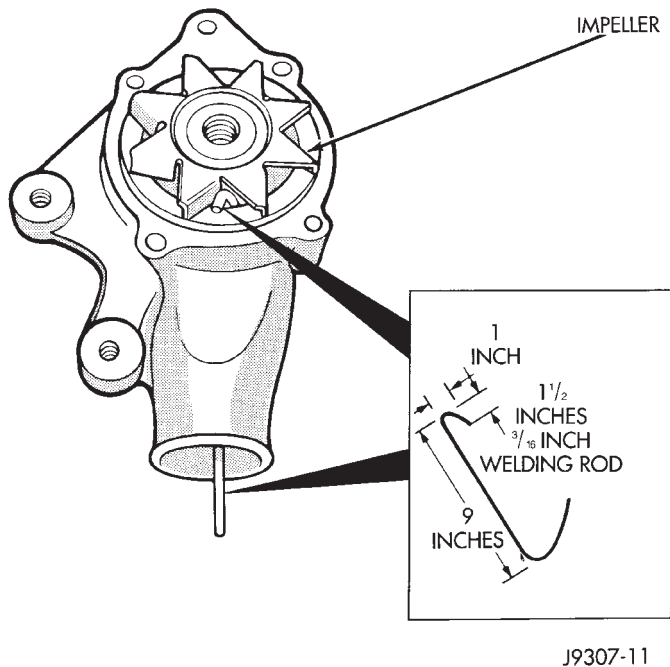

J9307-11

Fig. 2 Impeller Test—Typical

DO NOT WASTE reusable coolant. If solution is clean, drain coolant into a clean container for reuse.

WARNING: DO NOT REMOVE THE CYLINDER BLOCK DRAIN PLUGS OR LOOSEN THE RADIATOR DRAINCOCK WITH THE SYSTEM HOT AND UNDER PRESSURE. SERIOUS BURNS FROM THE COOLANT CAN OCCUR.

(1) Drain sufficient coolant from the radiator to decrease the level below the water pump heater hose inlet.

(2) Remove the heater hose.

(3) Inspect the inlet for metal casting flash or other restrictions.

Remove the pump from engine before removing restriction to prevent contamination of the coolant with debris. Refer to Water Pump Removal.

WATER PUMPS—REMOVAL/INSTALLATION

REMOVAL—ALL MODELS

The water pump on all models can be removed without discharging the air conditioning system (if equipped).

CAUTION: All engines have a reverse (counterclockwise) rotating water pump. The letter R is stamped into the back of the water pump impeller (Fig. 1) to identify. Engines from previous model years, depending upon application, may be equipped with a forward (clockwise) rotating water pump. Installation of the wrong water pump will cause engine over heating.

The water pump impeller is pressed on the rear of the pump shaft and bearing assembly. The water pump is serviced only as a complete assembly.

WARNING: DO NOT REMOVE THE BLOCK DRAIN PLUG(S) OR LOOSEN RADIATOR DRAINCOCK WITH THE SYSTEM HOT AND UNDER PRESSURE. SERIOUS BURNS FROM COOLANT CAN OCCUR.

DO NOT WASTE reusable coolant. If the solution is clean, drain coolant into a clean container for reuse.

(1) Disconnect negative battery cable at battery.

(2) Drain the cooling system. Refer to Draining Cooling System in this group.

(3) **XJ models with 4.0L engine equipped with A/C or heavy duty cooling system:**

Loosen (but do not remove at this time) the four water pump pulley-to-water pump hub mounting bolts (Fig. 3).

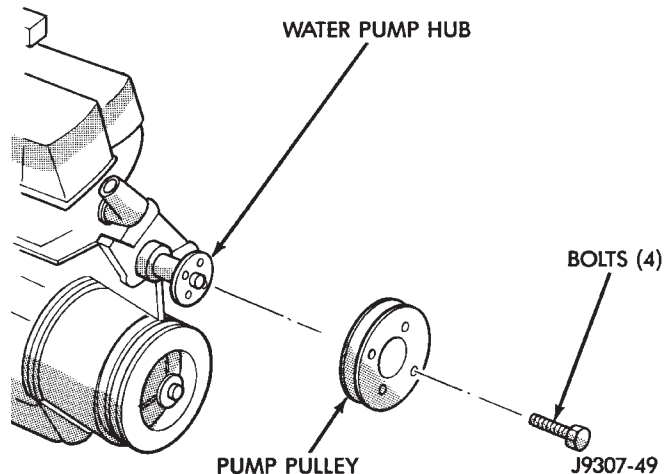

Fig. 3 Water Pump Pulley Bolts

XJ models with 4.0L engine without A/C or heavy duty cooling system; or any 2.5L engines; or any YJ models:

Loosen (but do not remove at this time) the four fan hub-to-water pump pulley mounting nuts (Fig. 4).

The engine accessory drive belt must be removed prior to removing the fan (if installed at pump) or fan pulley.

(4) Remove engine drive belt as follows:

(a) Loosen two rear power steering pump mounting bolts A (Fig. 5).

(b) Loosen upper pump pivot bolt B and lower lock nut C (Figs. 6 or 7).

(c) Loosen pump adjusting bolt D (Fig. 5) until belt can be removed.

(d) Remove belt.

(5) Check condition of all pulleys.

(6) The power steering pump must be removed from its cast mounting bracket to gain access to bolt

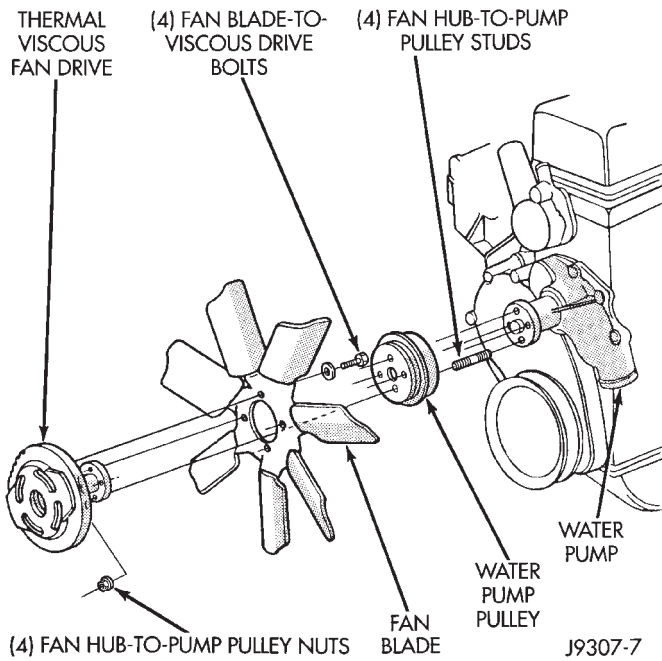

Fig. 4 Fan Mounting Nuts

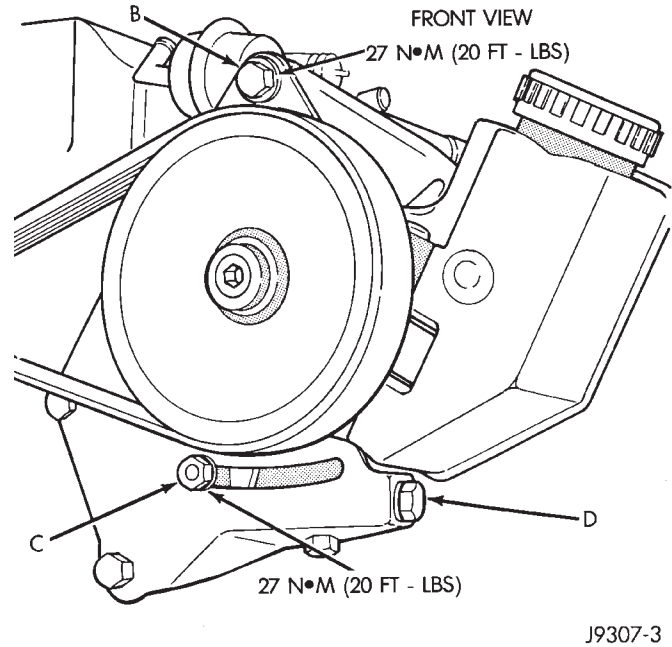

Fig. 6 P.S. Pump Front Mounting Bolt/Locknut—Typical

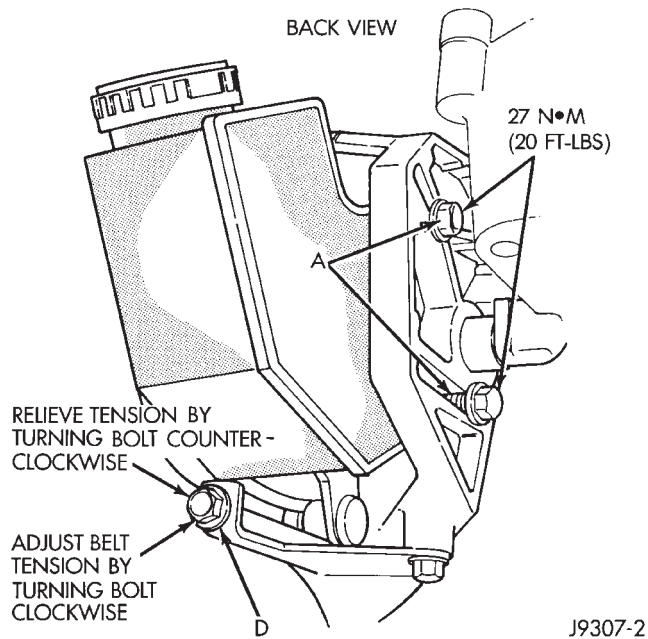

Fig. 5 P.S. Pump Rear Mounting Bolts—Typical

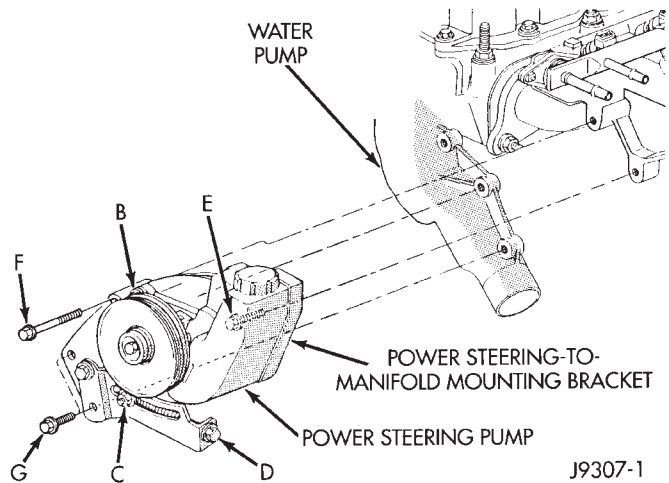

Fig. 7 Bracket Mounting Bolts—Typical

E. Bracket mounting bolt E is located behind the power steering pump (Fig. 7).

(7) Remove two bolts A (Fig. 5).

(8) Remove locknut C and belt adjustment bolt D (Figs. 6 or 7).

(9) Remove bolt B (Fig. 6). Position power steering pump to the side. Hold pump in position with wire. Do not disconnect hydraulic lines from pump.

(10) Remove bolts E, F and G (Fig. 7) and remove pump mounting bracket.

(11) Remove idler pulley mounting bolt and remove idler pulley. This must be done to gain clearance for the water pump mounted heater hose fitting when water pump is being removed. Note position of pulley spacers after removal.

WARNING: CONSTANT TENSION HOSE CLAMPS ARE USED ON MOST COOLING SYSTEM HOSES. WHEN REMOVING OR INSTALLING, USE ONLY TOOLS DESIGNED FOR SERVICING THIS TYPE OF CLAMP, SUCH AS SPECIAL CLAMP TOOL (NUMBER 6094) (FIG. 8). SNAP-ON CLAMP TOOL (NUMBER HPC-20) MAY BE USED FOR LARGER CLAMPS. ALWAYS WEAR SAFETY GLASSES WHEN SERVICING CONSTANT TENSION CLAMPS.

CAUTION: A number or letter is stamped into the tongue of constant tension clamps. If replacement is necessary, use only an original equipment clamp with matching number or letter.

(12) Remove lower radiator hose from water pump. Remove heater hose from water pump fitting.

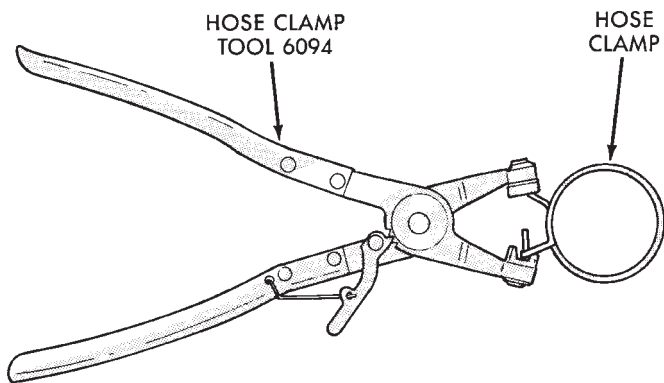

J9207-36

Fig. 8 Hose Clamp Tool—Typical

(13) Remove four nuts or bolts (refer to the previous step #3).

(14) Remove the fan assembly and pulley (if fan is installed at pump), or remove the pulley from the vehicle.

(15) Remove the four pump mounting bolts (Fig. 9) and remove pump from vehicle. Discard old gasket. Note that one of the four bolts is longer than the other bolts.

(16) If pump is to be replaced, the heater hose fitting must be removed. Note position of fitting before removal.

INSTALLATION—ALL MODELS

(1) If pump is being replaced, install the heater hose fitting to the pump. Use a sealant on the fitting such as Mopar™ Thread Sealant With Teflon. Refer to the directions on the package.

(2) Clean the gasket mating surfaces. If the original pump is used, remove any deposits or other foreign material. Inspect the cylinder block and water pump mating surfaces for erosion or damage from cavitation.

(3) Install the gasket and water pump (the gasket is installed dry). Tighten mounting bolts to 30 N·m (22 ft. lbs.) torque. Rotate the shaft by hand to be sure it turns freely.

(4) Connect the radiator and heater hoses to the water pump.

(5) Position water pump pulley to water pump hub.

(6) If equipped with a water pump mounted fan, install fan and four nuts to water pump hub. If not

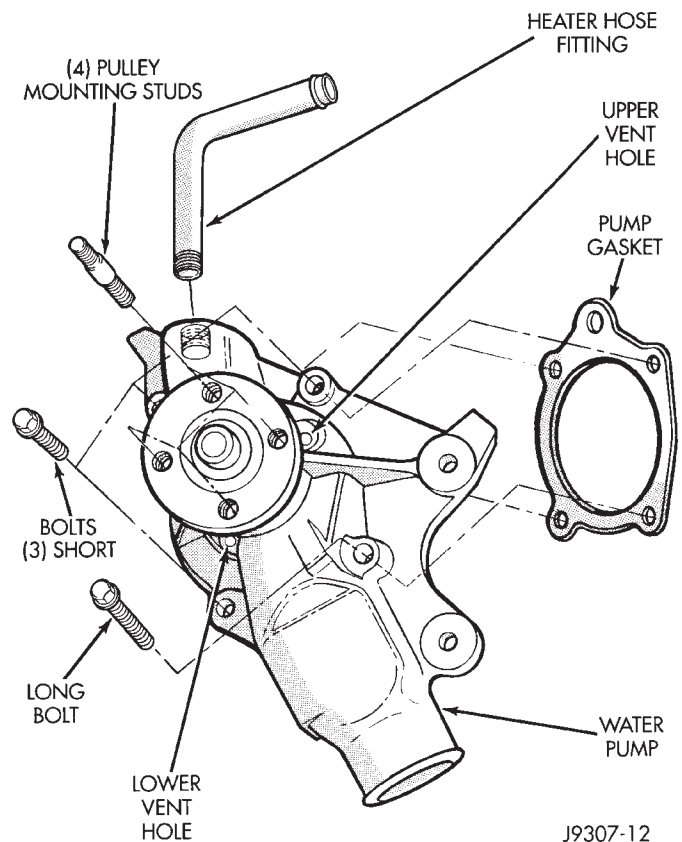

J9307-12

Fig. 9 Water Pump Remove/Install—Typical

equipped with a water pump mounted fan, install four pump hub bolts. Tighten bolts (or nuts) to 27 N·m (20 ft. lbs.) torque.

(7) Position power steering pump bracket to engine. Install bolts E, F and G (Fig. 7). Tighten bolts F and G to 38 N·m (28 ft. lbs.) torque. Tighten bolt E to 27 N·m (20 ft. lbs.) torque.

(8) Position power steering pump to mounting bracket. Install pivot bolt B (Fig. 6) finger tight. Install locknut C and adjustment bolt D (Figs. 6 or 7) finger tight.

(9) Install two adjustment bolts A (Fig. 6) finger tight.

(10) Install idler pulley.

CAUTION: When installing the serpentine engine accessory drive belt, the belt **MUST** be routed correctly. If not, the engine may overheat due to the water pump rotating in the wrong direction. Refer to Figs. 10, 11, 12 or 13 for appropriate belt routing. You may also refer to the Belt Routing Label in the vehicle engine compartment.

(11) Position drive belt to pulleys.

(12) Tighten belt adjustment bolt D (Fig. 5) to the proper tension. Refer to the Specifications section at the end of this group for belt tension.

(13) Tighten bolts A (Fig. 5) to 27 N·m (20 ft. lbs.) torque.

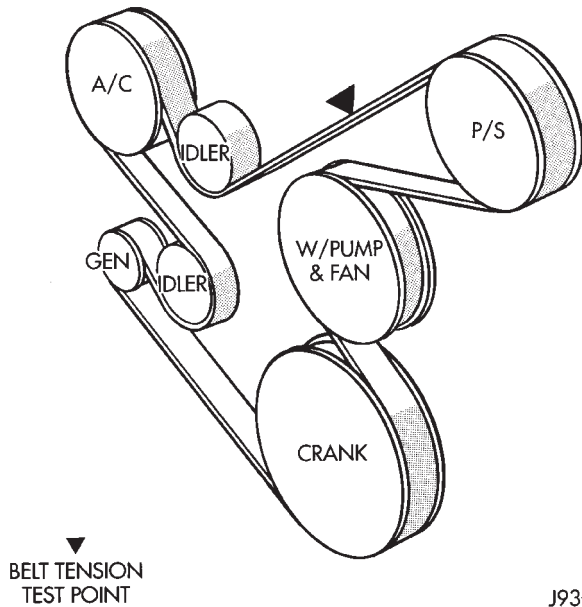

Fig. 10 YJ Models with 4.0L Engine and XJ Models with 2.5L Engine—With A/C

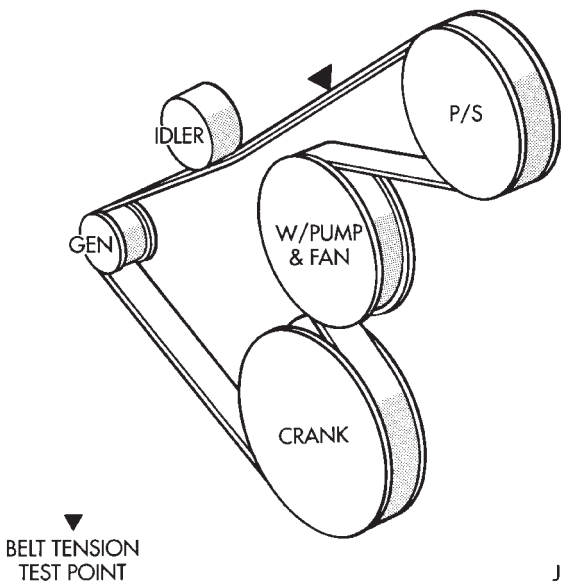

Fig. 11 YJ Models With 2.5L or 4.0L Engine and XJ Models with 2.5L Engine—Without A/C

- (14) Tighten pivot bolt B (Fig. 6) to 27 N·m (20 ft. lbs.) torque.
- (15) Tighten locknut C (Fig. 6) to 27 N·m (20 ft. lbs.) torque.
- (16) After the power steering pump has been tightened, recheck belt tension.
- (17) Fill cooling system with coolant and check for leaks. Refer to Refilling Cooling System in this group.
- (18) Connect battery cable to battery.
- (19) Start and warm the engine. Check for leaks.

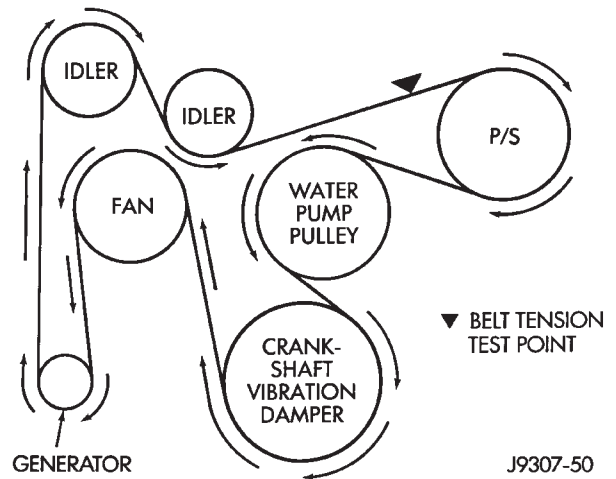

Fig. 12 XJ Models with 4.0L Engine—Without A/C

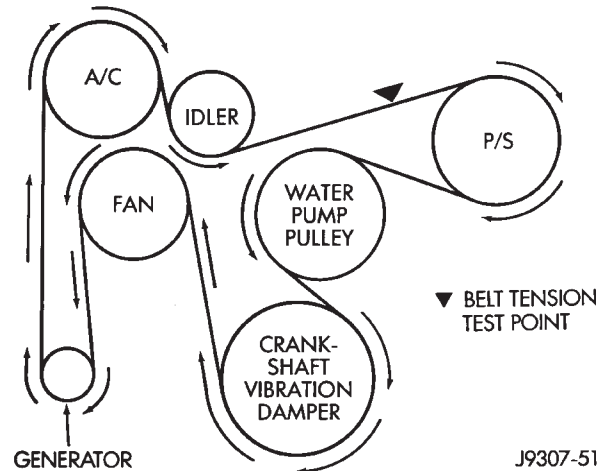

Fig. 13 XJ Models With 4.0L Engine—With A/C THERMOSTAT

DESCRIPTION AND OPERATION

A pellet-type thermostat controls the operating temperature of the engine by controlling the amount of coolant flow to the radiator. On all engines the thermostat is closed below 195°F (90°C). Above this temperature, coolant is allowed to flow to the radiator. This provides quick engine warmup and overall temperature control.

An arrow plus the word **UP** is stamped on the front flange next to the air bleed. The words **TO RAD** are stamped on one arm of the thermostat. They indicate the proper installed position.

The same thermostat is used for winter and summer seasons. An engine should not be operated without a thermostat, except for servicing or testing. Operating without a thermostat causes other problems. These are: longer engine warmup time, unreliable warmup performance, increased exhaust emissions and crankcase condensation. This condensation can result in sludge formation.

CAUTION: Do not operate an engine without a thermostat, except for servicing or testing.

ON-BOARD DIAGNOSTICS

XJ and YJ models are equipped with On-Board Diagnostics for certain cooling system components. Refer to On-Board Diagnostics (OBD) in the Diagnosis section of this group for additional information. If the powertrain control module (PCM) detects low engine coolant temperature, it will record a Diagnostic Trouble Code (DTC) in the PCM memory. The DTC number for low coolant temperature is 17. Do not change a thermostat for lack of heat as indicated by the instrument panel gauge or heater performance unless a DTC number 17 is present. Refer to the Diagnosis section of this group for other probable causes. For other DTC numbers, refer to On-Board Diagnostics in the General Diagnosis section of group 14, Fuel Systems.

The DTC can also be accessed through the DRB scan tool. Refer to the appropriate Powertrain Diagnostic Procedures manual for diagnostic information and operation of the DRB scan tool.

REMOVAL

WARNING: DO NOT LOOSEN THE RADIATOR DRAINCOCK WITH THE SYSTEM HOT AND PRESSURIZED. SERIOUS BURNS FROM THE COOLANT CAN OCCUR.

DO NOT WASTE reusable coolant. If the solution is clean, drain the coolant into a clean container for reuse.

(1) Drain the coolant from the radiator until the level is below the thermostat housing.

WARNING: CONSTANT TENSION HOSE CLAMPS ARE USED ON MOST COOLING SYSTEM HOSES. WHEN REMOVING OR INSTALLING, USE ONLY TOOLS DESIGNED FOR SERVICING THIS TYPE OF CLAMP, SUCH AS SPECIAL CLAMP TOOL (NUMBER 6094) (FIG. 14). SNAP-ON CLAMP TOOL (NUMBER HPC-20) MAY BE USED FOR LARGER CLAMPS. ALWAYS WEAR SAFETY GLASSES WHEN SERVICING CONSTANT TENSION CLAMPS.

CAUTION: A number or letter is stamped into the tongue of constant tension clamps. If replacement is necessary, use only an original equipment clamp with matching number or letter.

(2) Remove radiator upper hose and heater hose at thermostat housing.

(3) Disconnect wiring connector at engine coolant temperature sensor.

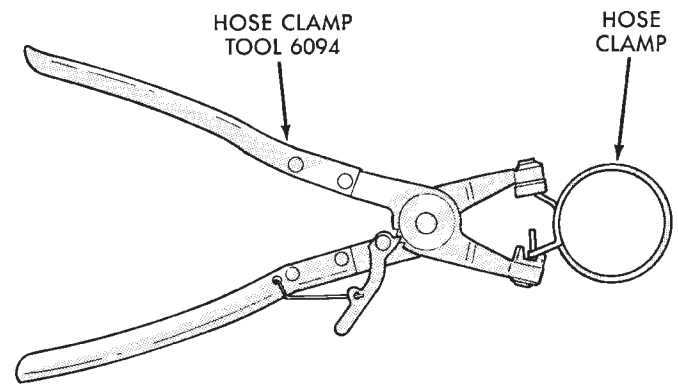

J9207-36

Fig. 14 Hose Clamp Tool—Typical

(4) Remove thermostat housing mounting bolts, thermostat housing, gasket and thermostat (Fig. 15). Discard old gasket.

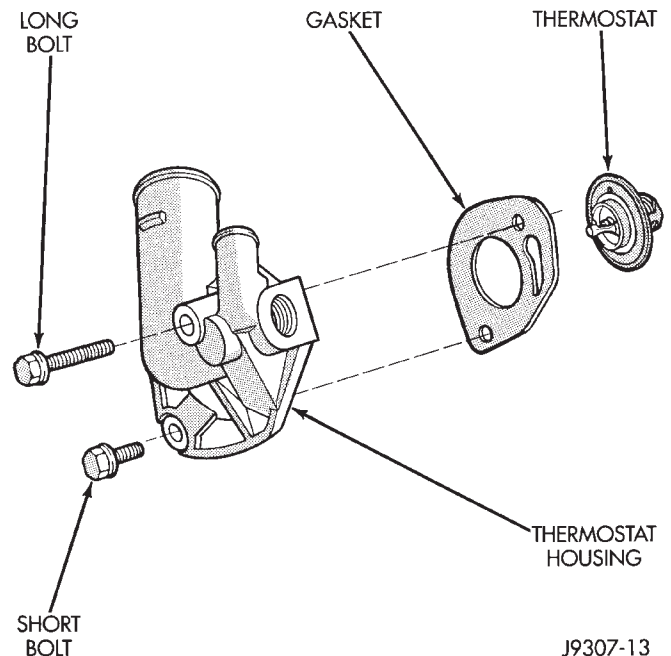

J9307-13

Fig. 15 Thermostat Removal/Installation

(5) Clean the gasket mating surfaces.

INSTALLATION

(1) Install the replacement thermostat so that the pellet, which is encircled by a coil spring, faces the engine. All thermostats are marked on the outer flange to indicate the proper installed position.

(a) Observe the recess groove in the engine cylinder head (Fig. 16).

(b) Position thermostat in groove with arrow and air bleed hole on outer flange pointing up.

(2) Install replacement gasket and thermostat housing.

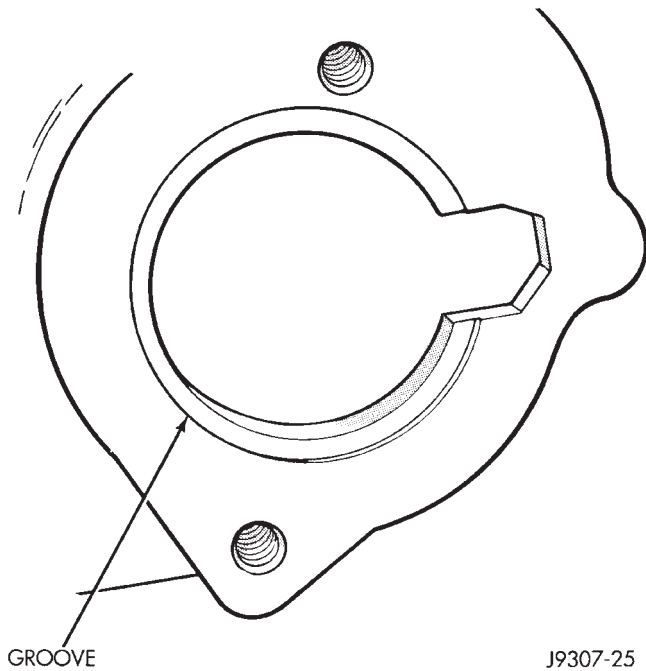

Fig. 16 Thermostat Recess

CAUTION: Tightening the thermostat housing unevenly or with the thermostat out of its recess, may result in a cracked housing.

- (3) Tighten the housing bolts to 20 N·m (15 ft. lbs.) torque.
- (4) Install hoses to thermostat housing.
- (5) Install electrical connector to coolant temperature sensor.
- (6) Be sure that the radiator draincock is tightly closed. Fill the cooling system to the correct level with the required coolant mixture. Refer to Refilling Cooling System in this group.
- (7) Start and warm the engine. Check for leaks.

COOLANT

GENERAL INFORMATION

The cooling system is designed around the coolant. Coolant flows through the engine water jackets absorbing heat produced during engine operation. The coolant carries heat to the radiator and heater core. Here it is transferred to the ambient air passing through the radiator and heater core fins. The coolant also removes heat from the automatic transmission fluid in vehicles equipped with an automatic transmission.

COOLANT PERFORMANCE

The required ethylene-glycol (antifreeze) and water mixture depends upon climate and vehicle operating conditions. The coolant performance of various mixtures follows:

Pure Water-Water can absorb more heat than a mixture of water and ethylene-glycol. This is for pur-

pose of heat transfer only. Water also freezes at a higher temperature and allows corrosion.

100 percent Ethylene-Glycol-The corrosion inhibiting additives in ethylene-glycol need the presence of water to dissolve. Without water, additives form deposits in system. These act as insulation causing temperature to rise to as high as 149°C (300°F). This temperature is hot enough to melt plastic and soften solder. The increased temperature can result in engine detonation. In addition, 100 percent ethylene-glycol freezes at -22°C (-8°F).

50/50 Ethylene-Glycol and Water-Is the recommended mixture, it provides protection against freezing to -37°C (-35°F). The antifreeze concentration **must always** be a minimum of 44 percent, year-round in all climates. If percentage is lower, engine parts may be eroded by cavitation. Maximum protection against freezing is provided with a 68 percent antifreeze concentration, which prevents freezing down to -67.7°C (-90°F). A higher percentage will freeze at a warmer temperature. Also, a higher percentage of antifreeze can cause the engine to overheat because specific heat of antifreeze is lower than that of water.

CAUTION: Richer antifreeze mixtures cannot be measured with normal field equipment and can cause problems associated with 100 percent ethylene-glycol.

COOLANT SELECTION-ADDITIVES

Coolant should be maintained at the specified level with a mixture of ethylene glycol-based antifreeze and low mineral content water. Only use an antifreeze containing ALUGARD 340-2™.

CAUTION: Do not use coolant additives that are claimed to improve engine cooling.

COOLANT SERVICE

It is recommended that the cooling system be drained and flushed at 84,000 kilometers (52,500 miles), or 3 years, whichever occurs first. Then every two years, or 48,000 kilometers (30,000 miles), whichever occurs first.

COOLANT LEVEL CHECK—ROUTINE

Do not remove radiator cap for routine coolant level inspections. The coolant level can be checked at coolant reserve/overflow tank.

The coolant reserve/overflow system provides a quick visual method for determining coolant level without removing radiator pressure cap. With engine idling and at normal operating temperature, observe coolant level in reserve/overflow tank. The coolant level should be between ADD and FULL marks.

ADDING ADDITIONAL COOLANT—ROUTINE

Do not remove radiator cap to add coolant to system. When adding coolant to maintain correct level, do so at coolant reserve/overflow tank. Use a 50/50 mixture of ethylene-glycol antifreeze containing Alugard 340-2™ and low mineral content water. Remove radiator cap only for testing or when refilling system after service. Removing cap unnecessarily can cause loss of coolant and allow air to enter system, which produces corrosion.

COOLANT LEVEL CHECK-SERVICE

The cooling system is closed and designed to maintain coolant level to top of radiator.

WARNING: DO NOT OPEN RADIATOR DRAINCOCK WITH ENGINE RUNNING OR WHILE ENGINE IS HOT AND COOLING SYSTEM IS UNDER PRESSURE.

When vehicle servicing requires a coolant level check in radiator, drain several ounces of coolant from radiator drain cock. Do this while observing coolant reserve/overflow system tank. The coolant level in reserve/overflow tank should drop slightly. If not, inspect for a leak between radiator and coolant reserve/overflow system connection. Remove radiator cap. The coolant level should be to top of radiator. If not and if coolant level in reserve/overflow tank is at ADD mark, check for:

- An air leak in coolant reserve/overflow tank or its hose
- An air leak in radiator filler neck
- Leak in pressure cap seal to radiator filler neck

LOW COOLANT LEVEL-AERATION

If the coolant level in radiator drops below top of radiator core tubes, air will enter cooling system.

Low coolant level can cause thermostat pellet to be suspended in air instead of coolant. This will cause thermostat to open later, which in turn causes higher coolant temperature. Air trapped in cooling system also reduces amount of coolant circulating in heater core resulting in low heat output.

DEAERATION

As the engine operates, any air trapped in cooling system gathers under the radiator cap. The next time the engine is operated, thermal expansion of coolant will push any trapped air past radiator cap into the coolant reserve/overflow tank. Here it escapes to the atmosphere into the tank. When the engine cools down the coolant, it will be drawn from the reserve/overflow tank into the radiator to replace any removed air.

DRAINING COOLING SYSTEM

ALL MODELS—EXCEPT XJ WITH 4.0L ENGINE

WARNING: DO NOT REMOVE THE CYLINDER BLOCK DRAIN PLUGS OR LOOSEN THE RADIATOR DRAINCOCK WITH SYSTEM HOT AND UNDER PRESSURE. SERIOUS BURNS FROM COOLANT CAN OCCUR.

DO NOT WASTE reusable coolant. If the solution is clean, drain the coolant into a clean container for reuse.

DO NOT remove the radiator cap when draining the coolant from the reserve/overflow tank. Open the radiator draincock and when the tank is empty, remove the radiator cap. The coolant does not have to be removed from the tank unless the system is being refilled with a fresh mixture.

(1) Drain the coolant from the radiator by loosening the draincock.

(2) Drain coolant from engine as follows:

(a) On 2.5L engines (all models) by removing drain plug at left rear side of block.

(b) On 4.0L engines by removing the drain plug or coolant temperature sensor on the left side of the block (Fig. 17).

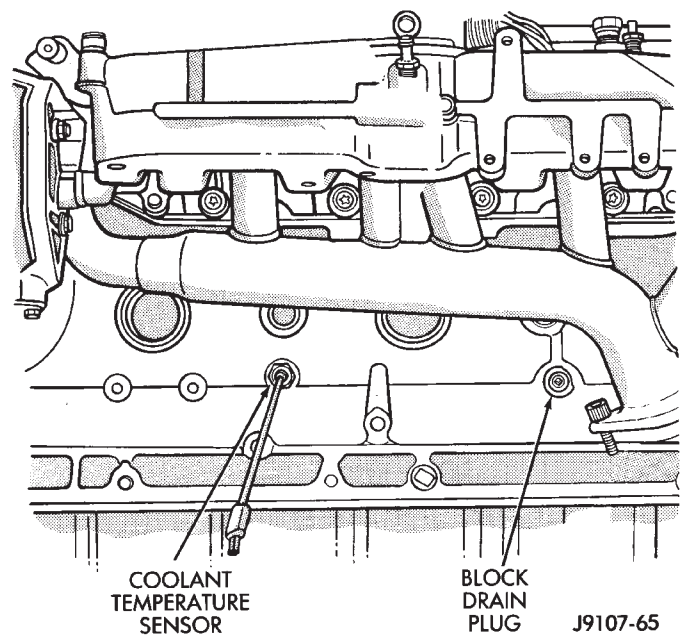

Fig. 17 Draining Coolant—4.0L Engine

XJ MODELS WITH 4.0L ENGINE

WARNING: DO NOT REMOVE THE CYLINDER BLOCK DRAIN PLUGS OR LOOSEN THE RADIATOR DRAINCOCK WITH SYSTEM HOT AND UNDER PRESSURE. SERIOUS BURNS FROM COOLANT CAN OCCUR.

DO NOT WASTE reusable coolant. If the solution is clean, drain the coolant into a clean container for reuse.

- (1) Remove radiator pressure cap.
- (2) For access to radiator draincock, remove radiator grille (Fig. 18).

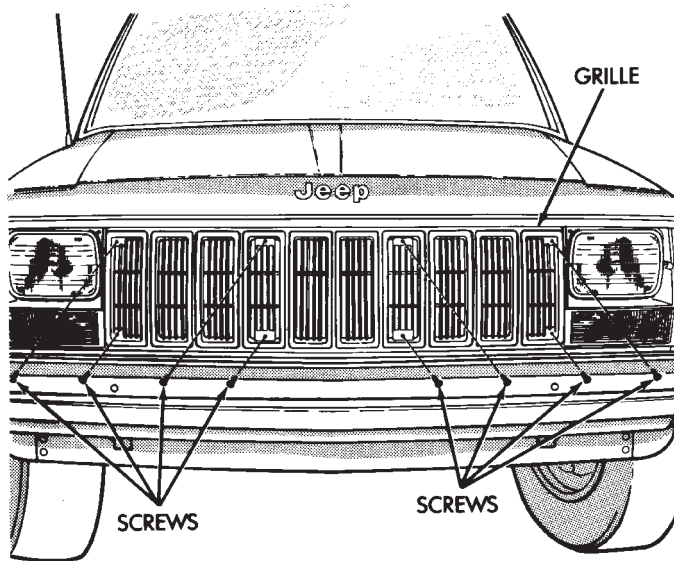

J8907-19

Fig. 18 Draincock Access—XJ Models with 4.0L Engine

(3) Attach one end of a 24 inch long X 1/4 inch ID hose to the radiator draincock. Put the other end into a clean container. Open draincock and drain coolant from radiator.

(4) Drain coolant from engine by removing the drain plug and coolant temperature sensor on left side of block (Fig. 17).

REFILLING COOLING SYSTEM

YJ MODELS

(1) Remove draining hose. Tighten the radiator draincock and the cylinder block drain plug(s).

(2) Fill system using a 50/50 mixture of water and antifreeze. This is described in the Coolant section of this group. Fill the radiator to the top and install the radiator cap. Add sufficient coolant to the reserve/overflow tank to raise the level to the FULL mark.

(3) Operate the engine with the radiator cap and reserve/overflow tank cap in place. After the engine has reached the normal operating temperature, shut the engine off and allow it to cool.

(4) Add coolant to the reserve/overflow tank as necessary. **Only add coolant when the engine is cold. Coolant level in a warm engine will be higher due to thermal expansion.**

XJ MODELS

(1) Tighten the radiator draincock and the cylinder block drain plug(s). If removed, install coolant temperature sensor (4.0L engine).

(2) Fill system using a 50/50 mixture of water and antifreeze as described in the Coolant section of this group. Fill radiator to top and install radiator cap. Add sufficient coolant to reserve/overflow tank to raise level to FULL mark.

(3) With heater control unit in the HEAT position, operate engine with radiator cap in place.

(4) After engine has reached normal operating temperature, shut engine off and allow it to cool.

(5) Add coolant to reserve/overflow tank as necessary. **Only add coolant when the engine is cold. Coolant level in a warm engine will be higher due to thermal expansion.**

COOLING SYSTEM CLEANING/REVERSE FLUSHING

CAUTION: The cooling system normally operates at 97-to-124 kPa (14-to-18 psi) pressure. Exceeding this pressure may damage the radiator or hoses.

CLEANING

Drain cooling system and refill with water. Run engine with radiator cap installed until upper radiator hose is hot. Stop engine and drain water from system. If water is dirty, fill system with water, run engine and drain system. Repeat until water drains clean.

REVERSE FLUSHING

Reverse flushing of the cooling system is the forcing of water through the cooling system. This is done using air pressure in the opposite direction of normal coolant flow. It is usually only necessary with very dirty systems with evidence of partial plugging.

REVERSE FLUSHING RADIATOR

Disconnect the radiator hoses from the radiator fittings. Attach a section of radiator hose to the radiator bottom outlet fitting and insert the flushing gun. Connect a water supply hose and air supply hose to the flushing gun.

CAUTION: The cooling system normally operates at 97-to-124 kPa (14-to-18 psi) pressure. Exceeding this pressure may damage the radiator or hoses.

Allow the radiator to fill with water. When radiator is filled, apply air in short blasts allowing radiator to refill between blasts. Continue this reverse flushing until clean water flows out through rear of radiator cooling tube passages. For more information, refer to operating instructions supplied with flushing equipment. Have radiator cleaned more extensively by a radiator repair shop.

REVERSE FLUSHING ENGINE

Drain the cooling system. Remove the thermostat housing and thermostat. Install the thermostat housing. Disconnect the radiator upper hose from the radiator and attach the flushing gun to the hose. Disconnect the radiator lower hose from the water pump. Attach a lead away hose to the water pump inlet fitting.

CAUTION: On XJ models, be sure that the heater control valve is closed (heat off). This is done to prevent coolant flow with scale and other deposits from entering the heater core.

Connect the water supply hose and air supply hose to the flushing gun. Allow the engine to fill with water. When the engine is filled, apply air in short blasts, allowing the system to fill between air blasts. Continue until clean water flows through the lead away hose. For more information, refer to operating instructions supplied with flushing equipment.

Remove the lead away hose, flushing gun, water supply hose and air supply hose. Remove the thermostat housing and install thermostat. Install the thermostat housing with a replacement gasket. Refer to Thermostat Replacement. Connect the radiator hoses. Refill the cooling system with the correct antifreeze/water mixture.

CHEMICAL CLEANING

In some instances, use a radiator cleaner (Mopar Radiator Kleen or equivalent) before flushing. This will soften scale and other deposits and aid the flushing operation.

CAUTION: Be sure instructions on the container are followed.

TESTING COOLING SYSTEM FOR LEAKS

ULTRAVIOLET LIGHT METHOD

All Jeep™ models have a leak detection additive added to the cooling system before they leave the factory. The additive is highly visible under ultraviolet light (black light). If the factory original coolant has been drained, pour one ounce of additive into the cooling system. The additive is available through the part's department. Place the heater control unit in HEAT position. Start and operate the engine until the radiator upper hose is warm to the touch. Aim the black light (tool 7138 or an equivalent), at the components to be checked. If leaks are present, the black light will cause the additive to glow a bright green color.

The black light can be used along with a pressure tester to determine if any external leaks exist (Fig. 19).

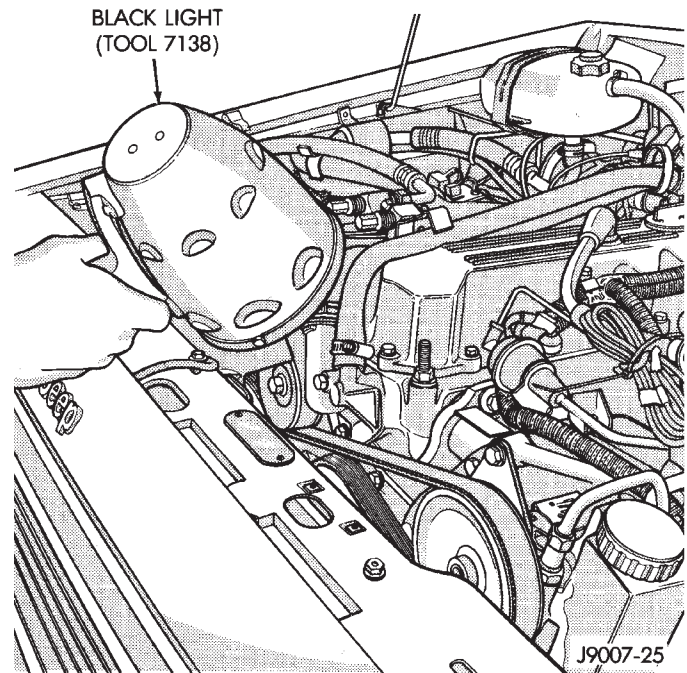

Fig. 19 Leak Detection Using Black Light—Typical PRESSURE TESTER METHOD

The engine should be at the normal operating temperature. Recheck the system cold if the cause of coolant loss is not located during warm engine examination.

WARNING: HOT, PRESSURIZED COOLANT CAN CAUSE INJURY BY SCALDING.

Carefully remove the radiator pressure cap from the filler neck and check the coolant level. Push down on the cap to disengage it from the stop tabs. Wipe the inner part of the filler neck and examine the lower inside sealing seat for nicks, cracks, paint, dirt and solder residue. Inspect the reserve/overflow tank tube for internal obstructions. Insert a wire through the tube to be sure it is not obstructed.

Inspect the cams on the outside part of the filler neck. If the cams are bent, seating of pressure cap valve and tester seal will be affected. Bent cams can be reformed if done carefully. Attach pressure tester 7700 or an equivalent to the radiator filler neck (Fig. 20).

Operate the tester pump to apply 124 kPa (18 psi) pressure to the system. If the hoses enlarge excessively or bulge while testing, replace as necessary. Observe the gauge pointer and determine the condition of the cooling system according to the following criteria:

- **Holds Steady:** If the pointer remains steady for two minutes, there are no serious coolant leaks in the system. However, there could be an internal leak that does not appear with normal system test pressure. Inspect for interior leakage or do the Internal

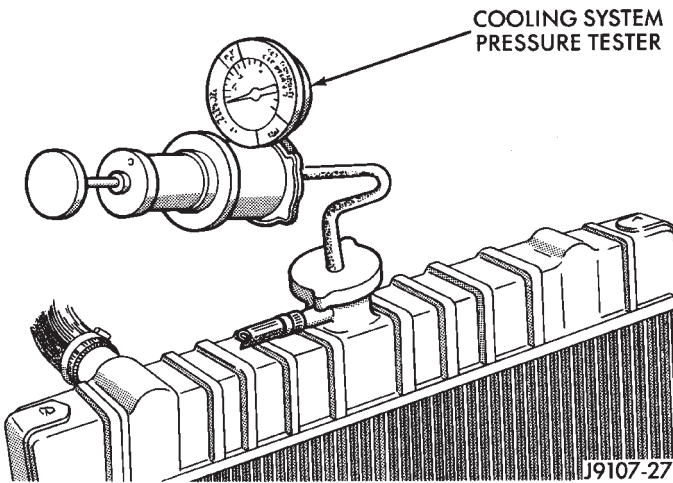

Fig. 20 Pressurizing System—Typical

Leakage Test. Do this if it is certain that coolant is being lost and no leaks can be detected.

- **Drops Slowly:** Shows a small leak or seepage is occurring. Examine all connections for seepage or slight leakage with a flashlight. Inspect the radiator, hoses, gasket edges and heater. Seal any small leak holes with a Sealer Lubricant or equivalent. Repair leak holes and reinspect the system with pressure applied.
- **Drops Quickly:** Shows that a serious leakage is occurring. Examine the system for serious external leakage. If no leaks are visible, inspect for internal leakage. Large radiator leak holes should be repaired by a reputable radiator repair shop.

INTERNAL LEAKAGE INSPECTION

Remove the oil pan drain plug and drain a small amount of engine oil. Coolant, being heavier will drain first, or operate engine to churn oil, then examine dipstick for water globules. Inspect the transmission dipstick for water globules. Inspect the transmission fluid cooler for leakage. Operate the engine without the pressure cap on the radiator until thermostat opens.

Attach a Pressure Tester to the filler neck. If pressure builds up quickly, a leak exists as result of a faulty cylinder head gasket or crack in the engine. Repair as necessary.

WARNING: DO NOT ALLOW PRESSURE TO EXCEED 124 KPA (18 PSI). TURN THE ENGINE OFF. TO RELEASE THE PRESSURE, ROCK THE TESTER FROM SIDE TO SIDE. WHEN REMOVING THE TESTER, DO NOT TURN THE TESTER MORE THAN 1/2 TURN IF THE SYSTEM IS UNDER PRESSURE.

If there is no immediate pressure increase, pump the Pressure Tester until the indicated pressure is within the system range. Vibration of the gauge pointer indicates compression or combustion leakage into the cooling system.

WARNING: DO NOT DISCONNECT THE SPARK PLUG WIRES WHILE THE ENGINE IS OPERATING.

CAUTION: Do not operate the engine with a spark plug shorted for more than a minute. The catalytic converter may be damaged.

Isolate the compression leak by shorting each spark plug to the cylinder block. The gauge pointer should stop or decrease vibration when spark plug for leaking cylinder is shorted. This happens because of the absence of combustion pressure.

COMBUSTION LEAKAGE TEST (WITHOUT PRESSURE TESTER)

DO NOT WASTE reusable coolant. If the solution is clean, drain the coolant into a clean container for reuse.

WARNING: DO NOT REMOVE THE CYLINDER BLOCK DRAIN PLUGS OR LOOSEN THE RADIATOR DRAINCOCK WITH THE SYSTEM HOT AND UNDER PRESSURE. SERIOUS BURNS FROM COOLANT CAN OCCUR.

Drain sufficient coolant to allow for thermostat removal. Refer to Thermostat Replacement. Disconnect the water pump drive belt.

Disconnect the upper radiator hose from the thermostat housing. Remove the housing and thermostat. Install the thermostat housing.

Add coolant to the radiator to bring the level to within 6.3 mm (1/4 in) of the top of the thermostat housing.

CAUTION: Avoid overheating. Do not operate the engine for an excessive period of time. Open the draincock immediately after the test to eliminate boil over of coolant.

Start the engine and accelerate rapidly three times (to approximately 3000 rpm) while observing the coolant. If internal engine combustion gases are leaking into the cooling system, bubbles will appear in the coolant. If bubbles do not appear, there is no internal combustion gas leakage.

COOLANT RESERVE/OVERFLOW SYSTEM

The system works along with the radiator pressure cap. This is done by using thermal expansion and contraction of the coolant to keep the coolant free of trapped air. It provides:

- A volume for coolant expansion and contraction.
- A convenient and safe method for checking/adjusting coolant level at atmospheric pressure. This is done without removing the radiator pressure cap.
- Some reserve coolant to cover minor leaks and evaporation or boiling losses.

The coolant reserve/overflow system consists of a radiator mounted pressurized cap, a plastic reserve/overflow tank (Figs. 21, 22 or 23), a tube connecting the radiator and tank, and an overflow tube on the side of the tank.

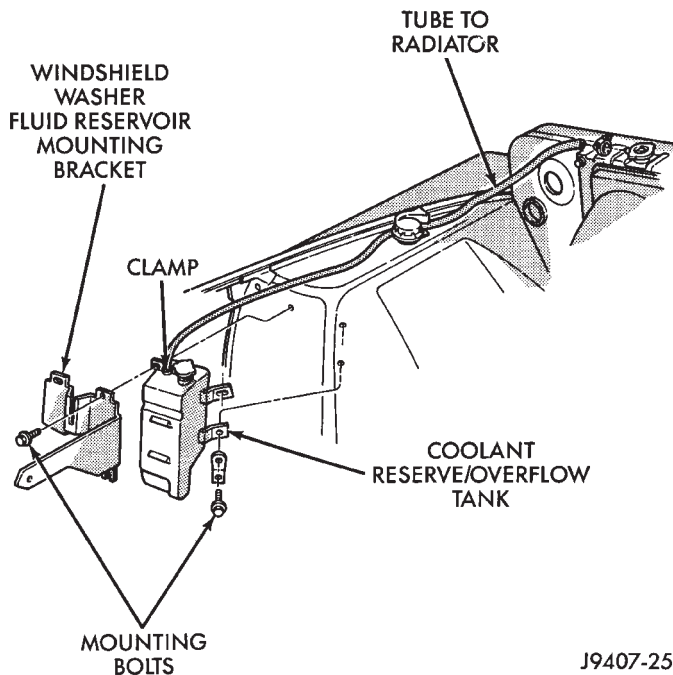

Fig. 21 Reserve/Overflow Tank—YJ Models

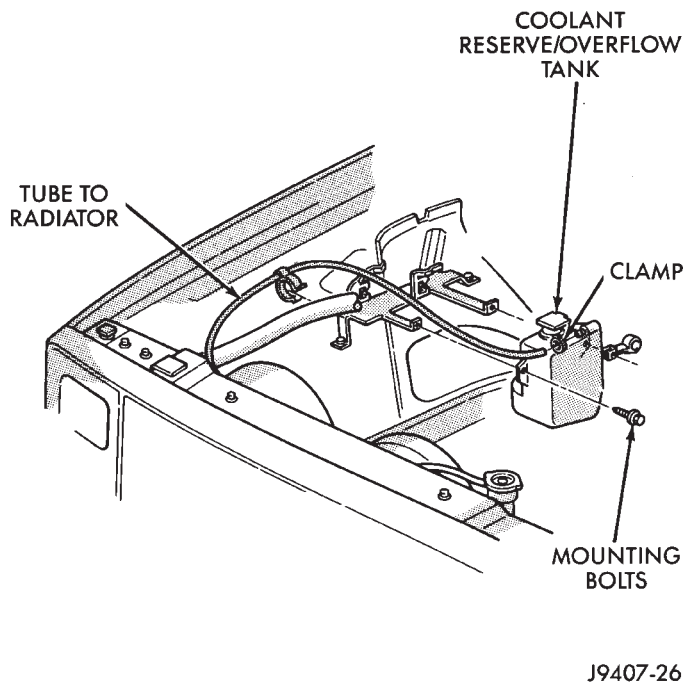

Fig. 22 Reserve/Overflow Tank—XJ Models—Except Right Hand Drive

TANK REMOVAL/INSTALLATION

(1) Remove the tube clamp at the tank and remove tube.

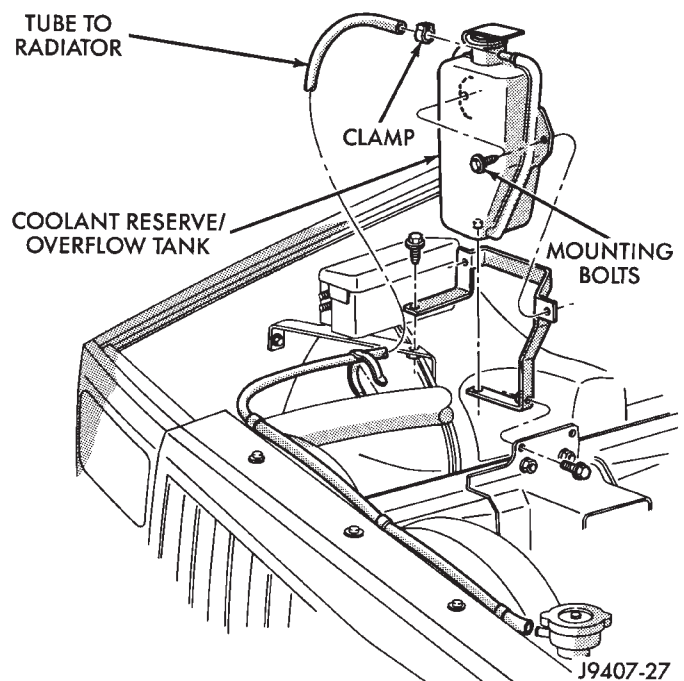

Fig. 23 Reserve/Overflow Tank—XJ Models—With Right Hand Drive

(2) On YJ models, remove the windshield washer reservoir and its mounting bracket.

(3) Remove the tank mounting bolts and remove tank.

(4) Reverse the preceding steps for installation.

RADIATOR PRESSURE CAP

All radiators are equipped with a pressure cap. This cap releases pressure at some point within a range of 83-110 kPa (12-16 psi). The pressure relief point (in pounds) is engraved on top of the cap (Fig. 24).

The cooling system will operate at pressures slightly above atmospheric pressure. This results in a higher coolant boiling point allowing increased radiator cooling capacity. The cap (Fig. 24) contains a spring-loaded pressure relief valve. This valve opens when system pressure reaches the release range of 83-110 kPa (12-16 psi).

A vent valve in the center of the cap allows a small coolant flow through the cap when coolant is below boiling temperature. The valve is completely closed when boiling point is reached. As coolant cools, it contracts and creates a vacuum in the cooling system. This causes the vacuum valve to open and coolant in reserve/overflow tank to be drawn through connecting hose into radiator. If the vacuum valve is stuck shut, radiator hoses will collapse on cool-down.

A rubber gasket seals the radiator filler neck. This is done to maintain vacuum during coolant cool-down and to prevent leakage when system is under pressure.

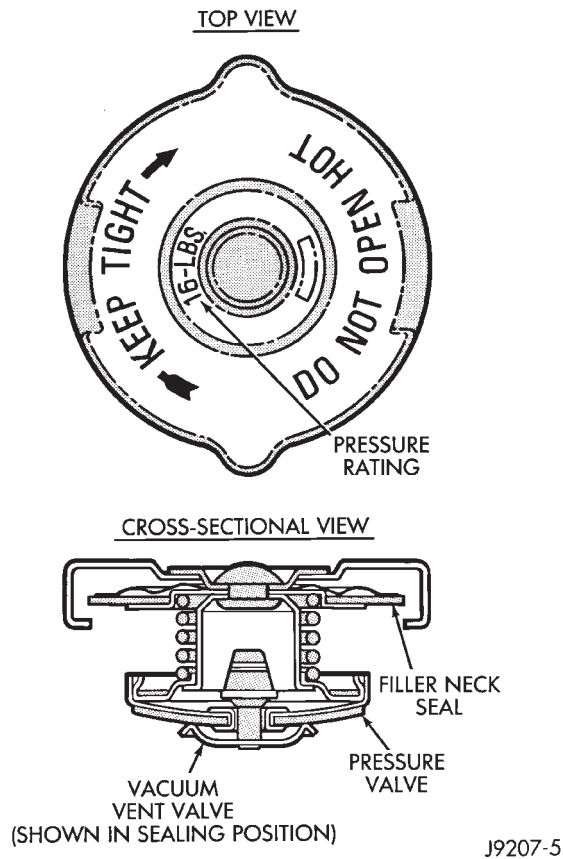

Fig. 24 Radiator Pressure Cap

RADIATOR CAP-TO-FILLER NECK SEAL—PRESSURE RELIEF CHECK

With radiator cap installed on filler neck, remove coolant reserve/ overflow tank hose from nipple on filler neck. Connect a hand operated vacuum pump to nipple. Operate pump until a reading of 47-to-61 kPa (14-to-18 in. Hg) appears on gauge. If the reading stays steady, or drops slightly and then remains steady, the pressure valve seal is good. Replace radiator cap if reading does not hold.

WARNING: THE WARNING WORDS -DO NOT OPEN HOT- ON THE RADIATOR PRESSURE CAP (FIG. 24) ARE A SAFETY PRECAUTION. WHEN HOT, PRESSURE BUILDS UP IN COOLING SYSTEM. TO PREVENT SCALDING OR INJURY, THE RADIATOR CAP SHOULD NOT BE REMOVED WHILE THE SYSTEM IS HOT AND/OR UNDER PRESSURE.

There is no need to remove the radiator cap **except** for the following purposes:

- (1) To check and adjust antifreeze freeze point.
- (2) To refill system with new antifreeze.
- (3) For conducting service procedures.
- (4) When checking for vacuum leaks.

WARNING: IF VEHICLE HAS BEEN RUN RECENTLY, WAIT AT LEAST 15 MINUTES BEFORE REMOVING RADIATOR CAP. WITH A RAG, SQUEEZE RADI-

ATOR UPPER HOSE TO CHECK IF SYSTEM IS UNDER PRESSURE. PLACE A RAG OVER THE CAP AND WITHOUT PUSHING DOWN, ROTATE CAP COUNTER-CLOCKWISE TO THE FIRST STOP. ALLOW FLUID TO ESCAPE THROUGH OVERFLOW HOSE INTO COOLANT RESERVE/OVERFLOW TANK. SQUEEZE RADIATOR UPPER HOSE TO DETERMINE WHEN PRESSURE HAS BEEN RELEASED. WHEN COOLANT AND STEAM STOP BEING PUSHED INTO TANK AND SYSTEM PRESSURE DROPS, REMOVE RADIATOR CAP COMPLETELY.

PRESSURE TESTING RADIATOR CAPS

Remove cap from radiator. Be sure that sealing surfaces are clean. Moisten rubber gasket with water and install the cap on pressure tester (tool 7700 or an equivalent) (Fig. 25).

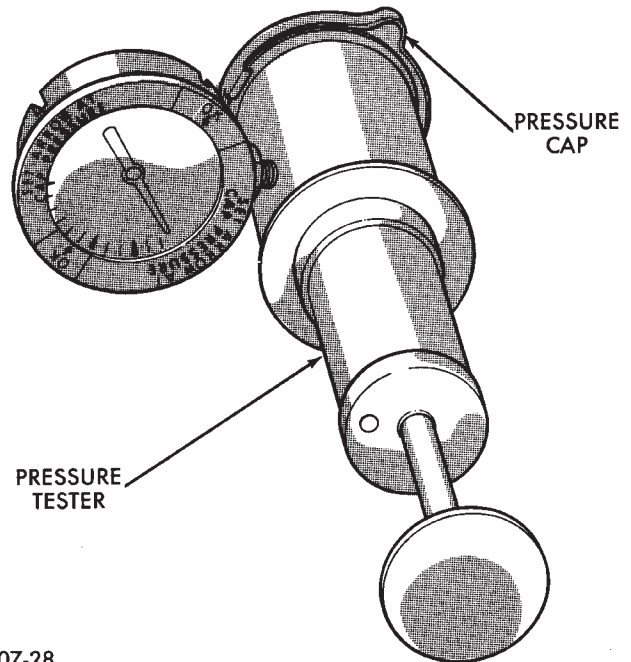

Fig. 25 Pressure Testing Radiator Pressure Cap

Operate the tester pump and observe the gauge pointer at its highest point. The cap release pressure should be 83-to-110 kPa (12-to-16 psi). The cap is satisfactory when the pressure holds steady. It is also good if it holds pressure within the 83-to-110 kPa (12-to-16 psi) range for 30 seconds or more. If the pointer drops quickly, replace the cap.

INSPECTION

Visually inspect the pressure valve gasket on the cap. Replace cap if the gasket is swollen, torn or worn. Inspect the area around radiator filler neck for white deposits that indicate a leaking cap.

RADIATORS

GENERAL INFORMATION

All radiators are down flow types except XJ models with 4.0L engines. Radiators in XJ models equipped with the 4.0L six-cylinder engine, are the cross flow type. Plastic tanks are used on all radiators.

CAUTION: Plastic tanks, while stronger than brass, are subject to damage by impact, such as wrenches.

If plastic tank has been damaged, plastic tank and/or O-rings are available for service repair. Tank replacement should be done by qualified personal with proper equipment.

RADIATOR COOLANT FLOW CHECK

The following procedure will determine if coolant is flowing through the cooling system.

If engine is cold, idle engine until normal operating temperature is reached. Then feel the upper radiator hose. If hose is hot, the thermostat is open and water is circulating through cooling system.

RADIATOR REMOVAL/INSTALLATION

WARNING: DO NOT REMOVE THE CYLINDER BLOCK DRAIN PLUGS, RADIATOR CAP, OR LOOSEN THE RADIATOR DRAINCOCK WITH THE SYSTEM HOT AND PRESSURIZED. SERIOUS BURNS FROM THE COOLANT CAN OCCUR.

DO NOT WASTE reusable coolant. If solution is clean, drain coolant into a clean container for reuse.

WARNING: CONSTANT TENSION HOSE CLAMPS ARE USED ON MOST COOLING SYSTEM HOSES. WHEN REMOVING OR INSTALLING, USE ONLY TOOLS DESIGNED FOR SERVICING THIS TYPE OF CLAMP, SUCH AS SPECIAL CLAMP TOOL (NUMBER 6094) (FIG. 26). SNAP-ON CLAMP TOOL (NUMBER HPC-20) MAY BE USED FOR LARGER CLAMPS. ALWAYS WEAR SAFETY GLASSES WHEN SERVICING CONSTANT TENSION CLAMPS.

CAUTION: A number or letter is stamped into the tongue of constant tension clamps. If replacement is necessary, use only an original equipment clamp with matching number or letter.

XJ MODELS WITH 2.5L ENGINE

REMOVAL

- (1) Disconnect negative battery cable at battery.
- (2) Observe the previous **WARNINGS**. Remove radiator cap.

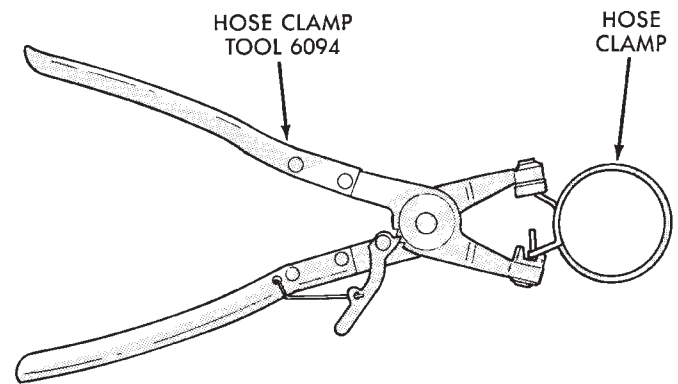

J9207-36

Fig. 26 Hose Clamp Tool—Typical

- (3) Position drain pan under draincock. Open radiator draincock. Drain radiator.
- (4) Remove radiator upper and lower hose clamps and hoses.
- (5) Remove alignment dowel E-clip from radiator lower mounting bracket (Fig. 27).

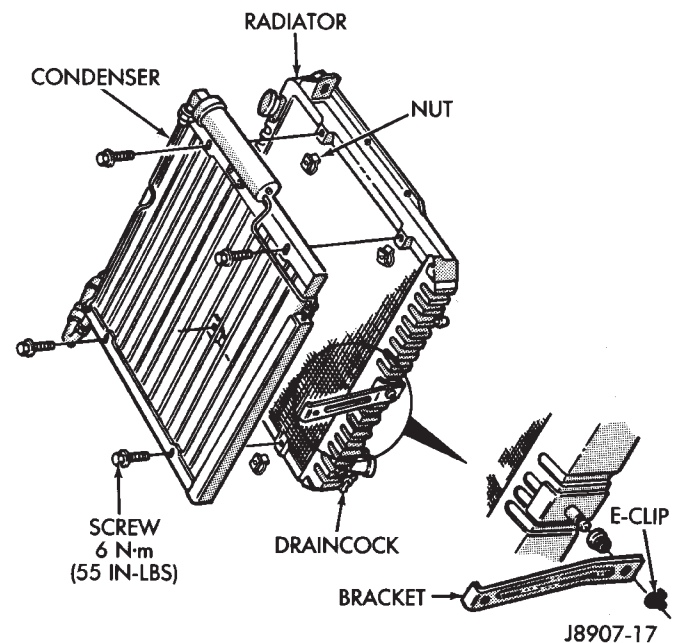

J8907-17

Fig. 27 Radiator Remove/Install—XJ Models—2.5L Engine

- (6) Disconnect coolant reserve/overflow tank hose from radiator.
- (7) Remove radiator fan shroud mounting bolts (Fig. 28). Push shroud back against front of engine.
- (8) If equipped, disconnect and plug automatic transmission fluid cooler lines.
- (9) Remove radiator top mounting bolts (Fig. 28).
- (10) Remove the radiator grille mounting screws. Remove grille (Fig. 29).
- (11) Remove the air conditioning condenser-to-radiator mounting bolt. Use an open end wrench to re-

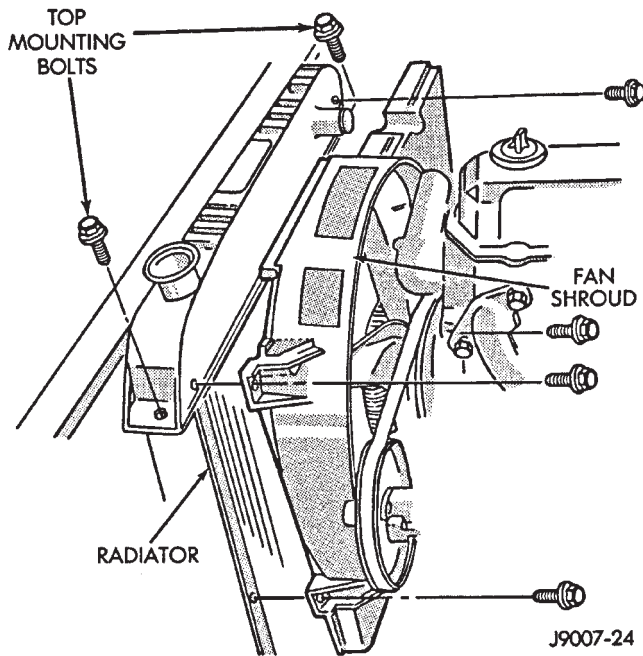

Fig. 28 Shroud Remove/Install—XJ Models With 2.5L Engine

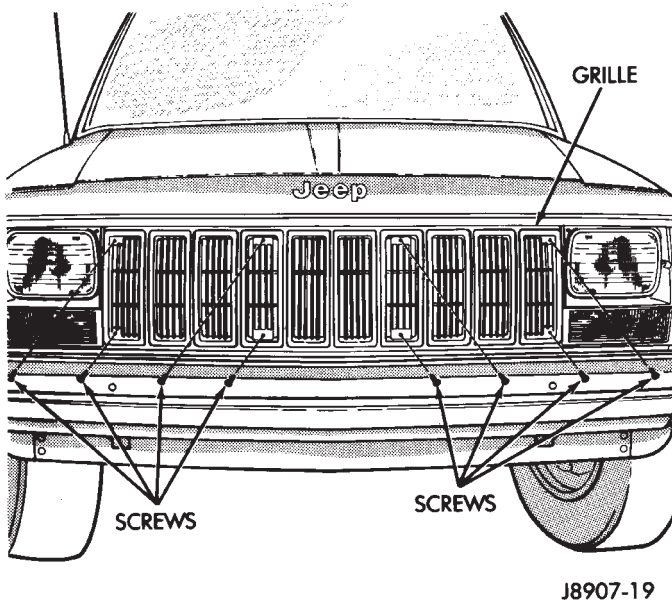

Fig. 29 Grille Remove/Install—Cherokee Models With 2.5L Engine

move bottom bolts (Fig. 30).

(12) Lift radiator straight up and out of vehicle. Take care not to damage radiator fins.

INSTALLATION

(1) Install radiator behind air conditioning condenser with bottom alignment dowel inserted into radiator lower mounting bracket.

(2) Install E-clip to alignment dowel.

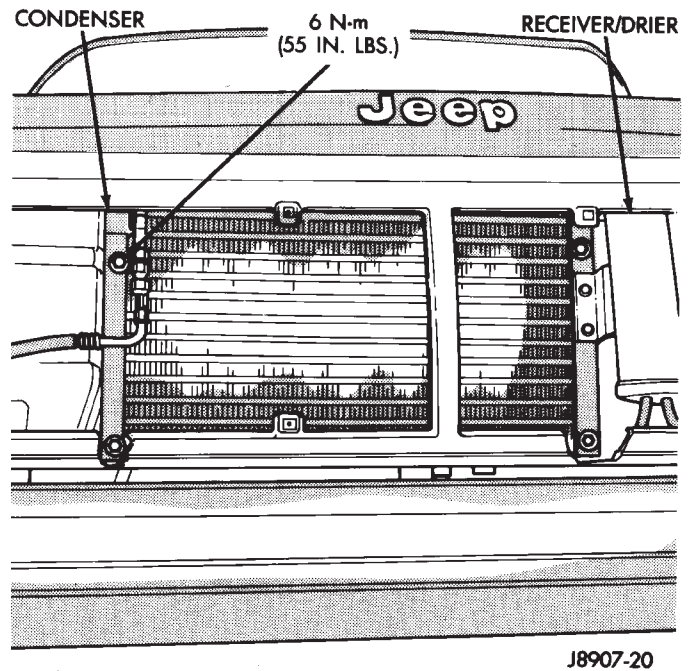

Fig. 30 Condenser Mounting Bolts—XJ Models With 2.5L Engine

(3) Tighten the four condenser-to-radiator mounting bolts to 6.2 N·m (55 in. lbs.) torque.

(4) Install radiator grille.

(5) Tighten radiator top mounting bolts to 6 N·m (55 in. lbs.) torque.

(6) If equipped, connect automatic transmission fluid cooler lines to radiator.

(7) Install the radiator fan shroud. Connect the coolant reserve/overflow tank hose.

(8) Connect radiator hoses and install hose clamps.

(9) Connect negative battery cable.

(10) Close the draincock.

(11) Fill cooling system with correct coolant.

(12) Install radiator cap.

(13) Check and adjust automatic transmission fluid level (if equipped).

XJ MODELS WITH 4.0L ENGINE

WARNING: DO NOT REMOVE THE CYLINDER BLOCK DRAIN PLUGS OR LOOSEN THE RADIATOR DRAINCOCK WITH THE SYSTEM HOT AND PRESSURIZED. SERIOUS BURNS FROM THE COOLANT CAN OCCUR.

DO NOT WASTE reusable coolant. If solution is clean, drain coolant into a clean container for reuse.

WARNING: CONSTANT TENSION HOSE CLAMPS ARE USED ON MOST COOLING SYSTEM HOSES. WHEN REMOVING OR INSTALLING, USE ONLY TOOLS DESIGNED FOR SERVICING THIS TYPE OF CLAMP, SUCH AS SPECIAL CLAMP TOOL (NUMBER 6094) (FIG. 26). SNAP-ON CLAMP TOOL (NUMBER HPC-20) MAY BE USED FOR LARGER CLAMPS. ALWAYS WEAR SAFETY GLASSES WHEN SERVICING CONSTANT TENSION CLAMPS.

CAUTION: A number or letter is stamped into the tongue of constant tension clamps. If replacement is necessary, use only an original equipment clamp with matching number or letter.

REMOVAL

- (1) Disconnect negative battery cable at battery.
- (2) Observe the previous **WARNINGS**.
- (3) Remove pressure cap.
- (4) For access to radiator draincock, remove radiator grille (Fig. 29).
- (5) Attach one end of a 24 inch long X 1/4 inch ID hose to the radiator draincock. Put the other end into a clean container. Open draincock and drain radiator.
- (6) If equipped, disconnect electric cooling fan electrical connector (Fig. 31).

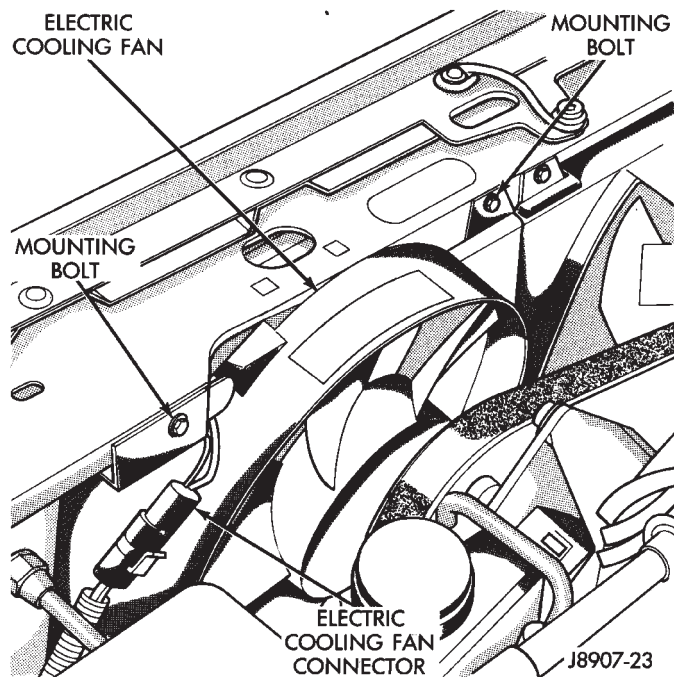

Fig. 31 Auxiliary Fan—Remove/Install

- (7) Remove electric fan mounting bolts. Lift fan straight up and out of engine compartment.
- (8) Remove the mechanical (non-electrical) fan shroud mounting bolts. Lift shroud up until align-

ment tabs at the bottom are clear of slots in bracket at bottom of radiator (Fig. 32). Place shroud over mechanical fan.

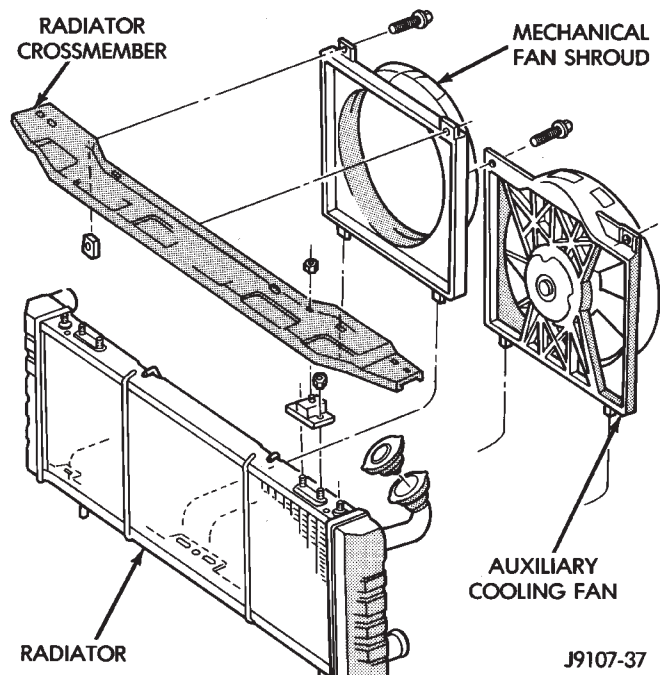

Fig. 32 Auxiliary Fan and Mechanical Fan Shroud—Remove/Install—Typical

- (9) If equipped, disconnect and plug automatic transmission fluid cooler lines. If equipped with remote cooler, remove line to cooler from bracket at bottom of radiator.
- (10) Disconnect radiator upper and lower hoses.
- (11) Mark the position of the hood latch striker on the radiator crossmember and remove hood latch striker.
- (12) Remove radiator upper crossmember bracket.
- (13) Remove radiator upper crossmember.
- (14) If equipped with air conditioning, separate radiator from condenser by removing condenser-to-radiator mounting brackets (Fig. 33).
- (15) Lift radiator straight up and out of engine compartment taking care not to damage fins.

INSTALLATION

The radiator has two alignment dowels. They are located on the bottom tank and fit into rubber grommets in the radiator lower crossmember.

- (1) Lower radiator into engine compartment. Position alignment dowels into grommets in radiator lower crossmember (Fig. 34).
- (2) If equipped with air conditioning, attach condenser to radiator with mounting brackets (Fig. 33).
- (3) Install radiator upper crossmember.
- (4) Install radiator upper crossmember bracket.
- (5) Install hood latch striker.
- (6) Connect radiator upper and lower hoses.

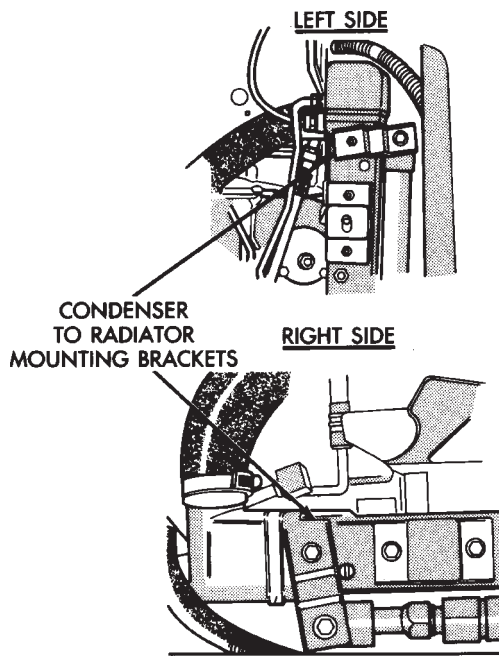

J-8907-26

Fig. 33 Condenser-to-Radiator Mounting Brackets—XJ with 4.0L Engine

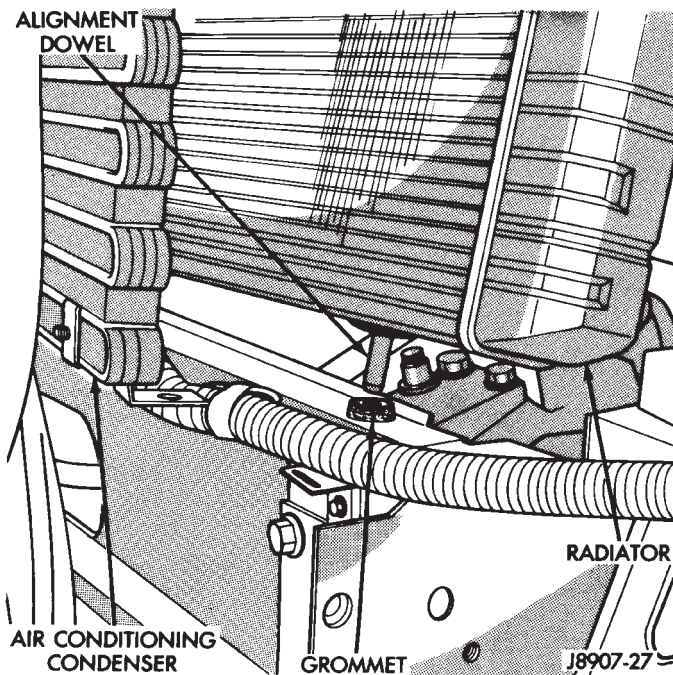

Fig. 34 Radiator Installation—XJ Models with 4.0L Engine

(7) If equipped, connect automatic transmission fluid cooler lines. If equipped with remote cooler, attach cooler line to bracket at bottom of radiator.

(8) Install electric cooling fan (if equipped). Insert alignment tabs at bottom of fan shroud into slots in bracket at bottom of radiator. Tighten mounting bolts to 4 N·m (36 in. lbs.) torque.

(9) Connect electric cooling fan electrical connector.

(10) Install mechanical cooling fan shroud. Insert alignment tabs at bottom of shroud into slots in bracket at bottom of radiator. Tighten mounting bolts to 4 N·m (36 in. lbs.) torque (Fig. 32).

(11) Close radiator draincock.

(12) Install grille.

(13) Connect negative battery cable.

(14) Fill cooling system with correct coolant. Refer to the Coolant section of this group.

(15) Install pressure cap.

(16) Check and adjust automatic transmission fluid level (if equipped).

YJ MODELS

WARNING: DO NOT REMOVE THE CYLINDER BLOCK DRAIN PLUGS OR LOOSEN THE RADIATOR DRAINCOCK WITH THE SYSTEM HOT AND PRESURIZED. SERIOUS BURNS FROM THE COOLANT CAN OCCUR.

DO NOT WASTE reusable coolant. If solution is clean, drain coolant into a clean container for reuse.

WARNING: CONSTANT TENSION HOSE CLAMPS ARE USED ON MOST COOLING SYSTEM HOSES. WHEN REMOVING OR INSTALLING, USE ONLY TOOLS DESIGNED FOR SERVICING THIS TYPE OF CLAMP, SUCH AS SPECIAL CLAMP TOOL (NUMBER 6094) (FIG. 26). SNAP-ON CLAMP TOOL (NUMBER HPC-20) MAY BE USED FOR LARGER CLAMPS. ALWAYS WEAR SAFETY GLASSES WHEN SERVICING CONSTANT TENSION CLAMPS.

CAUTION: A number or letter is stamped into the tongue of constant tension clamps. If replacement is necessary, use only an original equipment clamp with matching number or letter.

REMOVAL

(1) Disconnect negative battery cable at battery.

(2) Observe the previous **WARNINGS**. Remove the radiator cap.

(3) Position drain pan under draincock. Open radiator draincock and drain radiator.

(4) Remove radiator upper and lower hose clamps and hoses.

(5) Disconnect coolant reserve/overflow tank hose from radiator.

(6) Remove fan shroud bolts and push shroud back onto fan (Fig. 35).

(7) If equipped, disconnect and plug automatic transmission fluid cooler lines.

(8) Remove radiator attaching bolts.

(9) Lift radiator straight up and out of vehicle taking care not to damage radiator fins.

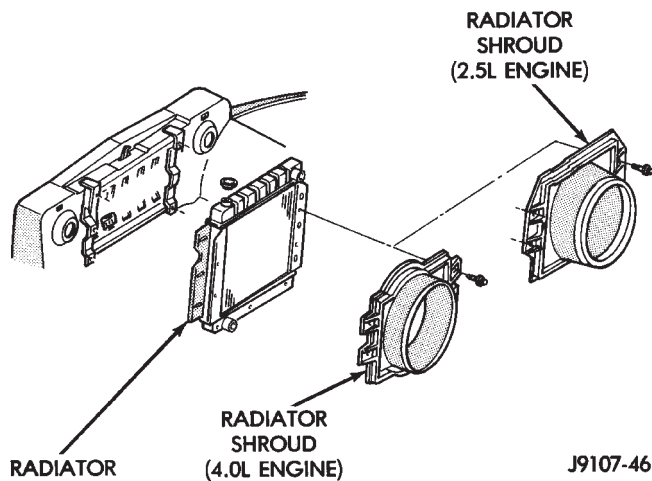

Fig. 35 Radiator—Remove/Install—YJ Models

INSTALLATION

- (1) Install the radiator. Tighten the mounting bolts to 8 N·m (6 ft. lbs.) torque (Fig. 35).
- (2) Close radiator draincock.
- (3) Install fan shroud. Tighten mounting bolts to 16 N·m (11 ft. lbs.) torque.
- (4) If equipped, remove plugs and connect automatic transmission fluid cooler lines.
- (5) Connect radiator hoses and install hose clamps.
- (6) Connect negative battery cable.
- (7) Fill cooling system with correct coolant. Refer to the Coolant section of this group.
- (8) Connect reserve/overflow tank hose.
- (9) Install radiator cap.
- (10) Check and adjust automatic transmission fluid level (if equipped).

COOLING SYSTEM HOSES

Rubber hoses route coolant to and from the radiator, intake manifold and heater core. All XJ models equipped with air conditioning have a coolant control valve. This is located in-line with the heater core inlet and outlet hoses. It controls coolant flow to the heater core when the air conditioning system is in operation.

Radiator lower hoses are spring-reinforced to prevent collapse from water pump suction at moderate and high engine speeds.

WARNING: CONSTANT TENSION HOSE CLAMPS ARE USED ON MOST COOLING SYSTEM HOSES. WHEN REMOVING OR INSTALLING, USE ONLY TOOLS DESIGNED FOR SERVICING THIS TYPE OF CLAMP, SUCH AS SPECIAL CLAMP TOOL (NUMBER 6094) (FIG. 36). SNAP-ON CLAMP TOOL (NUMBER HPC-20) MAY BE USED FOR LARGER CLAMPS. ALWAYS WEAR SAFETY GLASSES WHEN SERVICING CONSTANT TENSION CLAMPS.

CAUTION: A number or letter is stamped into the tongue of constant tension clamps. If replacement is necessary, use only an original equipment clamp with matching number or letter.

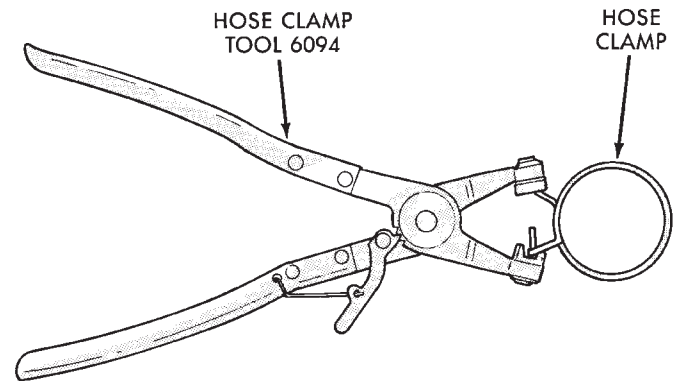

J9207-36

Fig. 36 Hose Clamp Tool—Typical

Inspect the hoses at regular intervals. Replace hoses that are cracked, feel brittle when squeezed, or swell excessively when the system is pressurized.

For all vehicles: In areas where specific routing clamps are not provided, be sure that hoses are positioned with sufficient clearance. Check clearance from exhaust manifolds and pipe, fan blades, drive belts and sway bars. Improperly positioned hoses can be damaged, resulting in coolant loss and engine overheating.

Ordinary worm gear type hose clamps (when equipped) can be removed with a straight screwdriver or a hex socket. **To prevent damage to hoses or clamps, the hose clamps should be tightened to 4 N·m (34 in. lbs.) torque. Do not over tighten hose clamps.**

When performing a hose inspection, inspect the radiator lower hose for proper position and condition of the internal spring.

COOLING SYSTEM FANS

All models are equipped with a mechanical temperature controlled fan. The viscous fan drive is a torque-and-temperature-sensitive clutch unit. It automatically increases or decreases fan speed to provide proper engine cooling. XJ models equipped with a 4.0L engine may also have an auxiliary electrical fan. This is with models that have air conditioning and/or heavy duty cooling.

VISCOUS FAN DRIVE OPERATION

The viscous fan drive (Fig. 37) is a silicone-fluid-filled coupling. On some engines it connects the fan assembly to the fan/water pump pulley. The coupling allows the fan to be driven in a normal manner. This is done at low engine speeds while limiting the top

speed of the fan to a predetermined maximum level at higher engine speeds. A bimetallic spring coil is located on the front face. This spring coil reacts to the temperature of the radiator discharge air. It engages the viscous fan drive for higher fan speed if the air temperature from the radiator rises above a certain point. Until additional engine cooling is necessary, the fan will remain at a reduced rpm regardless of engine speed.

Only when sufficient heat is present, will the viscous fan drive engage. This is when the air flowing through the radiator core causes a reaction from the bimetallic coil. It then increases fan speed to provide the necessary additional engine cooling.

Once the engine has cooled, the radiator discharge temperature will drop. The bimetallic coil again reacts and the fan speed is reduced to the previous disengaged speed.

CAUTION: Engines equipped with serpentine drive belts have reverse rotating fans and viscous fan drives. They are marked with the word **REVERSE** to designate their usage. Installation of the wrong fan or viscous fan drive can result in engine overheating.

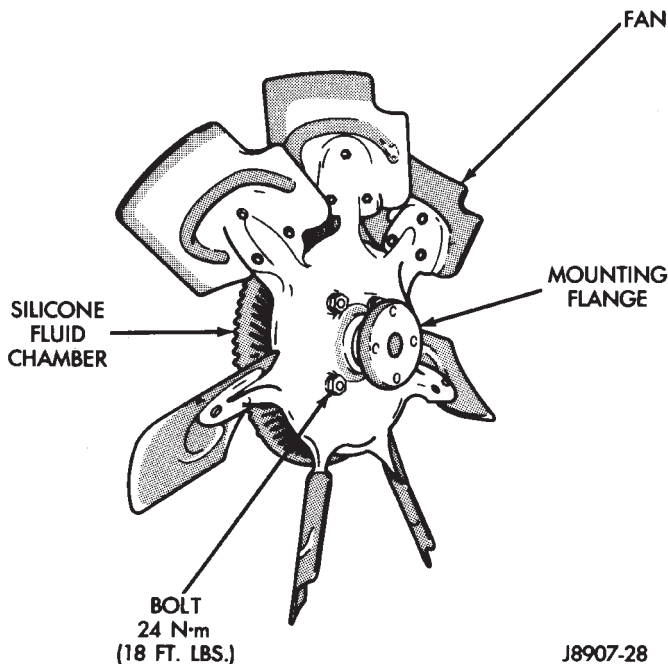

Fig. 37 Viscous Fan Drive—Typical

VISCOUS FAN DRIVE TEST

The cooling system must be in good condition. This is checked prior to performing the following test. It also will ensure against excessively high coolant temperature.

CAUTION: Be sure that there is adequate fan blade clearance before drilling.

(1) Drill a 3.18-mm (1/8-in) diameter hole in the top center of the fan shroud.

(2) Obtain a dial thermometer with an 8 inch stem (or equivalent). It should have a range of -18° -to- 105° C (0° -to- 220° F). Insert thermometer through the hole in the shroud. Be sure that there is adequate clearance from the fan blades.

(3) Connect a tachometer and an engine ignition timing light (timing light is to be used as a strobe light).

(4) Block the air flow through the radiator. Secure a sheet of plastic in front of the radiator (or air conditioner condenser). Use tape at the top to secure the plastic and be sure that the air flow is blocked.

(5) Be sure that the air conditioner (if equipped) is turned off.

WARNING: USE EXTREME CAUTION WHEN THE ENGINE IS OPERATING. DO NOT STAND IN A DIRECT LINE WITH THE FAN. DO NOT PUT YOUR HANDS NEAR THE PULLEYS, BELTS OR FAN. DO NOT WEAR LOOSE CLOTHING.

(6) Start the engine and operate at 2400 rpm with the timing light (strobe light) aimed at the fan blades. Within ten minutes the air temperature (indicated on the dial thermometer) should be 88° C (190° F). Satisfactory operation of the fan drive requires that it engage before or at 88° C (190° F). Engagement is distinguishable by a definite increase in flow noise. The timing light also will indicate an increase in the speed of the fan.

(7) When the air temperature reaches 88° C (190° F), remove the plastic sheet. Satisfactory operation of the viscous fan requires the air temperature to drop 20° F (11° C) or more. A definite decrease of audible-fan-air-flow-noise should be noticed. Replace defective fan assemblies.

VISCOUS FAN DRIVE REPLACEMENT

REMOVAL

Some engines have the mechanical fan/viscous fan drive assembly mounted directly to the water pump hub (Fig. 38). It may also be mounted to a hub/bearing attached to an aluminum bracket on the right front side of engine (Fig. 39).

(1) Loosen but do not remove at this time, the four fan hub mounting nuts (Figs. 38 or 39).

(2) Remove accessory serpentine drive belt. Refer to Belt Service in the Engine Accessory Drive Belt section of this group.

(3) Some models with certain engines may require the removal of the fan shroud to remove the viscous fan drive. The fan shroud and fan blade/viscous fan drive should be removed from the vehicle as one assembly.

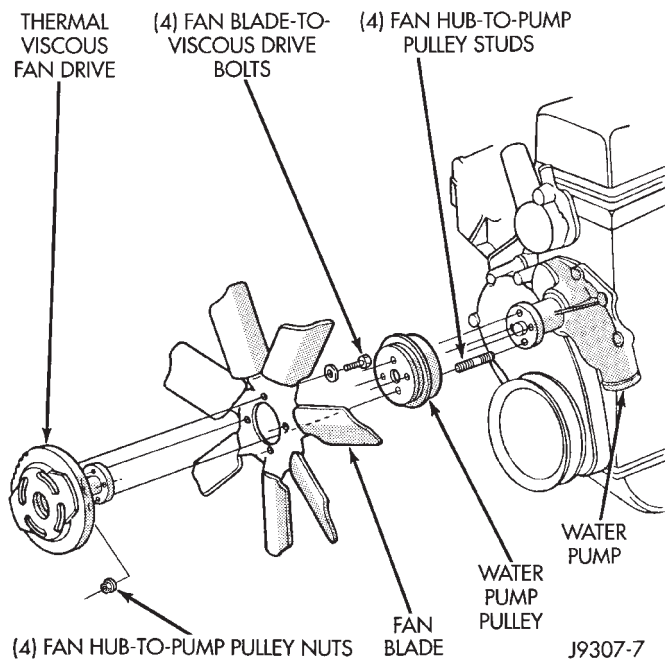

Fig. 38 Water Pump Mounted Cooling Fan

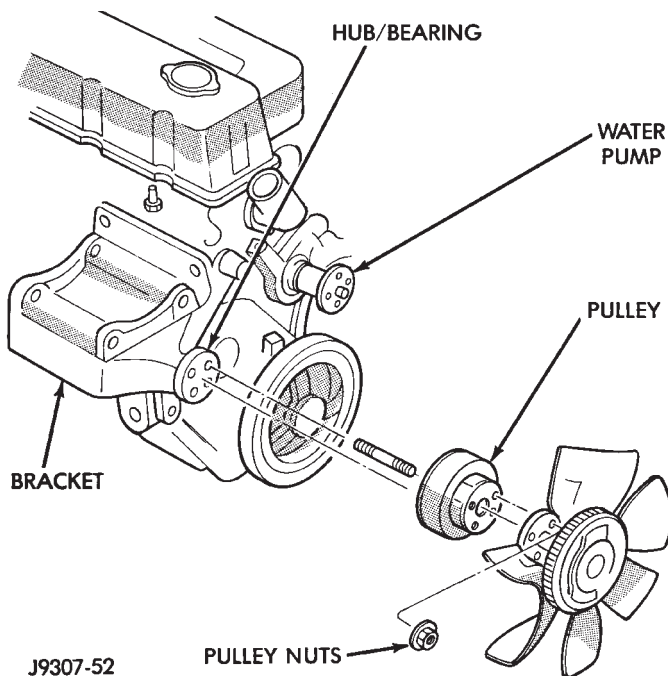

Fig. 39 Bracket Mounted Cooling Fan

(4) Remove four fan hub mounting nuts (Figs. 38 or 39) and remove fan/viscous fan drive assembly from vehicle.

After removing fan blade/viscous fan drive assembly, **do not** place thermal viscous fan drive in horizontal position. If stored horizontally, silicone fluid in viscous fan drive could drain into its bearing assembly and contaminate lubricant.

INSTALLATION

(1) Assemble fan blade to viscous fan drive. Tighten mounting bolts to 27 N·m (20 ft. lbs.) torque.

(2) Position mounting flange of fan blade/viscous fan drive assembly onto hub. Install four nuts and tighten to 24 N·m (18 ft. lbs.) torque. Tighten the first two nuts 180 degrees apart. Then tighten last two nuts.

CAUTION: When installing a serpentine accessory drive belt, the belt **MUST** be routed correctly. If not, the engine may overheat due to the water pump rotating in the wrong direction. Refer to appropriate Engine Accessory Drive Belt Schematic in this group for correct belt routing.

(3) Install accessory drive belts. Tension belts to specifications. Refer to the Specifications section at the end of this group.

FAN BLADE INSPECTION

The fan blades cannot be repaired. If the fan is damaged, it must be replaced. Inspect the fan blades as follows:

Lay fan blade assembly on a flat surface with leading edge facing down. With tip of blade touching flat surface, replace fan if clearance between opposite blade and surface is greater than 2.0 mm (.090 inch). Rocking motion of opposite blades should not exceed 2.0 mm (.090 inch). Test all blades in this manner.

WARNING: DO NOT ATTEMPT TO BEND OR STRAIGHTEN FAN BLADES IF NOT WITHIN SPECIFICATIONS.

Inspect fan assembly for cracks, bends, loose rivets or broken welds. Replace fan if any damage is found.

CAUTION: If the fan blade assembly is replaced because of mechanical damage, the water pump and viscous fan drive should also be inspected. These components could have been damaged due to excessive vibration.

AUXILIARY ELECTRIC COOLING FAN—XJ MODELS WITH 4.0L ENGINE

OPERATION

XJ models equipped with a 4.0L engine may also have an auxiliary electrical fan. This is with models that have air conditioning and/or heavy duty cooling. The fan is controlled by the cooling fan relay, which is located in the Power Distribution Center (PDC). For location of relay within the PDC (Fig. 40), refer to label on PDC cover.

When coolant temperature is above 88°C (190°F), the powertrain control module (PCM) grounds the relay. Battery voltage is then applied to the fan

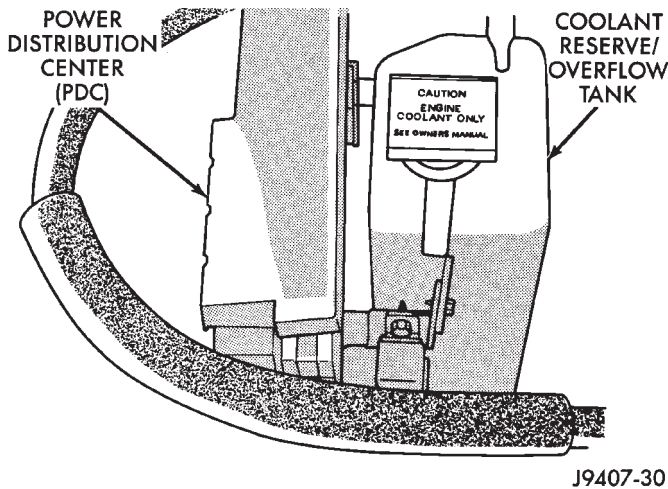

Fig. 40 PDC—XJ Models

through the relay. When coolant temperature is below 88°C (190°F), the PCM opens the ground path to the relay. This will prevent the cooling fan from being energized.

Whenever the air conditioning is used, the PCM engages the auxiliary cooling fan. It provides a ground path to the cooling fan relay.

DIAGNOSIS

The powertrain control module (PCM) will enter a diagnostic trouble code (DTC) number 35 in memory if it detects a problem in the auxiliary cooling fan relay or circuit. This will be read as a flashing signal at the instrument panel mounted Malfunction Indicator Lamp (formerly referred to as the Check Engine Lamp). Refer to On-Board Diagnostics in Group 14, Fuel Systems for information on accessing a DTC.

The DTC can also be accessed through the DRB scan tool. Refer to the appropriate Powertrain Diagnostic Procedures manual for diagnostic information and operation of the DRB scan tool.

REMOVAL

The auxiliary fan is attached to the radiator upper crossmember behind the radiator.

- (1) Remove the fan retaining bolts from radiator upper crossmember (Fig. 41).
- (2) Disconnect the electric fan connector.
- (3) Lift fan straight up and out of vehicle.

INSTALLATION

- (1) Align lower retaining tabs of fan shroud with slots in bracket at bottom of radiator. Push fan down into position.
- (2) Tighten the mounting bolts to 4 N·m (31 in. lbs.) torque.
- (3) Connect auxiliary cooling fan electrical connector.

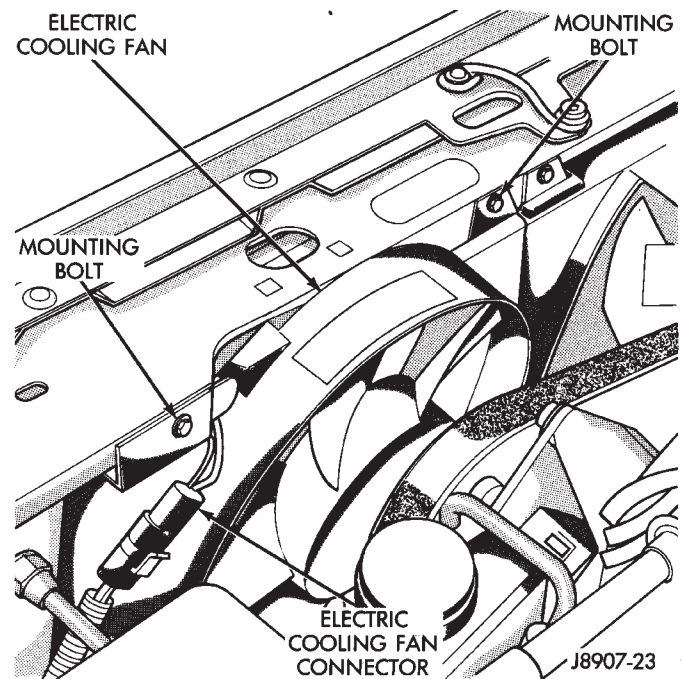

Fig. 41 Auxiliary Fan—Remove/Install

TRANSMISSION OIL COOLERS

WATER-TO-OIL COOLER

All models equipped with an automatic transmission are equipped with a transmission oil cooler mounted internally within the radiator tank. This internal cooler is supplied as standard equipment on all models equipped with an automatic transmission.

Transmission oil is cooled when it passes through this separate cooler. In case of a leak in the internal radiator mounted transmission oil cooler, engine coolant may become mixed with transmission fluid or transmission fluid may enter engine cooling system. Both cooling system and transmission should be drained and inspected if the internal radiator mounted transmission cooler is leaking.

Also refer to the section on Transmission Air-to-Oil Coolers. This auxiliary air-to-oil cooler is an option on most engine packages.

REPLACING WATER-TO-OIL COOLER IN RADIATOR SIDE TANK

The internal transmission oil cooler located within the radiator is not serviceable. If it requires service, the radiator must be replaced.

Once the repaired or replacement radiator has been installed, fill the cooling system and inspect for leaks. Refer to the Refilling Cooling System and Testing Cooling System For Leaks sections in this group. If the transmission operates properly after repairing the leak, drain the transmission and remove the transmission oil pan. Inspect for sludge and/or rust. Inspect for a dirty or plugged inlet filter. If none of these conditions are found, the transmission

and torque convertor may not require reconditioning. Refer to Group 21 for automatic transmission servicing.

AIR-TO-OIL COOLER

An auxiliary air-to-oil transmission oil cooler is available with most engine packages.

On XJ and YJ models, the cooler is located in front of the radiator or A/C condenser (if equipped) and behind the grill (Figs. 42 or 43). It is mounted to the front frame crossmember.

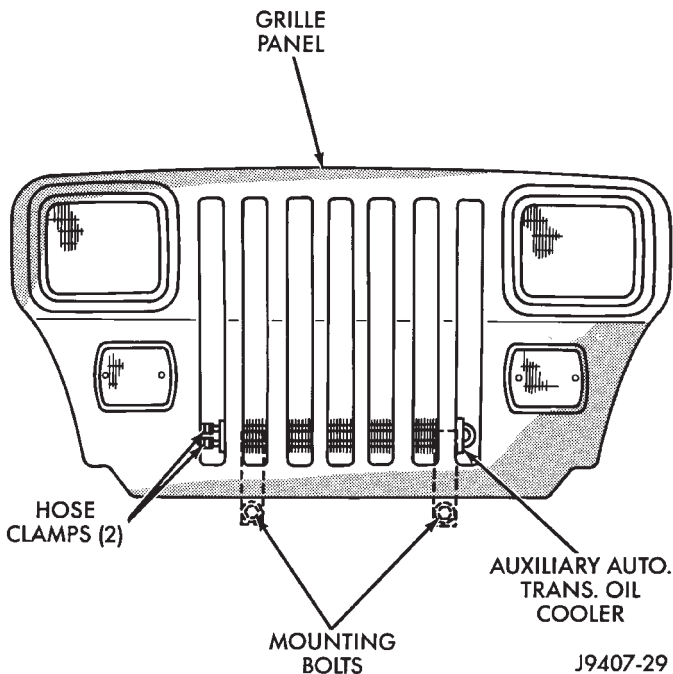

Fig. 42 Auxiliary Air-To-Oil Cooler—YJ Models

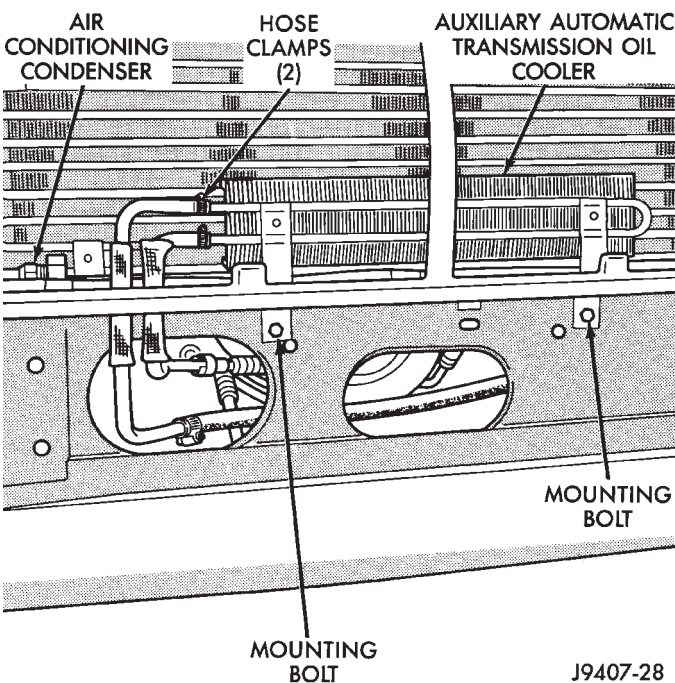

Fig. 43 Auxiliary Air-To-Oil Cooler—XJ Models

The auxiliary oil coolers on all models operate in conjunction with the internal radiator mounted main oil cooler. The transmission oil is routed through the main cooler first, then the auxiliary cooler, before returning to the transmission.

REMOVAL/INSTALLATION—XJ MODELS

- (1) Remove the grill. Refer to Group 23, Body.
- (2) Place a drain pan below the transmission oil cooler.
- (3) Remove the two hose clamps at oil cooler inlet and outlet tubes (Fig. 42).
- (4) Remove the two oil cooler mounting bolts (Fig. 42).
- (5) Remove the oil cooler from vehicle.
- (6) Reverse the preceding operation for installation. Tighten the two clamps 2 N·m (15 in. lbs.) torque.

REMOVAL/INSTALLATION—YJ MODELS

- (1) Remove fan shroud and radiator. Refer to Group 7, Cooling for procedures.
- (2) Remove the air conditioning filter/drier mounting bolts.

CAUTION: Before proceeding with the next step, be sure to wear safety glasses. The A/C system is under pressure even with the system off.

- (3) Remove the A/C condenser mounting bolts (Fig. 44).

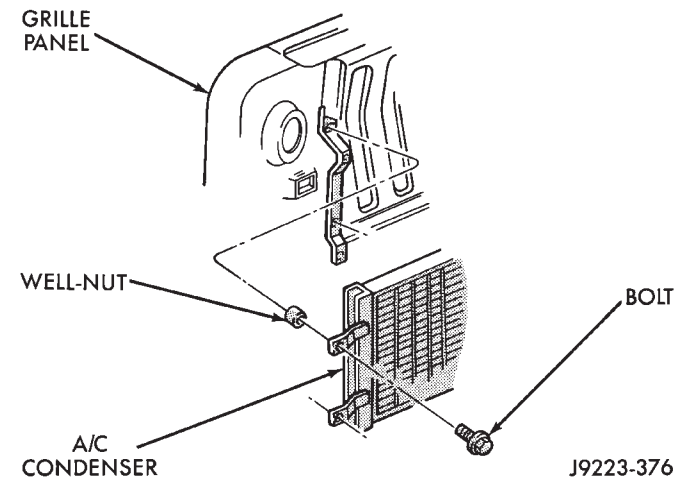

Fig. 44 Condenser Mounting Bolts—YJ Models

- (4) Carefully tilt the A/C condenser rearward for access to the auxiliary transmission oil cooler.
- (5) Place a drain pan below the oil cooler.
- (6) Remove the two hose clamps at oil cooler inlet and outlet tubes (Fig. 43).
- (7) Remove the two oil cooler mounting bolts (Fig. 43).
- (8) Remove the oil cooler from vehicle.
- (9) Reverse the preceding operation for installation. Tighten the two clamps 2 N·m (15 in. lbs.) torque.

ENGINE ACCESSORY DRIVE BELTS

INDEX

	page		page
Automatic Belt Tensioner—XJ Models	36	Belt Tension Specifications	34
Belt Diagnosis	31	Belt Tension—Except Right Hand Drive (RHD)	33
Belt Schematics	34	Belt Tension—Right Hand Drive (RHD)	34
Belt Service—Except Right Hand Drive	34	General Information	31
Belt Service—With Right Hand Drive	35		

GENERAL INFORMATION

CAUTION: When installing a serpentine accessory drive belt, the belt **MUST** be routed correctly. If not, the engine may overheat due to water pump rotating in wrong direction. Refer to the appropriate engine Belt Schematic in this group for the correct belt routing. Or, refer to the Belt Routing Label located in the engine compartment.

BELT DIAGNOSIS

When diagnosing serpentine accessory drive belts, small cracks that run across the ribbed surface of the belt from rib to rib (Fig. 1), are considered normal. These are not a reason to replace the belt. However, cracks running along a rib (not across) are **not** normal. Any belt with cracks running along a rib must be replaced (Fig. 1). Also replace the belt if it has excessive wear, frayed cords or severe glazing.

Refer to the Serpentine Accessory Drive Belt Diagnosis charts for further belt diagnosis.

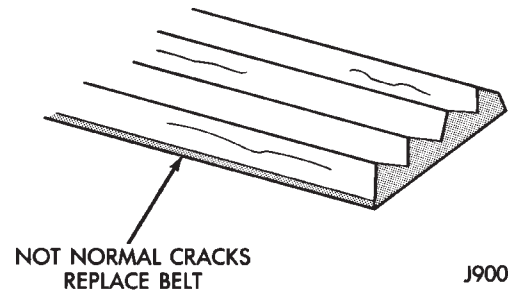
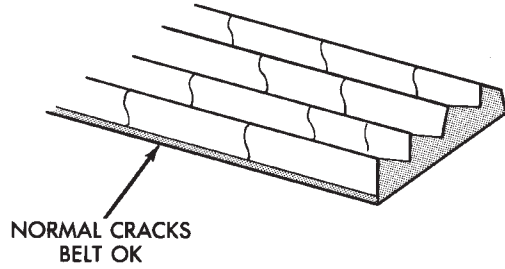

J9007-44

Fig. 1 Serpentine Belt Wear Patterns

SERPENTINE DRIVE BELT DIAGNOSIS

Condition	Possible Cause	Correction
RIB CHUNKING (ONE OR MORE RIBS HAS SEPARATED FROM BELT BODY)	(1) Foreign objects imbedded in pulley grooves. (2) Installation damage.	(1) Remove foreign objects from pulley grooves. Replace belt. (2) Replace belt.
RIB OR BELT WEAR	(1) Pulley(s) misaligned. (2) Abrasive environment. (3) Rusted pulley(s). (4) Sharp or jagged pulley groove tips. (5) Rubber deteriorated.	(1) Align pulley(s). (2) Clean pulley(s). Replace belt if necessary. (3) Clean rust from pulley(s). (4) Replace pulley. (5) Replace belt.
LONGITUDINAL BELT CRACKING (CRACKS BETWEEN TWO RIBS)	(1) Belt has mistracked from pulley groove. (2) Pulley groove tip has worn away rubber to tensile member.	(1) Replace belt. (2) Replace belt.
BELT SLIPS	(1) Belt slipping because of insufficient tension. (2) Belt or pulley subjected to substance (belt dressing, oil, ethylene glycol) that has reduced friction. (3) Driven component bearing failure. (4) Belt glazed and hardened from heat and excessive slippage.	(1) Adjust tension. (2) Replace belt and clean pulleys. (3) Replace faulty component bearing. (4) Replace belt.
"GROOVE JUMPING" (BELT DOES NOT MAINTAIN CORRECT POSITION ON PULLEY)	(1) Belt tension either too high or too low. (2) Pulley(s) not within design tolerance. (3) Foreign object(s) in grooves. (4) Pulley misalignment. (5) Belt cordline is broken.	(1) Adjust belt tension. (2) Replace pulley(s). (3) Remove foreign objects from grooves. (4) Align pulley(s). (5) Replace belt.
BELT BROKEN (NOTE: IDENTIFY AND CORRECT PROBLEM BEFORE NEW BELT IS INSTALLED)	(1) Excessive tension. (2) Tensile members damaged during belt installation. (3) Severe misalignment. (4) Bracket, pulley, or bearing failure.	(1) Replace belt and adjust tension to specification. (2) Replace belt. (3) Align pulley(s). (4) Replace defective component and belt.
NOISE (OBJECTIONAL SQUEAL, SQUEAK, OR RUMBLE IS HEARD OR FELT WHILE DRIVE BELT IS IN OPERATION)	(1) Belt slippage. (2) Bearing noise. (3) Belt misalignment. (4) Belt-to-pulley mismatch.	(1) Adjust belt. (2) Locate and repair. (3) Align belt/pulley(s). (4) Install correct belt.

SERPENTINE DRIVE BELT DIAGNOSIS (CONT.)

Condition	Possible Cause	Correction
NOISE (OBJECTIONAL SQUEAL, SQUEAK, OR RUMBLE IS HEARD OR FELT WHILE DRIVE BELT IS IN OPERATION) (Continued)	(5) Driven component induced vibration. (6) System resonant frequency induced vibration.	(5) Locate defective driven component and repair. (6) Vary belt tension within specifications. Replace belt.
TENSION SHEETING FABRIC FAILURE (WOVEN FABRIC ON OUTSIDE CIRCUMFERENCE OF BELT HAS CRACKED OR SEPARATED FROM BODY OF BELT)	(1) Tension sheeting contacting stationary object. (2) Excessive heat causing woven fabric to age. (3) Tension sheeting splice has fractured.	(1) Correct rubbing condition. (2) Replace belt. (3) Replace belt.
CORD EDGE FAILURE (TENSILE MEMBER EXPOSED AT EDGES OF BELT OR SEPARATED FROM BELT BODY)	(1) Excessive tension. (2) Belt contacting stationary object. (3) Pulley(s) out of tolerance. (4) Insufficient adhesion between tensile member and rubber matrix.	(1) Adjust belt tension. (2) Correct as necessary. (3) Replace pulley. (4) Replace belt and adjust tension to specifications.

E8907-144

BELT TENSION—EXCEPT RIGHT HAND DRIVE (RHD)

Correct drive belt tension is required to ensure optimum performance of the belt driven engine accessories. There are different types of adjustment gauges for checking either a serpentine or a V-type belt. Refer to the instructions supplied with the

gauge. Use the correct gauge when checking belt tension. Place gauge in the middle of the section of belt being tested (between two pulleys) to check tension (Figs. 2, 3, 4 or 5). Do not allow the gauge (or gauge adapter) to contact anything but the belt.

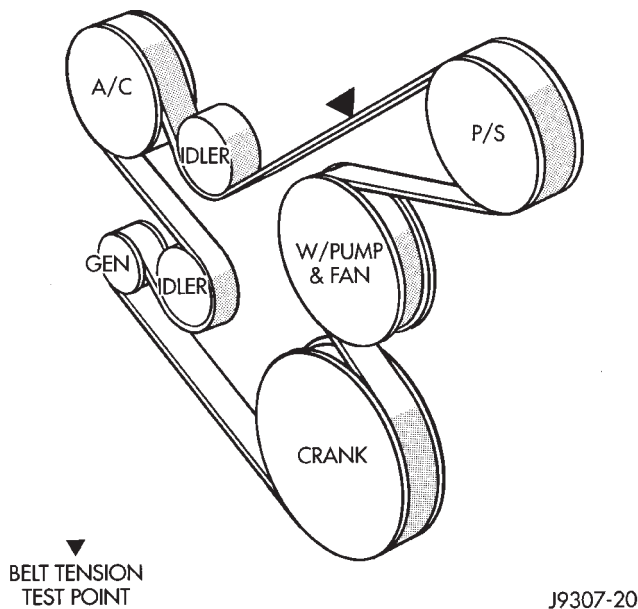

J9307-20

Fig. 2 YJ Models with 4.0L Engine and XJ Models with 2.5L Engine—With A/C

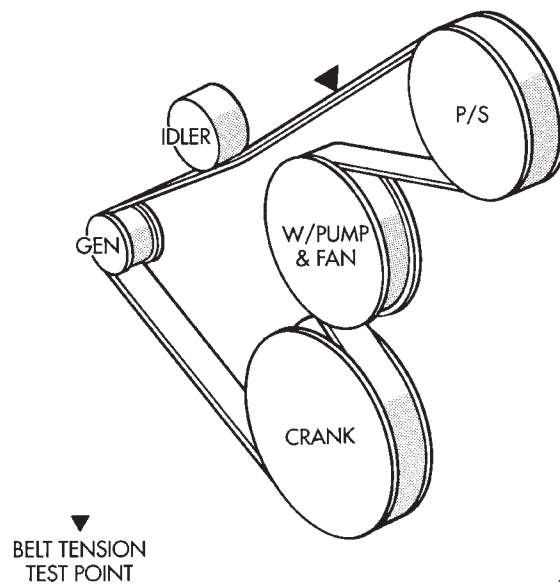

J9307-21

Fig. 3 YJ Models With 2.5L or 4.0L Engine and XJ Models with 2.5L Engine—Without A/C

BELT TENSION—RIGHT HAND DRIVE (RHD)

XJ MODELS WITH 4.0L ENGINE

It is not necessary to adjust belt tension on RHD vehicles if equipped with a 4.0L engine. The engine is equipped with an automatic belt tensioner (Fig. 7). The tensioner maintains correct belt tension at all times. **Due to the use of this belt tensioner, DO NOT attempt to use a belt tension gauge on this engine.**

BELT TENSION SPECIFICATIONS

Refer to the Specifications section at the end of this group.

BELT SCHEMATICS

The belt routing schematics are published from the latest information available at the time of publication. **If anything differs between these schematics and the Belt Routing Label, use the schematics on Belt Routing Label.** This label is located in the engine compartment.

Refer to figures 2, 3, 4 or 5 for proper belt routing on vehicles with conventional left hand drive. Refer to figure 6 for proper belt routing on vehicles with right hand drive (RHD). Or, refer to the Belt Routing Label located in the vehicle engine compartment.

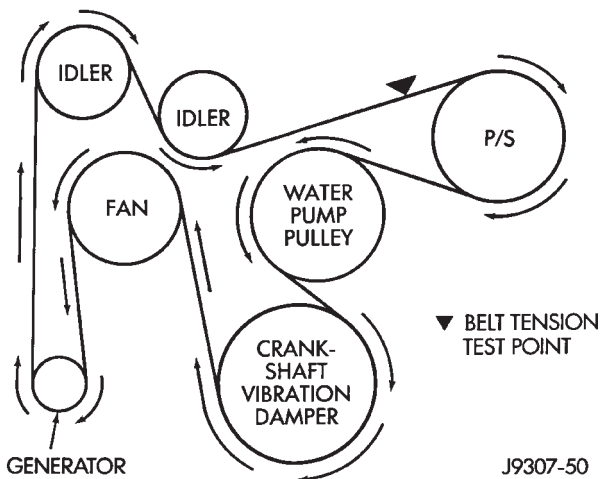

Fig. 4 XJ Models with 4.0L Engine—Without A/C—Except RHD

BELT SERVICE—EXCEPT RIGHT HAND DRIVE

The following procedures are for models equipped with conventional left hand drive. Also refer to Belt Service—With Right Hand Drive.

REPLACEMENT/ADJUSTMENT

Belt tension is adjusted at the power steering pump (or idler pulley if not equipped with power steering). To adjust belt tension or to replace belt:

(1) Loosen two rear power steering pump mounting bolts A (Fig. 8).

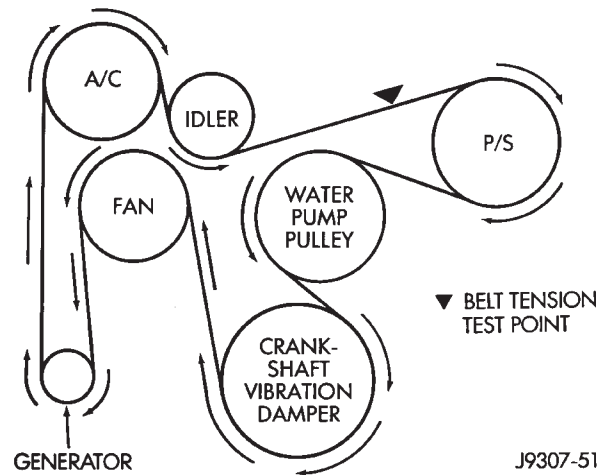

Fig. 5 XJ Models With 4.0L Engine—With A/C—Except RHD

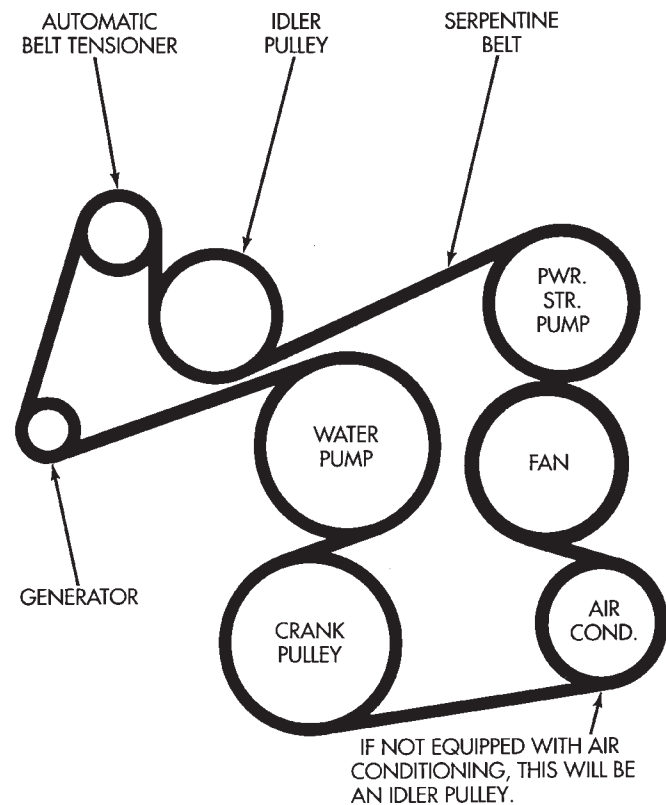

Fig. 6 XJ Models With 4.0L Engine—With A/C—With RHD

(2) Loosen upper pump pivot bolt B and lower lock nut C (Fig. 9).

(3) Loosen pump adjusting bolt D (Fig. 8).

(4) If belt is to be adjusted, refer to Drive Belt Tension specifications at the end of this group for correct tension and proceed to step 7.

If belt is to be replaced, remove belt.

(5) Check condition of all pulleys.

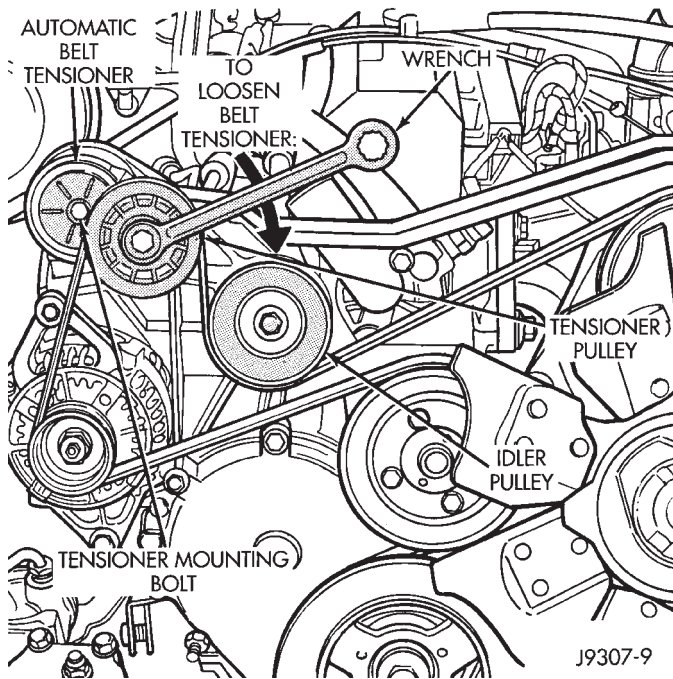

Fig. 7 Automatic Belt Tensioner—4.0L Engine With RHD

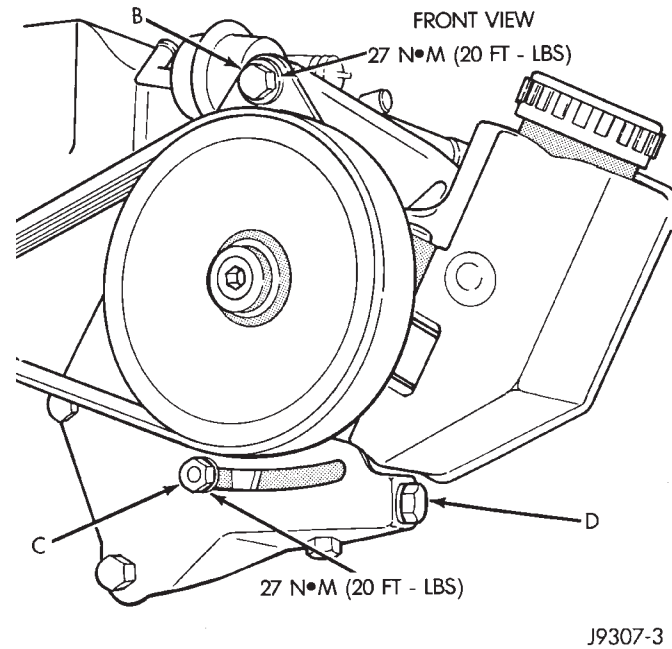

Fig. 9 P.S. Pump Front Mounting Bolt/Locknut—Typical

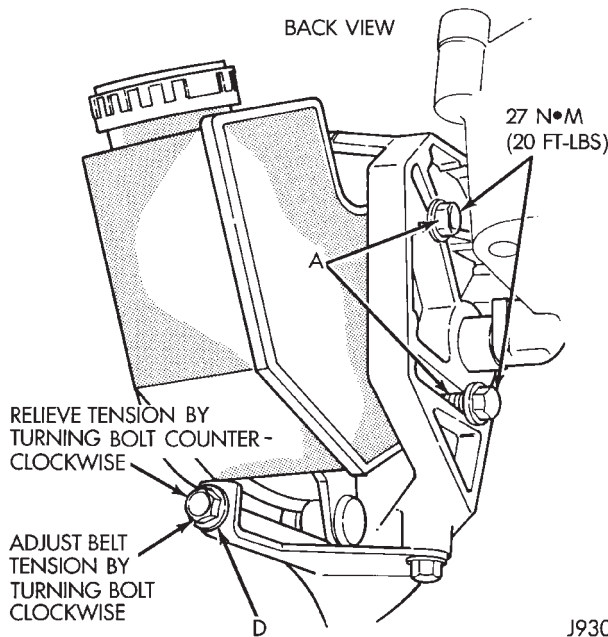

Fig. 8 P.S. Pump Rear Mounting Bolts—Typical

CAUTION: When installing the serpentine accessory drive belt, the belt **MUST** be routed correctly. If not, the engine may overheat due to the water pump rotating in the wrong direction. Refer to (Figs. 2, 3, 4 or 5) for correct belt routing.

(6) Install new belt. Refer to the end of this group for Drive Belt Tension specifications.

(7) Tighten pump adjusting bolt D (Fig. 8) to attain proper belt tension.

(8) Tighten rear pump mounting bolts, pivot bolt and lock nut to 27 N·m (20 ft. lbs.) torque.

(9) After power steering pump has been tightened into position, recheck belt tension. Adjust if necessary.

BELT SERVICE—WITH RIGHT HAND DRIVE

The following procedures are for XJ models equipped with right hand drive (RHD) and a 4.0L engine.

REMOVAL

(1) Attach a socket/wrench to the mounting bolt of the automatic tensioner pulley (Fig. 7).

(2) Rotate the tensioner assembly clockwise (as viewed from front) until tension has been relieved from belt.

(3) Remove belt from idler pulley (Fig. 7) first. Remove belt from vehicle.

(4) Check condition and alignment of all pulleys.

INSTALLATION

(1) Position the drive belt over all pulleys **except** the idler pulley (Fig. 7).

CAUTION: When installing the serpentine accessory drive belt, the belt must be routed correctly. If not, the engine may overheat due to the water pump rotating in the wrong direction. Refer to (Fig. 6) for correct engine belt routing. The correct belt with the correct length must be used

(2) Attach a socket/wrench to the pulley mounting bolt of the automatic tensioner (Fig. 7).

(3) Rotate the socket/wrench clockwise (Fig. 7). Place the belt over the idler pulley. Let tensioner rotate back into place. Remove wrench. Be sure belt is properly seated in the grooves of all pulleys.

AUTOMATIC BELT TENSIONER—XJ MODELS

4.0L ENGINE WITH RIGHT HAND DRIVE

The drive belt is equipped with a spring loaded automatic belt tensioner (Fig. 10). This belt tensioner will be used with all belt configurations such as with or without air conditioning.

REMOVAL

(1) Attach a socket/wrench to the mounting bolt of the automatic tensioner pulley (Fig. 10).

(2) Rotate the tensioner assembly clockwise (as viewed from front) until tension has been relieved from belt.

(3) Remove belt from idler pulley (Fig. 10) first. Remove belt from automatic tensioner.

(4) Remove tensioner mounting bolt (Fig. 10) from tensioner bracket. Remove tensioner from vehicle. Note alignment pin on the back of tensioner.

WARNING: BECAUSE OF HIGH SPRING PRESSURE, DO NOT ATTEMPT TO DISASSEMBLE AUTOMATIC TENSIONER. UNIT IS SERVICED AS AN ASSEMBLY (EXCEPT FOR PULLEY).

(5) Remove tensioner pulley bolt. Remove pulley from tensioner.

INSTALLATION

(1) Install pulley and pulley bolt to tensioner. Tighten bolt to 90 N·m (65 ft. lbs.) torque.

(2) Install tensioner assembly to mounting bracket. An alignment pin is located on the back of tensioner. Align this pin to the slotted hole in the mounting bracket. Install mounting bolt and tighten to 41 N·m (30 ft. lbs.) torque. If automatic tensioner bracket-to-

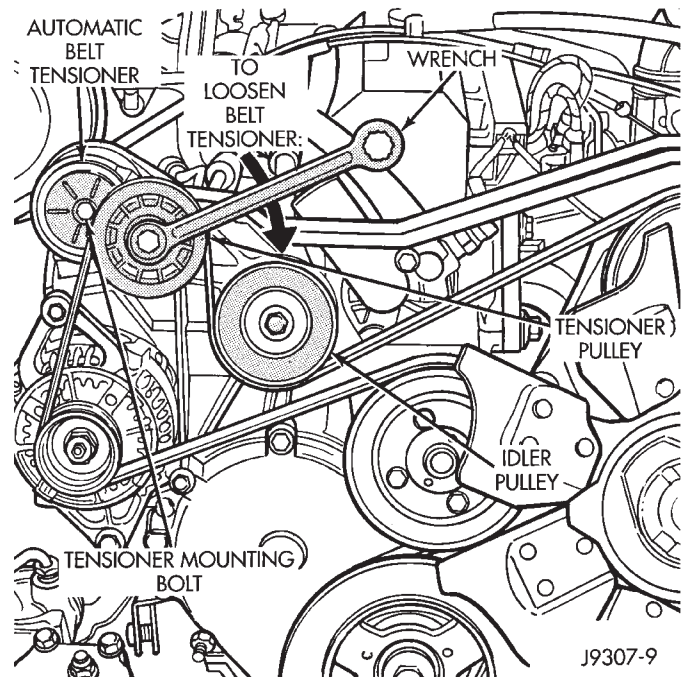

Fig. 10 Automatic Belt Tensioner—4.0L Engine With RHD

generator mounting bracket bolts were removed, tighten to 27 N·m (20 ft. lbs.) torque.

(3) Position the drive belt over all pulleys **except** the idler pulley (Fig. 10).

CAUTION: When installing the serpentine accessory drive belt, the belt must be routed correctly. If not, the engine may overheat due to the water pump rotating in the wrong direction. Refer to (Fig. 6) for correct engine belt routing. The correct belt with the correct length must be used

(4) Attach a socket/wrench to the pulley mounting bolt of the automatic tensioner (Fig. 10).

(5) Rotate the socket/wrench clockwise (Fig. 10). Place the belt over the idler pulley. Let tensioner rotate back into place. Remove wrench. Be sure belt is properly seated on all pulleys.

ENGINE BLOCK HEATER

GENERAL INFORMATION

DESCRIPTION AND OPERATION

An optional engine block heater is available for all models. The heater is equipped with a power cord. The cord is attached to an engine compartment component with tie-straps. The heater warms the engine providing easier engine starting and faster warm-up in low temperatures. The heater is mounted in a core hole of the engine cylinder block (in place of a freeze plug) with the heating element immersed in engine coolant. Connect the power cord to a grounded 110-120 volt AC electrical outlet with a grounded, three-wire extension cord.

WARNING: DO NOT OPERATE ENGINE UNLESS BLOCK HEATER CORD HAS BEEN DISCONNECTED FROM POWER SOURCE AND SECURED IN PLACE.

BLOCK HEATER SPECIFICATIONS

- 2.5L Engine: 115 Volts 400 Watts
- 4.0L Engine: 120 Volts 600 Watts

REMOVAL

Refer to correct illustration (Figures 11, 12 or 13) when servicing block heater.

WARNING: DO NOT REMOVE THE CYLINDER BLOCK DRAIN PLUGS OR LOOSEN THE RADIATOR DRAINCOCK WITH THE SYSTEM HOT AND PRESSURIZED. SERIOUS BURNS FROM THE COOLANT CAN OCCUR.

DO NOT WASTE reusable coolant. If solution is clean, drain coolant into a clean container for reuse.

- (1) Drain coolant from radiator and engine cylinder block.
- (2) Unplug power cord from block heater.
- (3) Loosen screw in center of block heater (Figs. 11, 12 or 13).
- (4) Remove block heater from cylinder block.

INSTALLATION

- (1) Thoroughly clean the engine core hole and the block heater seat.
- (2) Insert block heater assembly into core hole with element loop pointing **Up**.
- (3) Seat block heater flush against block face. Tighten mounting screw to 3.6 N·m (32 in. lbs.) torque.
- (4) Fill cooling system with coolant. Pressurize system and inspect for leaks.
- (5) Plug power cord into block heater. Route cord away from moving parts, linkages and exhaust system components. Secure cord in place with tie-straps.

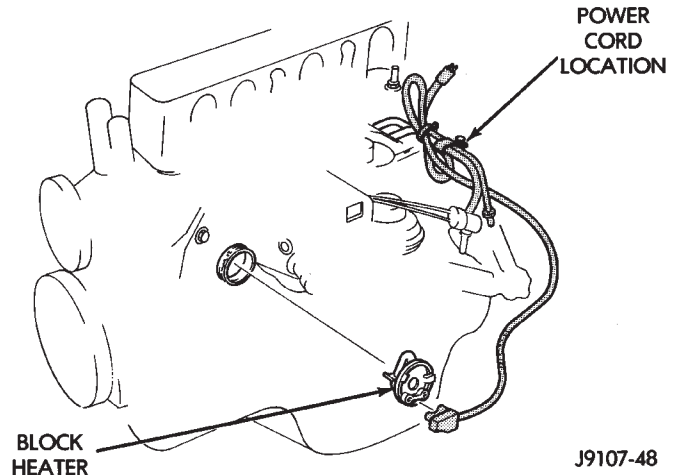

Fig. 11 Heater and Cord—XJ with 2.5L Engine

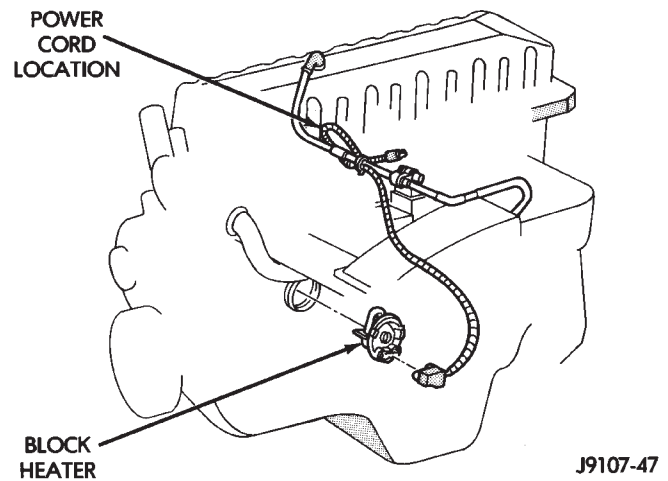

Fig. 12 Heater and Cord—XJ with 4.0L Engine

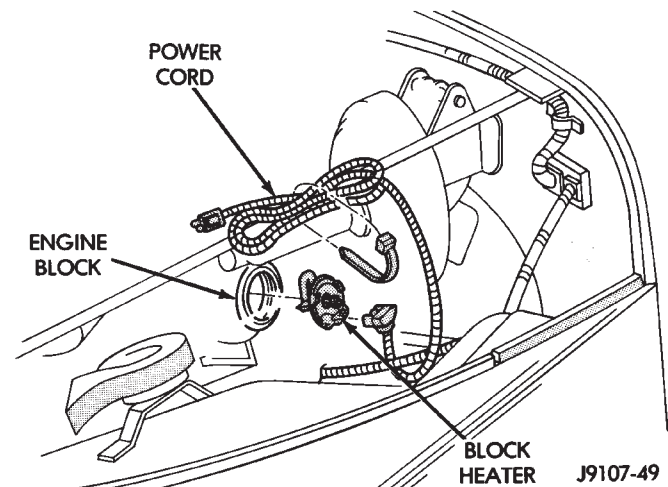

Fig. 13 Heater and Cord—YJ Models

SPECIFICATIONS

GENERAL INFORMATION

The following specifications are published from the latest information available at the time of publication. **If anything differs between the specifications found on the Vehicle Emission Control Information (VECI) label and the following specifications, use specifications on VECI label.** The VECI label is located in the engine compartment.

DRIVE BELT TENSION

Belt tension can be adjusted only on models equipped with conventional left hand drive. Refer to the following Belt Tension—Except RHD Models chart for specifications.

It is not necessary to adjust belt tension on right hand drive (RHD) vehicles if equipped with a 4.0L engine. The engine is equipped with an automatic belt tensioner. The tensioner maintains correct belt tension at all times. **Due to the use of this belt tensioner, DO NOT attempt to use a belt tension gauge on this engine.** Refer to Automatic Belt Tensioner for additional information.

BELT TENSION—EXCEPT RHD MODELS

* 800-900 N (180-200 lbs. force)
(With ** new serpentine belt)

* 623-712 N (140-160 lbs. force)
(With ** used serpentine belt)

** Belt is considered new if it has been used 15 minutes or less.

* Specifications for use with a belt tension gauge. Refer to operating instructions supplied with gauge.

J9307-54

COOLING SYSTEM CAPACITIES

MODEL	ENGINE		COOLING CAPACITY		COOLING PACKAGE		RADIATOR		A/C	MECHANICAL FAN (VISCIOUS DRIVE)			AUXILIARY* ELECTRIC FAN		
	2.5L	4.0L	QTS.	LITERS	STD.	HD.	ROWS OF TUBES	FINS PER INCH		DIA. (INCH)	NO. OF BLADES	BLADE PITCH (INCH)	DIA. (INCH)	NO. OF BLADES	BLADE PITCH (INCH)
XJ	•		10.0	9.5	•		1	15		16.0	5	2.5			
	•		10.0	9.5		•	1	20	•	16.0	5	2.5			
		•	12.0	11.4	•		1	19		15.0	7	1.88			
		•	12.0	11.4	•		1	19	•	15.0	7	1.88	11.0	6	1.75
		•	12.0	11.4		•	2	19		15.0	7	1.88	11.0	6	1.75
		•	12.0	11.4		•	2	19	•	15.0	7	1.88	11.0	6	1.75
YJ	•		9.0	8.5	•		1	15		15.0	5	2.5			
		•	10.5	9.9	•		2	15		17.25	5	2.58			
		•	10.5	9.9	•		2	15	•	17.25	5	2.58			

* 4.0L ENGINE WITH HEAVY DUTY COOLING AND/OR AIR CONDITIONING

J9407-22

TORQUE

DESCRIPTION	TORQUE
Generator Pivot Bolt	38 N•m (28 ft. lbs.)
Generator Rear Adj. Bolt	27 N•m (20 ft. lbs.)
Auto. Trans. Auxiliary Oil Cooler Mtg. Screws 4.0L	2 N•m (18 in. lbs.)
Auxiliary Electric Cooling Fan Mtg. Screws 4.0L	4 N•m (36 in. lbs.)
Condenser-to-Radiator Screws XJ Vehicles W/2.5L Eng	6 N•m (55 in. lbs.)
Fan Blade Assy.-to- Viscous Fan Drive	24 N•m (18 ft. lbs.)
Viscous Fan Drive Assy. to-Water Pump	27 N•m (20 ft. lbs.)
Fan Shroud Mtg. Bolts XJ W/2.5L	2 N•m (20 in. lbs.)
Fan Shroud Mtg. Screws YJ Vehicle	16 N•m (12 ft. lbs.)
Fan Shroud Mtg. Screws 4.0L Eng.	4 N•m (31 in. lbs.)
Engine Cyl. Block Heater	4 N•m (32 in. lbs.)
Radiator Mtg. Bolts XJ Vehicles	8 N•m (6 ft. lbs.)
Radiator Mounting Bolts XJ with 2.5L	6 N•m (55 in. lbs.)
Thermostat Housing	20 N•m (15 ft. lbs.)
Water Pump 2.5L and 4.0L	30 N•m (22 ft. lbs.)

J9407-24

