

ENGINES

CONTENTS

	page		page
2.5L ENGINE SERVICE PROCEDURES	9	ENGINE DIAGNOSIS	5
4.0L ENGINE SERVICE PROCEDURES	50	STANDARD SERVICE PROCEDURES	1

STANDARD SERVICE PROCEDURES

INDEX

	page		page
Engine Performance	2	Measuring with Plastigage	3
Form-In-Place Gaskets	1	Repair Damaged or Worn Threads	4
Honing Cylinder Bores	2	Service Engine Assembly (Short Block)	4
Hydrostatic Lock	4		

FORM-IN-PLACE GASKETS

There are several places where form-in-place gaskets are used on the engine. **DO NOT use form-in-place gasket material unless specified.** Care must be taken when applying form-in-place gaskets. Bead size, continuity and location are of great importance. Too thin a bead can result in leakage while too much can result in spill-over. A continuous bead of the proper width is essential to obtain a leak-free joint.

Two types of form-in-place gasket materials are used in the engine area (Mopar Silicone Rubber Adhesive Sealant and Mopar Gasket Maker). Each have different properties and cannot be used interchangeably.

MOPAR SILICONE RUBBER ADHESIVE SEALANT

Mopar Silicone Rubber Adhesive Sealant, normally black in color, is available in 3 ounce tubes. Moisture in the air causes the sealant material to cure. This material is normally used on flexible metal flanges. It has a shelf life of a year and will not properly cure if over aged. Always inspect the package for the expiration date before use.

MOPAR GASKET MAKER

Mopar Gasket Maker, normally red in color, is available in 6 cc tubes. This anaerobic type gasket material cures in the absence of air when squeezed between smooth machined metallic surfaces. It will not cure if left in the uncovered tube. **DO NOT** use on flexible metal flanges.

SURFACE PREPARATION

Parts assembled with form-in-place gaskets may be disassembled without unusual effort. In some instances, it may be necessary to lightly tap the part with a mallet or other suitable tool to break the seal between the mating surfaces. A flat gasket scraper may also be lightly tapped into the joint but care must be taken not to damage the mating surfaces.

Scrape or wire brush all gasket surfaces to remove all loose material. Inspect stamped parts to ensure gasket rails are flat. Flatten rails with a hammer on a flat plate, if required. Gasket surfaces must be free of oil and dirt. Make sure the old gasket material is removed from blind attaching holes.

GASKET APPLICATION

Assembling parts using a form-in-place gasket requires care.

Mopar Silicone Rubber Adhesive Sealant should be applied in a continuous bead approximately 3 mm (0.12 inch) in diameter. All mounting holes must be circled. For corner sealing, a 3 or 6 mm (1/8 or 1/4 inch) drop is placed in the center of the gasket contact area. Uncured sealant may be removed with a shop towel. Components should be torqued in place while the sealant is still wet to the touch (within 10 minutes). The use of a locating dowel is recommended during assembly to prevent smearing the material off location.

Mopar Gasket Maker should be applied sparingly to one gasket surface. The sealant diameter should be 1.00 mm (0.04 inch) or less. Be certain the material surrounds each mounting hole. Excess material

can easily be wiped off. Components should be torqued in place within 15 minutes. The use of a locating dowel is recommended during assembly to prevent smearing the material off location.

ENGINE PERFORMANCE

To provide best vehicle performance and lowest vehicle emissions, it is most important that the tune-up be done accurately. Use the specifications listed on the Vehicle Emission Control Information label found on the engine compartment hood.

- (1) Test battery specific gravity. Add water, if necessary. Clean and tighten battery connections.
- (2) Test cranking amperage draw (refer to Group 8B, Battery/Starter Service for the proper procedures).
- (3) Tighten the intake manifold bolts (refer to Group 11, Exhaust System and Intake Manifold for the proper specifications).
- (4) Perform cylinder compression test:
 - (a) Check engine oil level and add oil, if necessary.
 - (b) Drive the vehicle until engine reaches normal operating temperature.
 - (c) Select a route free from traffic and other forms of congestion, observe all traffic laws and briskly accelerate through the gears several times. The higher engine speed may help clean out valve seat deposits which can prevent accurate compression readings.

CAUTION: DO NOT overspeed the engine.

- (d) Remove all spark plugs from engine. As spark plugs are being removed, check electrodes for abnormal firing indicators - fouled, hot, oily, etc. Record cylinder number of spark plug for future reference.
- (e) Disconnect coil wire from distributor and secure to good ground to prevent a spark from starting a fire.
- (f) Be sure throttle blades are fully open during the compression check.
- (g) Insert compression gage adaptor into the No.1 spark plug hole. Crank engine until maximum pressure is reached on gauge. Record this pressure as No.1 cylinder pressure.
- (h) Repeat Step 4g for all remaining cylinders.
- (i) Compression should not be less than 689 kPa (100 psi) and not vary more than 172 kPa (25 psi) from cylinder to cylinder.
- (j) If cylinder(s) have abnormally low compression pressures, repeat steps 4a through 4h.
- (k) If the same cylinder(s) repeat an abnormally low reading, it could indicate the existence of a problem in the cylinder.

The recommended compression pressures are to be used only as a guide to diagnosing engine

problems. An engine should NOT be disassembled to determine the cause of low compression unless some malfunction is present.

- (5) Clean or replace spark plugs as necessary. Adjust gap (refer to Group 8D, Ignition System for gap adjustment and torque).
- (6) Test resistance of spark plug cables (refer to Group 8D, Ignition System).
- (7) Inspect the primary wire. Test coil output voltage, primary and secondary resistance. Replace parts as necessary (refer to Group 8D, Ignition System and make necessary adjustment).
- (8) Set ignition timing to specifications (refer to Specification Label on engine compartment hood).
- (9) Perform a combustion analysis.
- (10) Test fuel pump for pressure and vacuum (refer to Group 14, Fuel System for the proper specifications).
- (11) Inspect air filter element (refer to Group 0, Lubrication and Maintenance for the proper procedure).
- (12) Inspect crankcase ventilation system (refer to Group 0, Lubrication and Maintenance for the proper procedure).
- (13) For emission controls refer to Group 25, Emission Controls System for service procedures.
- (14) Inspect and adjust accessory belt drives (refer to Group 7, Cooling System for the proper adjustments).
- (15) Road test vehicle as a final test.

HONING CYLINDER BORES

Before honing, stuff plenty of clean shop towels under the bores and over the crankshaft to keep abrasive materials from entering the crankshaft area.

- (1) Used carefully, the Cylinder Bore Sizing Hone C-823 equipped with 220 grit stones, is the best tool for this job. In addition to deglazing, it will reduce taper and out-of-round as well as removing light scuffing, scoring or scratches. Usually a few strokes will clean up a bore and maintain the required limits.

CAUTION: DO NOT use rigid type hones to remove cylinder wall glaze.

- (2) Deglazing of the cylinder walls may be done if the cylinder bore is straight and round. Use a cylinder surfacing hone, Honing Tool C-3501, equipped with 280 grit stones (C-3501-3810). 20-60 strokes, depending on the bore condition, will be sufficient to provide a satisfactory surface. Using honing oil C-3501-3880 or a light honing oil available from major oil distributors.

CAUTION: DO NOT use engine or transmission oil, mineral spirits or kerosene.

(3) Honing should be done by moving the hone up and down fast enough to get a crosshatch pattern. The hone marks should INTERSECT at 50° to 60° for proper seating of rings (Fig. 1).

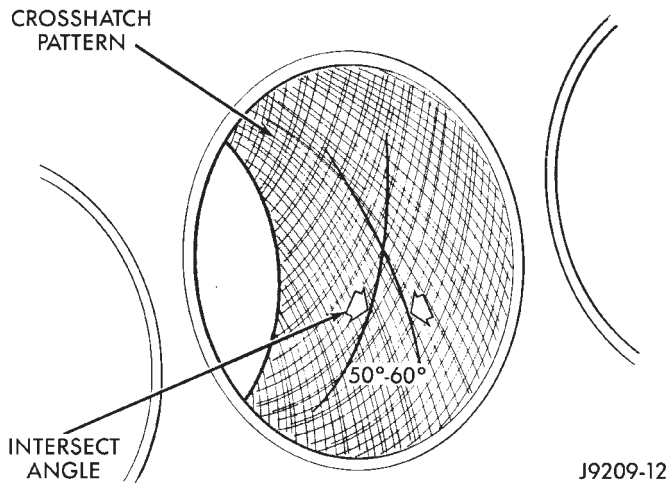

Fig. 1 Cylinder Bore Crosshatch Pattern

(4) A controlled hone motor speed between 200 and 300 RPM is necessary to obtain the proper crosshatch angle. The number of up and down strokes per minute can be regulated to get the desired 50° to 60° angle. Faster up and down strokes increase the crosshatch angle.

(5) After honing, it is necessary that the block be cleaned to remove all traces of abrasive. Use a brush to wash parts with a solution of hot water and detergent. Dry parts thoroughly. Use a clean, white, lint-free cloth to check that the bore is clean. Oil the bores after cleaning to prevent rusting.

MEASURING WITH PLASTIGAGE

CRANKSHAFT MAIN BEARING CLEARANCE

Engine crankshaft bearing clearances can be determined by use of Plastigage, or equivalent. The following is the recommended procedures for the use of Plastigage:

(1) Remove oil film from surface to be checked. Plastigage is soluble in oil.

(2) The total clearance of the main bearings can only be determined by removing the weight of the crankshaft. This can be accomplished by either of two methods:

METHOD - 1 (PREFERRED)—Shim the bearings adjacent to the bearing to be checked. This will remove the clearance between upper bearing shell and the crankshaft. Place a minimum of 0.254 mm (0.010 inch) shim between the bearing shell and the adjacent bearing cap. Tighten the bolts to 18 N·m (13 ft. lbs.) torque.

• **ALL ENGINES**—When checking No.1 main bearing; shim No.2 main bearing.

• **ALL ENGINES**—When checking No.2 main bearing; shim No.1 and No.3 main bearing.

• **ALL ENGINES**—When checking No.3 main bearing; shim No.2 and No.4 main bearing.

• **ALL ENGINES**—When checking No.4 main bearing; shim No.3 and No.5 main bearing.

• **2.5L ENGINE**—When checking No.5 main bearing; shim No.4 main bearing.

• **4.0L ENGINE**—When checking No.5 main bearing; shim No.4 and No.6 main bearing.

• **4.0L ENGINE**—When checking No.6 main bearing; shim No.5 and No.7 main bearing.

• **4.0L ENGINE**—When checking No.7 main bearing; shim No.6 main bearing.

Remove all shims before assembling engine.

METHOD - 2 (ALTERNATIVE)—The weight of the crankshaft is supported by a jack under the counterweight adjacent to the bearing being checked.

(3) Place a piece of Plastigage across the entire width of the bearing cap shell (Fig. 2). Position the Plastigage approximately 6.35 mm (1/4 inch) off center and away from the oil holes. In addition, suspect areas can be checked by placing the Plastigage in that area. Tighten the bearing cap bolts of the bearing being checked to 108 N·m (80 ft. lbs.) torque. **DO NOT rotate the crankshaft or the Plastigage may be smeared, giving inaccurate results.**

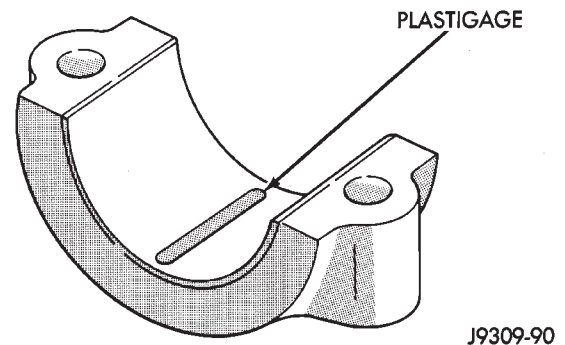

Fig. 2 Placement of Plastigage in Bearing Shell

(4) Remove the bearing cap and compare the width of the flattened Plastigage with the scale provided on the package (Fig. 3). Plastigage generally comes in 2 scales (one scale is in inches and the other is a metric scale). Locate the band closest to the same width. This band shows the amount of clearance. Differences in readings between the ends indicate the amount of taper present. Record all readings taken (refer to Engine Specifications).

(5) Plastigage is available in a variety of clearance ranges. The 0.025-0.076 mm (0.001-0.003 inch) range is usually the most appropriate for checking engine bearing clearances.

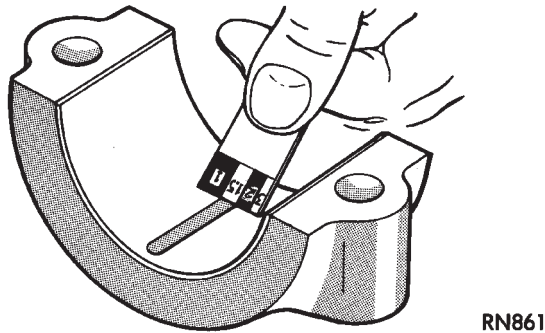

Fig. 3 Clearance Measurement

CONNECTING ROD BEARING CLEARANCE

Engine connecting rod bearing clearances can be determined by use of Plastigage, or equivalent. The following is the recommended procedures for the use of Plastigage:

(1) Remove oil film from surface to be checked. Plastigage is soluble in oil.

(2) Place a piece of Plastigage across the entire width of the bearing cap shell (Fig. 2). Position the Plastigage approximately 6.35 mm (1/4 inch) off center and away from the oil holes. In addition, suspect areas can be checked by placing the Plastigage in the suspect area.

(3) The crankshaft must be turned until the connecting rod to be checked starts moving toward the top of the engine. Only then should the rod cap with Plastigage in place be assembled. Tighten the rod cap nut to 45 N·m (33 ft. lbs.) torque. **DO NOT rotate the crankshaft or the Plastigage may be smeared, giving inaccurate results.**

(4) Remove the bearing cap and compare the width of the flattened Plastigage with the scale provided on the package (Fig. 3). Plastigage generally comes in 2 scales (one scale is in inches and the other is a metric scale). Locate the band closest to the same width. This band shows the amount of clearance. Differences in readings between the ends indicate the amount of taper present. Record all readings taken (refer to Engine Specifications).

(5) Plastigage is available in a variety of clearance ranges. The 0.025-0.076 mm (0.001-0.003 inch) range is usually the most appropriate for checking engine bearing clearances.

REPAIR DAMAGED OR WORN THREADS

Damaged or worn threads can be repaired. Essentially, this repair consists of:

- Drilling out worn or damaged threads.
- Tapping the hole with a special Heli-Coil Tap, or equivalent.
- Installing an insert into the tapped hole.

This brings the hole back to its original thread size.

CAUTION: Be sure that the tapped holes maintain the original center line.

Heli-Coil tools and inserts are readily available from automotive parts jobbers.

SERVICE ENGINE ASSEMBLY (SHORT BLOCK)

A service replacement engine assembly (short block) may be installed whenever the original cylinder block is defective or damaged beyond repair. It consists of the cylinder block, crankshaft, piston and rod assemblies. If needed, the camshaft must be procured separately and installed before the engine is installed in the vehicle.

A short block is identified with the letter "S" stamped on the same machined surface where the build date code is stamped for complete engine assemblies.

Installation includes the transfer of components from the defective or damaged original engine. Follow the appropriate procedures for cleaning, inspection and torque tightening.

HYDROSTATIC LOCK

When an engine is suspected of hydrostatic lock (regardless of what caused the problem), follow the steps below.

- (1) Perform the Fuel Pressure Release Procedure (refer to Group 14, Fuel System).
- (2) Disconnect the negative cable from the battery.
- (3) Inspect air cleaner, induction system and intake manifold to ensure system is dry and clear of foreign material.
- (4) Place a shop towel around the spark plugs to catch any fluid that may possibly be under pressure in the cylinder head. Remove the plugs from the engine.

CAUTION: DO NOT use the starter motor to rotate the crankshaft. Severe damage could occur.

- (5) With all spark plugs removed, rotate the crankshaft using a breaker bar and socket.
- (6) Identify the fluid in the cylinders (i.e. coolant, fuel, oil, etc.).
- (7) Make sure all fluid has been removed from the cylinders.
- (8) Repair engine or components as necessary to prevent this problem from occurring again.
- (9) Squirt engine oil into the cylinders to lubricate the walls. This will prevent damage on restart.
- (10) Install new spark plugs. Tighten the spark plugs to 37 N·m (27 ft. lbs.) torque.
- (11) Drain engine oil. Remove and discard the oil filter.
- (12) Install the drain plug. Tighten the plug to 34 N·m (25 ft. lbs.) torque.
- (13) Install a new oil filter.
- (14) Fill engine crankcase with the specified amount and grade of oil (refer to Group 0, Lubrication and Maintenance).
- (15) Connect the negative cable to the battery.
- (16) Start the engine and check for any leaks.

ENGINE DIAGNOSIS

Engine diagnosis is helpful in determining the causes of malfunctions not detected and remedied by routine tune-ups.

These malfunctions may be classified as either performance (e.g., engine idles rough and stalls) or mechanical (e.g., a strange noise).

Refer to the Service Diagnosis—Performance chart and the Service Diagnosis—Mechanical chart for possible causes and corrections of malfunctions. Refer to Group 14, Fuel System for the fuel system diagnosis.

Additional tests and diagnostic procedures may be necessary for specific engine malfunctions that can not be isolated with the Service Diagnosis charts. Information concerning additional tests and diagnosis is provided within the following diagnosis:

- Cylinder Compression Pressure Test.
- Cylinder Combustion Pressure Leakage Test.
- Engine Cylinder Head Gasket Failure Diagnosis.
- Intake Manifold Leakage Diagnosis.

INTAKE MANIFOLD LEAKAGE DIAGNOSIS

An intake manifold air leak is characterized by lower than normal manifold vacuum. Also, one or more cylinders may not be functioning.

WARNING: USE EXTREME CAUTION WHEN THE ENGINE IS OPERATING. DO NOT STAND IN A DIRECT LINE WITH THE FAN. DO NOT PUT YOUR HANDS NEAR THE PULLEYS, BELTS OR THE FAN. DO NOT WEAR LOOSE CLOTHING.

METHOD 1

- (1) Start the engine.
- (2) Open the acetylene valve of an oxyacetylene torch. DO NOT ignite.
- (3) Pass the torch tip over the exposed gasket area (EDGE) between the manifold and the engine cylinder head.
- (4) If the engine speed increases, the manifold has an air leak.

METHOD 2

- (1) Start the engine.
- (2) Apply engine oil to the exposed gasket area (EDGE) between the manifold and the engine cylinder head.
- (3) If oil is forced into the manifold and if smoke is visible from the exhaust tailpipe, the manifold has an air leak.

CYLINDER COMPRESSION PRESSURE TEST

The results of a cylinder compression pressure test can be utilized to diagnose several engine malfunctions.

Ensure the battery is completely charged and the engine starter motor is in good operating condition.

Otherwise the indicated compression pressures may not be valid for diagnosis purposes.

- (1) Clean the spark plug recesses with compressed air.
- (2) Remove the spark plugs.
- (3) Secure the throttle in the wide-open position.
- (4) Disconnect the ignition coil.
- (5) Insert a compression pressure gauge and rotate the engine with the engine starter motor for three revolutions.
- (6) Record the compression pressure on the 3rd revolution. Continue the test for the remaining cylinders.

Refer to Engine Specifications for the correct engine compression pressures.

ENGINE CYLINDER HEAD GASKET FAILURE DIAGNOSIS

A leaking engine cylinder head gasket usually results in loss of power, loss of coolant and engine misfiring.

An engine cylinder head gasket leak can be located between adjacent cylinders or between a cylinder and the adjacent water jacket.

- An engine cylinder head gasket leaking between adjacent cylinders is indicated by a loss of power and/or engine misfire.
- An engine cylinder head gasket leaking between a cylinder and an adjacent water jacket is indicated by coolant foaming or overheating and loss of coolant.

CYLINDER-TO-CYLINDER LEAKAGE TEST

To determine if an engine cylinder head gasket is leaking between adjacent cylinders; follow the procedures outlined in Cylinder Compression Pressure Test. An engine cylinder head gasket leaking between adjacent cylinders will result in approximately a 50-70% reduction in compression pressure.

CYLINDER-TO-WATER JACKET LEAKAGE TEST

WARNING: USE EXTREME CAUTION WHEN THE ENGINE IS OPERATING. DO NOT STAND IN A DIRECT LINE WITH THE FAN. DO NOT PUT YOUR HANDS NEAR THE PULLEYS, BELTS OR THE FAN. DO NOT WEAR LOOSE CLOTHING.

Remove the radiator cap.

Start the engine and allow it to warm up until the engine thermostat opens.

If a large combustion/compression pressure leak exists, bubbles will be visible in the coolant.

If bubbles are not visible, install a radiator pressure tester and pressurize the coolant system.

If a cylinder is leaking combustion pressure into the water jacket, the tester pointer will pulsate with every combustion stroke of the cylinder.

CYLINDER COMBUSTION PRESSURE LEAKAGE TEST

The combustion pressure leakage test provides an accurate means for determining engine condition.

Combustion pressure leakage testing will detect:

- Exhaust and intake valve leaks (improper seating).
- Leaks between adjacent cylinders or into water jacket.
- Any causes for combustion/compression pressure loss.

WARNING: DO NOT REMOVE THE RADIATOR CAP WITH THE SYSTEM HOT AND UNDER PRESSURE BECAUSE SERIOUS BURNS FROM COOLANT CAN OCCUR.

Check the coolant level and fill as required. DO NOT install the radiator cap.

Start and operate the engine until it attains normal operating temperature, then turn the engine OFF.

Remove the spark plugs.

Remove the oil filler cap.

Remove the air cleaner.

Calibrate the tester according to the manufacturer's instructions. The shop air source for testing should maintain 483 kPa (70 psi) minimum, 1 379 kPa (200 psi) maximum and 552 kPa (80 psi) recommended.

Perform the test procedures on each cylinder according to the tester manufacturer's instructions. While testing, listen for pressurized air escaping through the throttle body, tailpipe and oil filler cap opening. Check for bubbles in the radiator coolant.

All gauge pressure indications should be equal, with no more than 25% leakage.

FOR EXAMPLE: At 552 kPa (80 psi) input pressure, a minimum of 414 kPa (60 psi) should be maintained in the cylinder.

Refer to the Cylinder Combustion Pressure Leakage Test Diagnosis chart.

CYLINDER COMBUSTION PRESSURE LEAKAGE TEST DIAGNOSIS

CONDITION	POSSIBLE CAUSE	CORRECTION
AIR ESCAPES THROUGH CARBURETOR/THROTTLE BODY	Intake valve not seated properly.	Inspect valve. Reface or replace, if necessary.
AIR ESCAPES THROUGH TAILPIPE	Exhaust valve not seated properly.	Inspect valve. Reface or replace, if necessary.
AIR ESCAPES THROUGH RADIATOR	Head gasket leaks or crack in cylinder block.	Remove cylinder head and inspect. Replace, if necessary.
MORE THAN 50% LEAKAGE FROM ADJACENT CYLINDERS	Head gasket leaks or crack in cylinder block or head between adjacent cylinders.	Remove cylinder head and inspect. Replace gasket or head, if necessary.
MORE THAN 25% LEAKAGE AND AIR ESCAPES THROUGH OIL FILLER CAP OPENING ONLY	Stuck or broken piston ring(s); cracked piston; worn rings and/or cylinder wall.	Inspect for broken ring(s) or piston. Measure ring gap and cylinder diameter, taper, and out-of-round. Replace affected part, if necessary.

SERVICE DIAGNOSIS—PERFORMANCE

CONDITION	POSSIBLE CAUSES	CORRECTION
ENGINE WILL NOT START	<ol style="list-style-type: none"> 1. Weak battery. 2. Corroded or loose battery connections. 3. Faulty starter. 4. Moisture on ignition wires and distributor cap. 5. Faulty ignition cables. 6. Faulty coil or control unit. 7. Incorrect spark plug gap. 8. Incorrect ignition timing. 9. Dirt or water in fuel system. 10. Faulty fuel pump. 	<ol style="list-style-type: none"> 1. Test battery specific gravity. Charge or replace as necessary. 2. Clean and tighten battery connections. Apply a coat of light mineral grease to the terminals. 3. Refer to Group 8A, Battery/Starter/Charging System Diagnostics. 4. Wipe wires and cap clean and dry. 5. Replace any cracked or shorted cables. 6. Test and replace, if necessary (refer to Group 8D, Ignition System). 7. Set gap (refer to Group 8D, Ignition System). 8. Refer to Group 8D, Ignition System. 9. Clean system and replace fuel filter. 10. Install new fuel pump (refer to Group 14, Fuel System).
ENGINE STALLS OR ROUGH IDLE	<ol style="list-style-type: none"> 1. Idle speed set too low. 2. Idle mixture too lean or too rich. 3. Leak in intake manifold. 4. Worn or burned distributor rotor. 5. Incorrect ignition wiring. 6. Faulty coil. 7. EGR valve leaking. 	<ol style="list-style-type: none"> 1. Refer to Group 14, Fuel System. 2. Refer to Group 14, Fuel System. 3. Inspect intake manifold gasket and vacuum hoses. Replace, if necessary (refer to Group 11, Exhaust System & Intake Manifold). 4. Install new distributor rotor. 5. Install correct wiring. 6. Test and replace, if necessary (refer to Group 8D, Ignition System). 7. Test and replace, if necessary (refer to Group 25, Emissions Control System).
ENGINE LOSS OF POWER	<ol style="list-style-type: none"> 1. Incorrect ignition timing. 2. Worn or burned distributor rotor. 3. Worn distributor shaft. 4. Dirty or incorrectly gapped spark plugs. 5. Dirt or water in fuel system. 6. Faulty fuel pump. 7. Incorrect valve timing. 8. Blown cylinder head gasket. 9. Low compression. 10. Burned, warped or pitted valves. 11. Plugged or restricted exhaust system. 12. Faulty ignition cables. 13. Faulty coil. 	<ol style="list-style-type: none"> 1. Refer to Group 8D, Ignition System. 2. Install new distributor rotor. 3. Remove and repair distributor (refer to Group 8D, Ignition System). 4. Clean plugs and set gap (refer to Group 8D, Ignition System). 5. Clean system and replace fuel filter. 6. Install new fuel pump. 7. Correct valve timing. 8. Install new cylinder head gasket. 9. Test compression of each cylinder. 10. Install new valves. 11. Install new parts, as necessary. 12. Replace any cracked or shorted cables. 13. Test and replace, as necessary (refer to Group 8D, Ignition System).
ENGINE MISSES ON ACCELERATION	<ol style="list-style-type: none"> 1. Dirty or gap set too wide in spark plug. 2. Incorrect ignition timing. 3. Dirt in fuel system. 4. Burned, warped or pitted valves. 5. Faulty coil. 	<ol style="list-style-type: none"> 1. Clean spark plugs and set gap (refer to Group 8D, Ignition System). 2. Refer to Group 8D, Ignition System. 3. Clean fuel system. 4. Install new valves. 5. Test and replace, if necessary, (refer to Group 8D, Ignition System).
ENGINE MISSES AT HIGH SPEED	<ol style="list-style-type: none"> 1. Dirty or gap set too wide in spark plug. 2. Worn distributor shaft. 3. Worn or burned distributor rotor. 4. Faulty coil. 5. Incorrect ignition timing. 6. Dirty injector in throttle body. 7. Dirt or water in fuel system. 	<ol style="list-style-type: none"> 1. Clean spark plugs and set gap (refer to Group 8D, Ignition System). 2. Remove and repair distributor (refer to Group 8D, Ignition System). 3. Install new distributor rotor. 4. Test and replace, as necessary (refer to Group 8D, Ignition System). 5. Refer to Group 8D, Ignition System. 6. Clean injector. 7. Clean system and replace fuel filter.

SERVICE DIAGNOSIS—MECHANICAL

CONDITION	POSSIBLE CAUSES	CORRECTION
NOISY VALVES	<ol style="list-style-type: none"> 1. High or low oil level in crankcase. 2. Thin or diluted oil. 3. Low oil pressure. 4. Dirt in tappets 5. Bent push rods. 6. Worn rocker arms. 7. Worn tappets. 8. Worn valve guides. 9. Excessive runout of valve seats on valve faces. 	<ol style="list-style-type: none"> 1. Check for correct oil level (refer to Group 0, Lubrication and Maintenance). 2. Change oil (refer to Group 0, Lubrication and Maintenance). 3. Check engine oil level. 4. Clean hydraulic tappets. 5. Install new push rods. 6. Inspect oil supply to rocker arms. 7. Install new hydraulic tappets. 8. Ream and install new valves with oversize stems. 9. Grind valve seats and valves.
CONNECTING ROD NOISE	<ol style="list-style-type: none"> 1. Insufficient oil supply. 2. Low oil pressure. 3. Thin or diluted oil. 4. Excessive bearing clearance. 5. Connecting rod journal out-of-round. 6. Misaligned connecting rods. 	<ol style="list-style-type: none"> 1. Check engine oil level (refer to Group 0, Lubrication and Maintenance). 2. Check engine oil level. Inspect oil pump relief valve and spring. 3. Change oil to correct viscosity. 4. Measure bearings for correct clearance. Repair as necessary. 5. Replace crankshaft or grind journals. 6. Replace bent connecting rods.
MAIN BEARING NOISE	<ol style="list-style-type: none"> 1. Insufficient oil supply. 2. Low oil pressure. 3. Thin or diluted oil. 4. Excessive bearing clearance. 5. Excessive end play. 6. Crankshaft journal out-of-round, worn. 7. Loose flywheel or torque converter. 	<ol style="list-style-type: none"> 1. Check engine oil level (refer to Group 0, Lubrication and Maintenance). 2. Check engine oil level. Inspect oil pump relief valve and spring. 3. Change oil to correct viscosity. 4. Measure bearings for correct clearance. Repair as necessary. 5. Check No. 3 main bearing for wear on flanges. 6. Grind journals or replace crankshaft. 7. Tighten to correct torque.
OIL PRESSURE DROP	<ol style="list-style-type: none"> 1. Low oil level. 2. Faulty oil pressure sending unit. 3. Low oil pressure. 4. Clogged oil filter. 5. Worn parts in oil pump. 6. Thin or diluted oil. 7. Excessive bearing clearance. 8. Oil pump relief valve stuck. 9. Oil pump suction tube loose, bent or cracked 10. Oil pump cover warped or cracked. 	<ol style="list-style-type: none"> 1. Check engine oil level. 2. Install new sending unit. 3. Check sending unit and check main bearing oil clearance. 4. Install new oil filter. 5. Replace worn parts or pump. 6. Change oil to correct viscosity. 7. Measure bearings for correct clearance. 8. Remove valve and inspect, clean and install. 9. Remove oil pan and install new tube, if necessary. 10. Install new oil pump.
OIL LEAKS	<ol style="list-style-type: none"> 1. Misaligned or deteriorated gaskets. 2. Loose fastener, broken or porous metal part. 	<ol style="list-style-type: none"> 1. Replace the gasket. 2. Tighten, repair or replace the part.
OIL PUMPING AT RINGS; SPARK PLUGS FOULING	<ol style="list-style-type: none"> 1. Worn, scuffed or broken rings. 2. Carbon in oil ring slot. 3. Rings fitted too tightly in grooves. 4. Worn valve guides. 5. Leaking intake gasket. 6. Leaking valve guide seals. 7. Dislodged valve guide seals. 	<ol style="list-style-type: none"> 1. Hone cylinder bores and install new rings. 2. Install new rings. 3. Remove the rings. Check grooves. If grooves are not proper width, replace piston. 4. Ream guides and replace valves with oversize valves and seals. 5. Replace gasket and tighten intake manifold to proper torque. 6. Replace seals. 7. Seat valve guide seals or replace, as needed.

2.5L ENGINE SERVICE PROCEDURES

INDEX

	page		page
Camshaft	29	Oil Pan	32
Camshaft Pin Replacement	31	Oil Pump	33
Crankshaft Main Bearings	40	Pistons and Connecting Rods	34
Cylinder Block	45	Rear Main Oil Seals	44
Engine Assembly—XJ Vehicles	14	Rocker Arms	19
Engine Assembly—YJ Vehicles	16	Specifications	47
Engine Cylinder Head	19	Timing Case Cover	27
Engine Cylinder Head Cover	18	Timing Case Cover Oil Seal Replacement	26
Engine Damper	13	Timing Chain and Sprockets	28
Engine Mount—Rear	12	Valve Springs and Oil Seals	21
Engine Mounts—Front	10	Valve Timing	26
General Information	9	Valves and Valve Springs	22
Hydraulic Tappets	24	Vibration Damper	26

GENERAL INFORMATION

The 2.5 liter (150 CID) four-cylinder engine is an In-line, lightweight, overhead valve engine (Fig. 1).

Engine Type	In-line 4 Cylinder
Bore and Stroke	98.4 × 81.0 mm (3.88 × 3.19 in.)
Displacement	2.5L (150 cu. in.)
Compression Ratio	9.1:1
Torque	
(XJ Vehicles)	202 N·m (149 ft. lbs.) @ 3250 rpm
(YJ Vehicles)	189 N·m (139 ft. lbs.) @ 3250 rpm
Firing Order	1-3-4-2
Lubrication	Pressure Feed—Full Flow Filtration
Engine Oil Capacity	3.8L (4 Quarts)
Cooling System	Liquid Cooled—Forced Circulation
Cooling System Capacity	
(XJ Vehicles)	9.5L (10 Quarts)
(YJ Vehicles)	8.5L (9 Quarts)
Cylinder Block	Cast Iron
Crankshaft	Cast Nodular Iron
Cylinder Head	Cast Nodular Iron
Camshaft	Cast Nodular Iron
Pistons	Aluminum Alloy (with Struts)
Pistons Combustion	
Cavity	Double Quench
Connecting Rods	Cast Nodular Iron

J9409-19

Fig. 1 Engine Description

This engine is designed for unleaded fuel.

The engine cylinder head has dual quench-type combustion chambers that create turbulence and fast burning of the air/fuel mixture. This results in good fuel economy.

The cylinders are numbered 1 through 4 from front to rear. The firing order is 1-3-4-2 (Fig. 2).

The crankshaft rotation is clockwise, when viewed from the front of the engine. The crankshaft rotates within five main bearings and the camshaft rotates within four bearings.

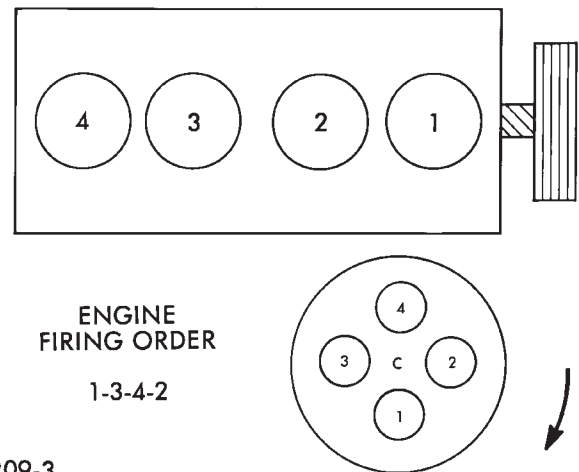

J9209-3

Fig. 2 Engine Firing Order

BUILD DATE CODE

The engine Build Date Code is located on a machined surface on the right side of the cylinder block between the No.3 and No.4 cylinders (Fig. 3).

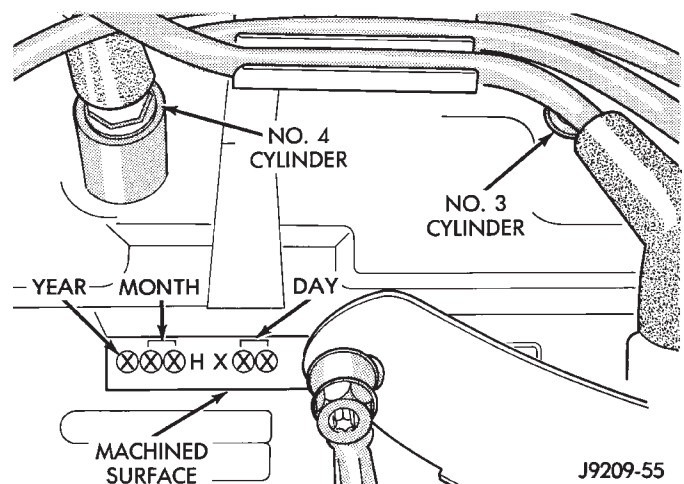

J9209-55

Fig. 3 Build Date Code Location

The digits of the code identify:

- (1) 1st Digit—The year (4 = 1994).
- (2) 2nd & 3rd Digits—The month (01 - 12).
- (3) 4th & 5th Digits—The engine type/fuel system/compression ratio (HX = A 2.5 liter (150 CID) 9.1:1 compression ratio engine with a multi-point fuel injection system).
- (4) 6th & 7th Digits—The day of engine build (01 - 31).

FOR EXAMPLE: Code * 401HX23 * identifies a 2.5 liter (150 CID) engine with a multi-point fuel injection system, 9.1:1 compression ratio and built on January 23, 1994.

OVERSIZE AND UNDERSIZE COMPONENT CODES

Some engines may be built with oversize or undersize components such as:

- Oversize cylinder bores.
- Oversize camshaft bearing bores.
- Undersize crankshaft main bearing journals.
- Undersize connecting rod journals.

These engines are identified by a letter code (Fig. 4) stamped on the oil filter boss near the distributor (Fig. 5).

CODE	COMPONENT	UNDERSIZE
P	One or more connecting rod bearing journals	0.254 mm (0.010 in)
M	All crankshaft main bearing journals	0.254 mm (0.010 in)
PM	All crankshaft main bearing journals and one or more connecting rod journals	0.254 mm (0.010 in)
CODE	COMPONENT	OVERSIZE
B	All cylinder bores	0.254 mm (0.010 in)
C	All camshaft bearing bores	0.254 mm (0.010 in)

J8909-54

Fig. 4 Oversize and Undersize Component Codes

ENGINE MOUNTS—FRONT

The front mounts support the engine at each side. These supports are made of resilient rubber.

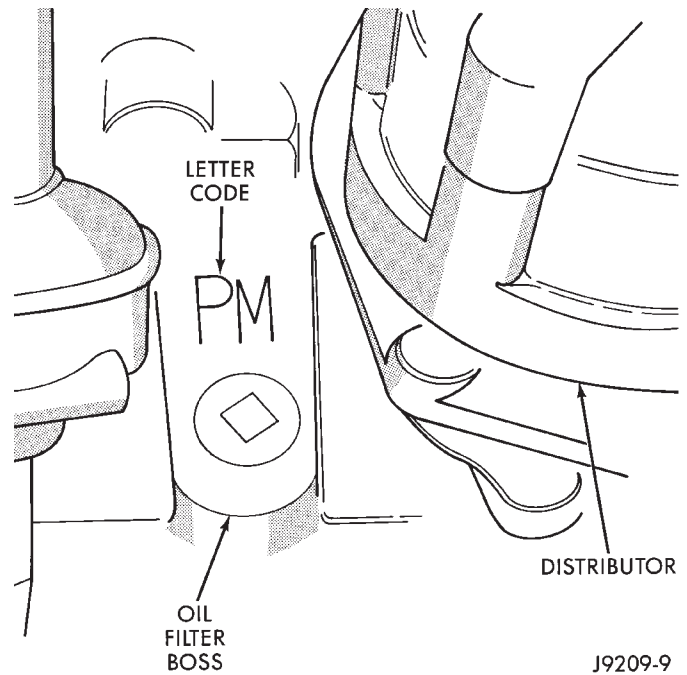

J9209-9

Fig. 5 Oversize and Undersize Component Code Location

REMOVAL—XJ VEHICLES

- (1) Disconnect negative cable from battery.
- (2) Raise the vehicle.
- (3) Support the engine.
- (4) Remove through bolt nut (Fig. 6). DO NOT remove the through bolt.
- (5) Remove the retaining bolts/nuts from the support cushions (Fig. 6).
- (6) Remove the through bolt.
- (7) Remove the support cushions.

INSTALLATION—XJ VEHICLES

- (1) If the engine support bracket was removed, position the LEFT bracket (Fig. 6) and the RIGHT bracket with generator brace (Fig. 7) onto the cylinder block. Install the bolts and stud nuts.
 - (a) RIGHT SIDE (Fig. 7)—Tighten the bolts to 61 N·m (45 ft. lbs.) torque. Tighten the stud nuts to 46 N·m (34 ft. lbs.) torque.
 - (b) LEFT SIDE (Fig. 6)—Tighten the bolts to 61 N·m (45 ft. lbs.) torque.
- (2) If the support cushion brackets were removed, position the brackets onto the lower front sill (Figs. 6 and 8). Install the bolts and stud nuts. Tighten the bolts to 54 N·m (40 ft. lbs.) torque and the stud nuts to 41 N·m (30 ft. lbs.) torque.
- (3) Place the support cushions onto the support cushion brackets (Fig. 6). Tighten the right support cushion nuts to 65 N·m (48 ft. lbs.) torque. Tighten the left support cushion bolt/nut to 41 N·m (30 ft. lbs.) torque.

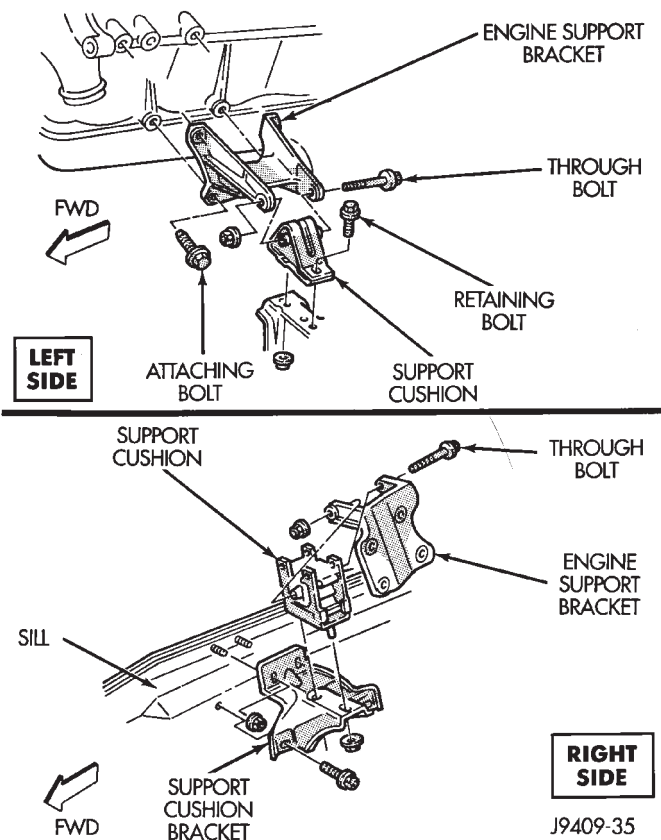

Fig. 6 Front Mounts—XJ Vehicles

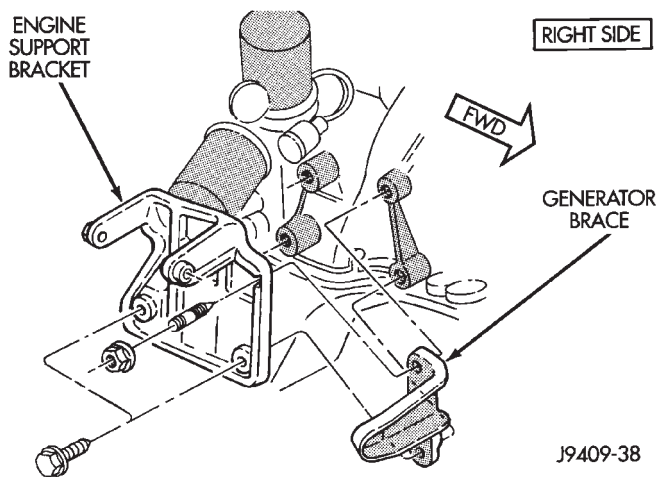

Fig. 7 Engine Support Bracket—Right Side

- (4) Install the through bolt and the retaining nut (Fig. 6). Tighten the through bolt nut to 65 N·m (48 ft. lbs.) torque.
- (5) Remove the engine support.
- (6) Lower the vehicle.
- (7) Connect negative cable to battery.

REMOVAL—YJ VEHICLES

- (1) Disconnect negative cable from battery.
- (2) Raise the vehicle.

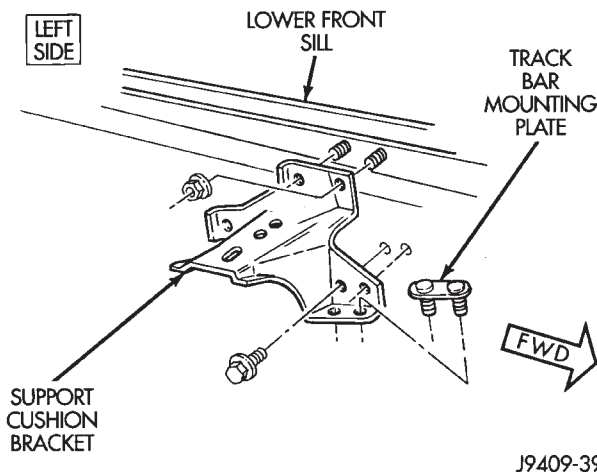

Fig. 8 Support Cushion Bracket—Left Side

- (3) Support the engine.
- (4) Remove through bolt nut (Fig. 9). DO NOT remove the through bolt.
- (5) Remove the retaining bolts/nuts from the support cushions (Fig. 9).
- (6) Remove the through bolt.
- (7) Remove the engine support cushions.

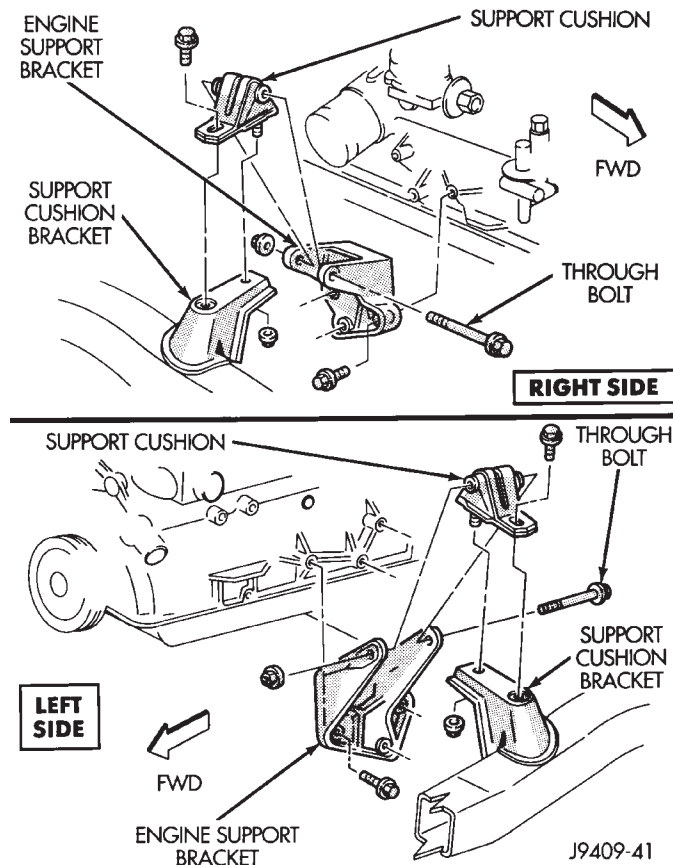

Fig. 9 Front Mounts—YJ Vehicles

INSTALLATION—YJ VEHICLES

(1) If the engine support bracket was removed, position the bracket onto the block and install the attaching bolts (Fig. 9). Tighten the bolts to 62 N·m (46 ft. lbs.) torque.

(2) Place the support cushion on the support cushion bracket (Fig. 9). Install the support cushion retaining bolts and nuts. Tighten the bolts/nuts to 52 N·m (38 ft. lbs.) torque.

(3) Install the through bolt and the retaining nut (Fig. 9). Tighten the through bolt nut to 69 N·m (51 ft. lbs.) torque.

(4) Remove the engine support.

(5) Lower the vehicle.

(6) Connect negative cable to battery.

ENGINE MOUNT—REAR

A resilient rubber cushion supports the transmission at the rear between the transmission extension housing and the rear support crossmember or skid plate.

REMOVAL—XJ VEHICLES

(1) Disconnect negative cable from battery.

(2) Raise the vehicle and support the transmission.

(3) Remove the nuts holding the support cushion to the crossmember (Figs. 10 and 11). Remove the crossmember.

(4) MANUAL TRANSMISSION:

(a) Remove the support cushion nuts and remove the cushion.

(b) If necessary, remove the bolts holding the transmission support bracket to the transmission (Fig. 10). Remove the bracket.

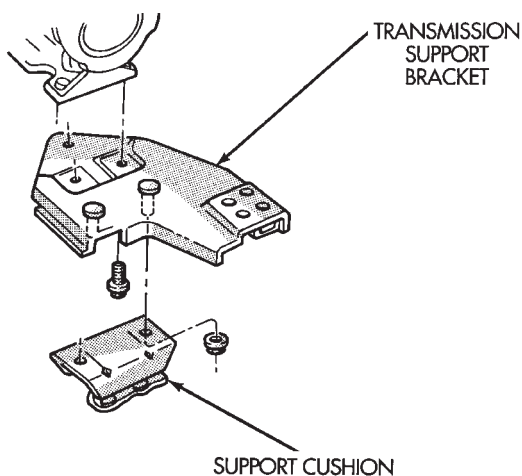

Fig. 10 Rear Mount—XJ Vehicles (Manual Transmission)

(5) AUTOMATIC TRANSMISSION:

(a) Remove the support cushion bolts and remove the cushion and the transmission support bracket.

(b) If necessary on 2WD vehicles, remove the bolts holding the transmission support adaptor bracket to the transmission (Fig. 11). Remove the adaptor bracket.

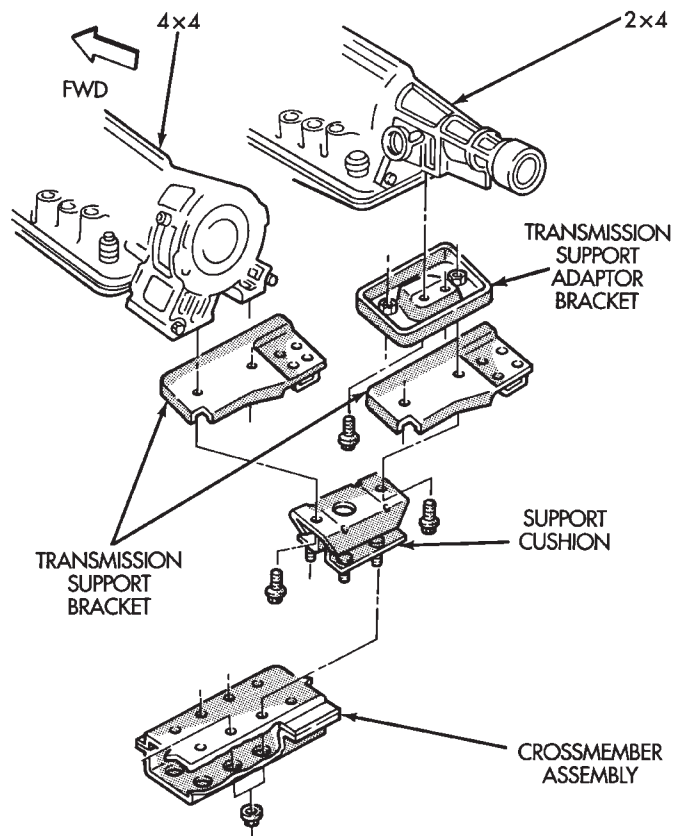

Fig. 11 Rear Mount—XJ Vehicles (Automatic Transmission)

INSTALLATION—XJ VEHICLES**(1) MANUAL TRANSMISSION:**

(a) If removed, position the transmission support bracket to the transmission and install the bolts. Tighten the bolts to 43 N·m (32 ft. lbs.) torque.

(b) Position the support cushion onto the transmission support bracket. Install and tighten the nuts to 46 N·m (34 ft. lbs.) torque.

(2) AUTOMATIC TRANSMISSION:

(a) If removed, position the transmission support adaptor bracket (2WD vehicles) to the transmission and install the bolts. Tighten the bolts to 75 N·m (55 ft. lbs.) torque.

(b) Position the transmission support bracket and support cushion to the transmission and install the bolts. Tighten the bolts to 75 N·m (55 ft. lbs.) torque.

(3) Position the crossmember onto the support cushion studs and install the nuts. Tighten the nuts to 22 N·m (192 in. lbs.) torque.

(4) Install the crossmember to sill bolts and tighten to 41 N·m (30 ft. lbs.) torque.

- (5) Remove the transmission support.
- (6) Lower the vehicle.
- (7) Connect negative cable to battery.

REMOVAL—YJ VEHICLES

- (1) Disconnect negative cable from battery.
- (2) Raise the vehicle and support the transmission.
- (3) Remove the nuts holding the support cushion to the skid plate (Figs. 12 and 13).
- (4) Remove the skid plate bolts and the skid plate.
- (5) **MANUAL TRANSMISSION:**
 - (a) Remove the bolts holding the support cushion and torque arm bracket to the transmission (Fig. 12).
 - (b) Remove the support cushion and torque arm bracket.

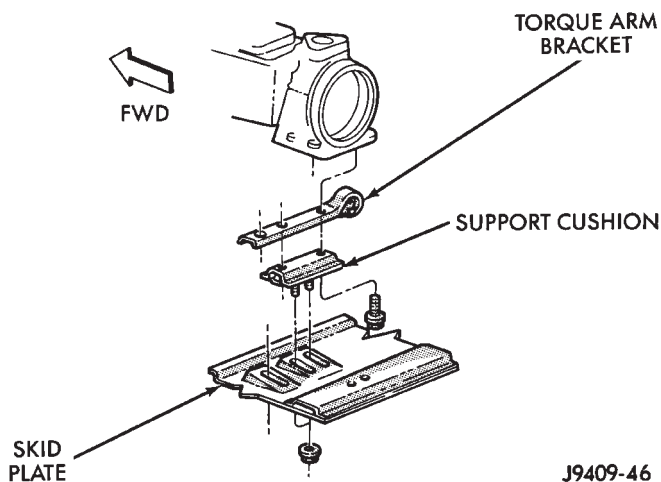

Fig. 12 Rear Mount—YJ Vehicles (Manual Transmission)

- (6) **AUTOMATIC TRANSMISSION:**
 - (a) Remove the bolts and nuts holding the support cushion to the torque arm bracket (Fig. 13). Remove the support cushion.
 - (b) Remove the bolts holding the torque arm bracket to the transmission (Fig. 13). Remove the torque arm bracket.

INSTALLATION—YJ VEHICLES

- (1) **MANUAL TRANSMISSION:**
 - (a) Position the torque arm bracket and support cushion to the transmission and install the bolts (Fig. 12).
 - (b) Tighten the bolts to 54 N·m (40 ft. lbs.) torque.
- (2) **AUTOMATIC TRANSMISSION:**
 - (a) Position the torque arm bracket to the transmission and install the bolts. Tighten the bolts to 54 N·m (40 ft. lbs.) torque.
 - (b) Position the support cushion to the torque arm bracket and install the bolts and nuts. Tighten the nuts to 54 N·m (40 ft. lbs.) torque.

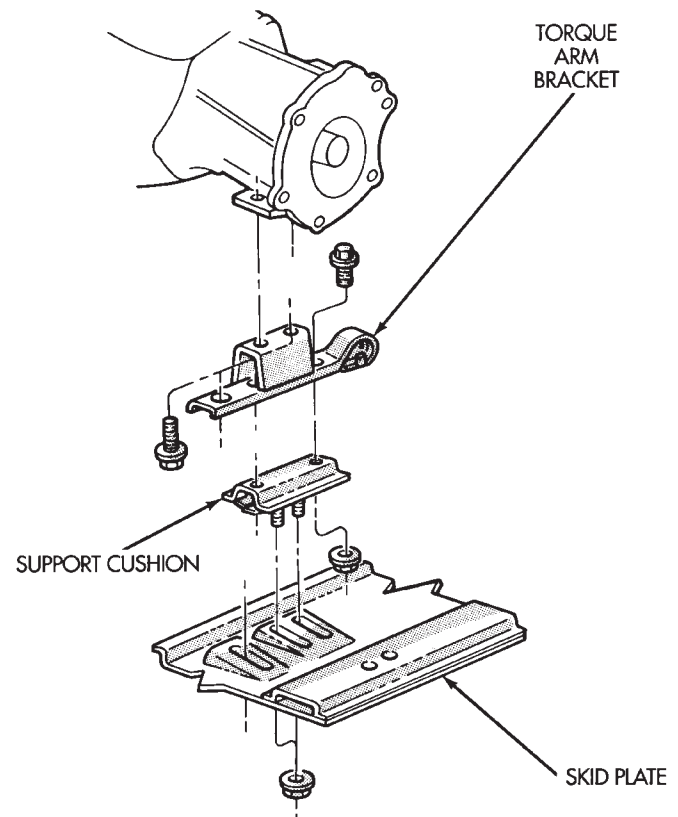

Fig. 13 Rear Mount—YJ Vehicles (Automatic Transmission)

- (3) Position the skid plate to the studs of the support cushion and install the nuts (Figs. 12 and 13). Tighten the stud nuts to 54 N·m (40 ft. lbs.) torque.
- (4) Install the skid plate bolts to the sill and tighten to 88 N·m (65 ft. lbs.) torque.
- (5) Remove the transmission support.
- (6) Lower the vehicle.
- (7) Connect negative cable to battery.

ENGINE DAMPER

REMOVAL

- (1) Disconnect negative cable from battery.
- (2) Remove the top and bottom damper nuts (Fig. 14).
- (3) Remove the outer retainers and bushings (Fig. 14).
- (4) Remove the top damper bracket nut and bolts (Fig. 14).
- (5) Remove the bracket, inner retainers, bushings and the damper (Fig. 14).

INSTALLATION

- (1) Install the damper on the lower bracket with the lower inner retainer and bushing in place.

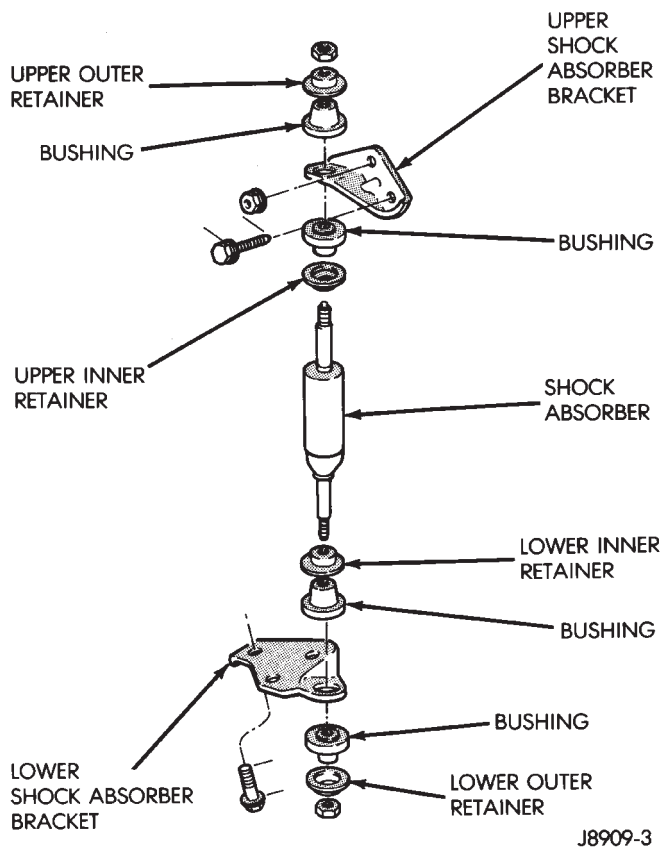

Fig. 14 Engine Damper

- (2) Install the upper inner retainer and bushing on the top of the damper.
- (3) Position the upper damper bracket over the damper and install the stud nut and bolts.
- (4) Tighten the stud nut to 23 N·m (17 ft. lbs.) torque. Tighten the bracket bolts to 61 N·m (45 ft. lbs.) torque.
- (5) Install the bushing, upper outer retainer and damper nut.
- (6) Install the bushing, lower outer retainer and damper nut.
- (7) Tighten the upper and lower damper nuts.
- (8) Connect negative cable to battery.

ENGINE ASSEMBLY—XJ VEHICLES

REMOVAL

- (1) Disconnect the battery cables. Remove the battery.
- (2) Mark the hinge locations on the hood panel for alignment reference during installation. Remove the engine compartment lamp. Remove the hood.

WARNING: THE COOLANT IN A RECENTLY OPERATED ENGINE IS HOT AND PRESSURIZED. USE CARE TO PREVENT SCALDING BY HOT COOLANT. CAREFULLY RELEASE THE PRESSURE BEFORE REMOVING THE RADIATOR DRAIN COCK AND CAP.

(3) Remove the radiator drain cock and radiator cap to drain the coolant. DO NOT waste usable coolant. If the solution is clean, drain the coolant into a clean container for reuse.

- (4) Remove the lower radiator hose.
- (5) Remove the upper radiator hose and coolant recovery hose (Fig. 15).
- (6) Remove the fan shroud (Fig. 15).

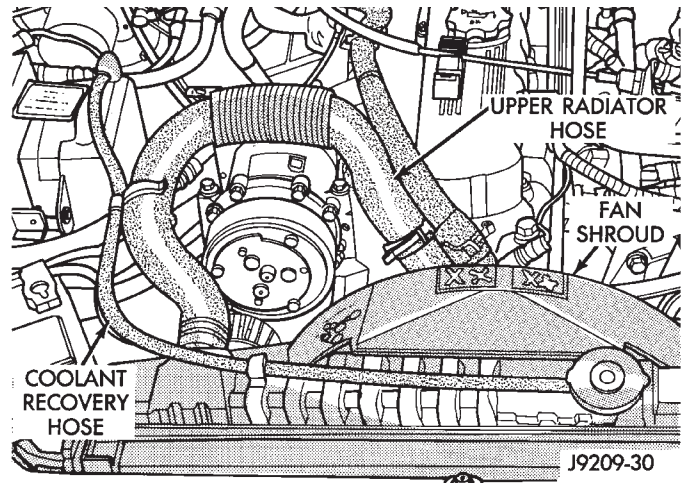

Fig. 15 Upper Radiator Hose, Coolant Recovery Hose & Fan Shroud

- (7) Disconnect the transmission fluid cooler tubing (automatic transmission).
- (8) Remove the radiator/condenser (if equipped with air conditioning).
- (9) Remove fan assembly and install a 5/16 x 1/2-inch SAE capscrew through fan pulley into water pump flange. This will maintain the pulley and water pump in alignment when crankshaft is rotated.
- (10) Disconnect the heater hoses (Figs. 16 and 17).
- (11) Disconnect the throttle linkages (Fig. 16), speed control cable (if equipped) and throttle valve rod.
- (12) Disconnect the oxygen sensor wire connector.
- (13) Disconnect the wires from the starter motor solenoid.
- (14) Disconnect all fuel injection harness connections.
- (15) Disconnect the quick-connect fuel lines at the fuel rail and return line by squeezing the two retaining tabs against the fuel tube (Fig. 16). Pull the fuel tube and retainer from the quick-connect fitting (refer to Group 14, Fuel System for the proper procedure).
- (16) Remove the fuel line bracket from the intake manifold.
- (17) Remove the air cleaner assembly (Fig. 18).
- (18) If equipped with air conditioning, remove the service valves and cap the compressor ports.
- (19) Remove the power brake vacuum check valve from the booster, if equipped.
- (20) If equipped with power steering (Fig. 18):

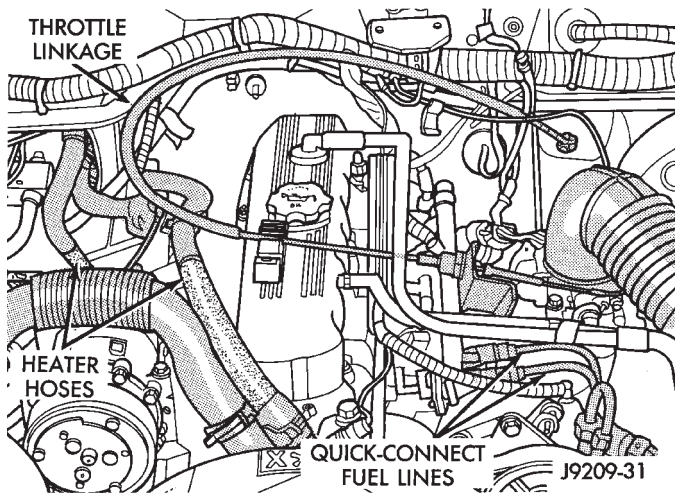

Fig. 16 Heater Hoses (LH Drive Vehicles), Throttle Linkage & Quick-Connect Fuel Lines

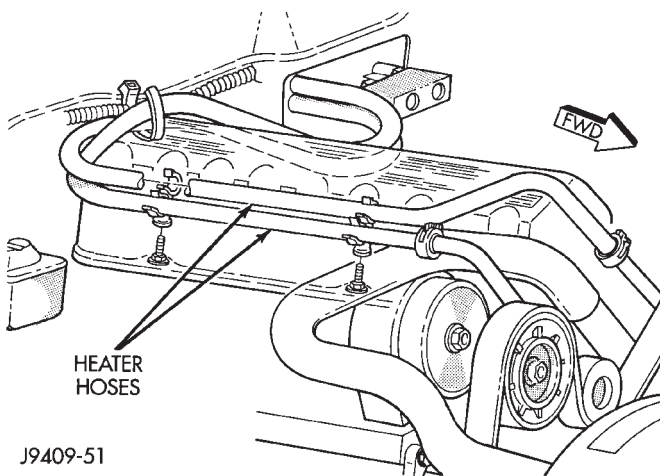

Fig. 17 Heater Hoses (RH Drive Vehicle)

- (a) Disconnect the power steering hoses from the fittings at the steering gear.
- (b) Drain the pump reservoir.
- (c) Cap the fittings on the hoses and steering gear to prevent foreign material from entering the system.
- (21) Disconnect the coolant hoses from the rear of the intake manifold.
- (22) Identify, tag and disconnect all necessary wire connectors and vacuum hoses.
- (23) Raise the vehicle.
- (24) Remove the oil filter.
- (25) Remove the starter motor.
- (26) Disconnect the exhaust pipe from the exhaust manifold.
- (27) Remove the flywheel/converter housing access cover.
- (28) If equipped with an automatic transmission, mark the converter and drive plate location in reference to each other and remove the converter-to-drive plate bolts.

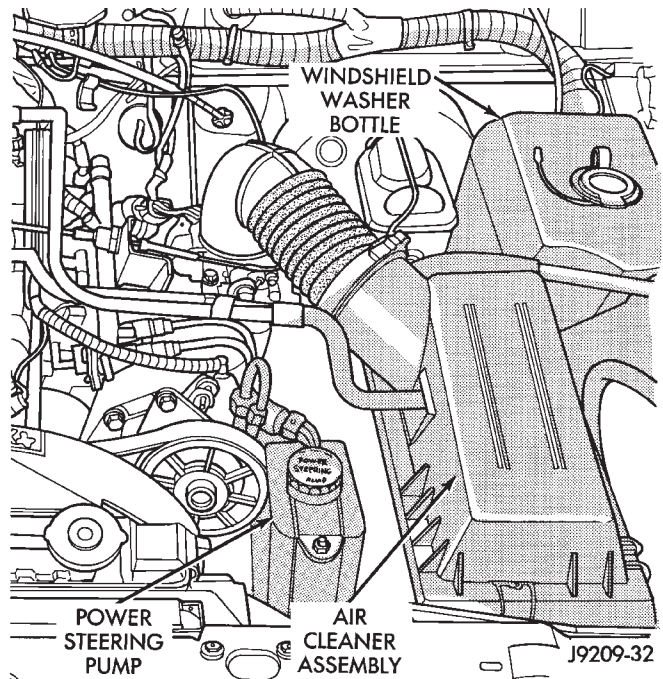

Fig. 18 Air Cleaner and Power Steering Pump

- (29) Remove the upper flywheel/converter housing bolts and loosen the bottom bolts.
- (30) Remove the engine support cushion-to-engine compartment bracket bolts.
- (31) Remove the engine shock damper bracket from the sill.
- (32) Lower the vehicle.
- (33) Attach a lifting device to the engine.
- (34) Raise the engine slightly off the front supports.
- (35) Place a support stand under the converter or flywheel housing.
- (36) Remove the remaining bottom converter or flywheel housing bolts.
- (37) Lift the engine out of the engine compartment and install on an engine stand.
- (38) Install the oil filter to keep foreign material out of the engine.

INSTALLATION

- (1) Remove the oil filter.
- (2) Lift the engine off the stand and lower it into the engine compartment. For easier installation, it may be useful to remove the engine support cushions from the engine support brackets as an aide for alignment of the engine-to-transmission.
- (3) If equipped with a manual transmission:
 - (a) Insert the transmission shaft into the clutch spline.
 - (b) Align the flywheel housing with the engine.
 - (c) Install and tighten the flywheel housing lower bolts finger tight.
- (4) If equipped with an automatic transmission:

- (a) Align the transmission torque converter housing with the engine.
- (b) Loosely install the converter housing lower bolts and install the next higher bolt and nut on each side.
- (c) Tighten all 4 bolts finger-tight.
- (5) Install the engine support cushions (if removed).
- (6) Lower the engine and engine support cushions onto the engine compartment brackets.
- (7) Remove the engine lifting device.
- (8) Raise the vehicle.
- (9) If equipped with an automatic transmission:
 - (a) Install the converter-to-drive plate bolts. Ensure the installation reference marks are aligned. Tighten the bolts to 54 N·m (40 ft. lbs.) torque.
 - (b) Install the converter-housing access cover.
 - (c) Install the exhaust pipe support.
- (10) Install the remaining converter or flywheel housing bolts.
- (11) Install the starter motor and connect the cable. Tighten the bolts to 45 N·m (33 ft. lbs.) torque.
- (12) Tighten the engine support cushioning through-bolt nuts.
- (13) Install the remaining flywheel/converter housing bolts. Tighten the bolts to 38 N·m (28 ft. lbs.) torque.
- (14) Connect the exhaust pipe to the manifold.
- (15) Install the oil filter.
- (16) Lower the vehicle.
- (17) Connect the coolant hoses and tighten the clamps.
- (18) If equipped with power steering:
 - (a) Remove the protective caps
 - (b) Connect the hoses to the fittings at the steering gear. Tighten the nut to 52 N·m (38 ft. lbs.) torque.
 - (c) Fill the pump reservoir with fluid.
- (19) Remove the pulley-to-water pump flange alignment capscrew and install the fan and spacer or Tempatrol fan assembly.
- (20) Install the fan shroud and radiator/condenser (if equipped with air conditioning).
- (21) Connect the radiator hoses.
- (22) Connect the automatic transmission fluid cooler pipes, if equipped.
- (23) Connect the oxygen sensor wire connector.
- (24) Connect the throttle valve rod and retainer. Connect the throttle cable and install the rod. Install the throttle valve rod spring.
- (25) Connect the speed control cable, if equipped.
- (26) Connect the fuel supply and return lines to the throttle body.
- (27) Connect all the vacuum hoses and wire connectors.
- (28) Connect the service valves to the A/C compressor ports, if equipped with air conditioning.

- (29) Fill the power steering reservoir.
- (30) Connect the battery cables.
- (31) Install the hood.
- (32) Install the air cleaner.
- (33) Start the engine and inspect for leaks.
- (34) Fill the cooling system.
- (35) Stop the engine and check the fluid levels. Add fluid, as required.

ENGINE ASSEMBLY—YJ VEHICLES

REMOVAL

- (1) Place a protective cloth over the windshield frame. Raise the hood and rest it on the windshield frame (Fig. 19).

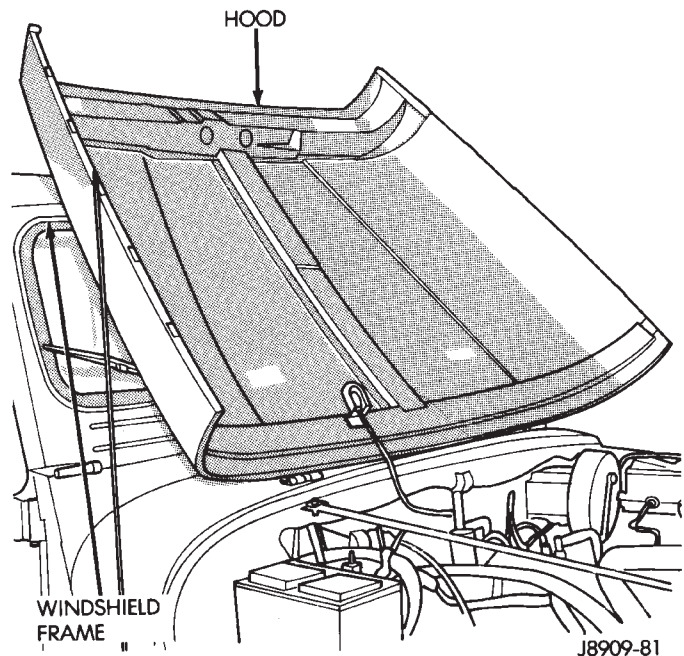

Fig. 19 Hood on Windshield Frame

- (2) Disconnect the battery cable clamps and remove the battery.

WARNING: THE COOLANT IN A RECENTLY OPERATED ENGINE IS HOT AND PRESSURIZED. USE CARE TO PREVENT SCALDING BY HOT COOLANT. CAREFULLY RELEASE THE PRESSURE BEFORE REMOVING THE RADIATOR DRAIN COCK AND CAP.

- (3) Remove the radiator drain cock and radiator cap to drain the coolant. DO NOT waste usable coolant. If the solution is clean, drain the coolant into a clean container for reuse.
- (4) Disconnect the wire connectors from the generator.
- (5) Disconnect the ignition coil and distributor wire connectors.
- (6) Disconnect the oil pressure sender wire connector.

(7) Disconnect the wires at the starter motor solenoid and injection wire harness connector.

(8) Disconnect the quick-connect fuel lines at the fuel rail and return line by squeezing the two retaining tabs against the fuel tube (Fig. 20). Pull the fuel tube and retainer from the quick-connect fitting (refer to Group 14, Fuel System for the proper procedure).

(9) Remove the fuel line bracket from the intake manifold.

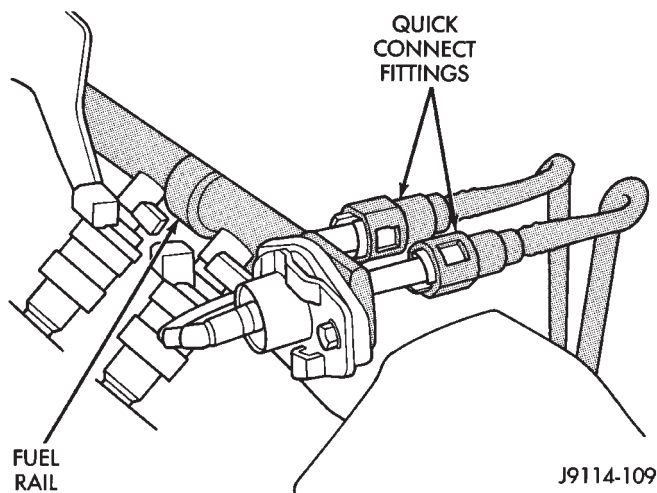

Fig. 20 Fuel Line Quick-Connect Couplings

- (10) Disconnect the engine ground strap.
- (11) Remove the air cleaner assembly.
- (12) Disconnect the vacuum purge hose at the fuel vapor canister tee.
- (13) Disconnect the idle speed actuator wire connector.
- (14) Disconnect the throttle cable and remove it from the bracket.
- (15) Disconnect the throttle rod at the bellcrank.
- (16) Disconnect the speed control cable, if equipped.
- (17) Disconnect the oxygen sensor wire connector.
- (18) Disconnect the upper and lower radiator hoses at the radiator.
- (19) Disconnect the coolant hoses from the rear of the intake manifold and thermostat housing.
- (20) Disconnect the heater hoses.
- (21) Remove the fan shroud screws.
- (22) Remove the radiator attaching bolts.
- (23) Remove the radiator and fan shroud.
- (24) Remove the fan and spacer or Tempatrol fan assembly.
- (25) Install a 5/16 X 1/2-inch SAE capscrew through fan pulley into water pump flange. This will maintain the pulley and water pump in alignment when crankshaft is rotated.
- (26) Remove the power brake vacuum check valve from the booster, if equipped.
- (27) If equipped with power steering:

(a) Disconnect the hoses from the fittings at the steering gear.

(b) Drain the pump reservoir.

(c) Cap the fittings on the hoses and steering gear to prevent foreign objects from entering the system.

(28) Lift the vehicle and support it with support stands.

(29) Remove the oil filter.

(30) Remove the starter motor.

(31) Remove the flywheel housing access cover.

(32) Remove the engine support cushion-to-bracket through bolts.

(33) Disconnect the exhaust pipe from the manifold.

(34) Remove the upper flywheel housing bolts and loosen the bottom bolts.

(35) Remove the engine shock damper bracket from the sill.

(36) Lower the vehicle.

(37) Attach a lifting device to the engine.

(38) Raise the engine off the front supports.

(39) Place a support stand under the flywheel housing.

(40) Remove the remaining flywheel housing bolts.

(41) Lift the engine out of the engine compartment and install on an engine stand.

(42) Install the oil filter to keep foreign material out of the engine.

INSTALLATION

(1) Remove the oil filter.

(2) Lift the engine off the stand and lower it into the engine compartment. For easier installation, it may be useful to remove the engine support cushions from the engine support brackets as an aide for alignment of the engine-to-transmission.

(3) Insert the transmission shaft into the clutch spline.

(4) Align the flywheel housing with the engine.

(5) Install and finger tighten the flywheel housing lower bolts.

(6) Install the engine support cushions (if removed).

(7) Remove the support stand from beneath the flywheel housing.

(8) Lower the engine and engine support cushions onto the engine compartment brackets. Ensure that the bolt holes are aligned. Install the bolts and tighten.

(9) Remove the engine lifting device.

(10) Raise the vehicle.

(11) Attach the engine shock damper bracket to the sill.

(12) Attach the exhaust pipe to the manifold. Install and tighten the nuts to 31 N·m (23 ft. lbs.) torque.

(13) Install the flywheel housing access cover.

- (14) Install the remaining flywheel housing bolts. Tighten the bolts to 38 N·m (28 ft. lbs.) torque.
- (15) Install the starter motor and connect the cable. Tighten the bolts to 45 N·m (33 ft. lbs.) torque.
- (16) Install the oil filter.
- (17) Lower the vehicle.
- (18) Connect the coolant hoses and tighten the clamps.
- (19) If equipped with power steering:
 - (a) Remove the protective caps
 - (b) Connect the hoses to the fittings at the steering gear. Tighten the nut to 52 N·m (38 ft. lbs.) torque.
 - (c) Fill the pump reservoir with fluid.
- (20) Remove the pulley-to-water pump flange alignment capscrew and install the fan and spacer or Tempatrol fan assembly.
- (21) Tighten the serpentine drive belt according to the specifications listed in Group 7, Cooling System.
- (22) Install the fan shroud and radiator.
- (23) Connect the radiator hoses.
- (24) Connect the heater hoses.
- (25) Connect the throttle valve rod and retainer.
- (26) Connect the throttle cable and install the rod.
- (27) Install the throttle valve rod spring.
- (28) Connect the speed control cable, if equipped.
- (29) Connect the oxygen sensor wire connector.
- (30) Install the vacuum hose and check valve on the brake booster.
- (31) Connect the coolant temperature sensor wire connector.
- (32) Connect the idle speed actuator wire connector.
- (33) Connect the fuel inlet and return hoses at the fuel rail. Verify that the quick-connect fitting assembly fits securely over the fuel lines by giving the fuel lines a firm tug.
- (34) Install the fuel line bracket to the intake manifold.
- (35) Connect all fuel injection wire connections.
- (36) Install the engine ground strap.
- (37) Connect the ignition coil wire connector.
- (38) Remove the coolant temperature sending unit to permit air to escape from the block. Fill the cooling system with coolant. Install the coolant temperature sending unit when the system is filled.
- (39) Install the battery and connect the battery cables.
- (40) Install the air cleaner bonnet to the throttle body.
- (41) Install the air cleaner.
- (42) Lower the hood and secure in place.
- (43) Start the engine and inspect for leaks.
- (44) Stop the engine and check the fluid levels. Add fluid, as required.

ENGINE CYLINDER HEAD COVER

A cured gasket is part of the engine cylinder head cover.

REMOVAL

- (1) Disconnect negative cable from battery.
- (2) Disconnect the Crankcase Ventilation (CCV) vacuum hose from engine cylinder head cover (Fig. 1).
- (3) Disconnect the fresh air inlet hose from the engine cylinder head cover (Fig. 1).
- (4) Remove the engine cylinder head cover mounting bolts.
- (5) Remove the engine cylinder head cover.

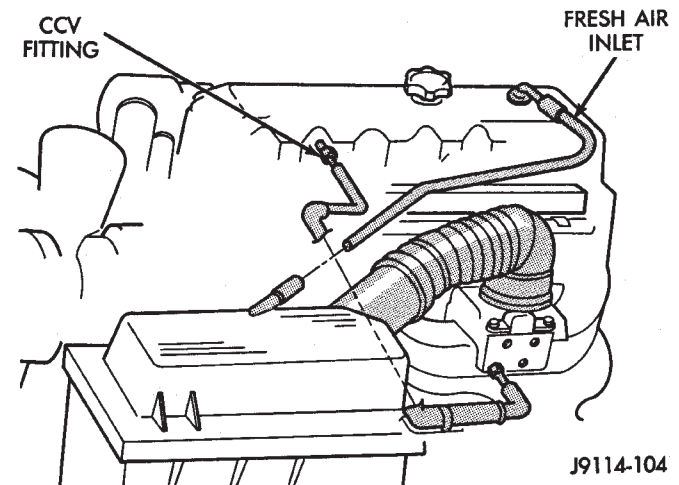

Fig. 1 Engine Cylinder Head Cover

CLEANING

Remove any original sealer from the cover sealing surface of the engine cylinder head and clean the surface using a fabric cleaner.

Remove all residue from the sealing surface using a clean, dry cloth.

INSPECTION

Inspect the engine cylinder head cover for cracks. Replace the cover, if cracked.

The original grey gasket material should NOT be removed. If sections of the gasket material are missing or are compressed, replace the engine cylinder head cover. However, sections with minor damage such as small cracks, cuts or chips may be repaired with a hand held applicator. The new material must be smoothed over to maintain gasket height. Allow the gasket material to cure prior to engine cylinder head cover installation.

INSTALLATION

(1) If a replacement cover is installed, transfer the CCV valve grommet the oil filler cap from the original cover to the replacement cover.

(2) Install engine cylinder head cover. Tighten the mounting bolts to 10 N·m (85 in. lbs.) torque.

- (3) Connect the CCV hoses (Fig. 1).
- (4) Connect negative cable to battery.

ROCKER ARMS

This procedure can be done with the engine in or out of the vehicle.

REMOVAL

- (1) Remove the engine cylinder head cover.
- (2) Remove the capscrews at each bridge and pivot assembly (Fig. 2). Alternately loosen the capscrews one turn at a time to avoid damaging the bridges.
- (3) Check for rocker arm bridges which are causing misalignment of the rocker arm to valve tip area.
- (4) Remove the bridges, pivots and corresponding pairs of rocker arms (Fig. 2). Place them on a bench in the same order as removed.
- (5) Remove the push rods and place them on a bench in the same order as removed.

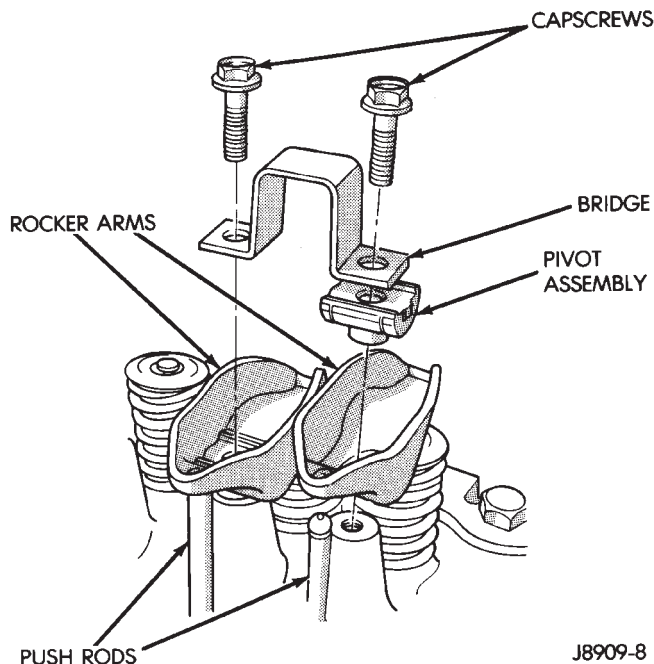

Fig. 2 Rocker Arm Assembly

CLEANING

Clean all the components with cleaning solvent. Use compressed air to blow out the oil passages in the rocker arms and push rods.

INSPECTION

Inspect the pivot surface area of each rocker arm. Replace any that are scuffed, pitted, cracked or excessively worn.

Inspect the valve stem tip contact surface of each rocker arm and replace any rocker arm that is deeply pitted.

Inspect each push rod end for excessive wear and replace as required. If any push rod is excessively

worn because of lack of oil, replace it and inspect the corresponding hydraulic tappet for excessive wear.

Inspect the push rods for straightness by rolling them on a flat surface or by shining a light between the push rod and the flat surface.

A wear pattern along the length of the push rod is not normal. Inspect the engine cylinder head for obstruction if this condition exists.

INSTALLATION

(1) Lubricate the ball ends of the push rods with Mopar Engine Oil Supplement, or equivalent and install push rods in their original locations. Ensure that the bottom end of each push rod is centered in the tappet plunger cap seat.

(2) Using Mopar Engine Oil Supplement, or equivalent, lubricate the area of the rocker arm that the pivot contacts. Install rocker arms, pivots and bridge above each cylinder in their originally position.

(3) Loosely install the capscrews through each bridge.

(4) At each bridge, tighten the capscrews alternately, one turn at a time, to avoid damaging the bridge. Tighten the capscrews to 28 N·m (21 ft. lbs.) torque.

(5) Install the engine cylinder head cover.

ENGINE CYLINDER HEAD

This procedure can be done with the engine in or out of the vehicle.

REMOVAL

- (1) Disconnect negative cable from battery.

WARNING: DO NOT REMOVE THE CYLINDER BLOCK DRAIN PLUGS OR LOOSEN THE RADIATOR DRAIN COCK WITH THE SYSTEM HOT AND PRESSURIZED BECAUSE SERIOUS BURNS FROM THE COOLANT CAN OCCUR.

(2) Drain the coolant and disconnect the hoses at the engine thermostat housing. **DO NOT** waste reusable coolant. If the solution is clean and is being drained only to service the engine or cooling system, drain the coolant into a clean container for reuse.

(3) Remove the air cleaner assembly.

(4) Remove the engine cylinder head cover.

(5) Remove the capscrews, bridge and pivot assemblies and rocker arms (Fig. 2).

(6) Remove the push rods (Fig. 2). **Retain the push rods, bridges, pivots and rocker arms in the same order as removed.**

(7) Loosen the serpentine drive belt at the power steering pump, if equipped or at the idler pulley (refer to Group 7, Cooling System for the proper procedure).

(8) If equipped with air conditioning, perform the following:

- (a) Remove the bolts from the A/C compressor mounting bracket and set the compressor aside.
- (b) Remove the air conditioner compressor bracket bolts from the engine cylinder head.
- (c) Loosen the through bolt at the bottom of the bracket.
- (9) If equipped, disconnect the power steering pump bracket. Set the pump and bracket aside. DO NOT disconnect the hoses.
- (10) Remove the fuel lines and vacuum advance hose.
- (11) Remove the intake and engine exhaust manifolds from the engine cylinder head (refer to Group 11, Exhaust System and Intake Manifold for the proper procedures).
- (12) Disconnect the ignition wires and remove the spark plugs.
- (13) Disconnect the temperature sending unit wire connector.
- (14) Remove the ignition coil and bracket assembly.
- (15) Remove the engine cylinder head bolts.
- (16) Remove the engine cylinder head and gasket (Fig. 3).
- (17) If this was the first time the bolts were removed, put a paint dab on the top of the bolt. If the bolts have a paint dab on the top of the bolt or it isn't known if they were used before, discard the bolts.
- (18) Stuff clean lint free shop towels into the cylinder bores.

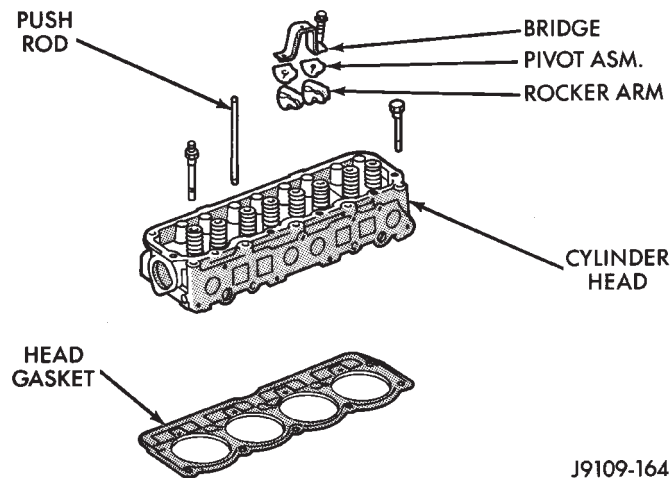

Fig. 3 Engine Cylinder Head Assembly

CLEANING

- Thoroughly clean the engine cylinder head and cylinder block mating surfaces. Clean the intake and exhaust manifold and engine cylinder head mating surfaces. Remove all gasket material and carbon.
- Check to ensure that no coolant or foreign material has fallen into the tappet bore area.
- Remove the carbon deposits from the combustion chambers and top of the pistons.

INSPECTION

Use a straightedge and feeler gauge to check the flatness of the engine cylinder head and block mating surfaces.

INSTALLATION

The engine cylinder head gasket is a composition gasket. The gasket is to be installed DRY. **DO NOT use a gasket sealing compound on the gasket.**

If the engine cylinder head is to be replaced and the original valves used, measure the valve stem diameter. Only standard size valves can be used with a service replacement engine cylinder head unless the replacement head valve stem guide bores are reamed to accommodate oversize valve stems. Remove all carbon buildup and reface the valves.

- (1) Fabricate two engine cylinder head alignment dowels from used head bolts (Fig. 4). Use the longest head bolt. Cut the head of the bolt off below the hex head. Then cut a slot in the top of the dowel to allow easier removal with a screwdriver.

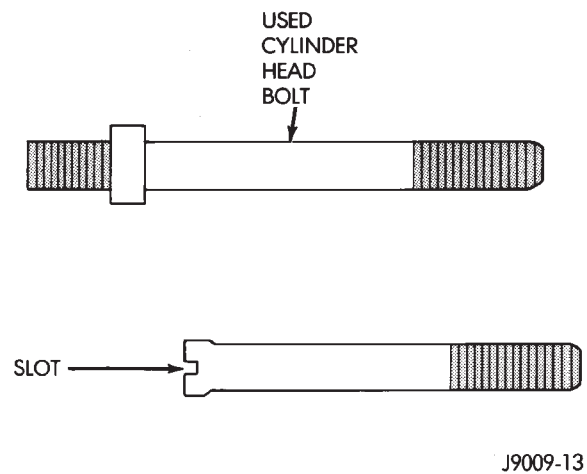

Fig. 4 Fabricate Alignment Dowels

- (2) Install one dowel in bolt hole No.10 and the other dowel in bolt hole No.8 (Fig. 5).

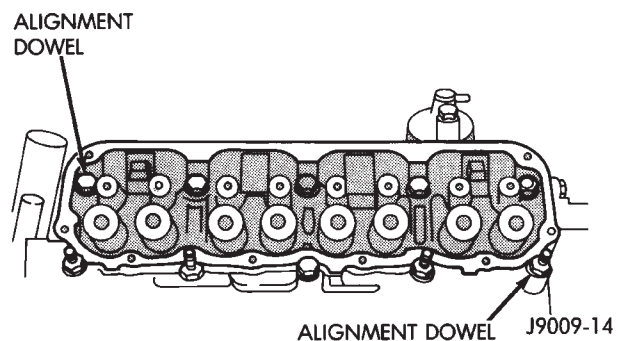

Fig. 5 Alignment Dowel Locations

- (3) Remove the shop towels from the cylinder bores. Coat the bores with clean engine oil.
- (4) Place the engine cylinder head gasket (with the numbers facing up) over the dowels.

(5) Place the engine cylinder head over the dowels.

CAUTION: Engine cylinder head bolts should be re-used only once. Replace the head bolts if they were used before or if they have a paint dab on the top of the bolt.

(6) Coat the threads of bolt No.7, only, with Loctite PST sealant or equivalent.

(7) Install all head bolts, except No.8 and No.10.

(8) Remove the dowels.

(9) Install No.8 and No.10 head bolts.

(10) Tighten the engine cylinder head bolts in sequence according to the following procedure (Fig. 6):

(a) Tighten all bolts in sequence (1 through 10) to 30 N·m (22 ft. lbs.) torque.

(b) Tighten all bolts in sequence (1 through 10) to 61 N·m (45 ft. lbs.) torque.

(c) Check all bolts to verify they are set to 61 N·m (45 ft. lbs.) torque.

(d) Tighten bolts (in sequence):

- Bolts 1 through 6 to 149 N·m (110 ft. lbs.) torque.
- Bolt 7 to 136 N·m (100 ft. lbs.) torque.
- Bolts 8 through 10 to 149 N·m (110 ft. lbs.) torque.

CAUTION: During the final tightening sequence, bolt No.7 will be tightened to a lower torque than the rest of the bolts. DO NOT overtighten bolt No.7.

(e) Check all bolts in sequence to verify the correct torque.

(f) If not already done, clean and mark each bolt with a dab of paint after tightening. Should you encounter bolts which were painted in an earlier service operation, replace them.

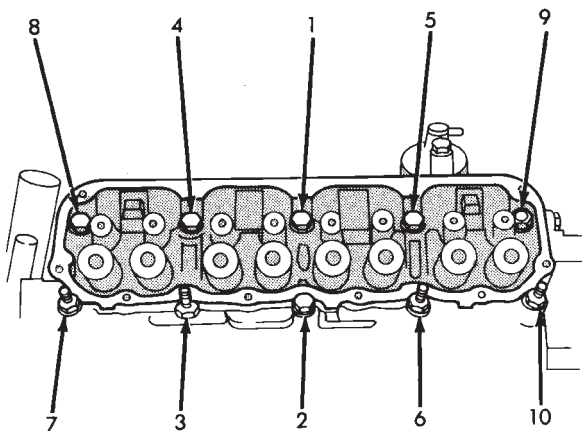

J9009-15

Fig. 6 Engine cylinder head Bolt Tightening Sequence

(11) Install the ignition coil and bracket assembly.

(12) Connect the temperature sending unit wire connector.

(13) Install the spark plugs and tighten to 37 N·m (27 ft. lbs.) torque. Connect the ignition wires.

(14) Install the intake and exhaust manifolds (refer to Group 11, Exhaust System and Intake Manifold for the proper procedures).

(15) Install the fuel lines and the vacuum advance hose.

(16) If equipped, attach the power steering pump and bracket.

(17) Install the push rods, rocker arms, pivots and bridges in the order they were removed.

(18) Install the engine cylinder head cover.

(19) Attach the air conditioning compressor mounting bracket to the engine cylinder head and block. Tighten the bolts to 40 N·m (30 ft. lbs.) torque.

(20) Attach the air conditioning compressor to the bracket. Tighten the bolts to 27 N·m (20 ft. lbs.) torque.

CAUTION: The serpentine drive belt must be routed correctly. Incorrect routing can cause the water pump to turn in the opposite direction causing the engine to overheat.

(21) Install the serpentine drive belt and correctly tension the belt (refer to Group 7, Cooling System for the proper procedure).

(22) Install the air cleaner and ducting.

(23) Install the engine cylinder head cover.

(24) Connect the hoses to the thermostat housing and fill the cooling system to the specified level (refer to Group 7, Cooling Systems for the proper procedure).

(25) The automatic transmission throttle linkage and cable must be adjusted after completing the engine cylinder head installation (refer to Group 21, Transmissions for the proper procedures).

(26) Install the temperature sending unit and connect the wire connector.

(27) Connect the fuel pipe and vacuum advance hose.

(28) Connect negative cable to battery.

(29) Connect the upper radiator hose and heater hose at the thermostat housing.

(30) Fill the cooling system. Check for leaks.

WARNING: USE EXTREME CAUTION WHEN THE ENGINE IS OPERATING. DO NOT STAND IN DIRECT LINE WITH THE FAN. DO NOT PUT HANDS NEAR THE PULLEYS, BELTS OR FAN. DO NOT WEAR LOOSE CLOTHING.

(31) Operate the engine with the radiator cap off. Inspect for leaks and continue operating the engine until the thermostat opens. Add coolant, if required.

VALVE SPRINGS AND OIL SEALS

This procedure can be done with the engine cylinder head installed on the block.

REMOVAL

Each valve spring is held in place by a retainer and a set of conical valve locks. The locks can be removed only by compressing the valve spring.

- (1) Remove the engine cylinder head cover.
- (2) Remove capscrews, bridge and pivot assemblies and rocker arms for access to each valve spring to be removed.
- (3) Remove push rods. Retain the push rods, bridges, pivots and rocker arms in the same order and position as removed.
- (4) Inspect the springs and retainer for cracks and possible signs of weakening.
- (5) Remove the spark plug(s) adjacent to the cylinder(s) below the valve springs to be removed.
- (6) Install a 14 mm (1/2 inch) (thread size) air hose adaptor in the spark plug hole.
- (7) Connect an air hose to the adapter and apply air pressure slowly. Maintain at least 621 kPa (90 psi) of air pressure in the cylinder to hold the valves against their seats. For vehicles equipped with an air conditioner, use a flexible air adaptor when servicing the No.1 cylinder.
- (8) Tap the retainer or tip with a rawhide hammer to loosen the lock from the retainer. Use Valve Spring Compressor Tool MD-998772A to compress the spring and remove the locks (Fig. 7).
- (9) Remove valve spring and retainer (Fig. 7).
- (10) Remove valve stem oil seals (Fig. 7). Note the valve seals are different for intake and exhaust valves. The top of each seal is marked either INT (Intake) or EXH (Exhaust). DO NOT mix the seals.

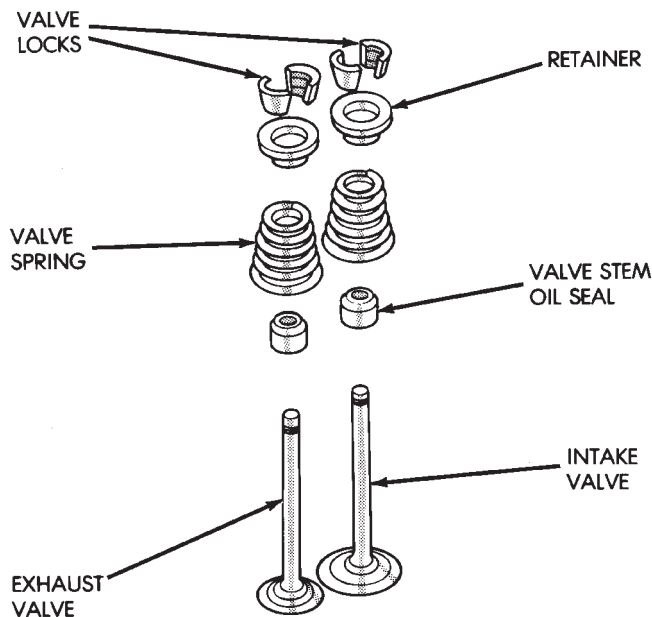

J8909-88

Fig. 7 Valve and Valve Components

INSPECTION

Inspect the valve stems, especially the grooves. An Arkansas smooth stone should be used to remove nicks and high spots.

INSTALLATION

CAUTION: Install oil seals carefully to prevent damage from the sharp edges of the valve spring lock groove.

- (1) Lightly push the valve seal over the valve stem and valve guide boss. Be sure the seal is completely seated on the valve guide boss.
- (2) Install valve spring and retainer.
- (3) Compress the valve spring with Valve Spring Compressor Tool MD-998772A and insert the valve locks. Release the spring tension and remove the tool. Tap the spring from side-to-side to ensure that the spring is seated properly on the engine cylinder head.
- (4) Disconnect the air hose. Remove the adaptor from the spark plug hole and install the spark plug.
- (5) Repeat the procedures for each remaining valve spring to be removed.
- (6) Install the push rods. Ensure the bottom end of each rod is centered in the plunger cap seat of the hydraulic valve tappet.
- (7) Install the rocker arms, pivots and bridge at their original location.
- (8) Tighten the bridge capscrews alternately, one at a time, to avoid damaging the bridge. Tighten the capscrews to 28 N·m (21 ft. lbs.) torque.
- (9) Install the engine cylinder head cover.

VALVES AND VALVE SPRINGS

This procedure is done with the engine cylinder head removed from the block.

REMOVAL

- (1) Remove the engine cylinder head from the cylinder block.
- (2) Use Valve Spring Compressor Tool MD-998772A and compress each valve spring.
- (3) Remove the valve locks, retainers, springs and valve stem oil seals. Discard the oil seals.
- (4) Use an Arkansas smooth stone or a jewelers file to remove any burrs on the top of the valve stem, especially around the groove for the locks.
- (5) Remove the valves, and place them in a rack in the same order as removed.

VALVE CLEANING

Clean all carbon deposits from the combustion chambers, valve ports, valve stems, valve stem guides and head.

Clean all grime and gasket material from the engine cylinder head machined gasket surface.

INSPECTION

Inspect for cracks in the combustion chambers and valve ports.

Inspect for cracks on the exhaust seat.

Inspect for cracks in the gasket surface at each coolant passage.

Inspect valves for burned, cracked or warped heads.

Inspect for scuffed or bent valve stems.

Replace valves displaying any damage.

VALVE REFACING

(1) Use a valve refacing machine to reface the intake and exhaust valves to the specified angle.

(2) After refacing, a margin of at least 0.787 mm (0.031 inch) must remain (Fig. 8). If the margin is less than 0.787 mm (0.031 inch), the valve must be replaced.

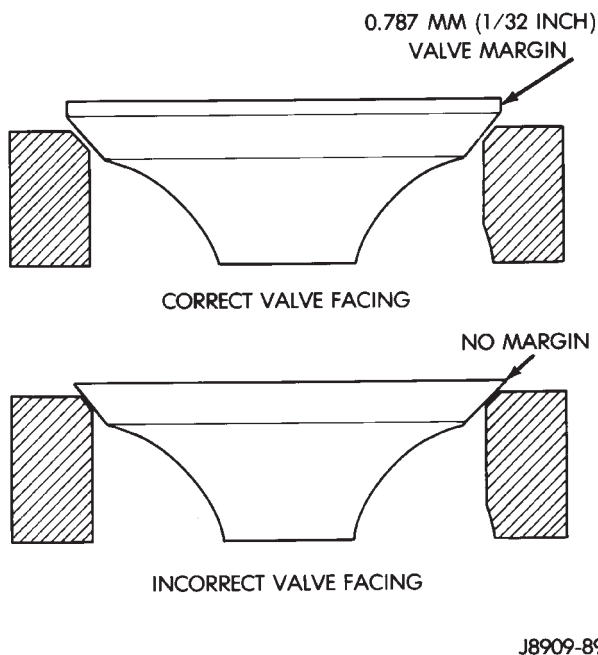

Fig. 8 Valve Facing Margin

VALVE SEAT REFACING

(1) Install a pilot of the correct size in the valve guide bore. Reface the valve seat to the specified angle with a good dressing stone. Remove only enough metal to provide a smooth finish.

(2) Use tapered stones to obtain the specified seat width when required.

(3) Control valve seat runout to a maximum of 0.0635 mm (0.0025 in.)—(Fig. 9).

VALVE STEM OIL SEAL REPLACEMENT

Valve stem oil seals are installed on each valve stem to prevent rocker arm lubricating oil from entering the combustion chamber through the valve guide bores. One seal is marked INT (intake valve) and the other is marked EXH (exhaust valve).

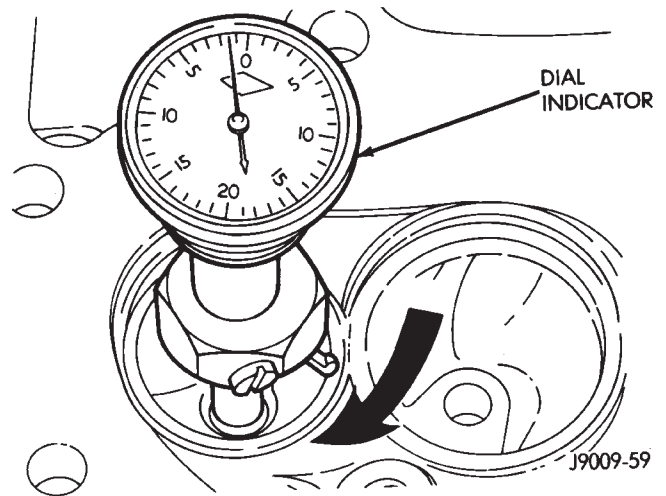

Fig. 9 Measurement of Valve Seat Runout

Replace the oil seals whenever valve service is performed or if the seals have deteriorated.

VALVE GUIDES

The valve guides are an integral part of the engine cylinder head and are not replaceable.

When the valve stem guide clearance is excessive, the valve guide bores must be reamed oversize. Service valves with oversize stems are available in 0.076 mm (0.003 inch) and 0.381 mm (0.015 inch) increments.

Corresponding oversize valve stem seals are also available and must be used with valves having 0.381 mm (0.015 inch) oversize stems.

If the valve guides are reamed oversize, the valve seats must be ground to ensure that the valve seat is concentric to the valve guide.

VALVE STEM-TO-GUIDE CLEARANCE MEASUREMENT

Valve stem-to-guide clearance may be measured by either of the following two methods.

PREFERRED METHOD:

- (1) Remove the valve from the head.
- (2) Clean the valve stem guide bore with solvent and a bristle brush.
- (3) Insert a telescoping gauge into the valve stem guide bore approximately 9.525 mm (.375 inch) from the valve spring side of the head (Fig. 10).
- (4) Remove and measure telescoping gauge with a micrometer.

(5) Repeat the measurement with contacts lengthwise to engine cylinder head.

(6) Compare the crosswise to lengthwise measurements to determine out-of-roundness. If the measurements differ by more than 0.0635 mm (0.0025 in.), ream the guide bore to accommodate an oversize valve stem.

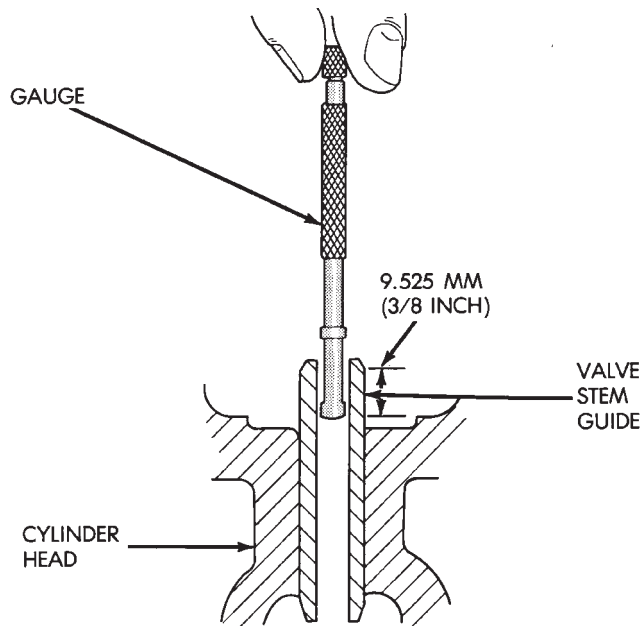

J8909-92

Fig. 10 Measurement of Valve Guide Bore Diameter

(7) Compare the measured valve guide bore diameter with specifications (7.95-7.97 mm or 0.313-0.314 inch). If the measurement differs from specification by more than 0.076 mm (0.003 inch), ream the guide bore to accommodate an oversize valve stem.

ALTERNATIVE METHOD:

(1) Use a dial indicator to measure the lateral movement of the valve stem (stem-to-guide clearance). This must be done with the valve installed in its guide and just off the valve seat (Fig. 11).

(2) Correct clearance is 0.025-0.0762 mm (0.001-0.003 inch). If indicated movement exceeds the specification ream the valve guide to accommodate an oversize valve stem.

Valve seats must be ground after reaming the valve guides to ensure that the valve seat is concentric to the valve guide.

VALVE SPRING TENSION TEST

Use Valve Spring Tester C-647 and a torque wrench to test each valve spring for the specified tension value (Fig. 12).

Replace valve springs that are not within specifications.

INSTALLATION

(1) Thoroughly clean the valve stems and the valve guide bores.

(2) Lightly lubricate the stem.

(3) Install the valve in the original valve guide bore.

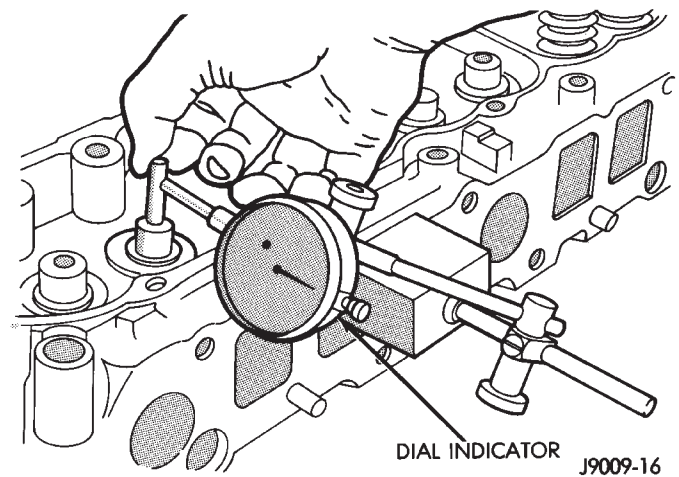

Fig. 11 Measurement of Lateral Movement Of Valve Stem

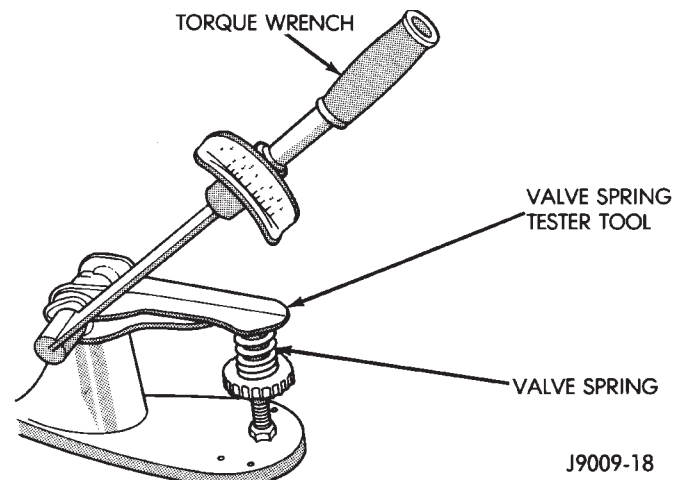

Fig. 12 Valve Spring Tester C-647

(4) Install the replacement valve stem oil seals on the valve stems. If the 0.381 mm (0.015 inch) oversize valve stems are used, oversize oil seals are required.

(5) Position the valve spring and retainer on the engine cylinder head and compress the valve spring with Valve Spring Compressor Tool MD-998772A.

(6) Install the valve locks and release the tool.

(7) Tap the valve spring from side to side with a hammer to ensure that the spring is properly seated at the engine cylinder head. Also tap the top of the retainer to seat the valve locks.

(8) Install the engine cylinder head.

HYDRAULIC TAPPETS

Retain all the components in the same order as removed.

REMOVAL

(1) Remove the engine cylinder head cover.

(2) Remove the bridge and pivot assemblies and rocker arms by removing the capscrews at each bridge. Alternately loosen each capscrew, one turn at

a time, to avoid damaging the bridges.

(3) Remove the push rods.

(4) Remove the tappets through the push rod openings in the cylinder head with Hydraulic Valve Tappet Removal/Installation Tool C-4129-A (Fig. 13).

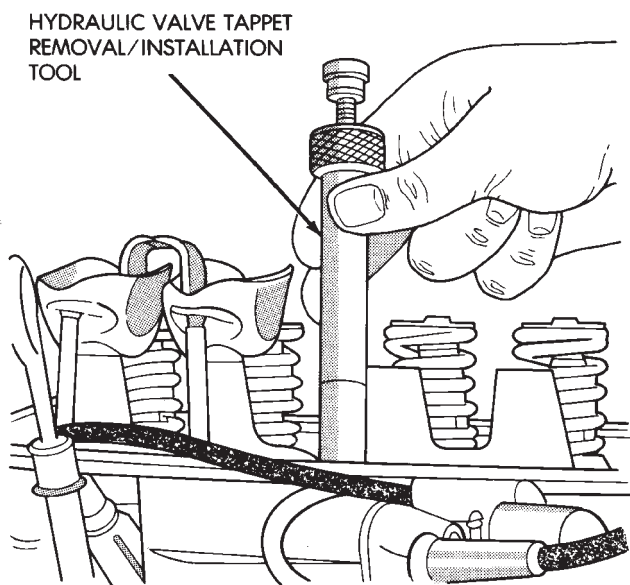

J8909-96

Fig. 13 Hydraulic Valve Tappet Removal/Installation Tool C-4129-A

CLEANING

Clean each tappet assembly in cleaning solvent to remove all varnish, gum and sludge deposits.

INSPECTION

Inspect for indications of scuffing on the side and base of each tappet body.

Inspect each tappet base for concave wear with a straightedge positioned across the base. If the base is concave, the corresponding lobe on the camshaft is also worn. Replace the camshaft and defective tappets.

LEAK-DOWN TEST

After cleaning and inspection, test each tappet for specified leak-down rate tolerance to ensure zero-lash operation (Fig. 14).

Swing the weighted arm of the hydraulic valve tappet tester away from the ram of the Leak-Down Tester 7980.

(1) Place a 7.925-7.950 mm (0.312-0.313 inch) diameter ball bearing on the plunger cap of the tappet.

(2) Lift the ram and position the tappet (with the ball bearing) inside the tester cup.

(3) Lower the ram, then adjust the nose of the ram until it contacts the ball bearing. DO NOT tighten the hex nut on the ram.

(4) Fill the tester cup with hydraulic valve tappet test oil until the tappet is completely submerged.

(5) Swing the weighted arm onto the push rod and pump the tappet plunger up and down to remove air. When the air bubbles cease, swing the weighted arm away and allow the plunger to rise to the normal position.

(6) Adjust the nose of the ram to align the pointer with the SET mark on the scale of the tester and tighten the hex nut.

(7) Slowly swing the weighted arm onto the push rod.

(8) Rotate the cup by turning the handle at the base of the tester clockwise one revolution every 2 seconds.

(9) Observe the leak-down time interval from the instant the pointer aligns with the START mark on the scale until the pointer aligns with the 0.125 mark. A normally functioning tappet will require 20-110 seconds to leak-down. Discard tappets with leak-down time interval not within this specification.

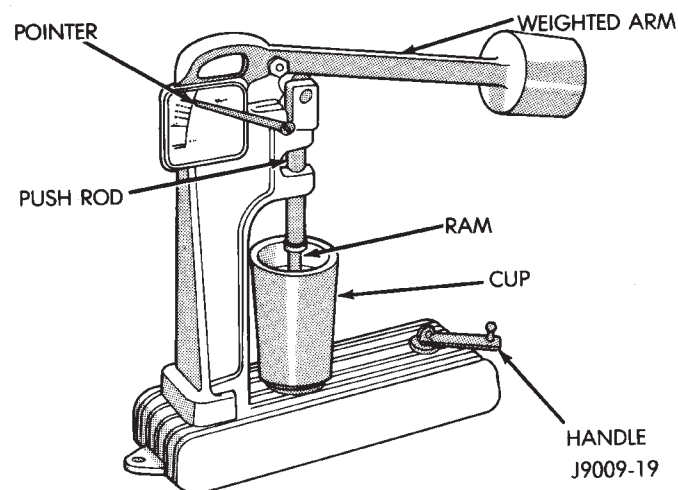

Fig. 14 Leak-Down Tester 7980

INSTALLATION

It is not necessary to charge the tappets with engine oil. They will charge themselves within a very short period of engine operation.

(1) Dip each tappet in Mopar Engine Oil Supplement, or equivalent.

(2) Use Hydraulic Valve Tappet Removal/Installation Tool C-4129-A to install each tappet in the same bore from where it was originally removed.

(3) Install the push rods in their original locations.

(4) Install the rocker arms and bridge and pivot assemblies at their original locations. Loosely install the capscrews at each bridge.

(5) Tighten the capscrews alternately, one turn at a time, to avoid damaging the bridges. Tighten the capscrews to 28 N·m (21 ft. lbs.) torque.

(6) Pour the remaining Mopar Engine Oil Supplement, or equivalent over the entire valve actuating assembly. The Mopar Engine Oil Supplement, or equivalent must remain with the engine oil for at

least 1 600 km (1,000 miles). The oil supplement need not be drained until the next scheduled oil change.

(7) Install the engine cylinder head cover.

VALVE TIMING

Disconnect the spark plug wires and remove the spark plugs.

Remove the engine cylinder head cover.

Remove the capscrews, bridge and pivot assembly, and rocker arms from above the No.1 cylinder.

Alternately loosen each capscrew, one turn at a time, to avoid damaging the bridge.

Rotate the crankshaft until the No.4 piston is at top dead center (TDC) on the compression stroke.

Rotate the crankshaft counterclockwise (viewed from the front of the engine) 90°.

Install a dial indicator on the end of the No.1 cylinder intake valve push rod. Use rubber tubing to secure the indicator stem on the push rod.

Set the dial indicator pointer at zero.

Rotate the crankshaft clockwise (viewed from the front of the engine) until the dial indicator pointer indicates 0.305 mm (0.012 inch) travel distance (lift).

The timing notch index on the vibration damper should be aligned with the TDC mark on the timing degree scale.

If the timing notch is more than 13 mm (1/2 inch) away from the TDC mark in either direction, the valve timing is incorrect.

If the valve timing is incorrect, the cause may be a broken camshaft pin. It is not necessary to replace the camshaft because of pin failure. A spring pin is available for service replacement.

VIBRATION DAMPER

REMOVAL

(1) Disconnect negative cable from battery.

(2) Remove the serpentine drive belt and fan shroud.

(3) Remove the vibration damper retaining bolt and washer.

(4) Use Vibration Damper Removal Tool 8068 to remove the damper from the crankshaft (Fig. 1).

INSTALLATION

(1) Apply Mopar Silicone Rubber Adhesive Sealant to the keyway in the crankshaft and insert the key. With the key in position, align the keyway on the vibration damper hub with the crankshaft key and tap the damper onto the crankshaft.

(2) Install the vibration damper retaining bolt and washer.

(3) Tighten the damper retaining bolt to 108 N·m (80 ft. lbs.) torque.

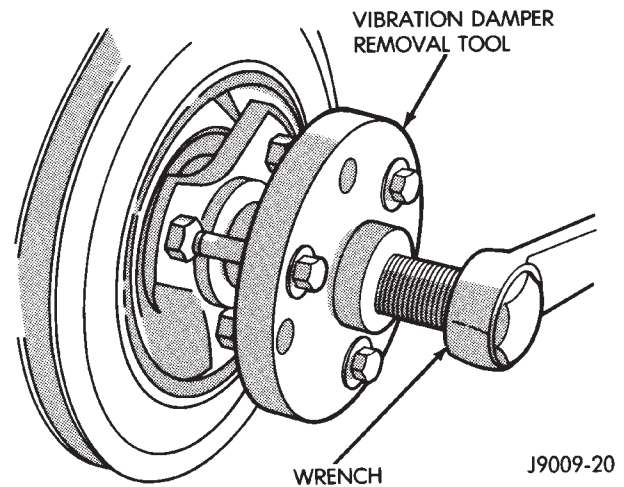

Fig. 1 Vibration Damper Removal Tool 8068

(4) Install the serpentine drive belt and tighten to the specified tension (refer to Group 7, Cooling Systems for the proper specifications and procedures).

(5) Connect negative cable to battery.

TIMING CASE COVER OIL SEAL REPLACEMENT

This procedure is done with the timing case cover installed.

(1) Disconnect negative cable from battery.

(2) Remove the serpentine drive belt.

(3) Remove the vibration damper.

(4) Remove the radiator shroud.

(5) Carefully remove the oil seal (Fig. 2). Make sure seal bore is clean.

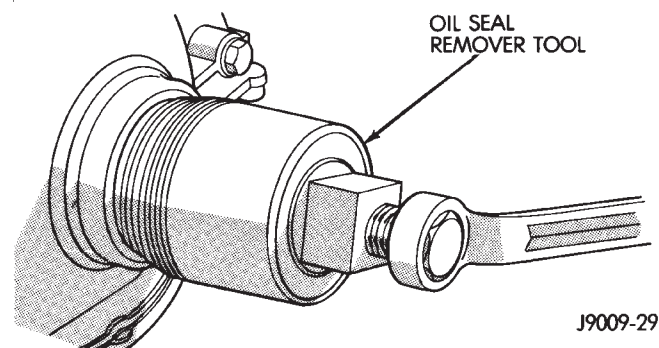

Fig. 2 Timing Case Cover Oil Seal Removal

(6) Position the replacement oil seal on Timing Case Cover Alignment and Seal Installation Tool 6139 with seal open end facing inward. Apply a light film of Perfect Seal, or equivalent, on the outside diameter of the seal. Lightly coat the crankshaft with engine oil.

(7) Position the tool and seal over the end of the crankshaft and insert a draw screw tool into Seal Installation Tool 6139 (Fig. 3). Tighten the nut against the tool until it contacts the cover.

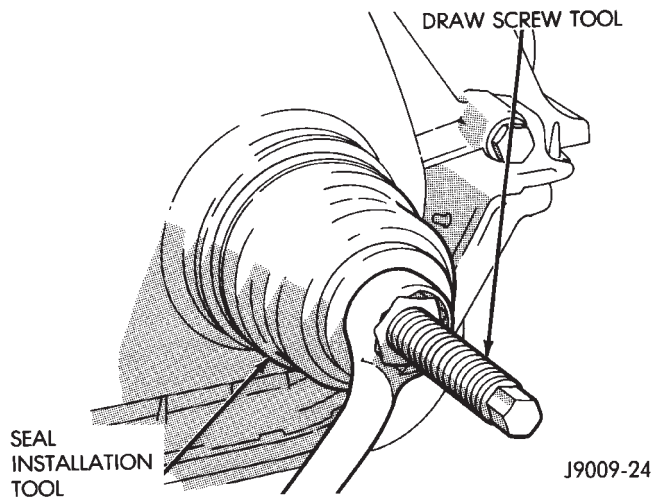

Fig. 3 Timing Case Cover Oil Seal Installation

(8) Remove the tools. Apply a light film of engine oil on the vibration damper hub contact surface of the seal.

(9) Apply Mopar Silicone Rubber Adhesive Sealant to the keyway in the crankshaft and insert the key. With the key inserted in the keyway in the crankshaft, install the vibration damper, washer and bolt. Lubricate and tighten the bolt to 108 N·m (80 ft. lbs.) torque.

(10) Install the serpentine belt and tighten to the specified tension (refer to Group 7, Cooling Systems for the proper specifications and procedures).

(11) Install the radiator shroud.

(12) Connect negative cable to battery.

TIMING CASE COVER

REMOVAL

(1) Disconnect negative cable from battery.

(2) Remove the vibration damper (Fig. 4).

(3) Remove the fan and hub assembly and remove the fan shroud.

(4) Remove the accessory drive brackets that are attached to the timing case cover.

(5) Remove the A/C compressor (if equipped) and generator bracket assembly from the engine cylinder head and move to one side.

(6) Remove the oil pan-to-timing case cover bolts and timing case cover-to-cylinder block bolts.

(7) Remove the timing case cover and gasket from the engine.

(8) Pry the crankshaft oil seal from the front of the timing case cover (Fig. 4).

CLEANING

Clean the timing case cover, oil pan and cylinder block gasket surfaces.

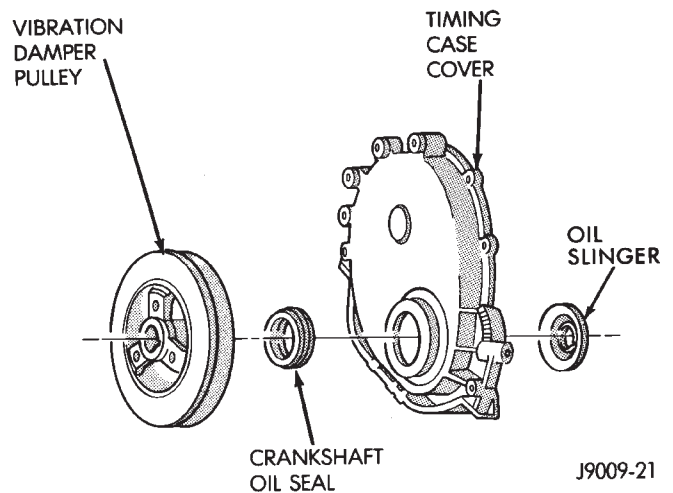

Fig. 4 Timing Case Cover Components

INSTALLATION

(1) Install a new crankshaft oil seal in the timing case cover. The open end of the seal should be toward the inside of the cover. Support the cover at the seal area while installing the seal. Force it into position with Seal Installation Tool 6139.

(2) Position the gasket on the cylinder block.

(3) Position the timing case cover on the oil pan gasket and the cylinder block.

(4) Insert Timing Case Cover Alignment and Seal Installation Tool 6139 in the crankshaft opening in the cover (Fig. 5).

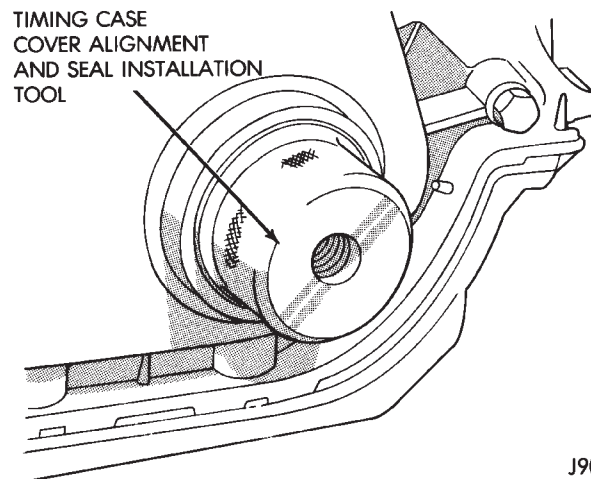

Fig. 5 Timing Case Cover Alignment and Seal Installation Tool 6139

(5) Install the timing case cover-to-cylinder block and the oil pan-to-timing case cover bolts.

(6) Tighten the 1/4 inch cover-to-block bolts to 7 N·m (60 in. lbs.) torque. Tighten the 5/16 inch front cover-to-block bolts to 22 N·m (192 in. lbs.) torque. Tighten the oil pan-to-cover 1/4 inch bolts to 14 N·m (120 in. lbs.) torque. Tighten the oil pan-to-cover 5/16 inch bolts to 18 N·m (156 in. lbs.) torque.

(7) Remove the cover alignment tool.

(8) Apply a light film of engine oil on the vibration damper hub contact surface of the seal.

(9) Apply Mopar Silicone Rubber Adhesive Sealant to the keyway in the crankshaft and insert the key. With the key inserted in the keyway in the crankshaft, install the vibration damper, washer and bolt. Lubricate and tighten the bolt to 108 N·m (80 ft. lbs.) torque.

(10) Install the A/C compressor (if equipped) and generator bracket assembly.

(11) Install the engine fan and hub assembly and shroud.

(12) Install the serpentine drive belt and tighten to obtain the specified tension.

(13) Connect negative cable to battery.

TIMING CHAIN AND SPROCKETS

The timing chain tensioner reduces noise and prolongs timing chain life. In addition, it compensates for slack in a worn or stretched chain and maintains the correct valve timing.

REMOVAL

- (1) Disconnect negative cable from battery.
- (2) Remove the fan and shroud.
- (3) Remove the serpentine drive belt.
- (4) Remove the crankshaft vibration damper.
- (5) Remove the timing case cover.
- (6) Rotate crankshaft until the "0" timing mark is closest to and on the center line with camshaft sprocket timing mark (Fig. 6).

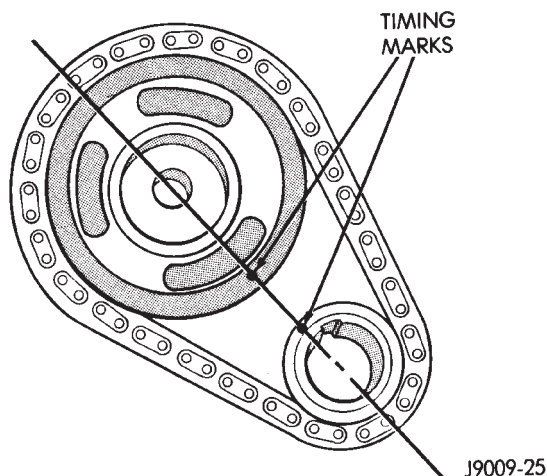

Fig. 6 Crankshaft/Camshaft Alignment

- (7) Remove the oil slinger from the crankshaft.
- (8) Remove the camshaft retaining bolt and remove the sprockets and chain as an assembly (Fig. 7).
- (9) To replace the timing chain tensioner, the oil pan must be removed.

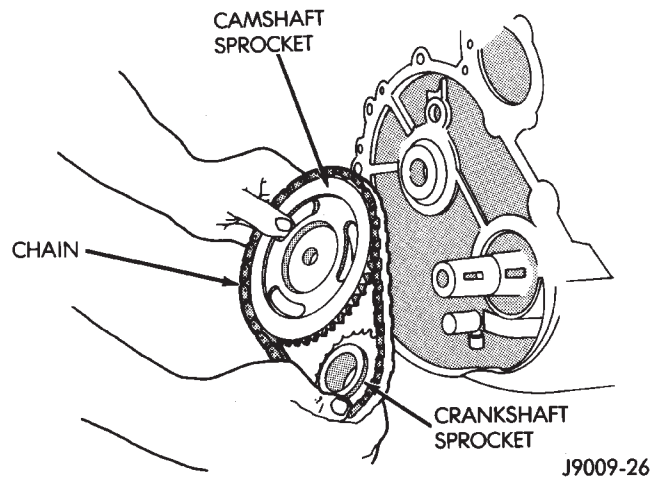

Fig. 7 Camshaft and Crankshaft Sprockets and Chain

INSTALLATION

- (1) Turn the tensioner lever to the unlocked (down) position (Fig. 8).
- (2) Pull the tensioner block toward the tensioner lever to compress the spring. Hold the block and turn the tensioner lever to the lock position (Fig. 8).

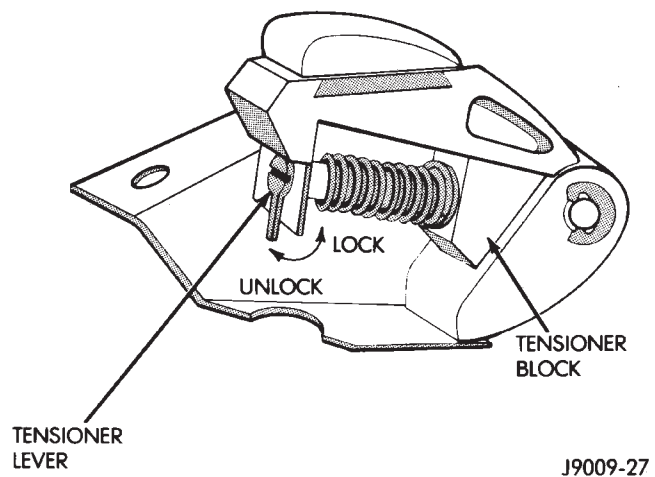

Fig. 8 Loading Timing Chain Tensioner

(3) Apply Mopar Silicone Rubber Adhesive Sealant to the keyway in the crankshaft and insert the key. With the key in the crankshaft keyway, install the crankshaft/camshaft sprockets and timing chain. Ensure the timing marks on the sprockets are properly aligned (Fig. 6).

(4) Install the camshaft sprocket retaining bolt and washer. Tighten the bolt to 108 N·m (80 ft. lbs.) torque.

(5) To verify correct installation of the timing chain, turn the crankshaft to position the camshaft sprocket timing mark as shown in Fig. 9. Count the number of chain pins between the timing marks of both sprockets. There must be 20 pins.

(6) Turn the chain tensioner lever to the unlocked (down) position (Fig. 8).

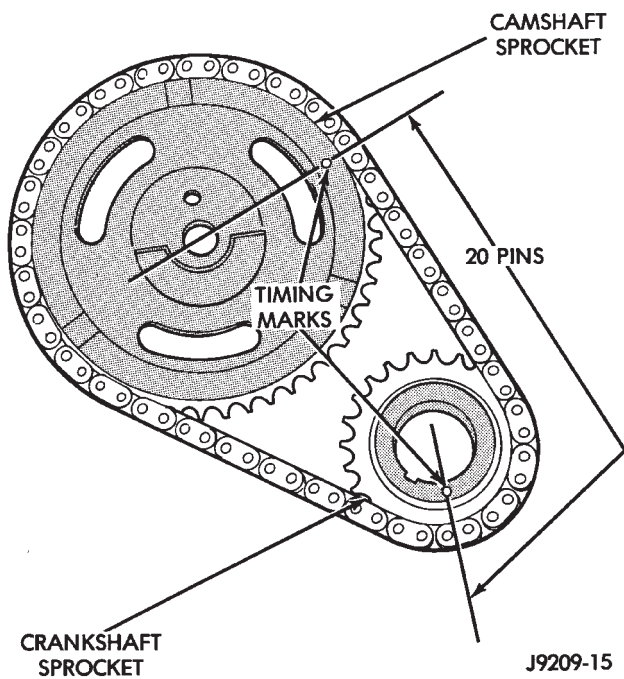

Fig. 9 Verify Sprocket/Chain Installation

- (7) Install the oil slinger.
- (8) Replace the oil seal in the timing case cover.
- (9) Install the timing case cover and gasket.
- (10) With the key inserted in the keyway in the crankshaft, install the vibration damper, washer and bolt. Lubricate and tighten the bolt to 108 N·m (80 ft. lbs.) torque.
- (11) Install the fan and shroud.
- (12) Connect negative cable to battery.

CAMSHAFT

REMOVAL

WARNING: THE COOLANT IN A RECENTLY OPERATED ENGINE IS HOT AND PRESSURIZED. RELEASE THE PRESSURE BEFORE REMOVING THE DRAIN COCK, CAP AND DRAIN PLUGS.

- (1) Disconnect negative cable from battery.
- (2) Drain the cooling system. DO NOT waste reusable coolant. If the solution is clean, drain it into a clean container for reuse.
- (3) Remove the radiator or radiator/condenser, if equipped with A/C (refer to Group 7, Cooling System for the proper procedure).
- (4) Scribe a mark on the distributor housing in line with the lip of the rotor.
- (5) Scribe a mark on the distributor housing near the clamp and continue the scribe mark on the cylinder block in line with the distributor mark.
- (6) For ease of installation, note the position of the rotor and distributor housing in relation to adjacent engine components.
- (7) Remove the distributor and ignition wires.

- (8) Remove the engine cylinder head cover.
- (9) Remove the rocker arms, bridges and pivots.
- (10) Remove the push rods.
- (11) Remove the hydraulic valve tappets from the engine cylinder head.
- (12) Remove the vibration damper.
- (13) Remove the timing case cover.
- (14) Remove the timing chain and sprockets.
- (15) Remove the camshaft (Fig. 10).

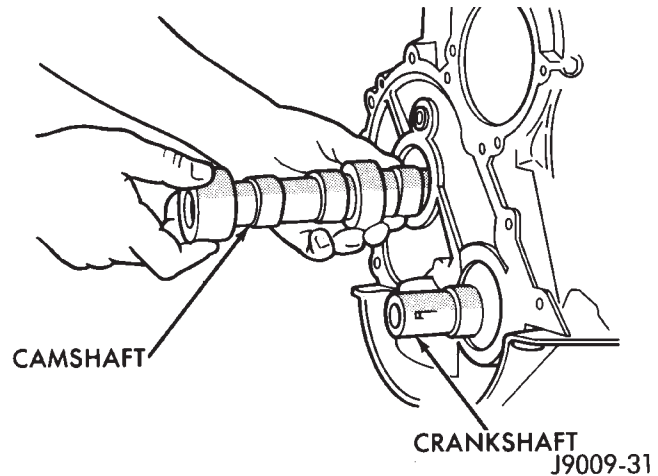

Fig. 10 Camshaft

INSPECTION

- Inspect the cam lobes for wear.
 - Inspect the bearing journals for uneven wear pattern or finish.
 - Inspect the bearings for wear.
 - Inspect the distributor drive gear for wear.
- If the camshaft appears to have been rubbing against the timing case cover, examine the oil pressure relief holes in the rear cam journal. The oil pressure relief holes must be free of debris.

INSTALLATION

- (1) Lubricate the camshaft with Mopar Engine Oil Supplement, or equivalent.
- (2) Carefully install the camshaft to prevent damage to the camshaft bearings (Fig. 10).
- (3) Install the timing chain, crankshaft sprocket and camshaft sprocket with the timing marks aligned.
- (4) Install the camshaft sprocket retaining bolt and washer. Tighten the bolt to 108 N·m (80 ft. lbs.) torque.
- (5) Install the timing case cover with a replacement oil seal (Fig. 11). Refer to Timing Case Cover Installation.
- (6) Install the vibration damper.
- (7) Install the hydraulic valve tappets.
- (8) Install the push rods.
- (9) Install the rocker arms, bridges and pivots.
- (10) Install the engine cylinder head cover.
- (11) Install the distributor and ignition wires.

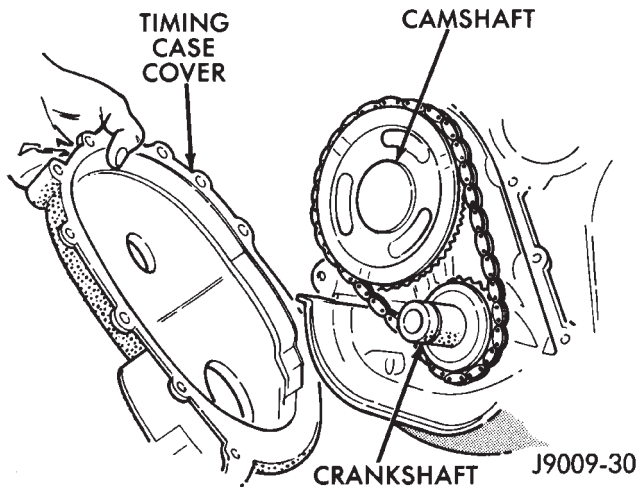

Fig. 11 Timing Case Cover

(12) Properly position the distributor rotor as follows:

- (a) Remove No.1 spark plug. Hold your finger over the spark plug hole and rotate the crankshaft until compression pressure is felt. Slowly continue to rotate the crankshaft until the timing index on the vibration damper aligns with the top dead center (TDC) mark (0° on the timing degree scale). **Always rotate the crankshaft clockwise (the direction of normal rotation). DO NOT rotate the crankshaft backward to align the timing marks.**
- (b) Rotate the oil pump gear so that the gear slot on the oil pump shaft is slightly past the 3 o'clock position (Fig. 12). A flat blade screwdriver can be used to rotate the gear.

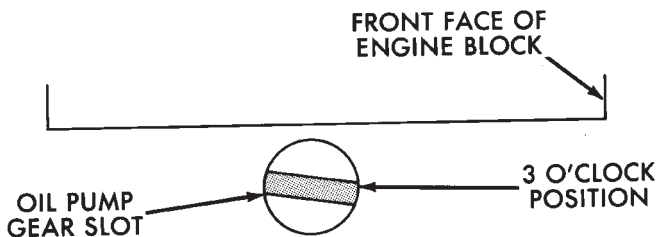

Fig. 12 Oil Pump Gear Slot Alignment

(c) Turn the distributor shaft until the rotor tip points in the direction of No.1 terminal in the distributor cap. Turn the rotor 1/8 turn counterclockwise past the position of No.1 terminal.

(d) With the distributor cap removed, start the distributor into the cylinder block with the rotor located at the 5 o'clock position (Fig. 13).

(e) Slide the distributor shaft down into the engine. Position the distributor vacuum advance mechanism housing in approximately the same location as when removed. Align the scribe mark on

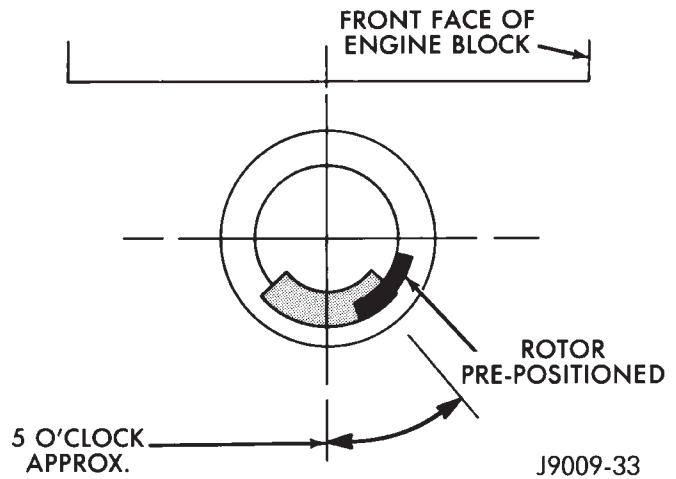

Fig. 13 Distributor Rotor Pre-Positioning

the distributor housing with the corresponding scribe mark on the cylinder block. The rotor should align with the position of No.1 terminal when the distributor shaft is down in place. It may be necessary to rotate the oil pump shaft with a long flat-blade screwdriver to engage the oil pump drive tang.

(f) Install the distributor holddown clamp and bolt. DO NOT tighten the bolt.

(g) When the distributor is fully engaged in its correct location, the rotor should be at the 6 o'clock position (Fig. 14).

(h) If the distributor is not properly installed, or if it is removed later, then the complete installation procedures must be repeated.

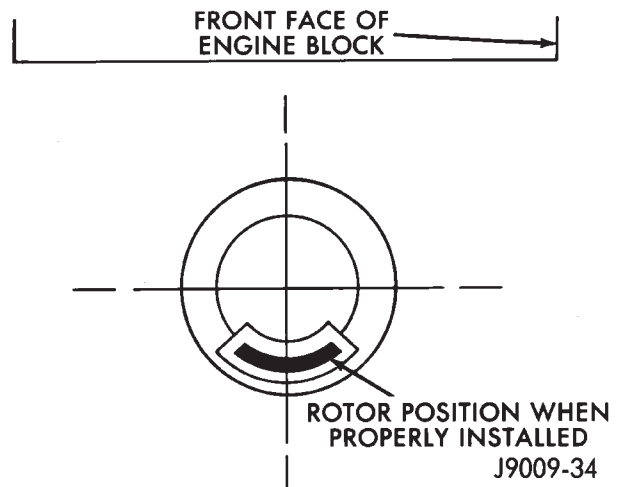

Fig. 14 Correct Rotor Position

(13) Install the radiator or radiator/condenser, if equipped with A/C.

(14) Fill the cooling system.

(15) Connect negative cable to battery.

CAMSHAFT PIN REPLACEMENT

REMOVAL

WARNING: DO NOT LOOSEN THE RADIATOR DRAIN COCK WITH THE SYSTEM HOT AND PRESSURIZED BECAUSE SERIOUS BURNS FROM COOLANT CAN OCCUR.

- (1) Disconnect negative cable from battery.
- (2) Drain the radiator. **DO NOT** waste reusable coolant. Drain the coolant into a clean container.
- (3) Remove the fan and shroud.
- (4) Disconnect the radiator overflow tube, radiator hoses, automatic transmission fluid cooler pipes (if equipped).
- (5) Remove the radiator.
- (6) If equipped with air conditioning:

CAUTION: DO NOT loosen or disconnect any air conditioner system fittings. Move the condenser and receiver/drier aside as a complete assembly.

- (a) Remove the A/C compressor serpentine drive belt idler pulley.
- (b) Disconnect and remove the generator.
- (c) Remove the A/C condenser attaching bolts and move the condenser and receiver/drier assembly up and out of the way.
- (7) Remove the serpentine drive belt.
- (8) Remove the crankshaft vibration damper.
- (9) Remove the timing case cover. Clean the gasket material from the cover.
- (10) Rotate crankshaft until the crankshaft sprocket timing mark is closest to and on the center line with the camshaft sprocket timing mark (Fig. 15).

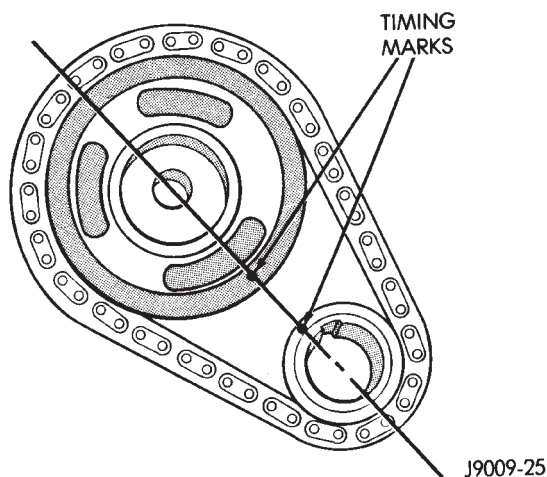

Fig. 15 Timing Chain Alignment

- (11) Remove camshaft sprocket retaining bolt.
- (12) Remove the crankshaft oil slinger.
- (13) Remove the sprockets and chain as an assembly (Fig. 16).

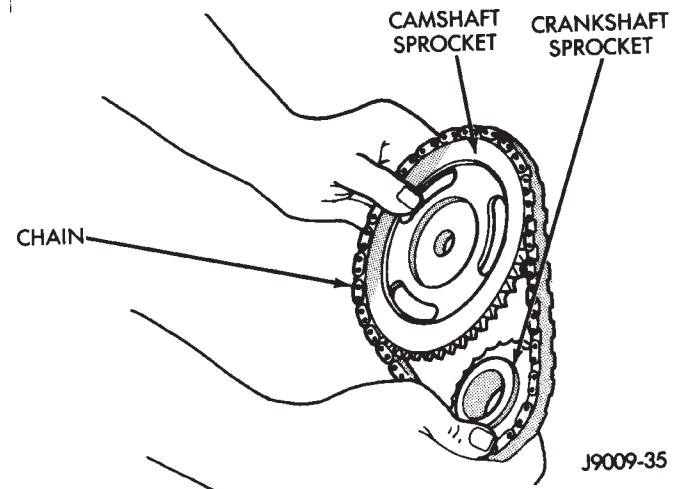

Fig. 16 Camshaft and Crankshaft Sprocket and Chain

CAUTION: The following procedural step must be accomplished to prevent the camshaft from damaging the rear camshaft plug during pin installation.

- (14) Inspect the damaged camshaft pin.
- (15) If the pin is a spring-type pin, remove the broken pin by inserting a self-tapping screw into the pin and carefully pulling the pin from the camshaft.
- (16) If the pin is a dowel-type pin, center-punch it. Ensure the exact center is located when center-punching the pin.

CAUTION: Cover the opened oil pan area to prevent metal chips from entering the pan.

- (17) Drill into the pin center with a 4 mm (5/32 inch) drill bit.
- (18) Insert a self-tapping screw into the drilled pin and carefully pull the pin from the camshaft.

CAMSHAFT BEARINGS

The camshaft rotates within four steel-shelled, babbit-lined bearings that are pressed into the cylinder block and then line reamed. The camshaft bearing bores and bearing diameters are not the same size. They are stepped down in 0.254 mm (0.010 inch) increments from the front bearing (largest) to the rear bearing (smallest). This permits easier removal and installation of the camshaft. The camshaft bearings are pressure lubricated.

It is not advisable to attempt to replace camshaft bearings unless special removal and installation tools are available.

Camshaft end play is maintained by the load placed on the camshaft by the oil pump and distributor drive gear. The helical cut of the gear holds the camshaft sprocket thrust face against the cylinder block face.

INSTALLATION

- (1) Clean the camshaft pin hole.
- (2) Compress the center of the replacement spring pin with vise grips.
- (3) Carefully drive the pin into the camshaft pin hole until it is seated.
- (4) Install the camshaft sprocket, crankshaft sprocket and timing chain with the timing marks aligned (Fig. 15).
- (5) To verify correct installation of the timing chain, turn the crankshaft to position the camshaft sprocket timing mark as shown in Fig. 17. Count the number of chain pins between the timing marks of both sprockets. There must be 20 pins.

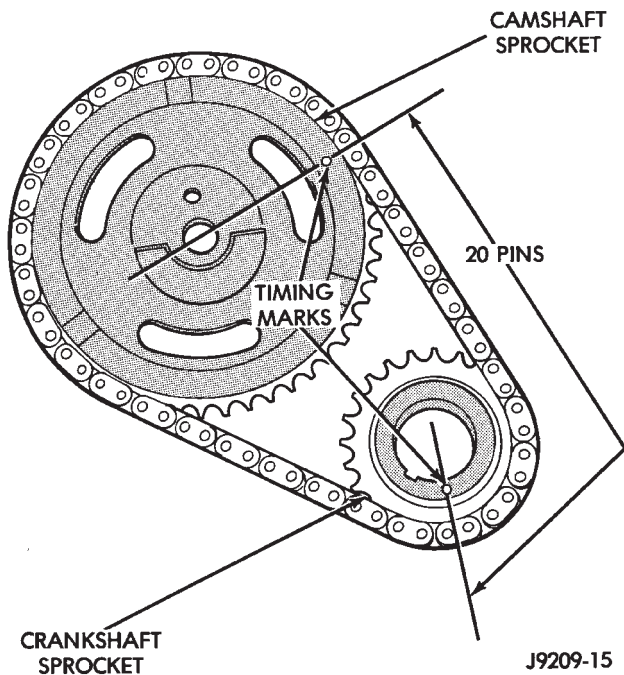

Fig. 17 Verify Crankshaft/Camshaft Installation

- (6) Install the crankshaft oil slinger.
- (7) Tighten the camshaft sprocket bolt to 108 N·m (80 ft. lbs.) torque.
- (8) Check the valve timing.
- (9) Coat both sides of the replacement timing case cover gasket with gasket sealer. Apply a 3 mm (1/8 inch) bead of Mopar Silicone Rubber Adhesive Sealant, or equivalent to the joint formed at the timing case cover and cylinder block.
- (10) Position the timing case cover on the oil pan gasket and the cylinder block.
- (11) Place Timing Case Cover Alignment and Seal Installation Tool 6139 in the crankshaft opening of the cover (Fig. 18).
- (12) Install the timing case cover-to-cylinder block bolts. Install the oil pan-to-timing case cover bolts.
- (13) Tighten the 1/4 inch cover-to-block bolts to 7 N·m (60 in. lbs.) torque. Tighten the 5/16 inch front cover-to-block bolts to 22 N·m (192 in. lbs.) torque. Tighten the oil pan-to-cover 1/4 inch bolts to 14 N·m

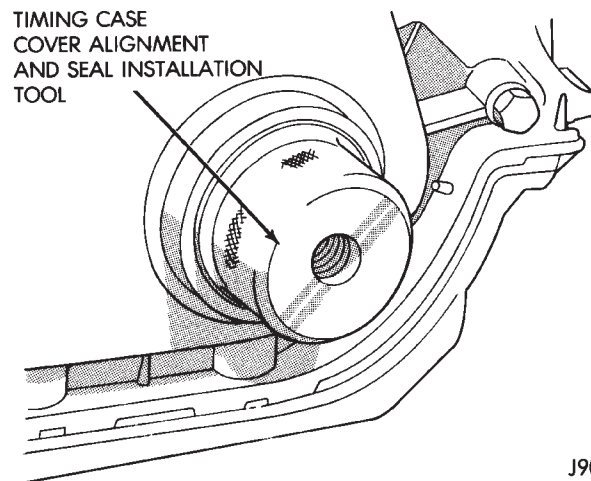

Fig. 18 Timing Case Cover Alignment and Seal Installation Tool 6139

(120 in. lbs.) torque. Tighten the oil pan-to-cover 5/16 inch bolts to 18 N·m (156 in. lbs.) torque.

- (14) Remove the cover alignment tool and install a replacement oil seal into the cover.
- (15) Install the vibration damper on the crankshaft.
- (16) Lubricate and tighten the damper bolt to 108 N·m (80 ft. lbs.) torque.
- (17) If equipped with air conditioning:
 - (a) Install the A/C compressor serpentine drive belt idler pulley.
 - (b) Install the generator.
 - (c) Install the A/C condenser and receiver/drier assembly.
- (18) Install the serpentine drive belt on the pulleys and tighten (refer to Group 7, Cooling System for the specifications and procedures).
- (19) Install the radiator. Connect the radiator hoses and automatic transmission fluid cooler pipes, if equipped. Fill the cooling system.
- (20) Install the fan and shroud.
- (21) Connect negative cable to battery.

OIL PAN**REMOVAL**

- (1) Disconnect negative cable from battery.
- (2) Raise the vehicle.
- (3) Remove the oil pan drain plug and drain the engine oil.
- (4) Disconnect the exhaust pipe at the engine exhaust manifold.
- (5) Disconnect the exhaust hanger at the catalytic converter and lower the pipe.
- (6) Remove the engine starter motor.
- (7) Remove the flywheel/torque converter housing access cover.
- (8) Position a jack stand directly under the engine vibration damper.

(9) Place a piece of wood (2 x 2) between the jack stand and the engine vibration damper.

(10) Remove the engine mount through bolts.

(11) Using the jack stand, raise the engine until adequate clearance is obtained to remove the oil pan.

(12) Remove the oil pan bolts. Carefully remove the oil pan and gasket.

CLEANING

Clean the block and pan gasket surfaces.

INSTALLATION

(1) Fabricate 4 alignment dowels from 1 1/2 x 1/4 inch bolts. Cut the head off the bolts and cut a slot into the top of the dowel. This will allow easier installation and removal with a screwdriver (Fig. 1).

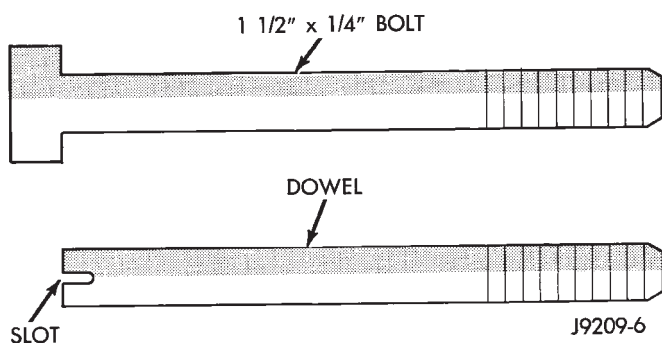

Fig. 1 Fabrication of Alignment Dowels

(2) Install two dowels in the timing case cover. Install the other two dowels in the cylinder block (Fig. 2).

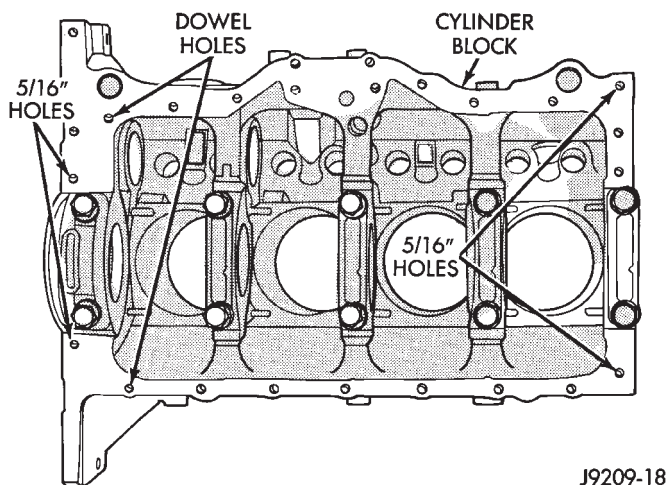

Fig. 2 Position of Dowels in Cylinder Block

(3) Slide the one-piece gasket over the dowels and onto the block and timing case cover.

(4) Position the oil pan over the dowels and onto the gasket.

(5) Install the 1/4 inch oil pan bolts. Tighten these bolts to 14 N·m (120 in. lbs.) torque. Install the 5/16 inch oil pan bolts (Fig. 3). Tighten these bolts to 18 N·m (156 in. lbs.) torque.

Ⓐ 5/16" BOLTS

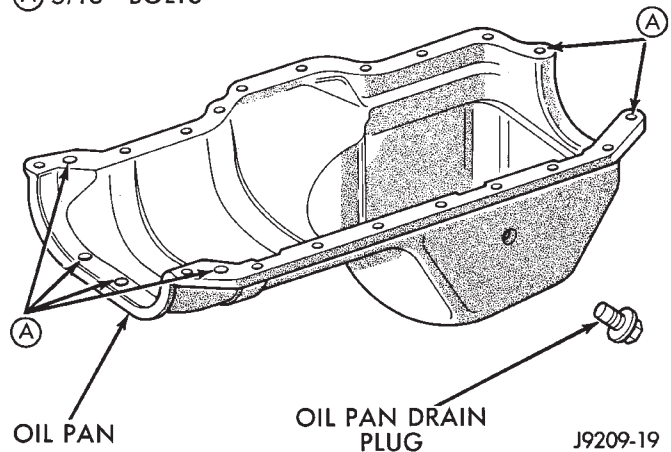

Fig. 3 Position of 5/16 inch Oil Pan Bolts

(6) Remove the dowels. Install the remaining 1/4 inch oil pan bolts. Tighten these bolts to 14 N·m (120 in. lbs.) torque.

(7) Lower the engine until it is properly located on the engine mounts.

(8) Install the through bolts and tighten the nuts.

(9) Lower the jack stand and remove the piece of wood.

(10) Install the flywheel/torque converter housing access cover.

(11) Install the engine starter motor.

(12) Connect the exhaust pipe to the hanger and to the engine exhaust manifold.

(13) Install the oil pan drain plug (Fig. 3). Tighten the plug to 34 N·m (25 ft. lbs.) torque.

(14) Lower the vehicle.

(15) Connect negative cable to battery.

(16) Fill the oil pan with engine oil to the specified level.

WARNING: USE EXTREME CAUTION WHEN THE ENGINE IS OPERATING. DO NOT STAND IN A DIRECT LINE WITH THE FAN. DO NOT PUT YOUR HANDS NEAR THE PULLEYS, BELTS OR FAN. DO NOT WEAR LOOSE CLOTHING.

(17) Start the engine and inspect for leaks.

OIL PUMP

The positive-displacement gear-type oil pump is driven by the distributor shaft, which is driven by a gear on the camshaft. Oil is siphoned into the pump through an inlet tube and strainer assembly that is pressed into the pump body.

The pump incorporates a nonadjustable pressure relief valve to limit maximum pressure to 517 kPa

(75 psi). In the relief position, the valve permits oil to bypass through a passage in the pump body to the inlet side of the pump.

Oil pump removal or replacement will not affect the distributor timing because the distributor drive gear remains in mesh with the camshaft gear.

REMOVAL

- (1) Drain the engine oil.
- (2) Remove the oil pan.
- (3) Remove the pump-to-cylinder block attaching bolts. Remove the pump assembly with gasket (Fig. 4).

CAUTION: If the oil pump is not to be serviced, DO NOT disturb position of oil inlet tube and strainer assembly in pump body. If the tube is moved within the pump body, a replacement tube and strainer assembly must be installed to assure an airtight seal.

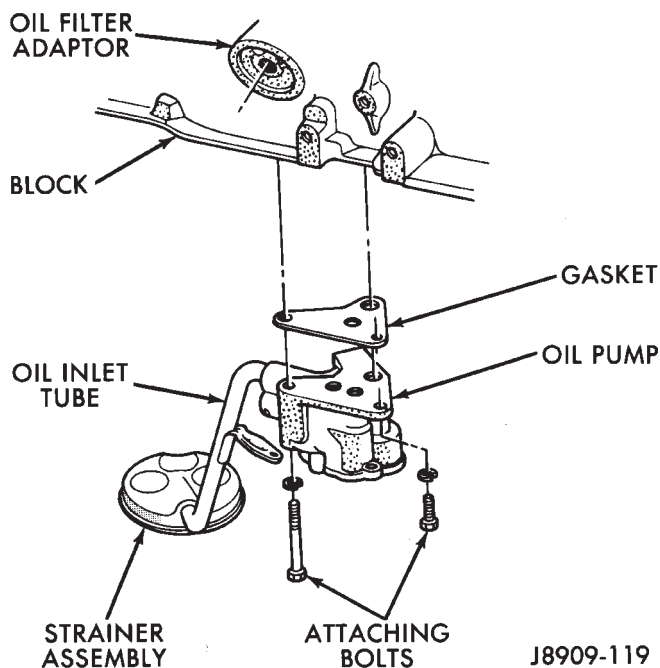

Fig. 4 Oil Pump Assembly

INSTALLATION

- (1) Install the oil pump on the cylinder block using a replacement gasket. Tighten the short bolt to 14 N·m (10 ft. lbs.) torque and the long bolt to 23 N·m (17 ft. lbs.) torque.
- (2) Install the oil pan.
- (3) Fill the oil pan with oil to the specified level.

OIL PUMP PRESSURE

The MINIMUM oil pump pressure is 89.6 kPa (13 psi) at 600 rpm. The MAXIMUM oil pump pressure is 255-517 kPa (37-75 psi) at 1600 rpm or more.

PISTONS AND CONNECTING RODS

REMOVAL

- (1) Remove the engine cylinder head cover.
- (2) Remove the rocker arms, bridges and pivots.
- (3) Remove the push rods.
- (4) Remove the engine cylinder head.
- (5) Position the pistons one at a time near the bottom of the stroke. Use a ridge reamer to remove the ridge from the top end of the cylinder walls. Use a protective cloth to collect the cuttings.
- (6) Raise the vehicle.
- (7) Drain the engine oil.
- (8) Remove the oil pan and gasket.
- (9) Remove the connecting rod bearing caps and inserts. Mark the caps and rods with the cylinder bore location. The connecting rods and caps are stamped with a two letter combination (Fig. 1).

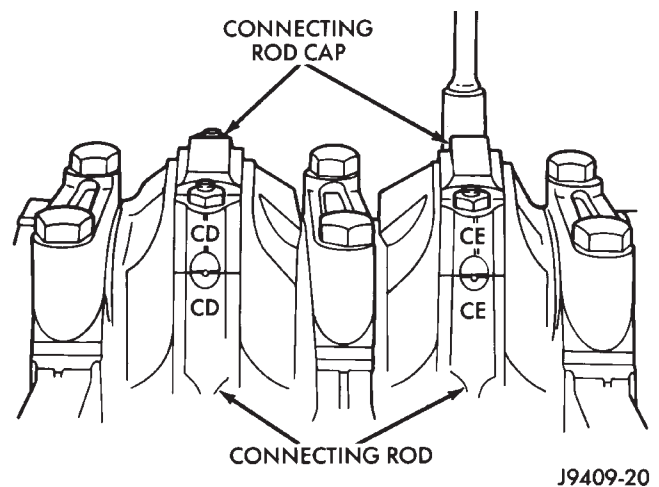

Fig. 1 Stamped Connecting Rods and Caps

- (10) Lower the vehicle until it is about 2 feet from the floor.

CAUTION: Ensure that the connecting rod bolts DO NOT scratch the crankshaft journals or cylinder walls. Short pieces of rubber hose, slipped over the rod bolts will provide protection during removal.

- (11) Have an assistant push the piston/connecting rod assemblies up and through the top of the cylinder bores (Fig. 2).

INSPECTION—CONNECTING ROD

CONNECTING ROD BEARINGS

Inspect the connecting rod bearings for scoring and bent alignment tabs (Figs. 3 and 4). Check the bearings for normal wear patterns, scoring, grooving, fatigue and pitting (Fig. 5). Replace any bearing that shows abnormal wear.

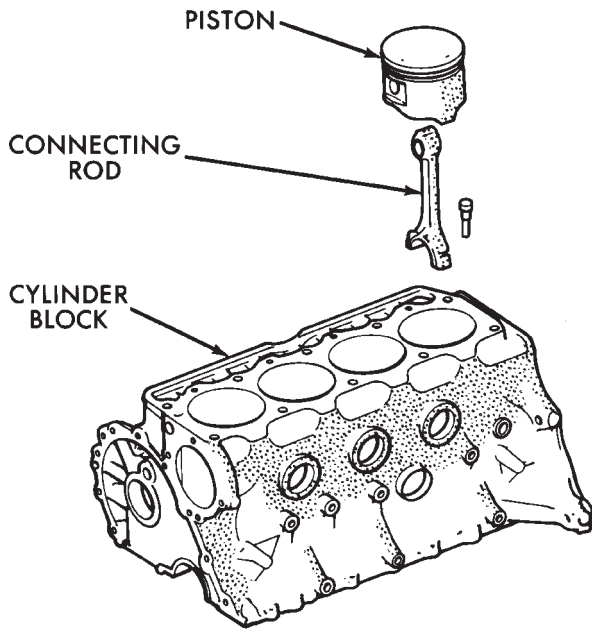

J8909-126

Fig. 2 Removal of Connecting Rod and Piston Assembly

Inspect the connecting rod journals for signs of scoring, nicks and burrs.

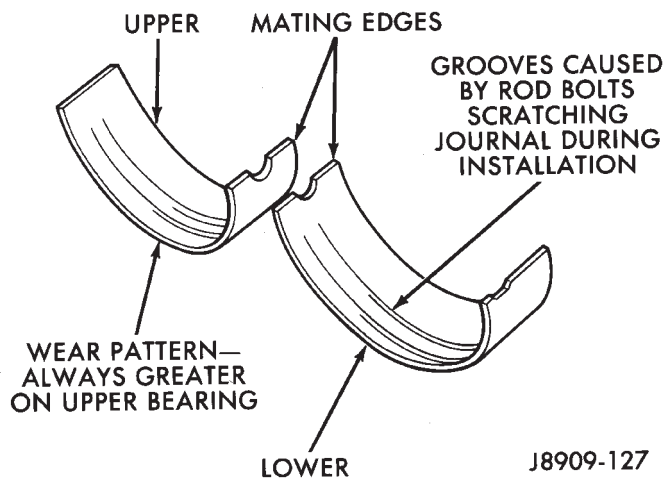

J8909-127

Fig. 3 Connecting Rod Bearing Inspection

CONNECTING RODS

Misaligned or bent connecting rods can cause abnormal wear on pistons, piston rings, cylinder walls, connecting rod bearings and crankshaft connecting rod journals. If wear patterns or damage to any of these components indicate the probability of a misaligned connecting rod, inspect it for correct rod alignment. Replace misaligned, bent or twisted connecting rods.

BEARING-TO-JOURNAL CLEARANCE

- (1) Wipe the oil from the connecting rod journal.

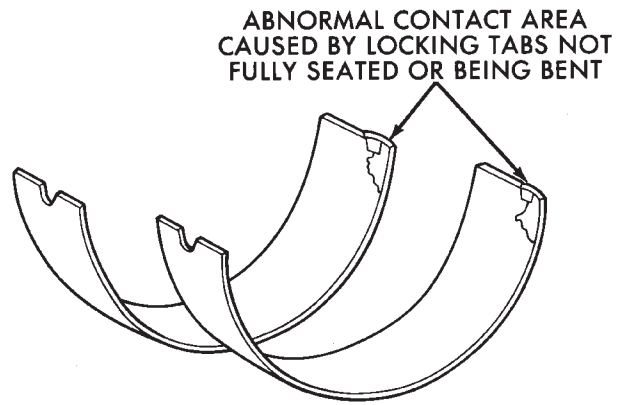

J8909-128

Fig. 4 Locking Tab Inspection

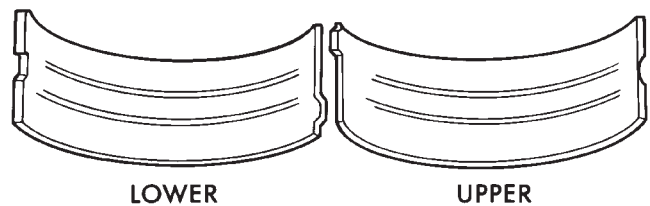

J8909-129

Fig. 5 Scoring Caused by Insufficient Lubrication or by Damaged Crankshaft Pin Journal

- (2) Use short rubber hose sections over rod bolts during installation.
- (3) Lubricate the upper bearing insert and install in connecting rod.
- (4) Use piston ring compressor to install the rod and piston assemblies. The oil squirt holes in the rods must face the camshaft. The arrow on the piston crown should point to the front of the engine (Fig. 6). Verify that the oil squirt holes in the rods face the camshaft and that the arrows on the pistons face the front of the engine.

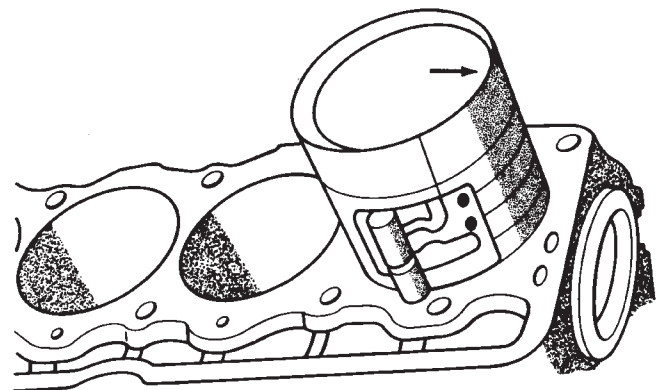

J9009-41

Fig. 6 Rod and Piston Assembly Installation

- (5) Install the lower bearing insert in the bearing cap. The lower insert must be dry. Place strip of

Plastigage across full width of the lower insert at the center of bearing cap. Plastigage must not crumble in use. If brittle, obtain fresh stock.

(6) Install bearing cap and connecting rod on the journal and tighten nuts to 45 N·m (33 ft. lbs.) torque. DO NOT rotate crankshaft. Plastigage will smear, resulting in inaccurate indication.

(7) Remove the bearing cap and determine amount of bearing-to-journal clearance by measuring the width of compressed Plastigage (Fig. 7). Refer to Engine Specifications for the proper clearance. **Plastigage should indicate the same clearance across the entire width of the insert. If the clearance varies, it may be caused by either a tapered journal, bent connecting rod or foreign material trapped between the insert and cap or rod.**

(8) If the correct clearance is indicated, replacement of the bearing inserts is not necessary. Remove the Plastigage from crankshaft journal and bearing insert. Proceed with installation.

(9) If bearing-to-journal clearance exceeds the specification, install a pair of 0.0254 mm (0.001 inch) undersize bearing inserts. All the odd size inserts must be on the bottom. The sizes of the service replacement bearing inserts are stamped on the backs of the inserts. Measure the clearance as described in the previous steps.

(10) The clearance is measured with a pair of 0.0254 mm (0.001 inch) undersize bearing inserts installed. This will determine if two 0.0254 mm (0.001 inch) undersize inserts or another combination is needed to provide the correct clearance (refer to Connecting Rod Bearing Fitting Chart).

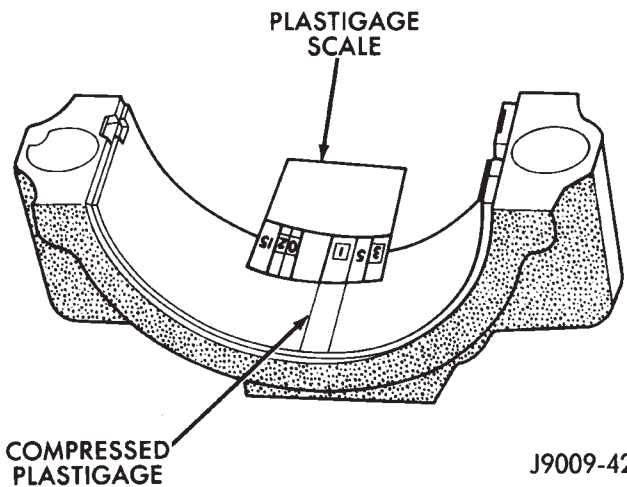

J9009-42

Fig. 7 Measuring Bearing Clearance with Plastigage

FOR EXAMPLE: If the initial clearance was 0.0762 mm (0.003 inch), 0.025 mm (0.001 inch) undersize inserts would reduce the clearance by 0.025 mm (0.001 inch). The clearance would be 0.002 inch and within specification. A 0.051 mm (0.002 inch) undersize insert would reduce the initial clearance an additional 0.013 mm (0.0005 inch). The clearance would then be 0.038 mm (0.0015 inch).

(11) Repeat the Plastigage measurement to verify your bearing selection prior to final assembly.

(12) Once you have selected the proper insert, install the insert and cap. Tighten the connecting rod bolts to 45 N·m (33 ft. lbs.) torque.

CONNECTING ROD BEARING FITTING CHART

Crankshaft Journal		Corresponding Connecting Rod Bearing Insert	
Color Code	Diameter	Upper Insert Size	Lower Insert Size
Yellow	53.2257-53.2079 mm (2.0955-2.0948 in.)	Yellow - Standard	Yellow - Standard
Orange	53.2079-53.1901 mm (2.0948-2.0941 in.) 0.0178 mm (0.0007 in.) Undersize	Yellow - Standard	Blue - Undersize 0.025 mm (0.001 in.)
Blue	53.1901-53.1724 mm (2.0941-2.0934 in.) 0.0356 mm (0.0014 in.) Undersize	Blue - Undersize 0.025 mm (0.001 in.)	Blue - Undersize 0.025 mm (0.001 in.)
Red	52.9717-52.9539 mm (2.0855-2.0848 in.) 0.254 mm (0.010 in.) Undersize	Red - Undersize 0.254 mm (0.010 in.)	Red - Undersize 0.254 mm (0.010 in.)

SIDE CLEARANCE MEASUREMENT

Slide snug-fitting feeler gauge between the connecting rod and crankshaft journal flange. Refer to Engine Specifications for the proper clearance. Replace the connecting rod if the side clearance is not within specification.

PISTON FITTING

MICROMETER METHOD

(1) Measure the inside diameter of the cylinder bore at a point 58.725 mm (2-5/16 inches) below top of bore.

(2) Measure outside diameter of the piston. Because pistons are cam ground, measure at right angle to piston pin at center line of pin (Fig. 8).

The difference between cylinder bore diameter and piston diameter is piston-to-bore clearance.

GROOVE HEIGHT

A	2.0193-2.0447 mm (0.0795-0.0805 in)
B	4.7752-4.8133 mm (0.1880-0.1895 in)

GROOVE DIAMETER

D - E	87.78-87.90 mm (3.456-3.461 in)
F	87.50-87.75 mm (3.445-3.455 in)

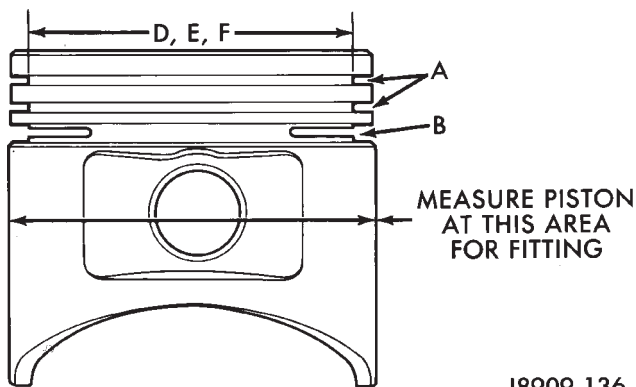

J8909-136

Fig. 8 Piston Dimensions

FEELER GAUGE METHOD

- (1) Remove the rings from the piston.
- (2) Insert a long 0.025 mm (0.001 inch) feeler gauge into the cylinder bore.
- (3) Insert the piston, top first, into cylinder bore alongside the feeler gauge. With entire piston inserted into cylinder bore, the piston should not bind against feeler gauge.
- (4) Repeat steps with a long 0.051 mm (0.002 inch) feeler gauge. The piston should bind.
- (5) If the piston binds on 0.025 mm (0.001 inch) feeler gauge, the piston is too large or cylinder bore is too small. If the piston does not bind on 0.051 mm (0.002 inch) feeler gauge, the piston is too small for cylinder bore. Pistons up to 0.102 mm (0.004 inch)

undersize may be enlarged by knurling or shot-peening. Replace pistons that are 0.102 mm (0.004 inch) or more undersize.

PISTON PIN

REMOVAL

Piston pins are press-fitted into the connecting rods and require no locking device.

(1) Position the piston and connecting rod assembly on an arbor press.

(2) Apply force to a piloted driver and press the pin completely out of the connecting rod and piston assembly (Fig. 9). Note position of the pin through the gauge window of removal support tool.

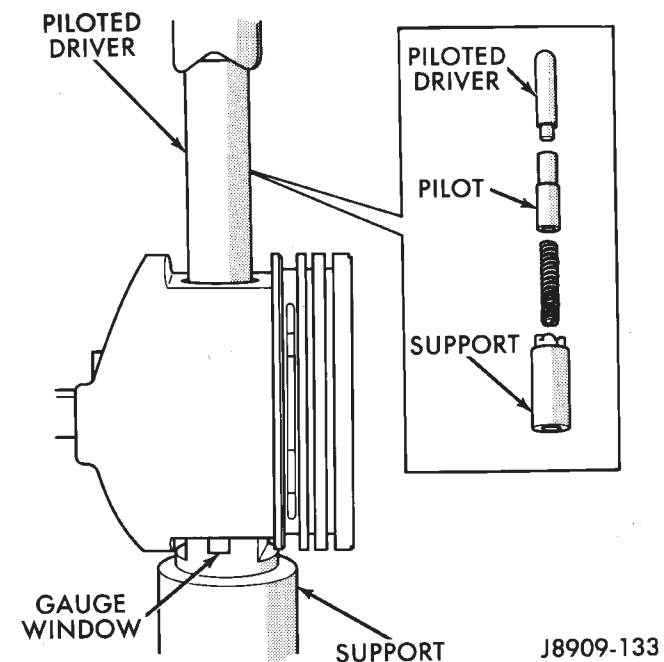

J8909-133

Fig. 9 Piston Pin Removal/Installation

INSPECTION

(1) Inspect the piston pin and pin bore in the connecting rod for nicks and burrs. Remove as necessary. Never reuse a piston pin after it has been installed in and removed from a connecting rod.

(2) With the pin removed from the piston and connecting rod, clean and dry piston pin bores and the replacement piston pin.

(3) Position the piston so that the pin bore is in vertical position. Insert the pin in bore. At room temperature, the replacement pin should slide completely through the pin bore in piston by force of gravity.

(4) Replace piston if pin jams in the pin bore.

INSTALLATION

(1) Insert the piston pin pilot through the piston and connecting rod pin bores. Ensure that the arrow on the piston crown is pointing up (Fig. 10).

(2) Position the pin pilot, piston and connecting rod on a support with the squirt hole of the connecting rod to the left-hand side (Fig. 10).

(3) Insert piston pin through the upper piston pin bore and into the connecting rod pin bore.

(4) Position the piloted driver inside the piston pin (Fig. 9).

(5) Using an arbor press, press the piston pin through the connecting rod and piston bores until pin pilot indexes with mark on the support. The piston pin requires a 8 900 N (2,000 pounds) press-fit. If little effort is required to install piston pin in a connecting rod, or if the rod moves laterally on the pin, the connecting rod must be replaced.

(6) Remove the piston and connecting rod assembly from the press. The pin should be centered in the connecting rod (± 0.792 mm or ± 0.0312 inch) and float in the piston pin bore.

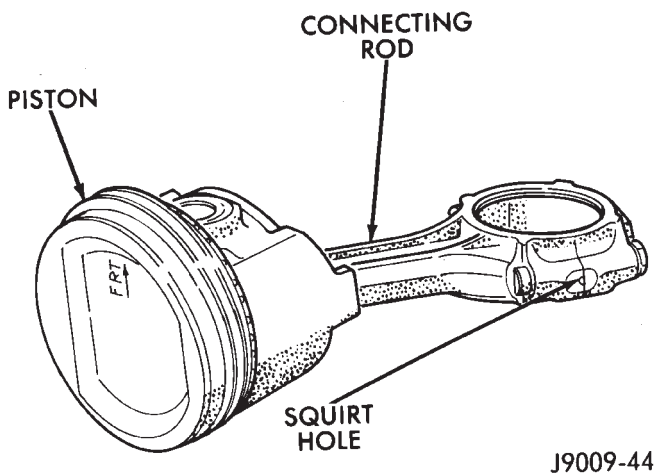

J9009-44

Fig. 10 Correct Alignment—Piston and Connecting Rod

PISTON RING FITTING

(1) Carefully clean the carbon from all ring grooves. Oil drain openings in the oil ring groove and pin boss must be clear. DO NOT remove metal from the grooves or lands. This will change ring-to-groove clearances and will damage the ring-to-land seating.

(2) Be sure the piston ring grooves are free of nicks and burrs.

(3) Measure the ring side clearance with a feeler gauge fitted snugly between the ring land and ring (Fig. 11). Rotate the ring in the groove. It must move freely around circumference of the groove.

(4) Place ring in the cylinder bore and push down with inverted piston to position near lower end of the ring travel. Measure ring gap with a feeler gauge fitting snugly between ring ends (Fig. 12). The correct compression ring end gap is 0.25-0.51 mm (0.010-0.020 inch). The correct oil control ring end gap is 0.381-1.397 mm (0.015-0.055 inch).

(5) Install the oil control rings according to instructions in the package. It is not necessary to use a

	<u>Millimeters</u>	<u>Inches</u>
No. 1 Compression	0.025-0.081 (0.043 Preferred)	0.001-0.0032 (0.0017 Preferred)
No. 2 Compression	0.025-0.081 (0.043 Preferred)	0.001-0.0032 (0.0017 Preferred)
Oil Control	0.025-0.241 (0.08 Preferred)	0.001-0.0095 (0.003 Preferred)

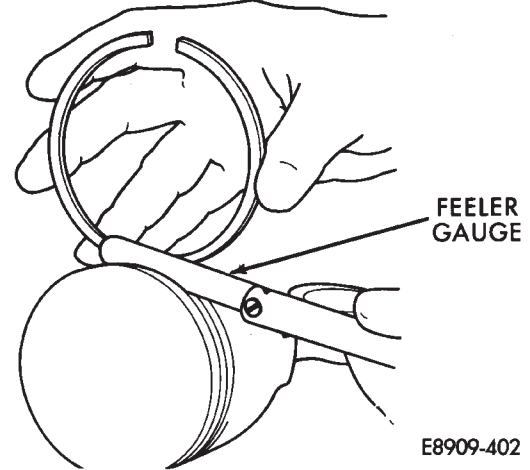

Fig. 11 Ring Side Clearance Measurement

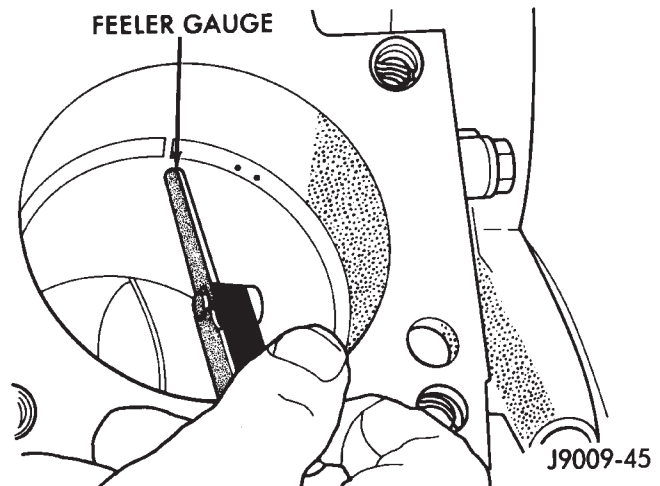

Fig. 12 Ring Gap Measurement

tool to install the upper and lower rails. Insert oil rail spacer first, then side rails.

(6) The two compression rings are different and cannot be interchanged. The top ring (Fig. 13) is a moly ring (the scraping edge is gray in color). The second ring (Fig. 14) is a black cast iron ring (the scraping edge is black in color when new). The compression rings may also be identified by 1 or 2 dots on the top surface of the ring (Figs. 13 and 14).

(7) The second compression ring (black cast iron) has a chamfer on the BOTTOM of the inside edge (Fig. 15). This ring may also have 2 dots located on the top surface.

(8) Using a ring installer, install the second compression ring with the chamfer facing down (Fig. 16). The two dots will be facing up.

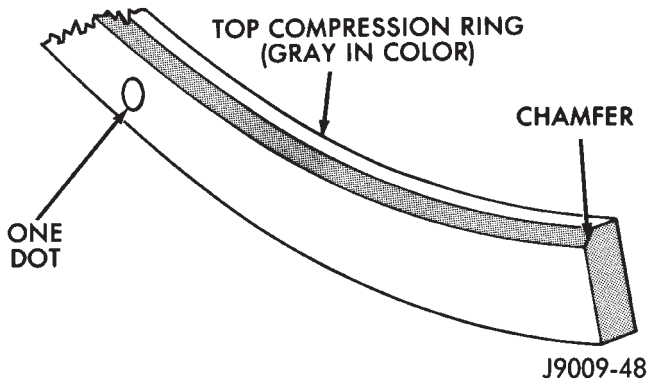

Fig. 13 Top Compression Ring Identification

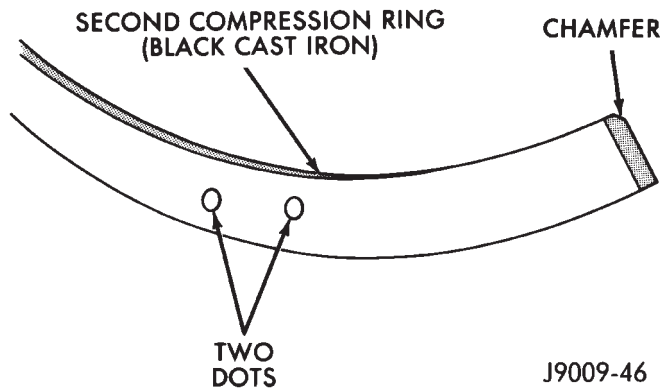

Fig. 14 Second Compression Ring Identification

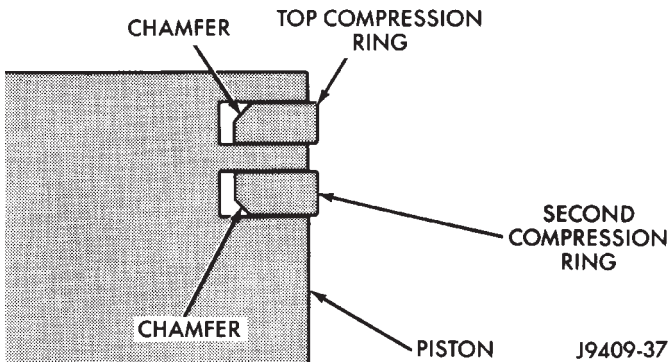

Fig. 15 Compression Ring Chamfer Location

(9) The top compression ring (the scraping edge is gray in color) has a chamfer on the TOP of the inside edge (Fig. 15). This ring may also have 1 dot located on the top surface.

(10) Using a ring installer, install the top ring with the chamfer facing up (Fig. 16). The dot will be facing up.

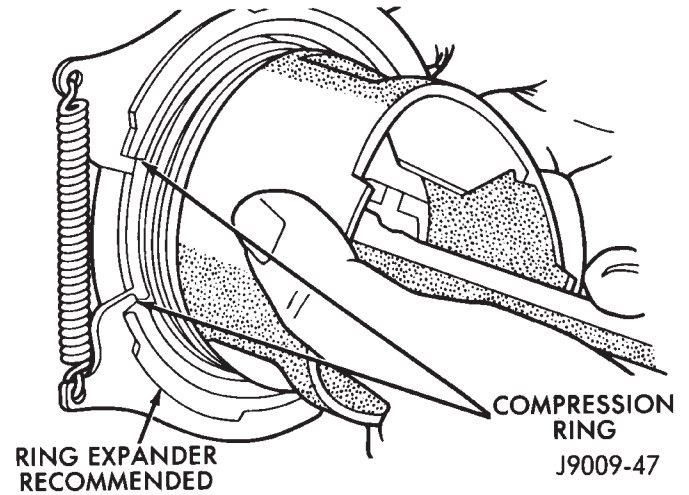

Fig. 16 Compression Ring Installation

(11) Position the gaps on the piston (Fig. 17):

- Oil spacer - Gap on center line of piston pin bore.
- Oil rails - Gap 180° apart on centerline of piston skirt.
- No. 2 Compression ring - Gap 180° from top oil rail gap.
- No. 1 Compression ring - Gap 180° from No. 2 compression ring gap.

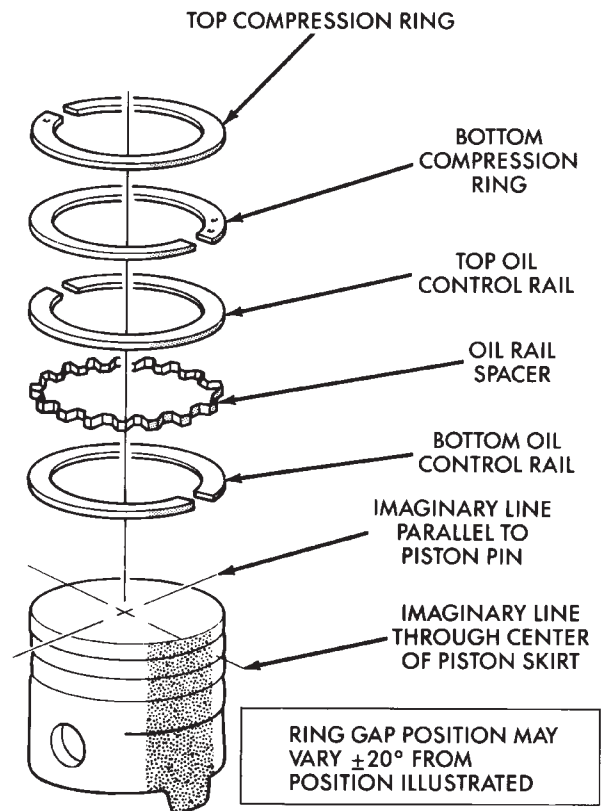

Fig. 17 Ring Gap Position

CLEANING

Clean the cylinder bores thoroughly. Apply a light film of clean engine oil to the bores with a clean lint-free cloth.

INSTALLATION

(1) Install the piston rings on the pistons if removed.

(2) Lubricate the piston and rings with clean engine oil.

CAUTION: Ensure that connecting rod bolts do not scratch the crankshaft journals or cylinder walls. Short pieces of rubber hose slipped over the connecting rod bolts will provide protection during installation.

(3) Use a piston ring compressor to install the connecting rod and piston assemblies through the top of the cylinder bores (Fig. 18).

(4) Ensure the arrow on the piston top points to the front of the engine (Fig. 18).

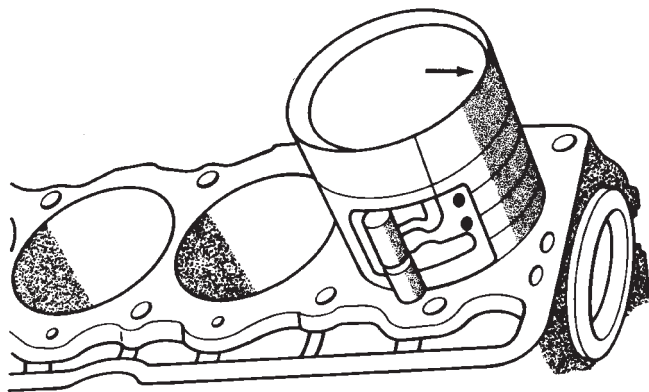

J9009-41

Fig. 18 Rod and Piston Assembly Installation

(5) Raise the vehicle.

Each bearing insert is fitted to its respective journal to obtain the specified clearance between the bearing and the journal. In production, the select fit is obtained by using various-sized, color-coded bearing inserts as listed in the Connecting Rod Bearing Fitting Chart. The color code appears on the edge of the bearing insert. The size is not stamped on inserts used for production of engines.

The rod journal is identified during the engine production by a color-coded paint mark on the adjacent cheek or counterweight toward the flange (rear) end of the crankshaft. The color codes used to indicate journal sizes are listed in the Connecting Rod Bearing Fitting Chart.

When required, upper and lower bearing inserts of different sizes may be used as a pair (refer to Connecting Rod Bearing Fitting Chart). A standard size

insert is sometimes used in combination with a 0.025 mm (0.001 inch) undersize insert to reduce clearance 0.013 mm (0.0005 inch).

CAUTION: DO NOT intermix bearing caps. Each connecting rod and bearing cap are stamped with the cylinder number. The stamp is located on a machined surface adjacent to the oil squirt hole that faces the camshaft side of the cylinder block.

(6) Install the connecting rod bearing caps and inserts in the same positions as removed.

CAUTION: Verify that the oil squirt holes in the rods face the camshaft and that the arrows on the pistons face the front of the engine.

(7) Install the oil pan and gaskets as outlined in the installation procedure.

(8) Lower the vehicle.

(9) Install the engine cylinder head, push rods, rocker arms, bridges, pivots and engine cylinder head cover.

(10) Fill the crankcase with engine oil.

CRANKSHAFT MAIN BEARINGS**REMOVAL**

(1) Disconnect negative cable from battery.

(2) Remove the spark plugs.

(3) Raise the vehicle.

(4) Remove the oil pan and oil pump.

(5) Remove only one main bearing cap and lower insert at a time (Fig. 1).

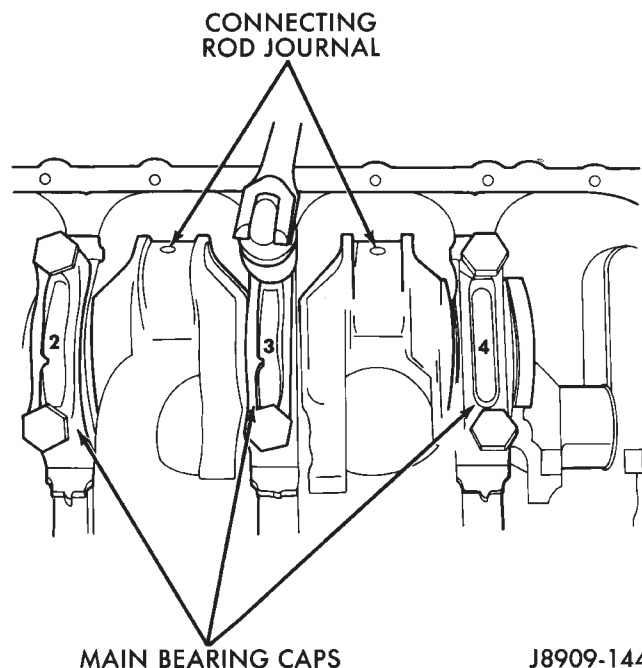

J8909-144

Fig. 1 Removing Main Bearing Caps and Lower Inserts

- (6) Remove the lower insert from the bearing cap.
- (7) Remove the upper insert by LOOSENING (DO NOT REMOVE) all of the other bearing caps. Now insert a small cotter pin tool in the crankshaft journal oil hole. Bend the cotter pin as illustrated to fabricate the tool (Fig. 2). With the cotter pin tool in place, rotate the crankshaft so that the upper bearing insert will rotate in the direction of its locking tab. Because there is no hole in the No.3 main journal, use a tongue depressor or similar soft-faced tool to remove the bearing insert (Fig. 2). After moving the insert approximately 25 mm (1 inch), it can be removed by applying pressure under the tab.
- (8) Using the same procedure described above, remove the remaining bearing inserts one at a time for inspection.

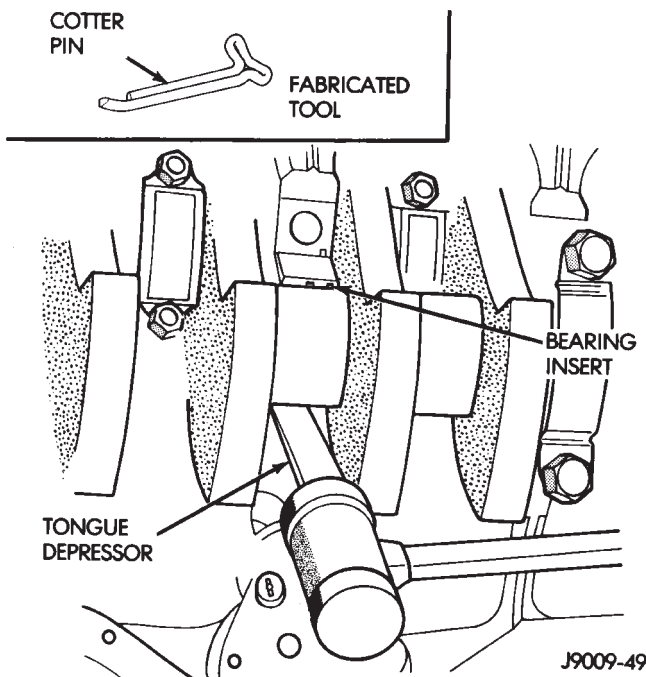

Fig. 2 Removing Upper Inserts

INSPECTION

Wipe the inserts clean and inspect for abnormal wear patterns and for metal or other foreign material imbedded in the lining. Normal main bearing insert wear patterns are illustrated (Fig. 3).

If any of the crankshaft journals are scored, remove the engine for crankshaft repair.

Inspect the back of the inserts for fractures, scrapings or irregular wear patterns.

Inspect the upper insert locking tabs for damage.
 Replace all damaged or worn bearing inserts.

FITTING (CRANKSHAFT INSTALLED)

The main bearing caps, numbered (front to rear) from 1 through 5 have an arrow to indicate the forward position. The upper main bearing inserts are grooved to provide oil channels while the lower inserts are smooth.

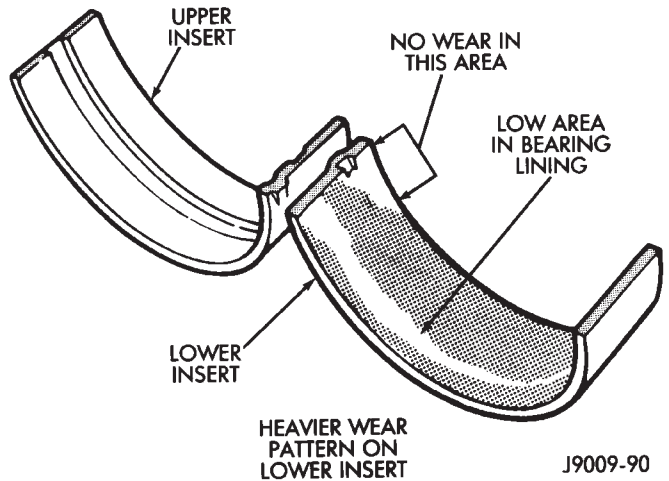

Fig. 3 Main Bearing Wear Patterns

Each bearing insert pair is selectively fitted to its respective journal to obtain the specified operating clearance. In production, the select fit is obtained by using various-sized color-coded bearing insert pairs as listed in the Main Bearing Fitting Chart. The bearing color code appears on the edge of the insert. **The size is not stamped on bearing inserts used for engine production.**

The main bearing journal size (diameter) is identified by a color-coded paint mark on the adjacent cheek. The rear main journal, is identified by a color-coded paint mark on the crankshaft rear flange.

When required, upper and lower bearing inserts of different sizes may be used as a pair. A standard size insert is sometimes used in combination with a 0.025 mm (0.001 inch) undersize insert to reduce the clearance by 0.013 mm (0.0005 inch). **Never use a pair of bearing inserts with greater than a 0.025 mm (0.001 inch) difference in size (Fig. 4).**

Insert	Correct	Incorrect
Upper	Standard	Standard
Lower	0.025 mm (0.001 in.) Undersize	0.051 mm (0.002 in.) Undersize

J9109-179

Fig. 4 Bearing Insert Pairs

When replacing inserts, the odd size inserts must be either all on the top (in cylinder block) or all on the bottom (in main bearing cap).

Once the bearings have been properly fitted, proceed to Crankshaft Main Bearing—Installation.

BEARING-TO-JOURNAL CLEARANCE (CRANKSHAFT INSTALLED)

When using Plastigage, check only one bearing clearance at a time.

Install the grooved main bearings into the cylinder block and the non-grooved bearings into the bearing caps.

Install the crankshaft into the upper bearings dry.

Place a strip of Plastigage across full width of the crankshaft journal to be checked.

Install the bearing cap and tighten the bolts to 108 N·m (80 ft. lbs.) torque.

DO NOT rotate the crankshaft. This will cause the Plastigage to shift, resulting in an inaccurate reading. Plastigage must not be permitted to crumble. If brittle, obtain fresh stock.

Remove the bearing cap. Determine the amount of clearance by measuring the width of the compressed Plastigage with the scale on the Plastigage envelope (Fig. 5). Refer to Engine Specifications for the proper clearance.

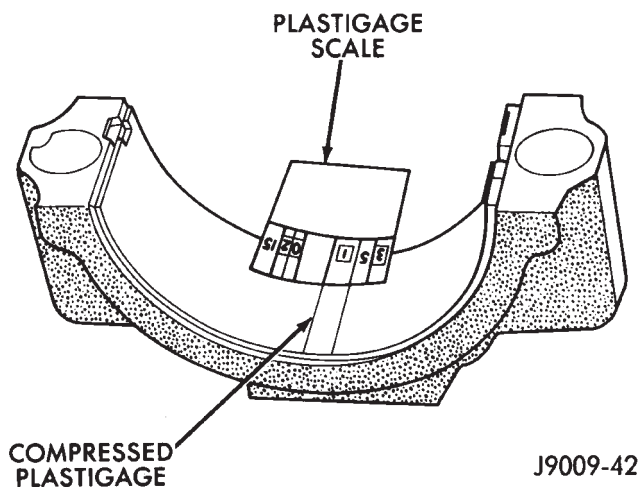

Fig. 5 Measuring Bearing Clearance with Plastigage

Plastigage should indicate the same clearance across the entire width of the insert. If clearance varies, it may indicate a tapered journal or foreign material trapped behind the insert.

If the specified clearance is indicated and there are no abnormal wear patterns, replacement of the bearing inserts is not necessary. Remove the Plastigage from the crankshaft journal and bearing insert. Proceed to Crankshaft Main Bearing—Installation.

If the clearance exceeds specification, install a pair of 0.025 mm (0.001 inch) undersize bearing inserts and measure the clearance as described in the previous steps.

The clearance indicated with the 0.025 mm (0.001 inch) undersize insert pair installed will determine if this insert size or some other combination will provide the specified clearance.

FOR EXAMPLE: If the clearance was 0.0762 mm (0.003 inch) originally, a pair of 0.0254 mm (0.001 inch) undersize inserts would reduce the clearance by 0.0254 mm (0.001 inch). The clearance would then be 0.0508 mm (0.002 inch) and within the specification. A 0.051 mm (0.002 inch) undersize bearing insert and a 0.0254 mm (0.001 inch) undersize insert would reduce the original clearance an additional 0.0127 mm (0.0005 inch). The clearance would then be 0.0381 mm (0.0015 inch).

CAUTION: Never use a pair of inserts that differ more than one bearing size as a pair.

FOR EXAMPLE: DO NOT use a standard size upper insert and a 0.051 mm (0.002 inch) undersize lower insert.

If the clearance exceeds specification using a pair of 0.051 mm (0.002 inch) undersize bearing inserts, measure crankshaft journal diameter with a micrometer. If the journal diameter is correct, the crankshaft bore in the cylinder block may be misaligned, which requires cylinder block replacement or machining to true bore.

If journals 1 through 5 diameters are less than 63.4517 mm (2.4981 inches), replace crankshaft or grind crankshaft down to accept the appropriate undersize bearing inserts.

Once the proper clearances have been obtained, proceed to Crankshaft Main Bearing—Installation.

MAIN BEARING JOURNAL DIAMETER (CRANKSHAFT REMOVED)

Remove the crankshaft from the cylinder block (refer to Cylinder Block - Disassemble).

Clean the oil off the main bearing journal.

Determine the maximum diameter of the journal with a micrometer. Measure at two locations 90° apart at each end of the journal.

The maximum allowable taper and out of round is 0.013 mm (0.0005 inch). Compare the measured diameter with the journal diameter specification (Main Bearing Fitting Chart). Select inserts required to obtain the specified bearing-to-journal clearance.

Once the proper clearances have been obtained, proceed to Crankshaft Main Bearing—Installation.

INSTALLATION

(1) Lubricate the bearing surface of each insert with engine oil.

(2) Loosen all the main bearing caps. Install the main bearing upper inserts.

(3) Install the lower bearing inserts into the main bearing caps.

(4) Install the main bearing cap(s) and lower insert(s).

(5) Clean the rear main bearing cap (No.5) mating surfaces.

MAIN BEARING FITTING CHART

Crankshaft Journals #1 - #4		Corresponding Crankshaft Bearing Insert	
Color Code	Diameter	Upper Insert Size	Lower Insert Size
Yellow	63.5025-63.4898 mm (2.5001-2.4996 in.)	Yellow - Standard	Yellow - Standard
Orange	63.4898-63.4771 mm (2.4996-2.4991 in.) 0.0127 mm (0.0005 in.) Undersize	Blue - Undersize 0.025 mm (0.001 in.)	Yellow - Standard
Blue	63.4771-63.4644 mm (2.4991-2.4986 in.) 0.0254 mm (0.001 in.) Undersize	Blue - Undersize 0.025 mm (0.001 in.)	Blue - Undersize 0.025 mm (0.001 in.)
Green	63.4644-63.4517 mm (2.4986-2.4981 in.) 0.0381 mm (0.0015 in.) Undersize	Blue - Undersize 0.025 mm (0.001 in.)	Green - Undersize 0.051 mm (0.002 in.)
Red	63.2485-63.2358 mm (2.4901-2.4896 in.) 0.254 mm (0.010 in.) Undersize	Red - Undersize 0.254 mm (0.010 in.)	Red - Undersize 0.254 mm (0.010 in.)

Crankshaft Journals #5 Only		Corresponding Crankshaft Bearing Insert	
Color Code	Diameter	Upper Insert Size	Lower Insert Size
Yellow	63.4873-63.4746 mm (2.4995-2.4990 in.)	Yellow - Standard	Yellow - Standard
Orange	63.4746-63.4619 mm (2.4990-2.4985 in.) 0.0127 mm (0.0005 in.) Undersize	Blue - Undersize 0.025 mm (0.001 in.)	Yellow - Standard
Blue	63.4619-63.4492 mm (2.4985-2.4980 in.) 0.0254 mm (0.001 in.) Undersize	Blue - Undersize 0.025 mm (0.001 in.)	Blue - Undersize 0.025 mm (0.001 in.)
Green	63.4492-63.4365 mm (2.4980-2.4975 in.) 0.0381 mm (0.0015 in.) Undersize	Blue - Undersize 0.025 mm (0.001 in.)	Green - Undersize 0.051 mm (0.002 in.)
Red	63.2333-63.2206 mm (2.4895-2.4890 in.) 0.254 mm (0.010 in.) Undersize	Red - Undersize 0.254 mm (0.010 in.)	Red - Undersize 0.254 mm (0.010 in.)

(6) Apply Loctite 515, or equivalent on the rear bearing cap (Fig. 6). The bead should be 3 mm (0.125 in) thick. DO NOT apply Loctite 515, or equivalent to the lip of the seal.

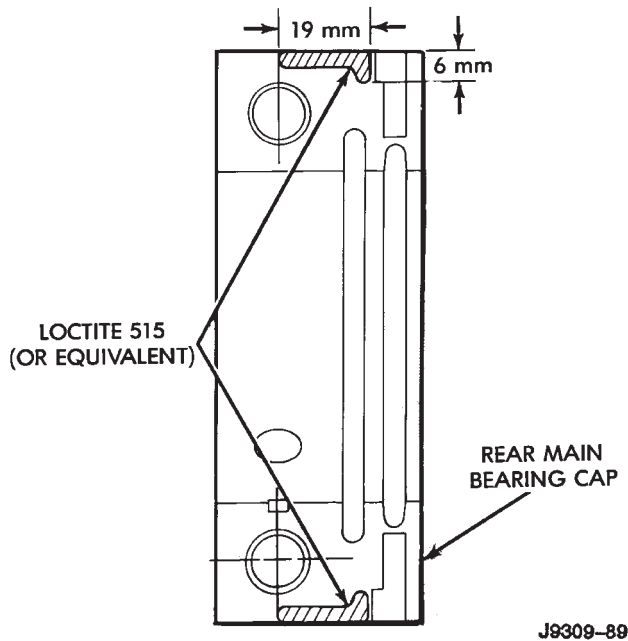

Fig. 6 Location of Loctite 515 (or equivalent)

(7) Install the rear main bearing cap. DO NOT strike the cap more than twice for proper engagement.

(8) Tighten the bolts of caps 1, 3, 4 and 5 to 54 N·m (40 ft. lbs.) torque. Now tighten these bolts to 95 N·m (70 ft. lbs.) torque. Finally, tighten these bolts to 108 N·m (80 ft. lbs.) torque.

(9) Push the crankshaft forward and backward. Load the crankshaft front or rear and tighten cap bolt No.2 to 54 N·m (40 ft. lbs.) torque. Then tighten to 95 N·m (70 ft. lbs.) torque and finally tighten to 108 N·m (80 ft. lbs.) torque.

(10) Rotate the crankshaft after tightening each main bearing cap to ensure the crankshaft rotates freely.

(11) Check crankshaft end play. Crankshaft end play is controlled by the thrust bearing which is flange and installed at the No.2 main bearing position.

(a) Attach a magnetic base dial indicator to the cylinder block at either the front or rear of the engine.

(b) Position the dial indicator rod so that it is parallel to the center line of the crankshaft.

(c) Pry the crankshaft forward, position the dial indicator to zero.

(d) Pry the crankshaft forward and backward. Note the dial indicator readings. End play is the difference between the high and low measurements (Fig. 7). Correct end play is 0.038-0.165 mm

(0.0015-0.0065 inch). The desired specifications are 0.051-0.064 mm (0.002-0.0025 inch).

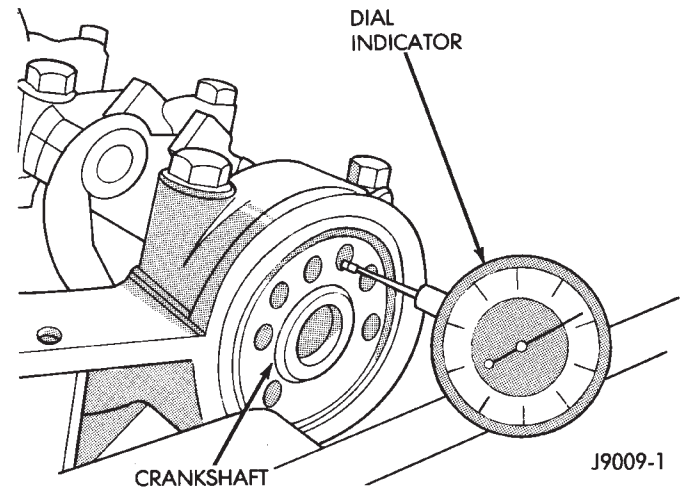

Fig. 7 Crankshaft End Play Measurement

(e) If end play is not within specification, inspect crankshaft thrust faces for wear. If no wear is apparent, replace the thrust bearing and measure end play. If end play is still not within specification, replace the crankshaft.

If the crankshaft was removed, install the crankshaft into the cylinder block (refer to Cylinder Block - Assemble).

(12) Install the oil pan.

(13) Install the drain plug. Tighten the plug to 34 N·m (25 ft. lbs.) torque.

(14) Lower the vehicle.

(15) Install the spark plugs. Tighten the plugs to 37 N·m (27 ft. lbs.) torque.

(16) Fill the oil pan with engine oil to the full mark on the dipstick level.

(17) Connect negative cable to battery.

REAR MAIN OIL SEALS

REMOVAL

(1) Remove the flywheel or converter drive plate. Discard the old bolts.

(2) Pry out the seal from around the crankshaft flange (Fig. 8).

INSTALLATION

(1) Coat the outer lip of the replacement rear main bearing seal with engine oil.

(2) Carefully position the seal into place. Use rear main Seal Installer Tool 6271 to install the seal flush with the cylinder block.

CAUTION: The felt lip must be located inside the flywheel mounting surface. If the lip is not positioned correctly the flywheel could tear the seal.

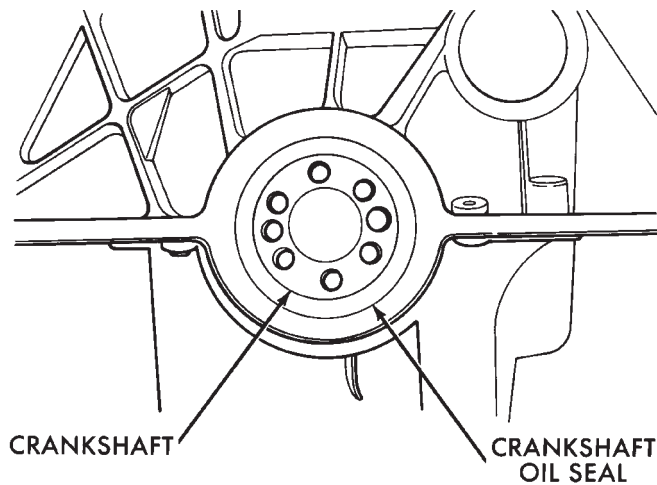

J8909-149

Fig. 8 Replacement of Rear Crankshaft Oil Seal

(3) Install the flywheel or converter drive plate. New bolts **MUST** be used when installing the flywheel or converter plate. Tighten the new bolts to 68 N·m (50 ft. lbs.) torque. Turn the bolts an additional 60°.

CYLINDER BLOCK

Remove the Engine Assembly from the vehicle.

DISASSEMBLY

Refer to the applicable sections for detailed instructions.

- (1) Drain the engine oil. Remove and discard the oil filter.
- (2) Remove the water pump from the cylinder block.
- (3) Remove the distributor from the cylinder block.
- (4) Remove the vibration damper.
- (5) Remove the timing case cover and lay the cover upside down.
- (6) Position a drift punch into the slot in the back of the cover and tap the old seal out.
- (7) Remove the timing chain bumper.
- (8) Remove the oil slinger from crankshaft.
- (9) Remove the camshaft retaining bolt and remove the sprockets and chain as an assembly.
- (10) Remove the camshaft.
- (11) Remove the oil pan and gasket.
- (12) Remove the timing chain tensioner.
- (13) Remove the front and rear oil galley plugs.
- (14) Remove the connecting rods and the pistons. Remove the connecting rod and piston assemblies through the top of the cylinder bores.
- (15) Remove the crankshaft.

CLEANING

Thoroughly clean the oil pan and engine block gasket surfaces.

Use compressed air to clean out:

- The galley at the oil filter adaptor hole, the filter bypass hole (Fig. 9).

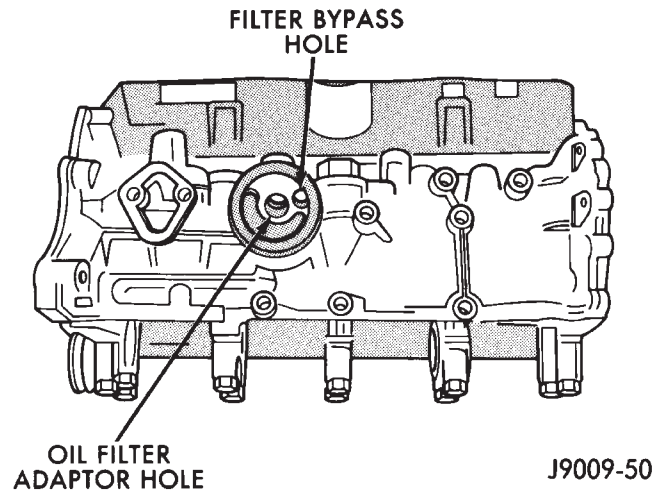

J9009-50

Fig. 9 Oil Filter Adaptor Hole

- The front and rear oil galley holes (Figs. 10 and 11).

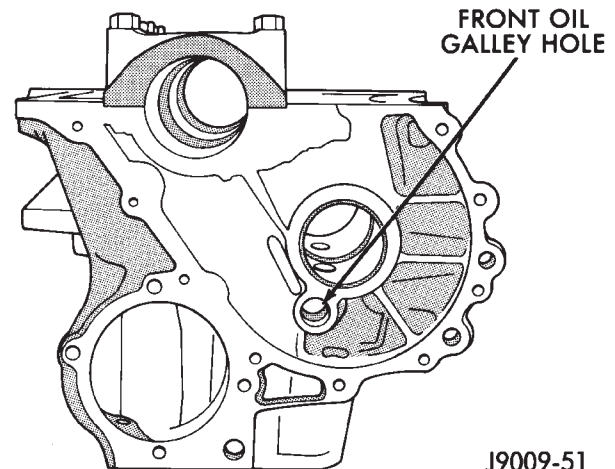

J9009-51

Fig. 10 Front Oil Galley Hole

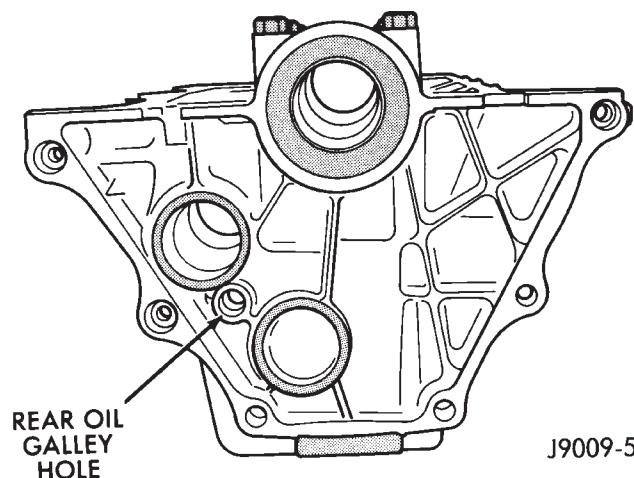

J9009-52

Fig. 11 Rear Oil Galley Hole

- The feed holes for the crankshaft main bearings.

Once the block has been completely cleaned, apply Loctite PST pipe sealant with Teflon 592 to the threads of the front and rear oil galley plugs. Tighten the plugs to 41 N·m (30 ft. lbs.) torque.

INSPECTION—CYLINDER BORE

(1) Use a bore gauge to measure each cylinder bore diameter (Fig. 12). If a bore gauge is not available, use an inside micrometer.

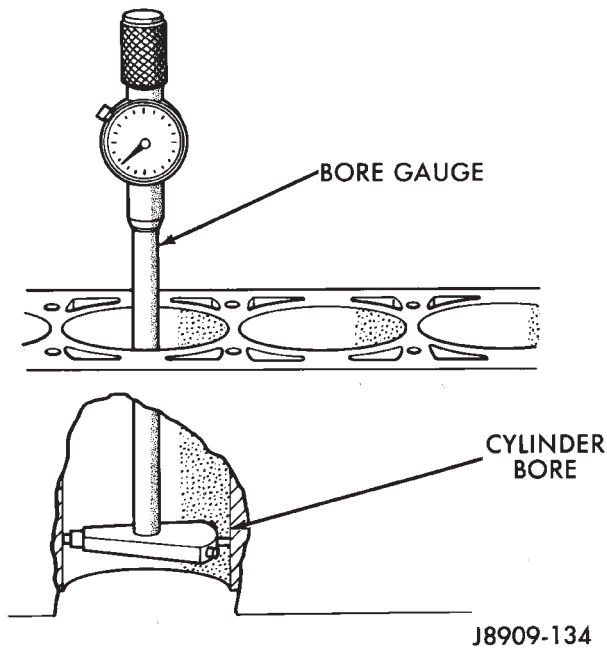

Fig. 12 Cylinder Bore Measurement

(2) Measure the cylinder bore diameter crosswise to the cylinder block near the top of the bore. Repeat the measurement near the bottom of the bore.

(3) Determine taper by subtracting the smaller diameter from the larger diameter.

(4) Rotate measuring device 120° and repeat steps above. Finally, rotate the device another 120° and repeat measurements.

(5) Determine out-of-roundness by comparing the difference between each 120° measurement.

(6) If cylinder bore taper does not exceed 0.025 mm (0.001 inch) and out-of-roundness does not exceed 0.025 mm (0.001 inch), the cylinder bore can be honed. If the cylinder bore taper or out-of-round condition exceeds these maximum limits, the cylinder must be bored and then honed to accept an oversize piston. A slight amount of taper always exists in the cylinder bore after the engine has been in use for a period of time.

HONING—CYLINDER BORE

The honing operation should be closely coordinated with the fitting of pistons and rings. This will ensure specified clearances are maintained.

Refer to Standard Service Procedures in the beginning of this Group for the proper honing of cylinder bores.

ASSEMBLY

Refer to the applicable sections for detailed instructions.

- (1) Install the crankshaft.
- (2) Install the connecting rods and the pistons through the top of the cylinder bores.
- (3) Install the front and rear oil galley plugs.
- (4) Install the timing chain tensioner.
- (5) Install the camshaft.
- (6) Install the sprockets and chain as an assembly.
- (7) Install the oil slinger to the crankshaft.
- (8) Install the timing chain bumper.
- (9) Install the timing case cover seal.
- (10) Install the timing case cover.
- (11) Install the oil pan gasket and oil pan.
- (12) Install the vibration damper.
- (13) Install the water pump. Tighten the mounting bolts to 31 N·m (270 in. lbs.) torque.
- (14) Remove the distributor from the cylinder block.
- (15) Lubricate the oil filter seal with clean engine oil. Tighten oil filter to 18 N·m (13 ft. lbs.) torque.
- (16) Install the engine into the vehicle.
- (17) Fill the engine with clean lubrication oil (refer to Group 0, Lubrication and Maintenance).
- (18) Fill the cooling system (refer to Group 7, Cooling System for the proper procedures).

SPECIFICATIONS

ENGINE SPECIFICATIONS

Camshaft

Hydraulic Tappet Clearance	Zero Lash
Bearing Clearance.....	0.025 - 0.076 mm (0.001 - 0.003 in)
Bearing Journal Diameter	
No.1.....	51.54 - 51.56 mm (2.029 - 2.030 in)
No.2.....	51.28 - 51.31 mm (2.019 - 2.020 in)
No.3.....	51.03 - 51.05 mm (2.009 - 2.010 in)
No.4.....	50.78 - 50.80 mm (1.999 - 2.000 in)
Base Circle Runout.....	0.03 mm - max. (0.001 in - max.)
Camshaft Lobe Lift	6.731 mm (0.265 in)
Valve Lift	10.77 mm (0.424 in)
Intake Valve Timing	
Opens	16°BTDC
Closes.....	74°ABDC
Exhaust Valve Timing	
Opens.....	60°BBDC
Closes.....	30°ATDC
Valve Overlap	46°
Intake Duration	270°
Exhaust Duration.....	270°

Crankshaft

End Play.....	0.038 - 0.165 mm (0.0015 - 0.0065 in)
Main Bearing Journal Dia	63.489 - 63.502 mm (2.4996 - 2.5001 in)
Main Bearing Journal Width	
No.1.....	27.58 - 27.89 mm (1.086 - 1.098 in)
No.2.....	32.28 - 32.33 mm (1.271 - 1.273 in)
No.3-4-5	30.02 - 30.18 mm (1.182 - 1.188 in)
Main Bearing Clearance	0.03 - 0.06 mm (0.001 - 0.0025 in)
Preferred	0.051 mm (0.002 in)
Connecting Rod Journal Dia.....	53.17 - 53.23 mm (2.0934 - 2.0955 in)
Connecting Rod Journal Width.....	27.18 - 27.33 mm (1.070 - 1.076 in)
Out-of-Round (Max. All Journals)	0.013 mm (0.0005 in)
Taper (Max. - All Journals).....	0.013 mm (0.0005 in)

Cylinder Block

Deck Height.....	236.73 mm (9.320 in)
Deck Clearance	0.000 mm (0.000 in)
Cylinder Bore Diameter	
Standard	98.45 - 98.48 mm (3.8759 - 3.8775 in)
Taper (Max.)	0.025 mm (0.001 in)
Out-of-Round (Max.)	0.025 mm (0.001 in)
Tappet Bore Diameter	23.000 - 23.025 mm (0.9055 - 0.9065 in)
Flatness	0.03 mm per 25 mm (0.001 in per 1 in)
	0.05 mm per 152 mm (0.002 in per 6 in)
	0.20 mm - max. for total length (0.008 in - max. for total length)
Main Bearing Bore Dia	68.3514 - 68.3768 mm (2.691 - 2.692 in)

Connecting Rods

Total Weight (Less Bearing).....	657 - 665 grams (23.17 - 23.45 oz)
Length (Center-to-Center).....	155.52 - 155.62 mm (6.123 - 6.127 in)
Piston Pin Bore Diameter.....	23.59 - 23.62 mm (0.9288 - 0.9298 in)
Bore (Less Bearings)	56.08 - 56.09 mm (2.2080 - 2.2085 in)
Bearing Clearance.....	0.025 - 0.076 mm (0.001 - 0.003 in)
Preferred	0.044 - 0.050 mm (0.0015 - 0.0020 in)
Side Clearance	0.25 - 0.48 mm (0.010 - 0.019 in)
Twist (Max.).....	0.001 mm per mm (0.001 in per in)
Bend (Max.).....	0.001 mm per mm (0.001 in per in)

Cylinder Compression Pressure

Ratio.....	9.1:1
Pressure Range.....	827 - 1 034 kPa (120 - 150 psi)
Max. Variation Between Cylinders	206 kPa (30 psi)

ENGINE SPECIFICATIONS (CONT.)

Cylinder Head

Combustion Chamber	49.9 - 52.9 cc (3.04 - 3.23 cu. in.)
Valve Guide I.D. (Integral)	7.95 - 7.97 mm (0.313 - 0.314 in)
Valve Stem-to-Guide Clearance	0.025 - 0.076 mm (0.001 - 0.003 in)
Intake Valve Seat Angle	44.5°
Exhaust Valve Seat Angle	44.5°
Valve Seat Width	1.02 - 1.52 mm (0.040 - 0.060 in)
Valve Seat Runout	0.064 mm (0.0025 in)
Flatness	0.03 mm per 25 mm (0.001 in per 1 in) 0.05 mm per 152 mm (0.002 in per 6 in) 0.20 mm - max. for total length (0.008 in - max. for total length)

Rocker Arms, Push Rods & Tappets

Rocker Arm Ratio	1.6:1
Push Rod Length	241.300 - 241.808 mm (9.500 - 9.520 in)
Push Rod Diameter	7.92 - 8.00 mm (0.312 - 0.315 in)
Hydraulic Tappet Diameter	22.962 - 22.974 mm (0.904 - 0.9045 in)
Tappet-to-Bore Clearance	0.025 - 0.063 mm (0.001 - 0.0025 in)

Valves

Length (Tip - to - Gauge Dimension Line)	
Intake	124.435 - 125.070 mm (4.899 - 4.924 in)
Exhaust	125.120 - 125.755 mm (4.927 - 4.952 in)
Valve Stem Diameter	7.899 - 7.925 mm (0.311 - 0.312 in)
Stem-to-Guide Clearance	0.025 - 0.076 mm (0.001 - 0.003 in)
Valve Head Diameter	
Intake	48.387 - 48.641 mm (1.905 - 1.915 in)
Exhaust	37.973 - 38.227 mm (1.495 - 1.505 in)
Valve Face Angle	
Intake	45°
Exhaust	45°
Tip Refinishing (Max. Allowable)	0.25 mm (0.010 in)

Valve Springs

Free Length (Approx.)	49.962 mm (1.967 in)
Spring Tension	
Valve Closed	360 - 396 N @ 41.656 mm (81 - 89 lbf @ 1.640 in)
Valve Open	845 - 934 N @ 30.886 mm (190 - 210 lbf @ 1.216 in)
Inside Diameter	24.08 - 24.59 mm (0.948 - 0.968 in)

Pistons

Weight (Less Pin)	563 - 567 grams (19.86 - 20.00 oz)
Piston Pin Bore (Centerline-to-Piston Top)	40.61 - 40.72 mm (1.599 - 1.603 in)
Piston-to-Bore Clearance	0.033 - 0.053 mm (0.0013 - 0.0021 in)
Preferred	0.033 - 0.038 mm (0.0013 - 0.0015 in)
Piston Ring Gap Clearance	
Compression Rings	0.25 - 0.51 mm (0.010 - 0.020 in)
Oil Control Steel Rails	0.381 - 1.397 mm (0.015 - 0.055 in)
Piston Ring Side Clearance	
Compression Rings	0.025 - 0.081 mm (0.001 - 0.0032 in)
Preferred	0.025 mm (0.001 in)
Oil Control Ring	0.025 - 0.216 mm (0.001 - 0.0085 in)
Preferred	0.08 mm (0.003 in)
Piston Ring Groove Height	
Compression Rings	2.019 - 2.045 mm (0.0795 - 0.0805 in)
Oil Control Ring	4.78 - 4.80 mm (0.1880 - 0.1895 in)
Piston Ring Groove Diameter	
Compression Rings	87.78 - 87.90 mm (3.456 - 3.461 in)
Oil Control Ring	87.50 - 87.75 mm (3.445 - 3.455 in)
Piston Pin Bore Diameter	23.647 - 23.655 mm (0.9310 - 0.9313 in)
Piston Pin Diameter	23.637 - 23.640 mm (0.9306 - 0.9307 in)
Piston-to-Pin Clearance	0.0076 - 0.0178 mm (0.0003 - 0.0007 in)
Preferred	0.015 mm - Loose (0.0006 in - Loose)
Piston-to-Pin Connecting Rod (Press Fit)	8.9 kN (2000 lb f)

ENGINE SPECIFICATIONS (CONT.)

Oil Pump

Gear-to-Body Clearance (Radial)	0.051 - 0.102 mm (0.002 - 0.004 in)
Preferred	0.051 mm (0.002 in)
Gear End Clearance	
Plastigage	0.051 - 0.152 mm (0.002 - 0.006 in)
Preferred	0.051 mm (0.002 in)
Feeler Gauge	0.1016 - 0.2032 mm (0.004 - 0.008 in)
Preferred	0.1778 mm (0.007 in)

Oil Pressure

Min. Pressure (600 rpm)	89.6 kPa (13 psi)
At Idle Speed (800 rpm)	172 - 241 kPa (25 - 35 psi)
At 1600 rpm & higher	255 - 517 kPa (37 - 75 psi)
Oil Pressure Relief	517 kPa (75 psi)

J9409-31

TORQUE SPECIFICATIONS

Description	Torque
A/C Compressor Bracket-to-Engine Bolts	34 N•m (25 ft. lbs.)
A/C Compressor Mounting Bolts	27 N•m (20 ft. lbs.)
A/C Low Pressure Service Valve Nut	38 N•m (28 ft. lbs.)
Block Heater Nut	1.8 N•m (16 in. lbs.)
Camshaft Sprocket Bolt	108 N•m (80 ft. lbs.)
Connecting Rod Nuts	45 N•m (33 ft. lbs.)
Converter Plate Bolts	68 N•m (50 ft. lbs.) +60° (+60°)
Cylinder Block Drain Plugs	41 N•m (30 ft. lbs.)
Cylinder Head Bolts	
(#1-10 & #12-14)	149 N•m (110 ft. lbs.)
(#11)	135 N•m (100 ft. lbs.)
Cylinder Head Cover Bolts	10 N•m (85 in. lbs.)
Drive Plate-to-Torque Converter Bolts	54 N•m (40 ft. lbs.)
Engine Shock Damper Stud Nuts	23 N•m (17 ft. lbs.)
Engine Mounts—Front	
Engine Support Bracket	
Bolts (XJ)	61 N•m (45 ft. lbs.)
Stud Nuts (XJ—Right Side)	46 N•m (34 ft. lbs.)
Bolts (YJ)	62 N•m (46 ft. lbs.)
Support Cushion	
Nuts (XJ—Right Side)	65 N•m (48 ft. lbs.)
Bolts/Nuts (XJ—Left Side)	41 N•m (30 ft. lbs.)
Bolts/Nuts (YJ)	52 N•m (38 ft. lbs.)
Support Cushion Bracket—(XJ)	
Bolts	54 N•m (40 ft. lbs.)
Stud Nuts	41 N•m (30 ft. lbs.)
Support Cushion Thru-Bolt	
XJ Vehicles	65 N•m (48 ft. lbs.)
YJ Vehicles	69 N•m (51 ft. lbs.)
Engine Mount—Rear	
Crossmember-to-Sill Bolts	
(XJ-Automatic)	41 N•m (30 ft. lbs.)
Skid Plate/Support Cushion	
Stud Nuts (YJ)	54 N•m (40 ft. lbs.)
Skid Plate-to-Sill Bolts (YJ)	88 N•m (65 ft. lbs.)
Support Cushion/Crossmember	
Nuts (XJ)	22 N•m (192 in. lbs.)
Support Cushion/Support Bracket	
Nuts (XJ Manual)	46 N•m (34 ft. lbs.)
Support Cushion/Torque Arm	
Bracket Nuts (YJ-Automatic)	54 N•m (40 ft. lbs.)
Torque Arm Bracket Bolts	
(YJ-Automatic)	54 N•m (40 ft. lbs.)

Description	Torque
Engine Mount—Rear (Cont.)	
Torque Arm Bracket/Support Cushion	
Bolts (YJ-Manual)	54 N•m (40 ft. lbs.)
Transmission Support Bracket	
Bolts (XJ-Manual)	43 N•m (32 ft. lbs.)
Transmission Support Bracket/Support	
Cushion Bolts (XJ 4WD Automatic)	75 N•m (55 ft. lbs.)
Transmission Support Adaptor	
Bracket Bolts (XJ 2WD Auto)	75 N•m (55 ft. lbs.)
Exhaust Manifold/Pipe Nuts	27 N•m (20 ft. lbs.)
Flywheel/Converter Housing Bolts	38 N•m (28 ft. lbs.)
Flywheel/Crankshaft Bolts	143 N•m (105 ft. lbs.)
Front Cover-to-Block Bolts (1/4-20)	7 N•m (60 in. lbs.)
Front Cover-to-Block Bolts (5/16-18)	22 N•m (192 in. lbs.)
Fuel Pump Bolts	22 N•m (16 ft. lbs.)
Generator Adjusting Bolt	24 N•m (18 ft. lbs.)
Generator Pivot Bolt/Nut	38 N•m (28 ft. lbs.)
Generator Mounting Bracket-to-	
Engine Bolts	38 N•m (28 ft. lbs.)
Generator Mounting/Head Bolts	45 N•m (33 ft. lbs.)
Main Bearing Bolts	108 N•m (80 ft. lbs.)
Oil Filter	18 N•m (13 ft. lbs.)
Oil Filter Connector	54 N•m (40 ft. lbs.)
Oil Galley Plug	41 N•m (30 ft. lbs.)
Oil Pan Bolts (1/4-20)	14 N•m (129 in. lbs.)
(5/16-18)	18 N•m (156 in. lbs.)
Oil Pan Drain Plug	34 N•m (25 ft. lbs.)
Oil Pump Attaching Bolts	
Short Bolts	14 N•m (10 ft. lbs.)
Long Bolts	23 N•m (17 ft. lbs.)
Oil Pump Cover Bolts	8 N•m (70 in. lbs.)
Power Steering Pump Pressure	
Hose Nut	52 N•m (38 ft. lbs.)
Rocker Arm Assembly-to-Cylinder	
Head Capscrews	28 N•m (21 ft. lbs.)
Spark Plugs	37 N•m (27 ft. lbs.)
Starting Motor Mounting Bolts	45 N•m (33 ft. lbs.)
Thermostat Housing	18 N•m (13 ft. lbs.)
Vibration Damper Bolts	108 N•m (80 ft. lbs.)
Water Pump/Block Bolts	31 N•m (270 in. lbs.)

J9409-43

4.0L ENGINE SERVICE PROCEDURES

INDEX

	page		page
Camshaft	69	Oil Pump	73
Camshaft Pin Replacement	71	Pistons and Connecting Rods	74
Crankshaft Main Bearings	80	Rear Main Oil Seals	84
Cylinder Block	85	Rocker Arms	59
Engine Assembly—XJ Vehicles	54	Specifications	87
Engine Assembly—YJ Vehicles	57	Timing Case Cover	67
Engine Cylinder Head	60	Timing Case Cover Oil Seal Replacement	67
Engine Cylinder Head Cover	59	Timing Chain and Sprockets	68
Engine Mount—Rear	52	Valve Springs and Oil Seals	62
Engine Mounts—Front	51	Valve Timing	66
General Information	50	Valves and Valve Springs	63
Hydraulic Tappets	65	Vibration Damper	67
Oil Pan	72		

GENERAL INFORMATION

The 4.0 Liter (242 CID) six-cylinder engine is an In-line, lightweight, overhead valve engine (Fig. 1).

Engine Type	In-line 6 Cylinder
Bore and Stroke	98.4x87.4mm (3.88x3.44 in.)
Displacement	4.0L (242 cu. in.)
Compression Ratio	8.7:1
Torque	
(XJ Vehicles)	305 N·m (225 ft. lbs.) @ 4000 rpm
(YJ Vehicles)	298 N·m (220 ft. lbs.) @ 4000 rpm
Firing Order	1-5-3-6-2-4
Lubrication	Pressure Feed—Full Flow Filtration
Engine Oil Capacity	5.7L (6 Quarts)
Cooling System	Liquid Cooled—Forced Circulation
Cooling System Capacity	
(XJ Vehicles)	11.4L (12 Quarts)
(YJ Vehicles)	9.9L (10.5 Quarts)
Cylinder Block	Cast Iron
Crankshaft	Cast Nodular Iron
Cylinder Head	Cast Iron
Camshaft	Cast Iron
Pistons	Aluminum Alloy (with Struts)
Pistons Combustion	
Cavity	Double Quench
Connecting Rods	Cast Iron

J9409-22

Fig. 1 Engine Description

This engine is designed for unleaded fuel.

The engine cylinder head has dual quench-type combustion chambers that create turbulence and fast burning of the air/fuel mixture. This results in good fuel economy.

The cylinders are numbered 1 through 6 from front to rear. The firing order is 1-5-3-6-2-4 (Fig. 2).

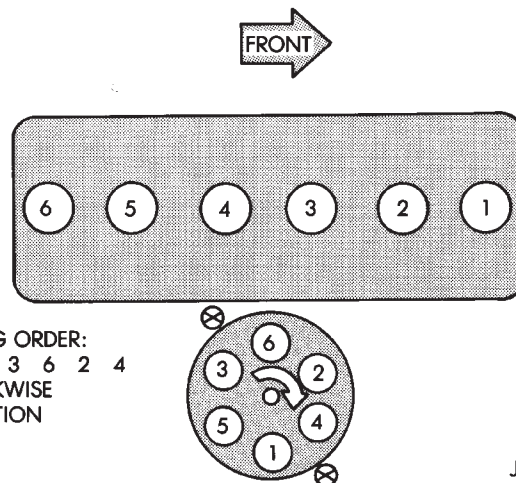

J908D-7

Fig. 2 Engine Firing Order

The crankshaft rotation is clockwise, when viewed from the front of the engine. The crankshaft rotates within seven main bearings. The camshaft rotates within four bearings.

BUILD DATE CODE

The engine Build Date Code is located on a machined surface on the right side of the cylinder block between the No.2 and No.3 cylinders (Fig. 3).

The digits of the code identify:

- (1) 1st Digit—The year (4 = 1994).
- (2) 2nd & 3rd Digits—The month (01 - 12).
- (3) 4th & 5th Digits—The engine type/fuel system/compression ratio (MX = A 4.0 Liter (242 CID) 8.7:1 compression ratio engine with a multi-point fuel injection system).
- (4) 6th & 7th Digits—The day of engine build (01 - 31).

FOR EXAMPLE: Code * 401MX12 * identifies a 4.0 liter (242 CID) engine with a multi-point fuel injection system, 8.7:1 compression ratio and built on January 12, 1994.

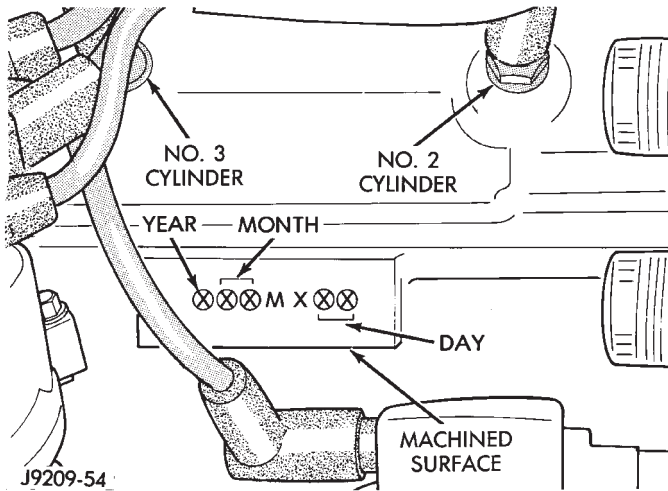

Fig. 3 Build Date Code Location

OVERSIZE AND UNDERSIZE COMPONENT CODES

Some engines may be built with oversize or undersize components such as:

- Oversize cylinder bores.
- Oversize camshaft bearing bores.
- Undersize crankshaft main bearing journals.
- Undersize connecting rod journals.

These engines are identified by a letter code (Fig. 4) stamped on a boss between the ignition coil and the distributor (Fig. 5).

CODE	COMPONENT	UNDERSIZE
P	One or more connecting rod bearing journals	0.254 mm (0.010 in)
M	All crankshaft main bearing journals	0.254 mm (0.010 in)
PM	All crankshaft main bearing journals and one or more connecting rod journals	0.254 mm (0.010 in)
CODE	COMPONENT	OVERSIZE
B	All cylinder bores	0.254 mm (0.010 in)
C	All camshaft bearing bores	0.254 mm (0.010 in)

J8909-54

Fig. 4 Oversize and Undersize Component Codes

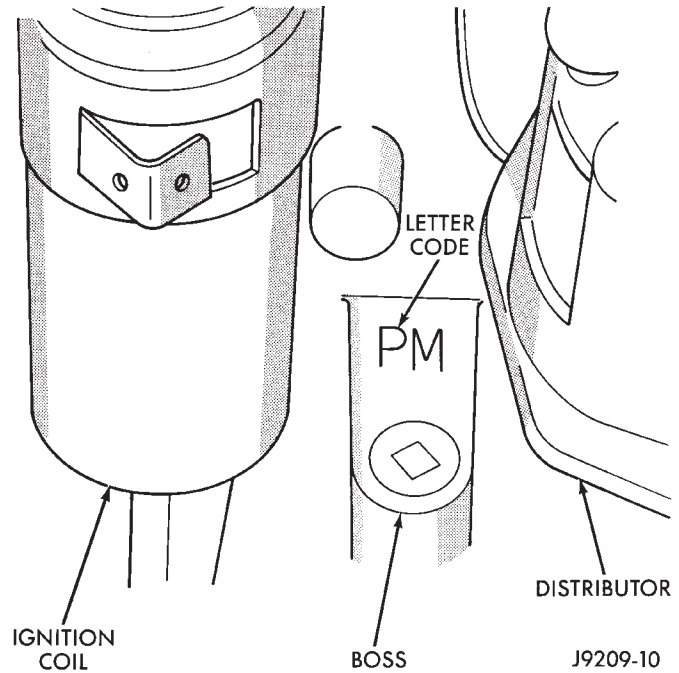

Fig. 5 Oversize and Undersize Component Code Location

ENGINE MOUNTS—FRONT

The front mounts support the engine at each side. These supports are made of resilient rubber.

REMOVAL

- (1) Disconnect negative cable from battery.
- (2) Raise the vehicle.
- (3) Support the engine.
- (4) Remove the nut from the through bolt (Figs. 6 and 7). **DO NOT** remove the through bolt.
- (5) Remove the retaining bolts/nuts from the support cushions (Figs. 6 and 7).
- (6) Remove the through bolt.
- (7) Remove the support cushions.

INSTALLATION

(1) If the engine support bracket was removed, position the bracket onto the block and install the attaching bolts (Figs. 6 and 7). Tighten the engine support bracket bolts:

- XJ Vehicles—61 N·m (45 ft. lbs.) torque.
- YJ Vehicles—62 N·m (46 ft. lbs.) torque.

(2) **ON XJ VEHICLES**, if the support cushion bracket was removed, position the bracket onto the lower front sill (Fig. 8). Install support cushion bracket bolts/nuts. Tighten the bolts to 54 N·m (40 ft. lbs.) torque. Tighten the nuts to 41 N·m (30 ft. lbs.) torque.

(3) Place the support cushion into position on the support cushion bracket (Figs. 6 and 7). Install and tighten the bolts/nuts:

- XJ Vehicles—41 N·m (30 ft. lbs.) torque.
- YJ Vehicles—52 N·m (38 ft. lbs.) torque.

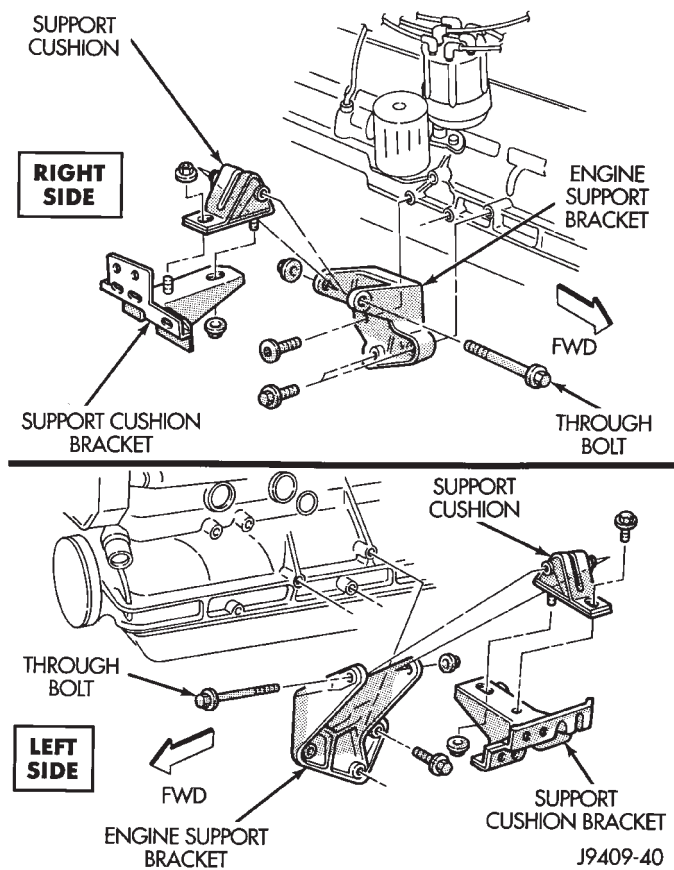

Fig. 6 Front Mounts—XJ Vehicles

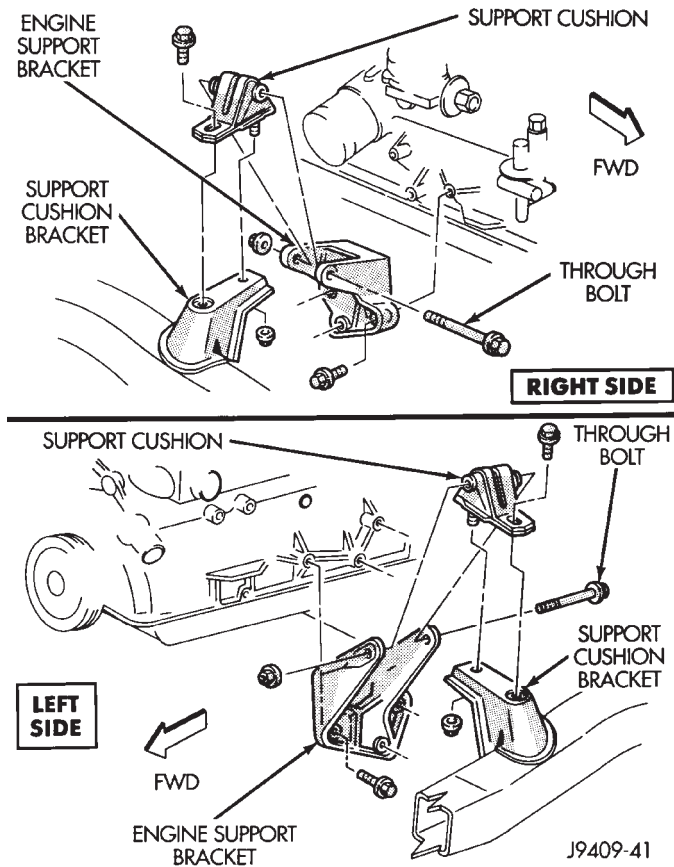

Fig. 7 Front Mounts—YJ Vehicles

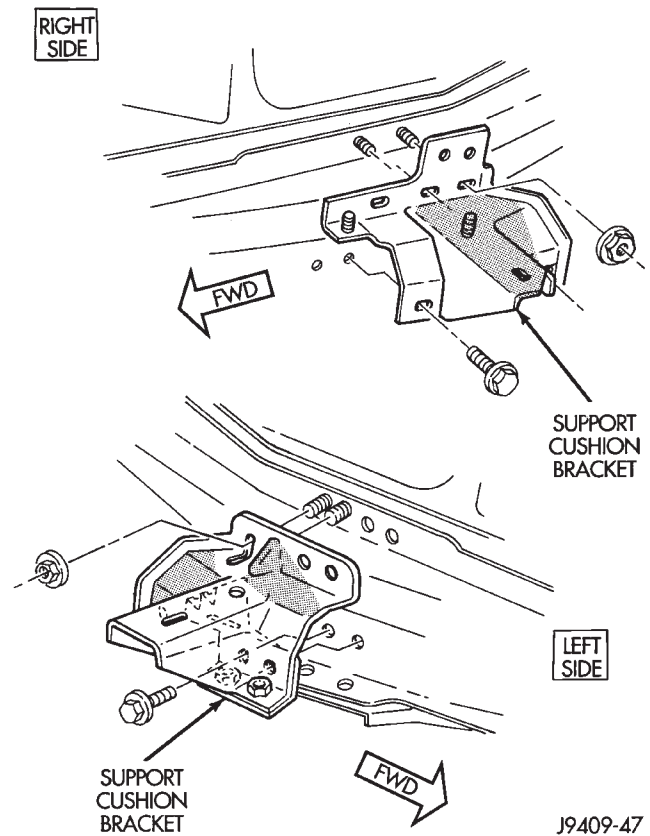

Fig. 8 Support Cushion Bracket—XJ Vehicles

(4) Install the through bolt and the retaining nut (Figs. 6 and 7). Tighten the through bolt nut:

- XJ Vehicles—65 N·m (48 ft. lbs.) torque.
- YJ Vehicles—69 N·m (51 ft. lbs.) torque.

- (5) Remove the engine support.
- (6) Lower the vehicle.
- (7) Connect negative cable to battery.

ENGINE MOUNT—REAR

A resilient rubber cushion supports the transmission at the rear between the transmission extension housing and the rear support crossmember or skid plate.

REMOVAL—XJ VEHICLES

- (1) Disconnect negative cable from battery.
- (2) Raise the vehicle and support the transmission.
- (3) Remove the nuts holding the support cushion to the crossmember (Figs. 9 and 10). Remove the crossmember.
- (4) **MANUAL TRANSMISSION (Fig. 9):**
 - (a) Remove the support cushion nuts and remove the cushion.
 - (b) Remove the transmission support bracket bolts and remove the bracket from the transmission.
- (5) **AUTOMATIC TRANSMISSION (Fig. 10):**

(a) Remove the support cushion bolts and remove the cushion and the support bracket from the transmission (4WD) or from the adaptor bracket (2WD).

(b) On 2WD vehicles, remove the bolts holding the transmission support adaptor bracket to the transmission (Fig. 10). Remove the adaptor bracket.

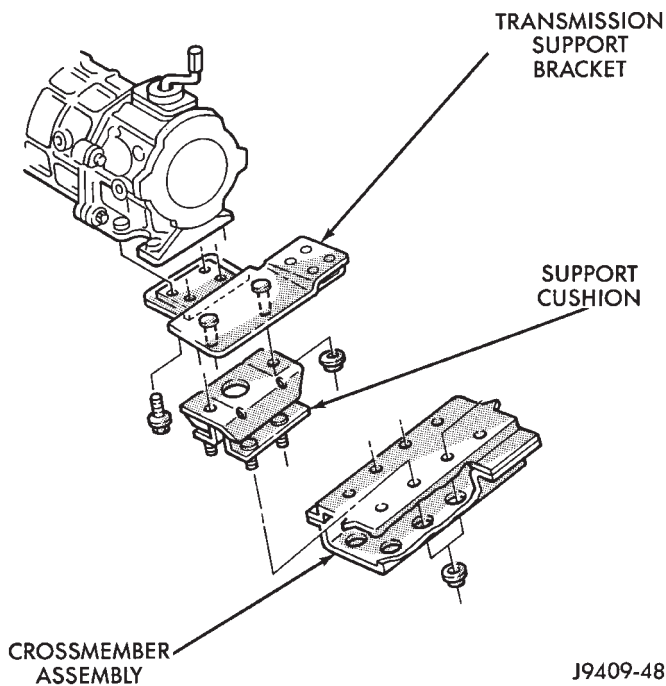

Fig. 9 Rear Mount—XJ Vehicles (Manual Transmission)

INSTALLATION—XJ VEHICLES

(1) MANUAL TRANSMISSION:

(a) Install the transmission support bracket to the transmission. Install the bolts and tighten to 46 N·m (34 ft. lbs.) torque.

(b) Install the support cushion to the support bracket. Install the nuts and tighten to 75 N·m (55 ft. lbs.) torque.

(2) AUTOMATIC TRANSMISSION:

(a) On 2WD vehicles, position the transmission support adaptor bracket to the transmission. Install the bolts and tighten to 75 N·m (55 ft. lbs.) torque.

(b) Position the transmission support bracket and support cushion to the adaptor bracket (2WD) or the transmission (4WD). Install the bolts and tighten to 75 N·m (55 ft. lbs.) torque.

(3) Position the crossmember onto the support cushion studs. Install the stud nuts and tighten to 22 N·m (192 in. lbs) torque.

(4) Install crossmember-to-sill bolts and tighten to 41 N·m (30 ft. lbs.) torque.

(5) Remove the transmission support.

(6) Lower the vehicle.

(7) Connect negative cable to battery.

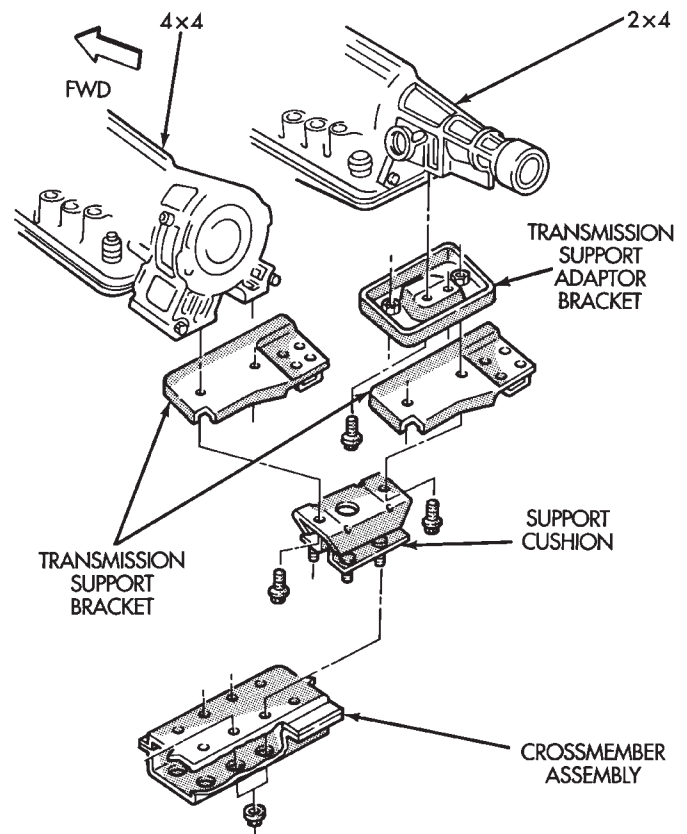

Fig. 10 Rear Mount—XJ Vehicles (Automatic Transmission)

REMOVAL—YJ VEHICLES

(1) Disconnect negative cable from battery.

(2) Raise the vehicle and support the transmission.

(3) MANUAL TRANSMISSION (Fig. 11):

(a) Remove the nuts holding the support cushion and the insulator to the skid plate. Remove the upper nut from the insulator stud.

(b) Remove the skid plate bolts and the skid plate. Remove the insulator stud assembly.

(c) Remove the support cushion nuts. Remove the support cushion from the torque arm bracket.

(d) Remove the torque arm bracket bolts and remove the bracket from the transmission.

(4) AUTOMATIC TRANSMISSION (Fig. 12):

(a) Remove the nuts holding the support cushion to the skid plate. Remove the skid plate.

(b) Remove the bolts and nuts holding the support cushion to the torque arm bracket. Remove the support cushion.

(c) Remove the bolts holding the torque arm bracket to the transmission. Remove the torque arm bracket.

INSTALLATION—YJ VEHICLES

(1) MANUAL TRANSMISSION:

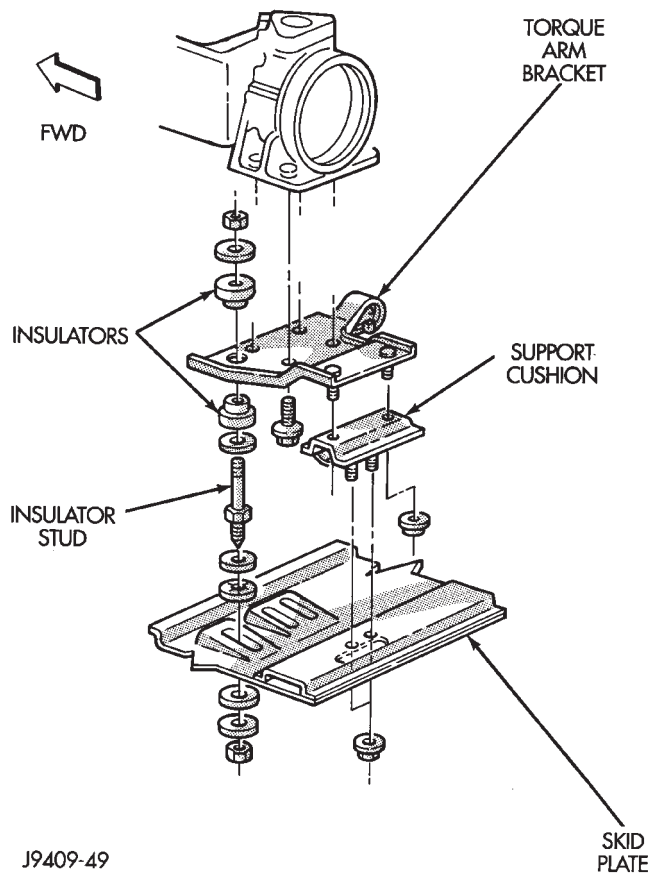

Fig. 11 Rear Mount—YJ Vehicles (Manual Transmission)

(a) Position the torque arm bracket to the transmission. Install the bolts and tighten to 54 N·m (40 ft. lbs.) torque.

(b) Position the support cushion onto the torque arm bracket. Install the nuts and tighten to 54 N·m (40 ft. lbs.) torque.

(c) Position the insulator stud assembly and upper nut (Fig. 11). Position the skid plate to the studs of the support cushion and the insulator stud (Fig. 11). Install the support cushion stud nuts and tighten to 54 N·m (40 ft. lbs.) torque. Install the lower stud nut and tighten the upper and lower insulator stud nuts to 41 N·m (30 ft. lbs.) torque.

(2) AUTOMATIC TRANSMISSION:

(a) Position the torque arm bracket to the transmission. Install the bolts and tighten to 54 N·m (40 ft. lbs.) torque.

(b) Position the support cushion onto the torque arm bracket. Install the bolts/nuts and tighten to 54 N·m (40 ft. lbs.) torque.

(c) Position the skid plate to the studs of the support cushion and install the nuts. Tighten the support cushion stud nuts to 54 N·m (40 ft. lbs.) torque.

(3) Install the skid plate bolts to the sill and tighten to 88 N·m (65 ft. lbs.) torque.

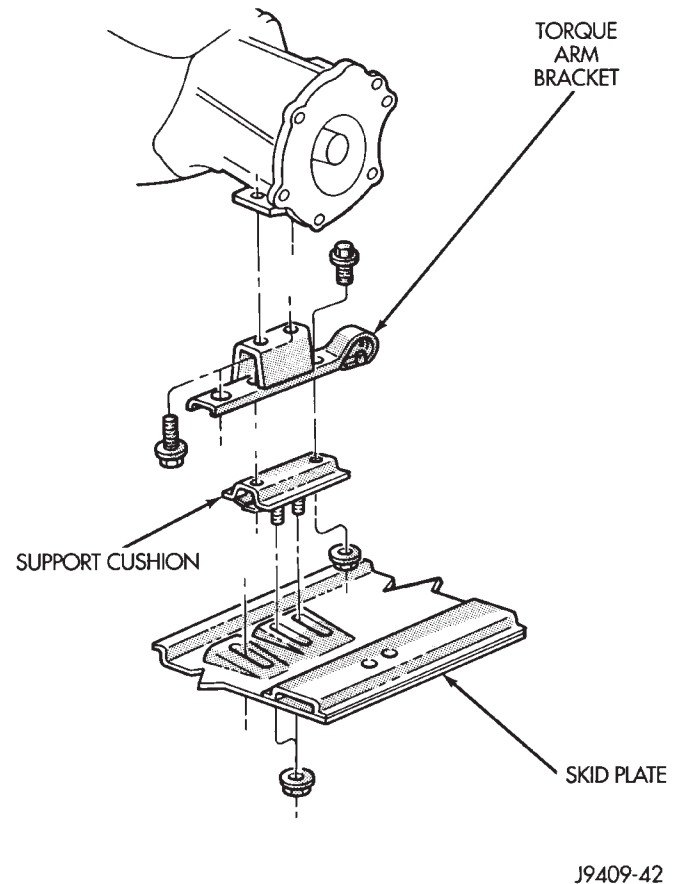

Fig. 12 Rear Mount—YJ Vehicles (Automatic Transmission)

(4) Remove the transmission support.

(5) Lower the vehicle.

(6) Connect negative cable to battery.

ENGINE ASSEMBLY—XJ VEHICLES

REMOVAL

(1) Disconnect the battery cables. Remove the battery.

(2) Mark the hinge locations on the hood panel for alignment reference during installation. Remove the engine compartment lamp. Remove the hood.

WARNING: THE COOLANT IN A RECENTLY OPERATED ENGINE IS HOT AND PRESSURIZED. USE CARE TO PREVENT SCALDING BY HOT COOLANT. CAREFULLY RELEASE THE PRESSURE BEFORE REMOVING THE RADIATOR DRAIN COCK AND CAP.

(3) Remove the radiator drain cock and radiator cap to drain the coolant. DO NOT waste usable coolant. If the solution is clean, drain the coolant into a clean container for reuse.

(4) Remove the lower radiator hose.

(5) Remove the upper radiator hose and coolant recovery hose (Fig. 13).

(6) Remove upper radiator support retaining bolts and remove radiator support.

(7) Remove the fan shroud (Fig. 13) and electric cooling fan.

(8) Disconnect the transmission fluid cooler tubing (automatic transmission).

(9) Disconnect radiator fan switch wire connector.

(10) Vehicles with Air Conditioning:

(a) Discharge the A/C condenser.

(b) Remove the service valves and cap the compressor ports.

(11) Remove the radiator or radiator/condenser (if equipped with A/C).

(12) Remove the fan assembly from the idler pulley.

(13) Disconnect the heater hoses at the engine thermostat housing and water pump (Figs. 13 and 14).

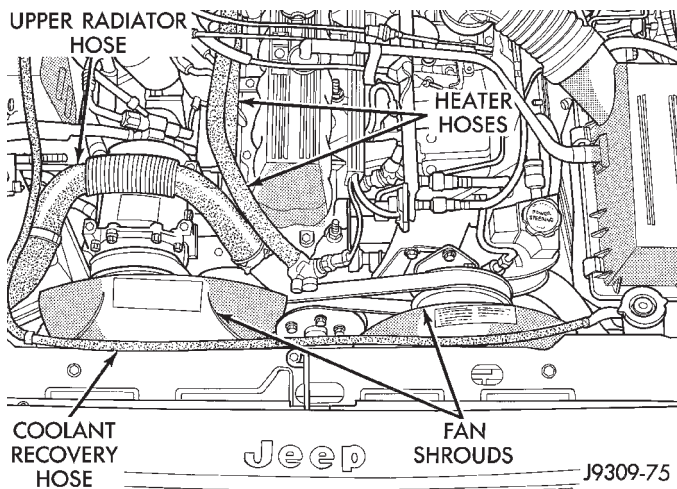

Fig. 13 Upper Radiator Hose, Coolant Recovery Hose, Fan Shroud & Heater hoses

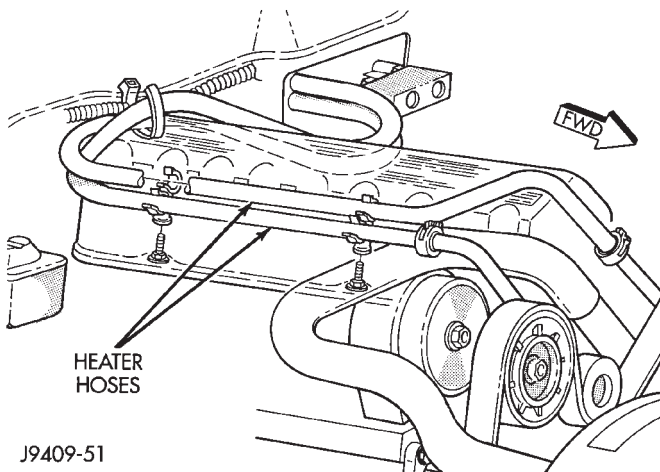

Fig. 14 Heater Hoses (RH Drive Vehicle)

(14) Disconnect the throttle linkages (Fig. 15).

(15) Disconnect the speed control cable (if equipped)—(Fig. 15).

(16) Disconnect the line pressure cable (if equipped with automatic transmission).

(17) Disconnect injection system wire harness connector at the dash panel.

(18) Disconnect the distributor electrical connection and the oil pressure switch connector.

(19) Disconnect the quick-connect fuel lines at the fuel rail and return line by squeezing the two retaining tabs against the fuel tube (Fig. 15). Pull the fuel tube and retainer from the quick-connect fitting (refer to Group 14, Fuel System for the proper procedure).

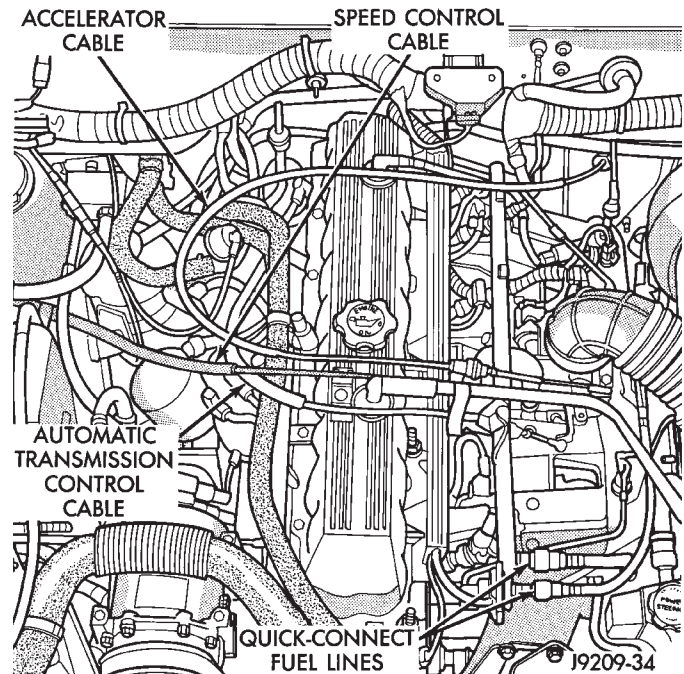

Fig. 15 Accelerator Cable, Speed Control Cable, Automatic Transmission Control Cable & Quick-Connect Fuel Lines

(20) Remove the fuel line bracket from the intake manifold.

(21) Remove the air cleaner assembly (Fig. 16).

(22) Remove the power brake vacuum check valve from the booster, if equipped.

(23) If equipped with power steering (Fig. 16):

(a) Disconnect the hoses from the fittings at the steering gear.

(b) Drain the pump reservoir.

(c) Cap the fittings on the hoses and steering gear to prevent foreign objects from entering the system.

(24) Identify, tag and disconnect all necessary wire connectors and vacuum hoses.

(25) Raise and support the vehicle.

(26) Disconnect the wires from the starter motor solenoid.

(27) Remove the starter motor.

(28) Disconnect the exhaust pipe from the manifold.

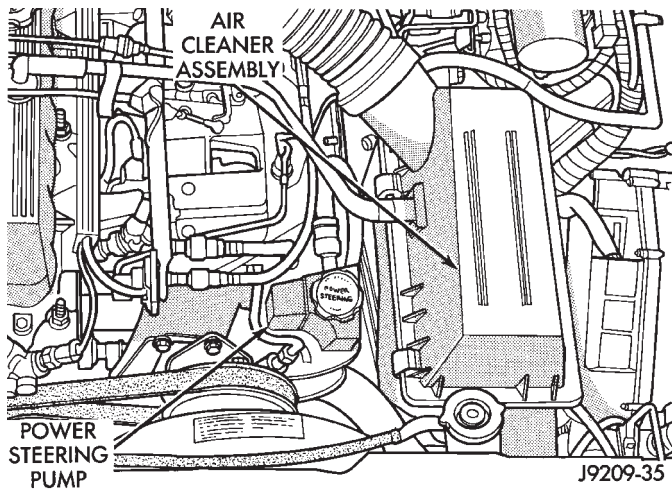

Fig. 16 Air Cleaner Assembly & Power Steering Pump

(29) Disconnect the engine speed sensor wire connection.

(30) Remove the exhaust pipe support.

(31) Remove the flywheel/converter housing access cover.

(32) **Vehicles with Automatic Transmission:**

(a) Mark the converter and drive plate location.

(b) Remove the converter-to-drive plate bolts.

(33) Remove the upper flywheel/converter housing bolts and loosen the bottom bolts.

(34) Remove the engine mount cushion-to-engine compartment bracket bolts.

(35) Lower the vehicle.

(36) Attach a lifting device to the engine.

(37) Raise the engine off the front supports.

(38) Place a support or floor jack under the converter (or flywheel) housing.

(39) Remove the remaining converter (or flywheel) housing bolts.

(40) Lift the engine out of the engine compartment.

INSTALLATION

CAUTION: When installing the engine into a vehicle equipped with an automatic transmission, be careful not to damage the trigger wheel on the flywheel.

(1) Attach a lifting device to the engine and lower the engine into the engine compartment. For easier installation, it may be necessary to remove the engine mount cushions from the engine mount bracket as an aide in alignment of the engine to the transmission.

(2) **Vehicles with Manual Transmission:**

(a) Insert the transmission shaft into the clutch spline.

(b) Align the flywheel housing with the engine.

(c) Install and tighten the flywheel housing lower bolts finger tight.

(3) **Vehicles with Automatic Transmission:**

(a) Align the transmission torque converter housing with the engine.

(b) Loosely install the converter housing lower bolts and install the next higher bolt and nut on each side.

(c) Tighten all 4 bolts finger tight.

(4) Install the engine mount cushions (if removed).

(5) Lower the engine and engine mount cushions onto the engine compartment brackets. Install the bolts and finger tighten the nuts.

(6) Remove the engine lifting device.

(7) Raise and support the vehicle.

(8) Install the remaining flywheel/converter housing bolts. Tighten all bolts to 38 N·m (28 ft. lbs.) torque.

(9) **Vehicles with Automatic Transmission:**

(a) Install the converter-to-drive plate bolts.

(b) Ensure the installation reference marks are aligned.

(10) Install the flywheel/converter housing access cover.

(11) Install the exhaust pipe support and tighten the screw.

(12) Tighten the engine mount-to-bracket bolts.

(13) Connect the engine speed sensor wire connections and tighten the screws.

(14) Connect the exhaust pipe to the manifold.

(15) Install the starter motor and connect the cable.

(16) Connect the wires to the starter motor solenoid.

(17) Lower the vehicle.

(18) Connect all the vacuum hoses and wire connectors identified during engine removal.

(19) If equipped with power steering:

(a) Remove the protective caps

(b) Connect the hoses to the fittings at the steering gear. Tighten the nut to 52 N·m (38 ft. lbs.) torque.

(c) Fill the pump reservoir with fluid.

(20) Install the power brake vacuum check valve to the booster, if equipped.

(21) Connect the fuel inlet and return hoses at the fuel rail. Verify that the quick-connect fitting assembly fits securely over the fuel lines by giving the fuel lines a firm tug.

(22) Install the fuel line bracket to the intake manifold.

(23) Connect the distributor electrical connector and oil pressure switch connector.

(24) Connect the injection system wire harness connector on the dash panel.

(25) Connect the line pressure cable (if equipped with automatic transmission).

(26) Connect the speed control cable, if equipped.

(27) Connect the throttle cable linkages.

- (28) Connect the heater hoses at the engine thermostat housing and water pump.
- (29) Install the fan assembly to the idler pulley.
- (30) Install the radiator or radiator/condenser (if equipped with A/C).
- (31) Connect the service valves to the A/C compressor ports, if equipped with A/C.
- (32) Charge the air conditioner system.
- (33) Connect radiator fan switch wire.
- (34) Connect the radiator hoses and automatic transmission fluid cooler pipes, if equipped.
- (35) Install the fan shroud, electric cooling fan and radiator/condenser (if equipped with A/C).
- (36) Install upper radiator support.
- (37) Connect the upper radiator hose and tighten the clamp.
- (38) Connect the lower radiator hose and tighten the clamp.
- (39) Fill the cooling system with reusable coolant and/or new coolant.
- (40) Align the hood to the scribe marks. Install the hood.
- (41) Connect the vacuum harness connector.
 - (a) Firmly push the connectors together ensuring that the retaining tabs are engaged.
 - (b) Insert the vacuum connector assembly into the retaining bracket on the intake manifold.
- (42) Install the air cleaner assembly.
- (43) Install the battery and connect the battery cable.

WARNING: USE EXTREME CAUTION WHEN THE ENGINE IS OPERATING. DO NOT STAND IN A DIRECT LINE WITH THE FAN. DO NOT PUT YOUR HANDS NEAR THE PULLEYS, BELTS OR FAN. DO NOT WEAR LOOSE CLOTHING.

- (44) Start the engine, inspect for leaks and correct the fluid levels, as necessary.

ENGINE ASSEMBLY—YJ VEHICLES

REMOVAL

- (1) Place a protective cloth over the windshield frame. Raise the hood and rest it on the windshield frame (Fig. 17).
- (2) Disconnect the battery cables. Remove the battery.

WARNING: THE COOLANT IN A RECENTLY OPERATED ENGINE IS HOT AND PRESSURIZED. USE CARE TO PREVENT SCALDING BY HOT COOLANT. CAREFULLY RELEASE THE PRESSURE BEFORE REMOVING THE RADIATOR DRAIN COCK AND CAP.

- (3) Remove the radiator drain cock and radiator cap to drain the coolant. DO NOT waste reusable

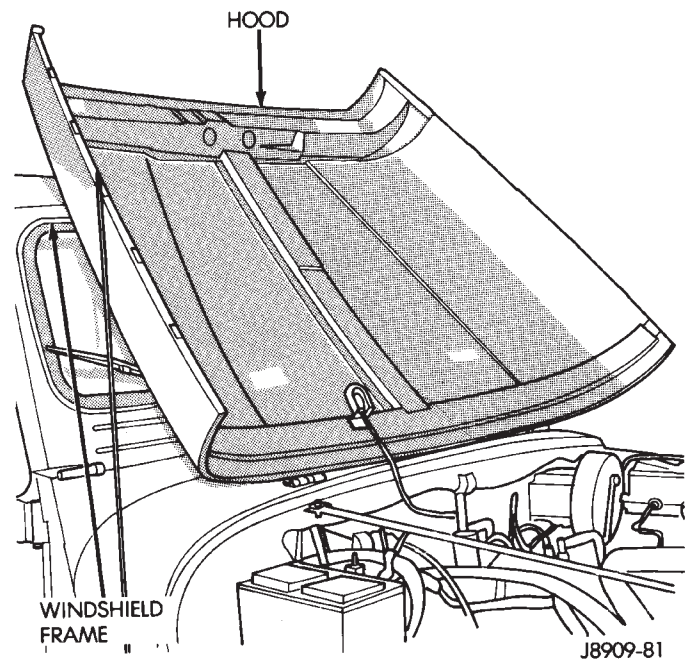

Fig. 17 Hood on Windshield Frame

coolant. If the solution is clean, drain the coolant into a clean container for reuse.

- (4) Disconnect the wire connectors from the generator.
- (5) Disconnect the ignition coil and distributor wire connectors.
- (6) Disconnect the oil pressure sender wire connector.
- (7) Disconnect the wires at the starter motor solenoid and injection wire harness connector.
- (8) Disconnect the quick-connect fuel lines at the fuel rail and return line by squeezing the retaining tabs against the fuel tube (Fig. 18). Pull the fuel tube and retainer from the quick-connect fitting (refer to Group 14, Fuel System for the proper procedure).
- (9) Remove the fuel line bracket from the intake manifold.
- (10) Disconnect the engine ground strap.
- (11) Remove the air cleaner (Fig. 18).
- (12) Disconnect the vacuum purge hose at the fuel vapor canister tee.
- (13) Disconnect the idle speed actuator wire connector.
- (14) Disconnect the throttle cable and remove it from the bracket (Fig. 18).
- (15) Disconnect the throttle rod at the bellcrank.
- (16) Disconnect the speed control cable, if equipped (Fig. 18).
- (17) Disconnect the oxygen sensor wire connector.
- (18) Remove the upper radiator hose and coolant recovery hose (Fig. 19).
- (19) Disconnect lower radiator hoses at the radiator.

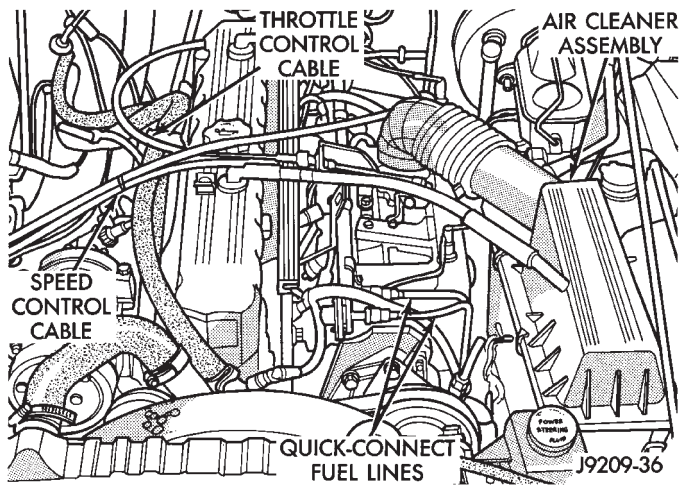

Fig. 18 Fuel Line Quick-Connect Couplings, Air Cleaner Assembly, Throttle & Speed Control Cables

(20) Disconnect the coolant hoses from the rear of the intake manifold and thermostat housing.

(21) Remove the fan shroud screws.

(22) Remove the radiator attaching bolts.

(23) Remove the radiator and fan shroud (Fig. 19). Refer to Group 7, Cooling System for the proper procedure.

(24) Remove the fan and spacer or Tempatrol fan assembly.

(25) Install a 5/16 X 1/2-inch SAE capscrew through fan pulley into water pump flange. This will maintain the pulley and water pump in alignment when crankshaft is rotated.

(26) Remove the power brake vacuum check valve from the booster, if equipped.

(27) If equipped with power steering (Fig. 19):

(a) Disconnect the hoses from the fittings at the steering gear.

(b) Drain the pump reservoir.

(c) Cap the fittings on the hoses and steering gear to prevent foreign objects from entering the system.

(28) Lift the vehicle and support it with support stands.

(29) Remove the starter motor.

(30) Remove the flywheel housing access cover.

(31) Remove the engine support cushion-to-bracket through bolts.

(32) Disconnect the exhaust pipe from the manifold.

(33) Remove the upper flywheel housing bolts and loosen the bottom bolts.

(34) Lower the vehicle.

(35) Attach a lifting device to the engine.

(36) Raise the engine off the front supports.

(37) Place a support stand under the flywheel housing.

(38) Remove the remaining flywheel housing bolts.

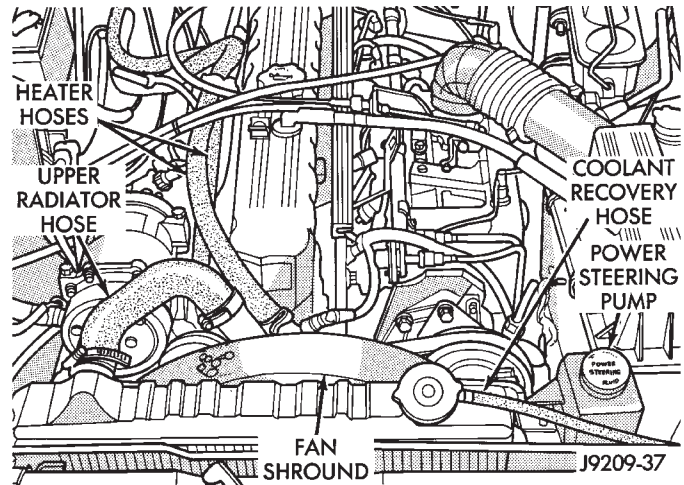

Fig. 19 Upper Radiator Hose, Coolant Recovery Hose, Fan Shroud & Power Steering Pump

(39) Lift the engine out of the engine compartment and install on an engine stand.

INSTALLATION

(1) Lift the engine off the stand and lower it into the engine compartment. For easier installation, it may be useful to remove the engine support cushions from the engine support brackets as an aide for alignment of the engine-to-transmission.

(2) Insert the transmission shaft into the clutch spline.

(3) Align the flywheel housing with the engine.

(4) Install and finger tighten the flywheel housing lower bolts.

(5) Install the engine support cushions (if removed).

(6) Remove the support stand from beneath the flywheel housing.

(7) Lower the engine and engine support cushions onto the engine compartment brackets. Ensure that the bolt holes are aligned. Install the bolts and tighten the nuts.

(8) Remove the engine lifting device.

(9) Raise the vehicle.

(10) Attach the exhaust pipe to the manifold. Install and tighten the nuts to 31 N·m (23 ft. lbs.) torque.

(11) Install the flywheel housing access cover.

(12) Install the remaining flywheel housing bolts. Tighten the bolts to 38 N·m (28 ft. lbs.) torque.

(13) Install the starter motor and connect the cable. Tighten the bolts to 45 N·m (33 ft. lbs.) torque.

(14) Lower the vehicle.

(15) Connect the coolant hoses and tighten the clamps.

(16) Remove the pulley-to-water pump flange alignment capscrew and install the fan and spacer or Tempatrol fan assembly.

- (17) Tighten the serpentine drive belt according to the specifications listed in Group 7, Cooling System.
- (18) Install the fan shroud and radiator (refer to Group 7, Cooling System for the proper procedure).
- (19) Connect the radiator hoses.
- (20) Connect the throttle valve rod and retainer.
- (21) Connect the throttle cable and install the rod.
- (22) Install the throttle valve rod spring.
- (23) Connect the speed control cable, if equipped.
- (24) Connect the oxygen sensor wire connector.
- (25) Install the vacuum hose and check valve on the brake booster.
- (26) Connect the coolant temperature sensor wire connector.
- (27) Connect the idle speed actuator wire connector.
- (28) Connect the fuel inlet and return hoses at the fuel rail. Verify that the quick-connect fitting assembly fits securely over the fuel lines by giving the fuel lines a firm tug.
- (29) Install the fuel line bracket to the intake manifold.
- (30) Connect all fuel injection wire connections.
- (31) Install the engine ground strap.
- (32) Connect the ignition coil wire connector.
- (33) Remove the coolant temperature sending unit to permit air to escape from the block. Fill the cooling system with coolant. Install the coolant temperature sending unit when the system is filled.
- (34) If equipped with power steering:
 - (a) Remove the protective caps
 - (b) Connect the hoses to the fittings at the steering gear. Tighten the nut to 52 N·m (38 ft. lbs.) torque.
 - (c) Fill the pump reservoir with fluid.
- (35) Install the battery and connect the battery cables.
- (36) Install the air cleaner bonnet to the throttle body.
- (37) Install the air cleaner.
- (38) Lower the hood and secure in place.
- (39) Start the engine and inspect for leaks.
- (40) Stop the engine and check the fluid levels. Add fluid, as required.

ENGINE CYLINDER HEAD COVER

A cured gasket is part of the engine cylinder head cover.

REMOVAL

- (1) Disconnect negative cable from battery.
- (2) Disconnect the Crankcase Ventilation (CCV) vacuum hose from engine cylinder head cover (Fig. 1).
- (3) Disconnect the fresh air inlet hose from the engine cylinder head cover (Fig. 1).
- (4) Remove the engine cylinder head cover mounting bolts.

- (5) Remove the engine cylinder head cover.

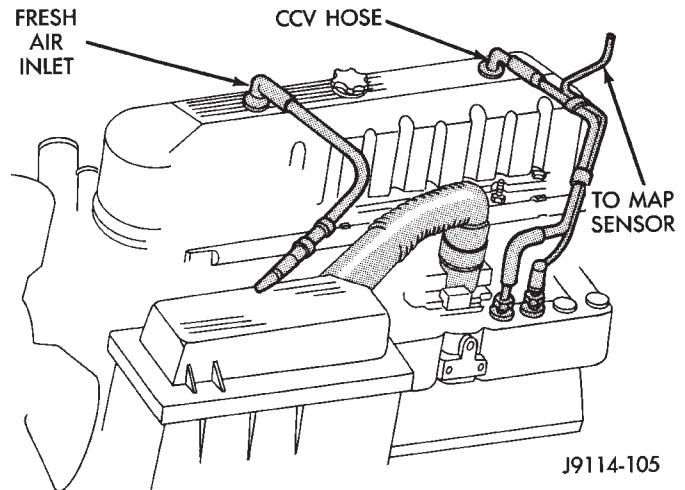

Fig. 1 Engine Cylinder Head Cover

CLEANING

Remove any original sealer from the cover sealing surface of the engine cylinder head and clean the surface using a fabric cleaner.

Remove all residue from the sealing surface using a clean, dry cloth.

INSPECTION

Inspect the engine cylinder head cover for cracks. Replace the cover, if cracked.

The original grey gasket material should NOT be removed. If sections of the gasket material are missing or are compressed, replace the engine cylinder head cover. However, sections with minor damage such as small cracks, cuts or chips may be repaired with a hand held applicator. The new material must be smoothed over to maintain gasket height. Allow the gasket material to cure prior to engine cylinder head cover installation.

INSTALLATION

- (1) If a replacement cover is installed, transfer the CCV valve grommet and oil filler cap from the original cover to the replacement cover.
- (2) Install engine cylinder head cover. Tighten the mounting bolts to 10 N·m (85 in. lbs.) torque.
- (3) Connect the CCV hoses (Fig. 1).
- (4) Connect negative cable to battery.

ROCKER ARMS

This procedure can be done with the engine in or out of the vehicle.

REMOVAL

- (1) Remove the engine cylinder head cover.
- (2) Remove the capscrews at each bridge and pivot assembly (Fig. 2). Alternately loosen the capscrews one turn at a time to avoid damaging the bridges.

(3) Check for rocker arm bridges which are causing misalignment of the rocker arm to valve tip area.

(4) Remove the bridges, pivots and corresponding pairs of rocker arms (Fig. 2). Place them on a bench in the same order as removed.

(5) Remove the push rods and place them on a bench in the same order as removed.

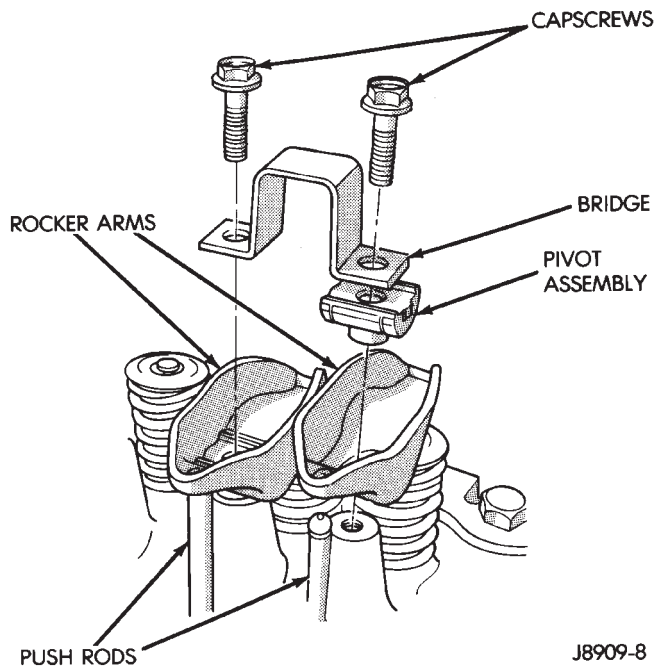

Fig. 2 Rocker Arm Assembly

CLEANING

Clean all the components with cleaning solvent.

Use compressed air to blow out the oil passages in the rocker arms and push rods.

INSPECTION

Inspect the pivot surface area of each rocker arm. Replace any that are scuffed, pitted, cracked or excessively worn.

Inspect the valve stem tip contact surface of each rocker arm and replace any rocker arm that is deeply pitted.

Inspect each push rod end for excessive wear and replace as required. If any push rod is excessively worn because of lack of oil, replace it and inspect the corresponding hydraulic tappet for excessive wear.

Inspect the push rods for straightness by rolling them on a flat surface or by shining a light between the push rod and the flat surface.

A wear pattern along the length of the push rod is not normal. Inspect the engine cylinder head for obstruction if this condition exists.

INSTALLATION

(1) Lubricate the ball ends of the push rods with Mopar Engine Oil Supplement, or equivalent and install push rods in their original locations. Ensure

that the bottom end of each push rod is centered in the tappet plunger cap seat.

(2) Using Mopar Engine Oil Supplement, or equivalent, lubricate the area of the rocker arm that the pivot contacts. Install rocker arms, pivots and bridge above each cylinder in their originally position.

(3) Loosely install the capscrews through each bridge.

(4) At each bridge, tighten the capscrews alternately, one turn at a time, to avoid damaging the bridge. Tighten the capscrews to 28 N·m (21 ft. lbs.) torque.

(5) Install the engine cylinder head cover.

ENGINE CYLINDER HEAD

This procedure can be done with the engine in or out of the vehicle.

REMOVAL

(1) Disconnect negative cable from battery.

WARNING: DO NOT REMOVE THE CYLINDER BLOCK DRAIN PLUGS OR LOOSEN THE RADIATOR DRAIN COCK WITH THE SYSTEM HOT AND PRESSURIZED BECAUSE SERIOUS BURNS FROM THE COOLANT CAN OCCUR.

(2) Drain the coolant and disconnect the hoses at the engine thermostat housing. **DO NOT** waste reusable coolant. If the solution is clean and is being drained only to service the engine or cooling system, drain the coolant into a clean container for reuse.

(3) Remove the air cleaner assembly.

(4) Remove the engine cylinder head cover.

(5) Remove the capscrews, bridge and pivot assemblies and rocker arms (Fig. 2).

(6) Remove the push rods (Fig. 2). **Retain the push rods, bridges, pivots and rocker arms in the same order as removed.**

(7) Loosen the serpentine drive belt at the power steering pump, if equipped or at the idler pulley (refer to Group 7, Cooling System for the proper procedure).

(8) If equipped with air conditioning, perform the following:

(a) Remove the bolts from the A/C compressor mounting bracket and set the compressor aside.

(b) Remove the air conditioner compressor bracket bolts from the engine cylinder head.

(c) Loosen the through bolt at the bottom of the bracket.

(9) If equipped, disconnect the power steering pump bracket. Set the pump and bracket aside. **DO NOT** disconnect the hoses.

(10) Remove the fuel lines and vacuum advance hose.

(11) Remove the intake and engine exhaust manifolds from the engine cylinder head (refer to Group 11, Exhaust System and Intake Manifold for the proper procedures).

(12) Disconnect the ignition wires and remove the spark plugs.

(13) Disconnect the temperature sending unit wire connector.

(14) Remove the ignition coil and bracket assembly.

(15) Remove the engine cylinder head bolts. Bolt No.14 cannot be removed until the head is moved forward (Fig. 3). Pull bolt No.14 out as far as it will go and then suspend the bolt in this position (tape around the bolt).

(16) Remove the engine cylinder head and gasket (Fig. 3).

(17) If this was the first time the bolts were removed, put a paint dab on the top of the bolt. If the bolts have a paint dab on the top of the bolt or it isn't known if they were used before, discard the bolts.

(18) Stuff clean lint free shop towels into the cylinder bores.

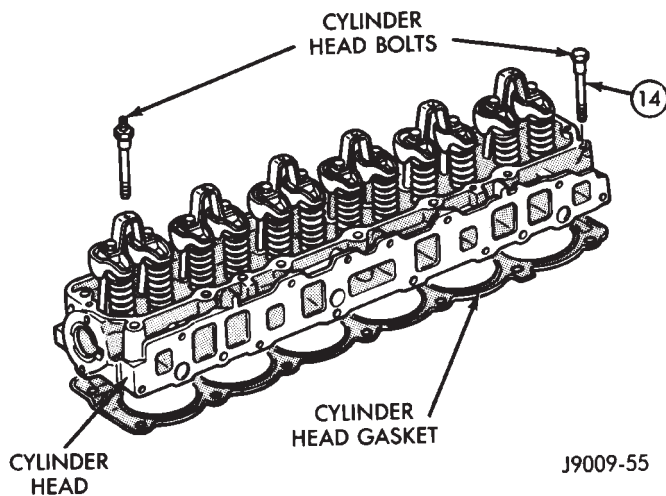

Fig. 3 Engine Cylinder Head Assembly

CLEANING

Thoroughly clean the engine cylinder head and cylinder block mating surfaces. Clean the intake and engine exhaust manifold and engine cylinder head mating surfaces. Remove all gasket material and carbon.

Check to ensure that no coolant or foreign material has fallen into the tappet bore area.

Remove the carbon deposits from the combustion chambers and top of the pistons.

INSPECTION

Use a straightedge and feeler gauge to check the flatness of the engine cylinder head and block mating surfaces.

INSTALLATION

The engine cylinder head gasket is a composition gasket. The gasket is to be installed DRY. **DO NOT use a gasket sealing compound on the gasket.**

If the engine cylinder head is to be replaced and the original valves used, measure the valve stem diameter. Only standard size valves can be used with a service replacement engine cylinder head unless the replacement head valve stem guide bores are reamed to accommodate oversize valve stems. Remove all carbon buildup and reface the valves.

(1) Remove the shop towels from the cylinder bores. Coat the bores with clean engine oil.

(2) Position the engine cylinder head gasket (with the numbers facing up) onto the cylinder block.

CAUTION: Engine cylinder head bolts should be re-used only once. Replace the head bolts if they were used before or if they have a paint dab on the top of the bolt.

(3) With bolt No.14 held in place (tape around bolt), install the engine cylinder head. Remove the tape from bolt No.14.

(4) Coat the threads of stud bolt No.11 with Loctite 592 sealant, or equivalent.

(5) Tighten the engine cylinder head bolts in sequence according to the following procedure (Fig. 4):

(a) Tighten all bolts in sequence (1 through 14) to 30 N·m (22 ft. lbs.) torque.

(b) Tighten all bolts in sequence (1 through 14) to 61 N·m (45 ft. lbs.) torque.

(c) Check all bolts to verify they are set to 61 N·m (45 ft. lbs.) torque.

(d) Tighten bolts (in sequence):

- Bolts 1 through 10 to 149 N·m (110 ft. lbs.) torque.
- Bolt 11 to 136 N·m (100 ft. lbs.) torque.
- Bolts 12 through 14 to 149 N·m (110 ft. lbs.) torque.

CAUTION: During the final tightening sequence, bolt No.11 will be tightened to a lower torque than the rest of the bolts. DO NOT overtighten bolt No.11.

(e) Check all bolts in sequence to verify the correct torque.

(f) If not already done, clean and mark each bolt with a dab of paint after tightening. Should you encounter bolts which were painted in an earlier service operation, replace them.

(6) Install the ignition coil and bracket assembly.

(7) Connect the temperature sending unit wire connector.

(8) Install the spark plugs and tighten to 37 N·m (27 ft. lbs.) torque. Connect the ignition wires.

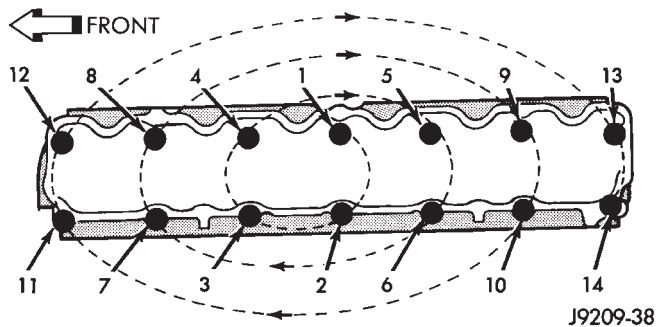

Fig. 4 Engine Cylinder Head Bolt Tightening Sequence

(9) Install the intake and engine exhaust manifolds (refer to Group 11, Exhaust System and Intake Manifold for the proper procedures).

(10) Install the fuel lines and the vacuum advance hose.

(11) If equipped, attach the power steering pump and bracket.

(12) Install the push rods, rocker arms, pivots and bridges in the order they were removed.

(13) Install the engine cylinder head cover.

(14) Attach the air conditioner compressor mounting bracket to the engine cylinder head and block. Tighten the bolts to 40 N·m (30 ft. lbs.) torque.

(15) Attach the air conditioning compressor to the bracket. Tighten the bolts to 27 N·m (20 ft. lbs.) torque.

CAUTION: The serpentine drive belt must be routed correctly. Incorrect routing can cause the water pump to turn in the opposite direction causing the engine to overheat.

(16) Install the serpentine drive belt and correctly tension the belt (refer to Group 7, Cooling System for the proper procedure).

(17) Install the air cleaner and ducting.

(18) Install the engine cylinder head cover.

(19) Connect the hoses to the engine thermostat housing and fill the cooling system to the specified level (refer to Group 7, Cooling Systems for the proper procedure).

(20) The automatic transmission throttle linkage and cable must be adjusted after completing the engine cylinder head installation (refer to Group 21, Transmissions for the proper procedures).

(21) Install the temperature sending unit and connect the wire connector.

(22) Connect the fuel pipe and vacuum advance hose.

(23) Connect negative cable to battery.

(24) Connect the upper radiator hose and heater hose at the engine thermostat housing.

(25) Fill the cooling system. Check for leaks.

WARNING: USE EXTREME CAUTION WHEN THE ENGINE IS OPERATING. DO NOT STAND IN DIRECT LINE WITH THE FAN. DO NOT PUT HANDS NEAR THE PULLEYS, BELTS OR FAN. DO NOT WEAR LOOSE CLOTHING.

(26) Operate the engine with the radiator cap off. Inspect for leaks and continue operating the engine until the engine thermostat opens. Add coolant, if required.

VALVE SPRINGS AND OIL SEALS

This procedure can be done with the engine cylinder head installed on the block.

REMOVAL

Each valve spring is held in place by a retainer and a set of conical valve locks. The locks can be removed only by compressing the valve spring.

(1) Remove the engine cylinder head cover.

(2) Remove capscrews, bridge and pivot assemblies and rocker arms for access to each valve spring to be removed.

(3) Remove push rods. Retain the push rods, bridges, pivots and rocker arms in the same order and position as removed.

(4) Inspect the springs and retainer for cracks and possible signs of weakening.

(5) Remove the spark plug(s) adjacent to the cylinder(s) below the valve springs to be removed.

(6) Install a 14 mm (1/2 inch) (thread size) air hose adaptor in the spark plug hole. An adaptor can be constructed by welding an air hose connection to the body of a spark plug with the porcelain removed.

(7) Connect an air hose to the adapter and apply air pressure slowly. Maintain at least 621 kPa (90 psi) of air pressure in the cylinder to hold the valves against their seats. For vehicles equipped with an air conditioner, use a flexible air adaptor when servicing the No.1 cylinder.

(8) Tap the retainer or tip with a rawhide hammer to loosen the lock from the retainer. Use Valve Spring Compressor Tool MD-998772A to compress the spring and remove the locks (Fig. 5).

(9) Remove valve spring and retainer (Fig. 5).

(10) Remove valve stem oil seals (Fig. 5). Note the valve seals are different for intake and exhaust valves. The top of each seal is marked either INT (Intake) or EXH (Exhaust). DO NOT mix the seals.

INSPECTION

Inspect the valve stems, especially the grooves. An Arkansas smooth stone should be used to remove nicks and high spots.

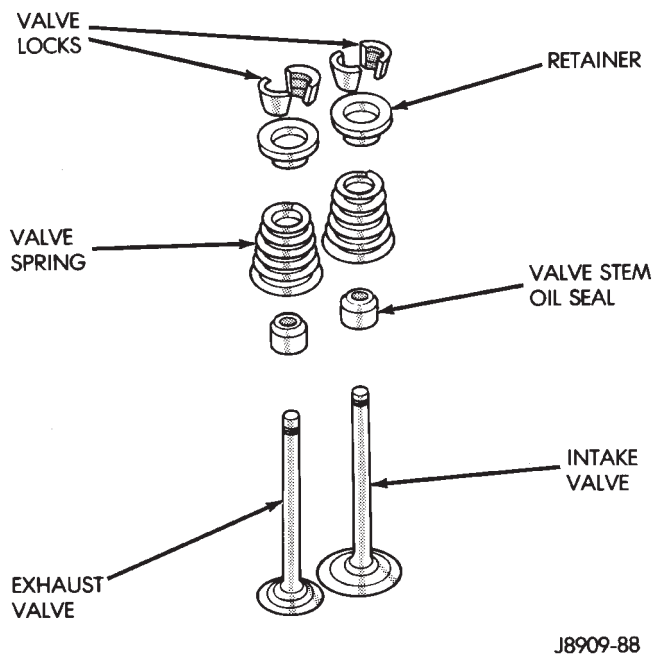

Fig. 5 Valve and Valve Components

INSTALLATION

CAUTION: Install oil seals carefully to prevent damage from the sharp edges of the valve spring lock groove.

- (1) Lightly push the valve seal over the valve stem and valve guide boss. Be sure the seal is completely seated on the valve guide boss.
- (2) Install valve spring and retainer.
- (3) Compress the valve spring with Valve Spring Compressor Tool MD-998772A and insert the valve locks. Release the spring tension and remove the tool. Tap the spring from side-to-side to ensure that the spring is seated properly on the engine cylinder head.
- (4) Disconnect the air hose. Remove the adaptor from the spark plug hole and install the spark plug.
- (5) Repeat the procedures for each remaining valve spring to be removed.
- (6) Install the push rods. Ensure the bottom end of each rod is centered in the plunger cap seat of the hydraulic valve tappet.
- (7) Install the rocker arms, pivots and bridge at their original location.
- (8) Tighten the bridge capscrews alternately, one at a time, to avoid damaging the bridge. Tighten the capscrews to 28 N·m (21 ft. lbs.) torque.
- (9) Install the engine cylinder head cover.

VALVES AND VALVE SPRINGS

This procedure is done with the engine cylinder head removed from the block.

REMOVAL

- (1) Remove the engine cylinder head from the cylinder block.
- (2) Use Valve Spring Compressor Tool MD-998772A and compress each valve spring.
- (3) Remove the valve locks, retainers, springs and valve stem oil seals. Discard the oil seals.
- (4) Use an Arkansas smooth stone or a jewelers file to remove any burrs on the top of the valve stem, especially around the groove for the locks.
- (5) Remove the valves, and place them in a rack in the same order as removed.

VALVE CLEANING

Clean all carbon deposits from the combustion chambers, valve ports, valve stems, valve stem guides and head.

Clean all grime and gasket material from the engine cylinder head machined gasket surface.

INSPECTION

Inspect for cracks in the combustion chambers and valve ports.

Inspect for cracks on the exhaust seat.

Inspect for cracks in the gasket surface at each coolant passage.

Inspect valves for burned, cracked or warped heads.

Inspect for scuffed or bent valve stems.

Replace valves displaying any damage.

VALVE REFACING

(1) Use a valve refacing machine to reface the intake and exhaust valves to the specified angle.

(2) After refacing, a margin of at least 0.787 mm (0.031 inch) must remain (Fig. 6). If the margin is less than 0.787 mm (0.031 inch), the valve must be replaced.

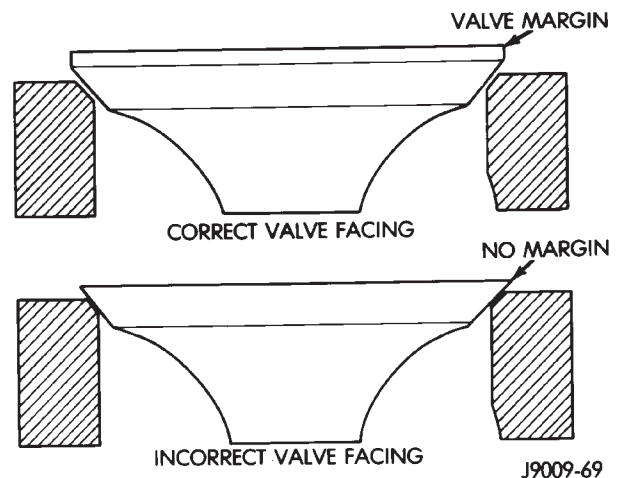

Fig. 6 Valve Facing Margin

VALVE SEAT REFACING

(1) Install a pilot of the correct size in the valve guide bore. Reface the valve seat to the specified an-

gle with a good dressing stone. Remove only enough metal to provide a smooth finish.

(2) Use tapered stones to obtain the specified seat width when required.

(3) Control valve seat runout to a maximum of 0.0635 mm (0.0025 in.)—(Fig. 7).

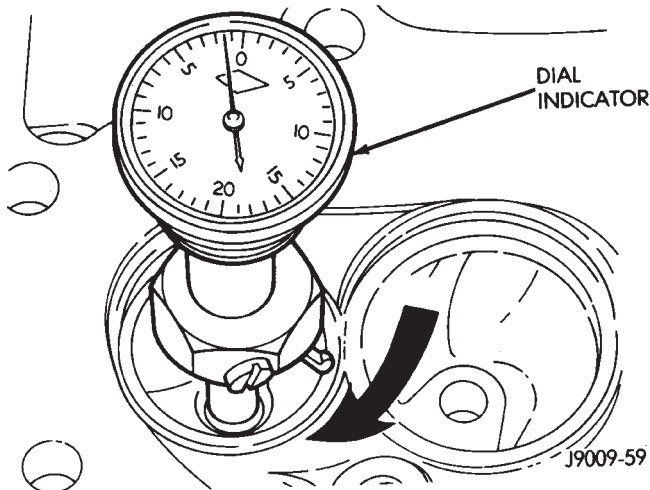

Fig. 7 Measurement of Valve Seat Runout

VALVE STEM OIL SEAL REPLACEMENT

Valve stem oil seals are installed on each valve stem to prevent rocker arm lubricating oil from entering the combustion chamber through the valve guide bores. One seal is marked INT (intake valve) and the other is marked EXH (exhaust valve).

Replace the oil seals whenever valve service is performed or if the seals have deteriorated.

VALVE GUIDES

The valve guides are an integral part of the engine cylinder head and are not replaceable.

When the valve stem guide clearance is excessive, the valve guide bores must be reamed oversize. Service valves with oversize stems are available in 0.076 mm (0.003 inch) and 0.381 mm (0.015 inch) increments.

Corresponding oversize valve stem seals are also available and must be used with valves having 0.381 mm (0.015 inch) oversize stems.

If the valve guides are reamed oversize, the valve seats must be ground to ensure that the valve seat is concentric to the valve guide.

VALVE STEM-TO-GUIDE CLEARANCE MEASUREMENT

Valve stem-to-guide clearance may be measured by either of the following two methods.

PREFERRED METHOD:

- (1) Remove the valve from the head.
- (2) Clean the valve stem guide bore with solvent and a bristle brush.
- (3) Insert a telescoping gauge into the valve stem

guide bore approximately 9.525 mm (.375 inch) from the valve spring side of the head (Fig. 8).

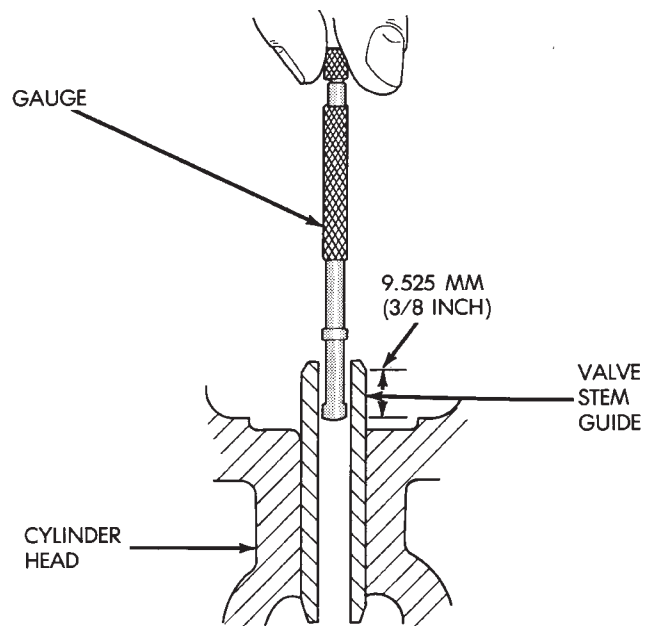

Fig. 8 Measurement of Valve Guide Bore Diameter

(4) Remove and measure telescoping gauge with a micrometer.

(5) Repeat the measurement with contacts lengthwise to engine cylinder head.

(6) Compare the crosswise to lengthwise measurements to determine out-of-roundness. If the measurements differ by more than 0.0635 mm (0.0025 in.), ream the guide bore to accommodate an oversize valve stem.

(7) Compare the measured valve guide bore diameter with specifications (7.95-7.97 mm or 0.313-0.314 inch). If the measurement differs from specification by more than 0.076 mm (0.003 inch), ream the guide bore to accommodate an oversize valve stem.

ALTERNATIVE METHOD:

(1) Use a dial indicator to measure the lateral movement of the valve stem (stem-to-guide clearance). This must be done with the valve installed in its guide and just off the valve seat (Fig. 9).

(2) Correct clearance is 0.025-0.0762 mm (0.001-0.003 inch). If indicated movement exceeds the specification ream the valve guide to accommodate an oversize valve stem.

Valve seats must be ground after reaming the valve guides to ensure that the valve seat is concentric to the valve guide.

VALVE SPRING TENSION TEST

Use Valve Spring Tester C-647 and a torque wrench to test each valve spring for the specified tension value (Fig. 10).

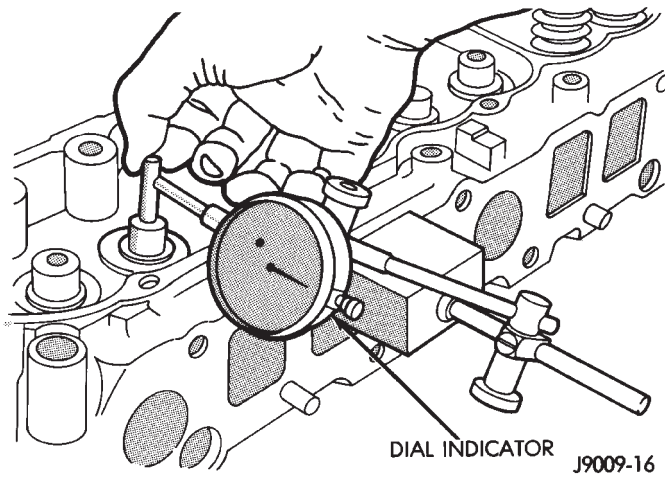

Fig. 9 Measurement of Lateral Movement of Valve Stem

Replace valve springs that are not within specifications.

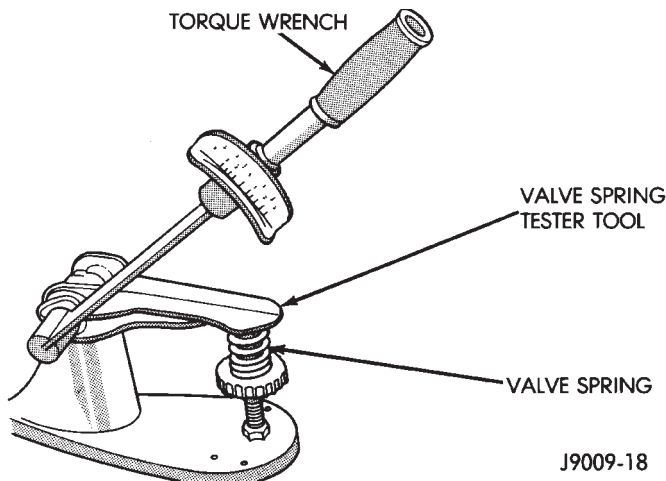

Fig. 10 Valve Spring Tester C-647

INSTALLATION

- (1) Thoroughly clean the valve stems and the valve guide bores.
- (2) Lightly lubricate the stem.
- (3) Install the valve in the original valve guide bore.
- (4) Install the replacement valve stem oil seals on the valve stems. If the 0.381 mm (0.015 inch) oversize valve stems are used, oversize oil seals are required.
- (5) Position the valve spring and retainer on the engine cylinder head and compress the valve spring with Valve Spring Compressor Tool MD-998772A.
- (6) Install the valve locks and release the tool.
- (7) Tap the valve spring from side to side with a hammer to ensure that the spring is properly seated at the engine cylinder head. Also tap the top of the retainer to seat the valve locks.
- (8) Install the engine cylinder head.

HYDRAULIC TAPPETS

Retain all the components in the same order as removed.

REMOVAL

- (1) Remove the engine cylinder head cover.
- (2) Remove the bridge and pivot assemblies and rocker arms by removing the capscrews at each bridge. Alternately loosen each capscrew, one turn at a time, to avoid damaging the bridges.
- (3) Remove the push rods.
- (4) Remove the intake and engine exhaust manifolds (refer to Group 11, Exhaust System and Intake Manifold for the proper procedure).
- (5) Remove the engine cylinder head and gasket.
- (6) Remove the tappets through the push rod openings in the cylinder block with Hydraulic Valve Tappet Removal/Installation Tool C-4129-A (Fig. 11).

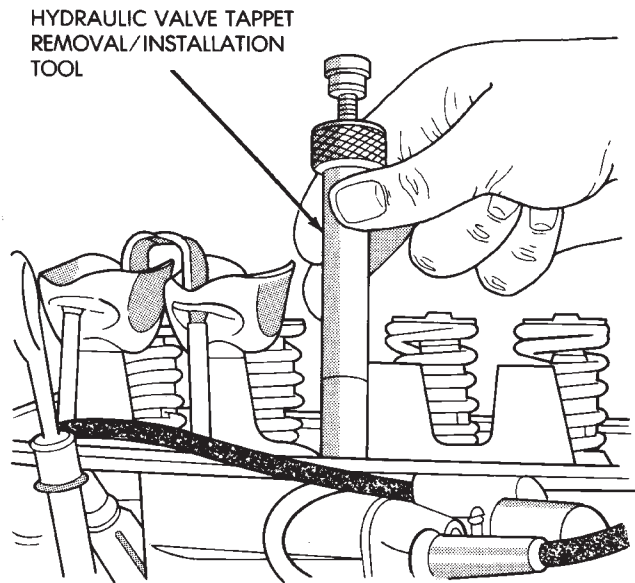

Fig. 11 Hydraulic Valve Tappet Removal/Installation Tool C-4129-A

CLEANING

Clean each tappet assembly in cleaning solvent to remove all varnish, gum and sludge deposits.

INSPECTION

Inspect for indications of scuffing on the side and base of each tappet body.

Inspect each tappet base for concave wear with a straightedge positioned across the base. If the base is concave, the corresponding lobe on the camshaft is also worn. Replace the camshaft and defective tappets.

LEAK-DOWN TEST

After cleaning and inspection, test each tappet for specified leak-down rate tolerance to ensure zero-lash operation (Fig. 12).

Swing the weighted arm of the hydraulic valve tappet tester away from the ram of the Leak-Down Tester 7980.

(1) Place a 7.925-7.950 mm (0.312-0.313 inch) diameter ball bearing on the plunger cap of the tappet.

(2) Lift the ram and position the tappet (with the ball bearing) inside the tester cup.

(3) Lower the ram, then adjust the nose of the ram until it contacts the ball bearing. DO NOT tighten the hex nut on the ram.

(4) Fill the tester cup with hydraulic valve tappet test oil until the tappet is completely submerged.

(5) Swing the weighted arm onto the push rod and pump the tappet plunger up and down to remove air. When the air bubbles cease, swing the weighted arm away and allow the plunger to rise to the normal position.

(6) Adjust the nose of the ram to align the pointer with the SET mark on the scale of the tester and tighten the hex nut.

(7) Slowly swing the weighted arm onto the push rod.

(8) Rotate the cup by turning the handle at the base of the tester clockwise one revolution every 2 seconds.

(9) Observe the leak-down time interval from the instant the pointer aligns with the START mark on the scale until the pointer aligns with the 0.125 mark. A normally functioning tappet will require 20-110 seconds to leak-down. Discard tappets with leak-down time interval not within this specification.

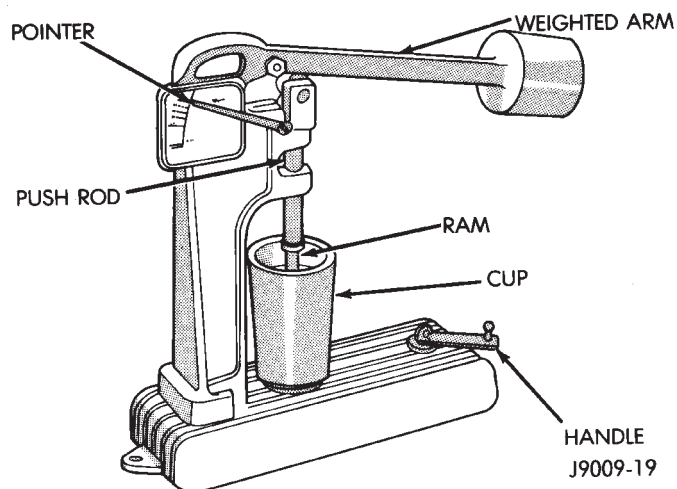

Fig. 12 Leak-Down Tester 7980

INSTALLATION

It is not necessary to charge the tappets with engine oil. They will charge themselves within a very short period of engine operation.

(1) Dip each tappet in Mopar Engine Oil Supplement, or equivalent.

(2) Use Hydraulic Valve Tappet Removal/Installation Tool C-4129-A to install each tappet in the same bore from where it was originally removed.

(3) Install the exhaust and intake manifolds (refer to Group 11, Exhaust System and Intake Manifold for the proper procedure).

(4) Install the engine cylinder head and gasket.

(5) Install the push rods in their original locations.

(6) Install the rocker arms and bridge and pivot assemblies at their original locations. Loosely install the capscrews at each bridge.

(7) Tighten the capscrews alternately, one turn at a time, to avoid damaging the bridges. Tighten the capscrews to 28 N·m (21 ft. lbs.) torque.

(8) Pour the remaining Mopar Engine Oil Supplement, or equivalent over the entire valve actuating assembly. The Mopar Engine Oil Supplement, or equivalent must remain with the engine oil for at least 1 609 km (1,000 miles). The oil supplement need not be drained until the next scheduled oil change.

(9) Install the engine cylinder head cover.

VALVE TIMING

Disconnect the spark plug wires and remove the spark plugs.

Remove the engine cylinder head cover.

Remove the capscrews, bridge and pivot assembly, and rocker arms from above the No.1 cylinder.

Alternately loosen each capscrew, one turn at a time, to avoid damaging the bridge.

Rotate the crankshaft until the No.6 piston is at top dead center (TDC) on the compression stroke.

Rotate the crankshaft counterclockwise (viewed from the front of the engine) 90°.

Install a dial indicator on the end of the No.1 cylinder intake valve push rod. Use rubber tubing to secure the indicator stem on the push rod.

Set the dial indicator pointer at zero.

Rotate the crankshaft clockwise (viewed from the front of the engine) until the dial indicator pointer indicates 0.305 mm (0.012 inch) travel distance (lift).

The timing notch index on the vibration damper should be aligned with the TDC mark on the timing degree scale.

If the timing notch is more than 13 mm (1/2 inch) away from the TDC mark in either direction, the valve timing is incorrect.

If the valve timing is incorrect, the cause may be a broken camshaft pin. It is not necessary to replace the camshaft because of pin failure. A spring pin is available for service replacement.

VIBRATION DAMPER

REMOVAL

- (1) Disconnect negative cable from battery.
- (2) Remove the serpentine drive belt and fan shroud.
- (3) Remove the vibration damper retaining bolt and washer.
- (4) Use Vibration Damper Removal Tool 8068 to remove the damper from the crankshaft (Fig. 1).

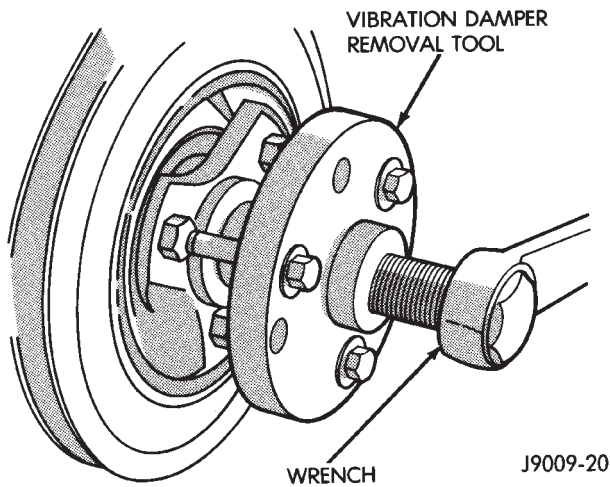

Fig. 1 Vibration Damper Removal Tool 8068

INSTALLATION

- (1) Apply Mopar Silicone Rubber Adhesive Sealant to the keyway in the crankshaft and insert the key. With the key in position, align the keyway on the vibration damper hub with the crankshaft key and tap the damper onto the crankshaft.
- (2) Install the vibration damper retaining bolt and washer.
- (3) Tighten the damper retaining bolt to 108 N·m (80 ft. lbs.) torque.
- (4) Install the serpentine drive belt and tighten to the specified tension (refer to Group 7, Cooling Systems for the proper specifications and procedures).
- (5) Connect negative cable to battery.

TIMING CASE COVER OIL SEAL REPLACEMENT

This procedure is done with the timing case cover installed.

- (1) Disconnect negative cable from battery.
- (2) Remove the serpentine drive belt.
- (3) Remove the vibration damper.
- (4) Remove the radiator shroud.
- (5) Carefully remove the oil seal (Fig. 2). Make sure seal bore is clean.
- (6) Position the replacement oil seal on Timing Case Cover Alignment and Seal Installation Tool 6139 with seal open end facing inward. Apply a light film of Perfect Seal, or equivalent, on the outside diameter of the seal. Lightly coat the crankshaft with engine oil.

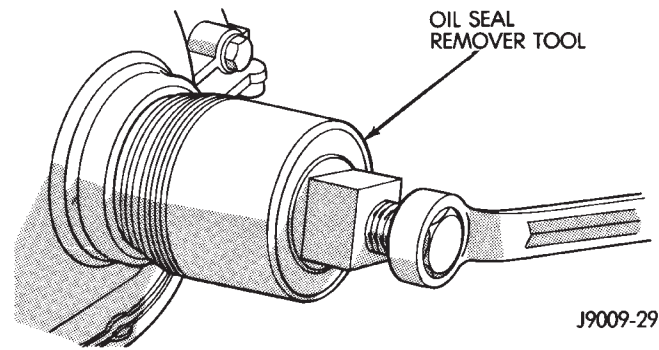

Fig. 2 Timing Case Cover Oil Seal Removal

- (7) Position the tool and seal over the end of the crankshaft and insert a draw screw tool into Seal Installation Tool 6139 (Fig. 3). Tighten the nut against the tool until it contacts the cover.

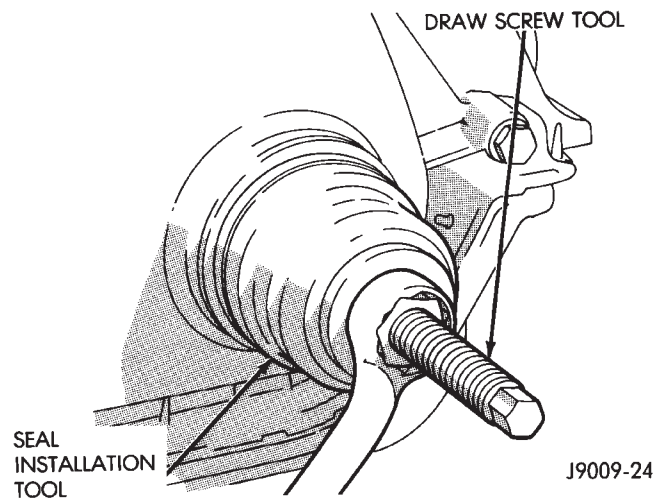

Fig. 3 Timing Case Cover Oil Seal Installation

- (8) Remove the tools. Apply a light film of engine oil on the vibration damper hub contact surface of the seal.
- (9) Apply Mopar Silicone Rubber Adhesive Sealant to the keyway in the crankshaft and insert the key. With the key inserted in the keyway in the crankshaft, install the vibration damper, washer and bolt. Lubricate and tighten the bolt to 108 N·m (80 ft. lbs.) torque.
- (10) Install the serpentine belt and tighten to the specified tension (refer to Group 7, Cooling Systems for the proper specifications and procedures).
- (11) Install the radiator shroud.
- (12) Connect negative cable to battery.

TIMING CASE COVER

REMOVAL

- (1) Disconnect negative cable from battery.
- (2) Remove the vibration damper (Fig. 4).
- (3) Remove the fan and hub assembly and remove the fan shroud.

(4) Remove the accessory drive brackets that are attached to the timing case cover.

(5) Remove the A/C compressor (if equipped) and generator bracket assembly from the engine cylinder head and move to one side.

(6) Remove the oil pan-to-timing case cover bolts and timing case cover-to-cylinder block bolts.

(7) Remove the timing case cover and gasket from the engine. Make sure the tension spring and thrust pin do not fall out of the preload bolt.

(8) Pry the crankshaft oil seal from the front of the timing case cover (Fig. 4).

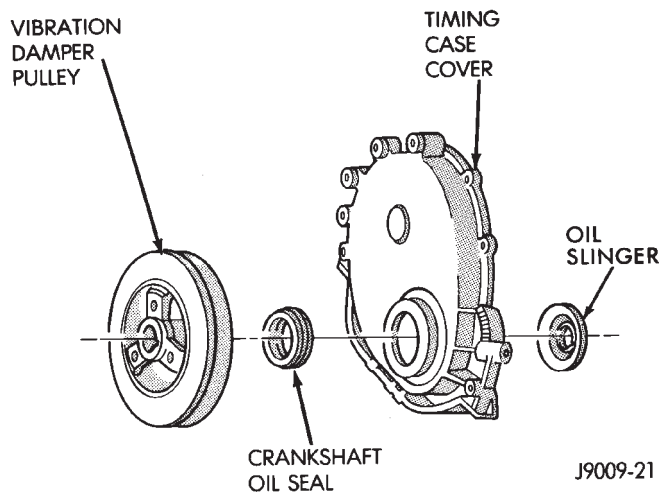

Fig. 4 Timing Case Cover Components

CLEANING

Clean the timing case cover, oil pan and cylinder block gasket surfaces.

INSTALLATION

(1) Install a new crankshaft oil seal in the timing case cover. The open end of the seal should be toward the inside of the cover. Support the cover at the seal area while installing the seal. Force it into position with Seal Installation Tool 6139.

(2) Position the gasket on the cylinder block.

(3) Position the timing case cover on the oil pan gasket and the cylinder block. Make sure the tension spring and thrust pin are in place in the camshaft preload bolt.

(4) Insert Timing Case Cover Alignment and Seal Installation Tool 6139 in the crankshaft opening in the cover (Fig. 5).

(5) Install the timing case cover-to-cylinder block and the oil pan-to-timing case cover bolts.

(6) Tighten the 1/4 inch cover-to-block bolts to 7 N·m (60 in. lbs.) torque. Tighten the 5/16 inch front cover-to-block bolts to 22 N·m (192 in. lbs.) torque. Tighten the oil pan-to-cover 1/4 inch bolts to 14 N·m (120 in. lbs.) torque. Tighten the oil pan-to-cover 5/16 inch bolts to 18 N·m (156 in. lbs.) torque.

(7) Remove the cover alignment tool.

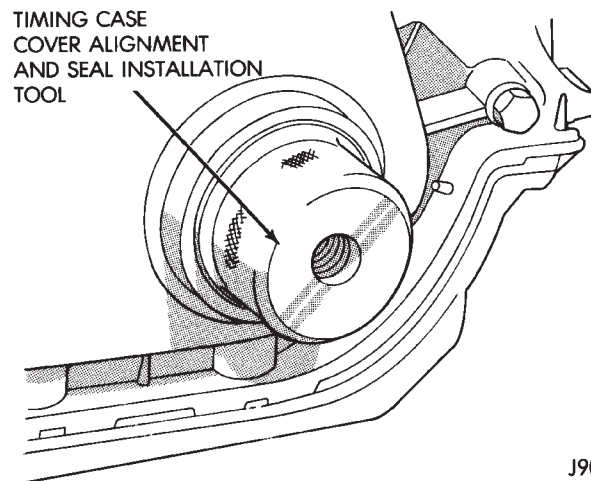

Fig. 5 Timing Case Cover Alignment and Seal Installation Tool 6139

(8) Apply a light film of engine oil on the vibration damper hub contact surface of the seal.

(9) Apply Mopar Silicone Rubber Adhesive Sealant to the keyway in the crankshaft and insert the key. With the key inserted in the keyway in the crankshaft, install the vibration damper, washer and bolt. Lubricate and tighten the bolt to 108 N·m (80 ft. lbs.) torque.

(10) Install the A/C compressor (if equipped) and generator bracket assembly.

(11) Install the engine fan and hub assembly and shroud.

(12) Install the serpentine drive belt and tighten to obtain the specified tension.

(13) Connect negative cable to battery.

TIMING CHAIN AND SPROCKETS

REMOVAL

(1) Disconnect negative cable from battery.

(2) Remove the fan and shroud.

(3) Remove the serpentine drive belt.

(4) Remove the crankshaft vibration damper.

(5) Remove the timing case cover.

(6) Rotate crankshaft until the "0" timing mark is closest to and on the center line with camshaft sprocket timing mark (Fig. 6).

(7) Remove the oil slinger from the crankshaft.

(8) Remove the tension spring and thrust pin from the preload bolt (Fig. 7). Remove the camshaft sprocket retaining preload bolt and washer.

(9) Remove the crankshaft sprocket, camshaft sprocket and timing chain as an assembly.

Installation of the timing chain with the timing marks on the crankshaft and camshaft sprockets properly aligned ensures correct valve timing. A worn or stretched timing chain will adversely affect valve timing. If the timing chain deflects more than

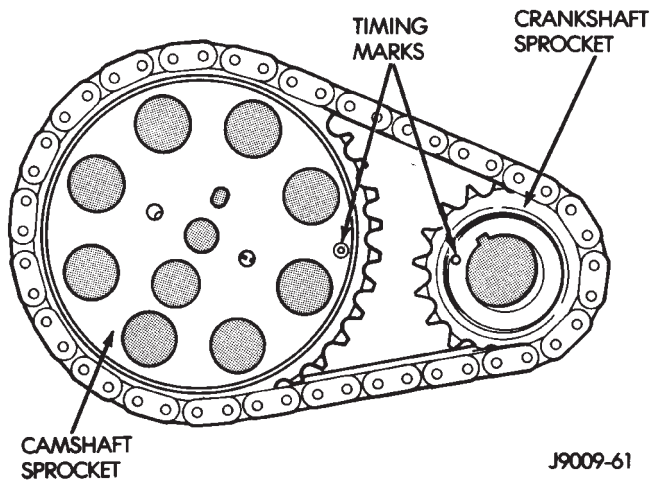

Fig. 6 Crankshaft/Camshaft Alignment—Typical

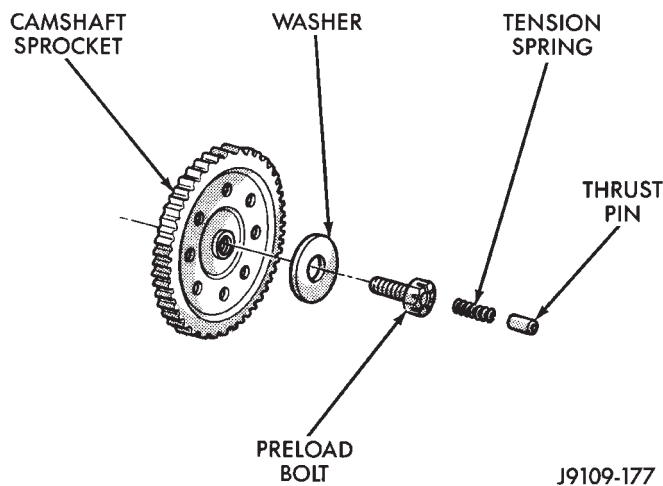

Fig. 7 Camshaft Sprocket Preload Bolt

12.7 mm (1/2 inch) replace it. The correct timing chain has 48 pins. A chain with more than 48 pins will cause excessive slack.

INSTALLATION

Assemble the timing chain, crankshaft sprocket and camshaft sprocket with the timing marks aligned (Fig. 6).

(1) Apply Mopar Silicone Rubber Adhesive Sealant to the keyway in the crankshaft and insert the key. With the key in the keyway on the crankshaft, install the assembly on the crankshaft and camshaft.

(2) Install the camshaft sprocket retaining preload bolt and washer (Fig. 7). Tighten the preload bolt to 108 N·m (80 ft. lbs.) torque.

(3) To verify correct installation of the timing chain, turn the crankshaft to position the camshaft sprocket timing mark as shown in Fig. 8. Count the number of chain pins between the timing marks of both sprockets. There must be 15 pins.

(4) Install the crankshaft oil slinger.

(5) Replace the oil seal in the timing case cover.

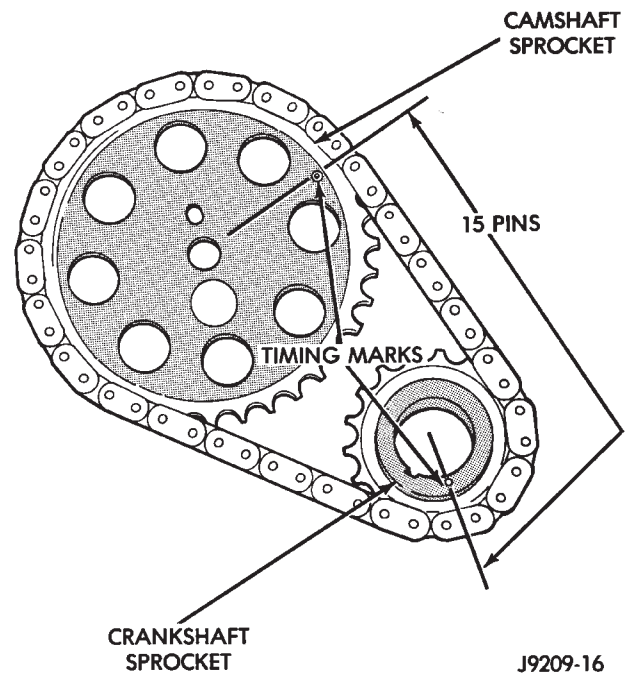

Fig. 8 Verify Sprocket/Chain Installation—Typical

(6) Lubricate the tension spring, thrust pin and pin bore in the preload bolt with Mopar Engine Oil Supplement, or equivalent. Install the spring and thrust pin in the preload bolt head (Fig. 6).

(7) Install the timing case cover and gasket.

(8) With the key installed in the crankshaft keyway, install the vibration damper, washer and bolt. Lubricate and tighten the bolt to 108 N·m (80 ft. lbs.) torque.

(9) Install the serpentine drive belt and tighten to the specified tension (refer to Group 7, Cooling System for the proper procedure).

(10) Install the fan and hub (or Tempatrol fan) assembly. Install the shroud.

(11) Connect negative cable to battery.

CAMSHAFT

REMOVAL

WARNING: THE COOLANT IN A RECENTLY OPERATED ENGINE IS HOT AND PRESSURIZED. RELEASE THE PRESSURE BEFORE REMOVING THE DRAIN COCK, CAP AND DRAIN PLUGS.

(1) Disconnect negative cable from battery.

(2) Drain the cooling system. DO NOT waste reusable coolant. If the solution is clean, drain it into a clean container for reuse.

(3) Remove the radiator or radiator/condenser, if equipped with A/C (refer to Group 7, Cooling System for the proper procedure).

(4) Remove the air conditioner condenser and receiver/drier assembly as a charged unit, if equipped (refer to Group 24, Heating and Air Conditioning).

- (5) Remove the distributor cap and mark the position of the rotor.
- (6) Remove the distributor and ignition wires.
- (7) Remove the engine cylinder head cover.
- (8) Remove the rocker arms, bridges and pivots.
- (9) Remove the push rods.
- (10) Remove the engine cylinder head and gasket.
- (11) Remove the hydraulic valve tappets from the engine cylinder head.
- (12) Remove the vibration damper.
- (13) Remove the timing case cover.
- (14) Remove the timing chain and sprockets.
- (15) Remove the front bumper and/or grille, as required.
- (16) Remove the camshaft (Fig. 9).

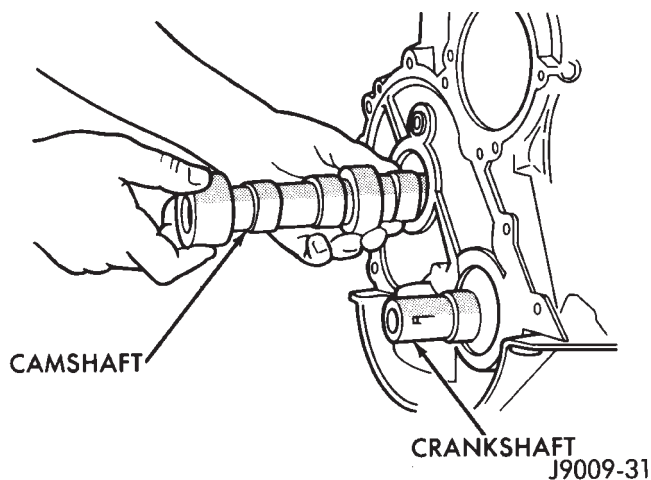

Fig. 9 Camshaft

INSPECTION

- Inspect the cam lobes for wear.
- Inspect the bearing journals for uneven wear pattern or finish.
- Inspect the bearings for wear.
- Inspect the distributor drive gear for wear.
- If the camshaft appears to have been rubbing against the timing case cover, examine the oil pressure relief holes in the rear cam journal. The oil pressure relief holes must be free of debris.

INSTALLATION

- (1) Lubricate the camshaft with Mopar Engine Oil Supplement, or equivalent.
- (2) Carefully install the camshaft to prevent damage to the camshaft bearings (Fig. 9).
- (3) Install the timing chain, crankshaft sprocket and camshaft sprocket with the timing marks aligned.
- (4) Install the camshaft sprocket retaining preload bolt. Tighten the bolt to 108 N·m (80 ft. lbs.) torque.
- (5) Lubricate the tension spring, the thrust pin and the pin bore in the preload bolt with Mopar Engine Oil Supplement, or equivalent. Install the spring and thrust pin in the preload bolt head.

- (6) Install the timing case cover with a replacement oil seal (Fig. 10). Refer to Timing Case Cover Installation.
- (7) Install the vibration damper (Fig. 10).

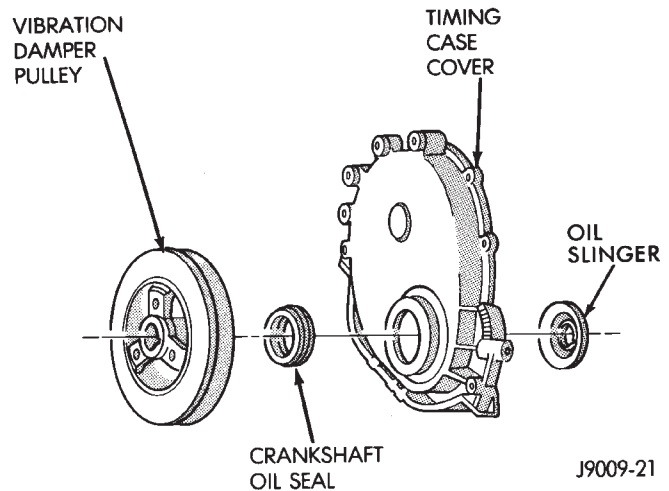

Fig. 10 Timing Case Cover Components

- (8) Install the hydraulic valve tappets.
 - (9) Install the engine cylinder head.
 - (10) Install the push rods.
 - (11) Install the rocker arms and pivot and bridge assemblies. Tighten each of the capscrews for each bridge alternately, one turn at a time, to avoid damaging the bridge.
 - (12) Install the engine cylinder head cover.
 - (13) Install the serpentine drive belt and tighten to the specified tension (refer to Group 7, Cooling System for the proper procedure).
 - (14) Rotate the crankshaft until the No.1 piston is at the TDC position on the compression stroke.
 - (15) Install the distributor, cap and ignition wires. Install the distributor so that the rotor is aligned with the mark made during removal. The rotor should be aligned with the No.1 cylinder spark plug terminal on the cap when the distributor housing is fully seated on the cylinder block.
- During installation, lubricate the hydraulic valve tappets and all valve components with Mopar Engine Oil Supplement, or equivalent. The Mopar Engine Oil Supplement, or equivalent must remain with the engine oil for at least 1 609 km (1,000 miles). The oil supplement need not be drained until the next scheduled oil change.**
- (16) Install the A/C condenser and receiver/drier assembly, if equipped (refer to Group 24, Heating and Air Conditioning).

CAUTION: Both service valves must be opened before the air conditioning system is operated.

- (17) Install the radiator, connect the hoses and fill the cooling system to the specified level (refer to Group 7, Cooling System for the proper procedure).

- (18) Check the ignition timing and adjust as necessary.
- (19) Install the grille and bumper, if removed.
- (20) Connect negative cable to battery.

CAMSHAFT PIN REPLACEMENT

REMOVAL

WARNING: DO NOT LOOSEN THE RADIATOR DRAIN COCK WITH THE SYSTEM HOT AND PRESSURIZED BECAUSE SERIOUS BURNS FROM COOLANT CAN OCCUR.

- (1) Disconnect negative cable from battery.
- (2) Drain the radiator. **DO NOT** waste reusable coolant. Drain the coolant into a clean container.
- (3) Remove the fan and shroud.
- (4) Disconnect the radiator overflow tube, radiator hoses, automatic transmission fluid cooler pipes (if equipped).
- (5) Remove the radiator.
- (6) If equipped with air conditioning:

CAUTION: DO NOT loosen or disconnect any air conditioner system fittings. Move the condenser and receiver/drier aside as a complete assembly.

- (a) Remove the A/C compressor serpentine drive belt idler pulley.
- (b) Disconnect and remove the generator.
- (c) Remove the A/C condenser attaching bolts and move the condenser and receiver/drier assembly up and out of the way.
- (7) Remove the serpentine drive belt.
- (8) Remove the crankshaft vibration damper.
- (9) Remove the timing case cover. Clean the gasket material from the cover.
- (10) Remove the thrust pin and tension spring from the preload bolt head.
- (11) Rotate crankshaft until the crankshaft sprocket timing mark is closest to and on the center line with the camshaft sprocket timing mark (Fig. 11).
- (12) Remove the camshaft sprocket preload retaining bolt and washer.
- (13) Remove the crankshaft oil slinger.
- (14) Remove the sprockets and chain as an assembly.

CAUTION: The following procedural step must be accomplished to prevent the camshaft from damaging the rear camshaft plug during pin installation.

- (15) Inspect the damaged camshaft pin.
- (16) If the pin is a spring-type pin, remove the broken pin by inserting a self-tapping screw into the pin and carefully pulling the pin from the camshaft.

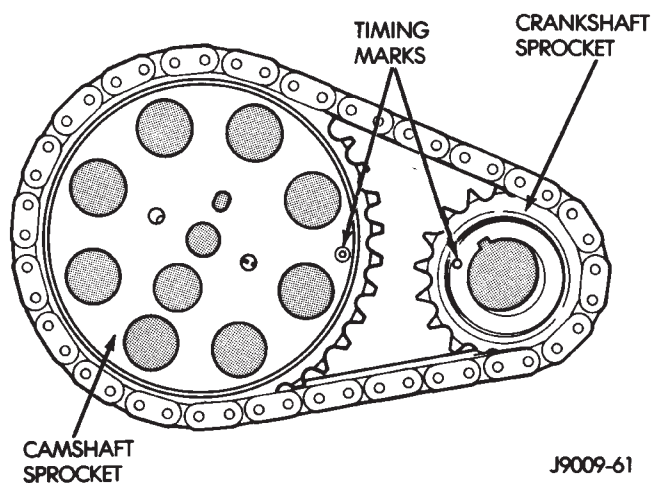

Fig. 11 Timing Chain Alignment—Typical

- (17) If the pin is a dowel-type pin, center-punch it. Ensure the exact center is located when center-punching the pin.

CAUTION: Cover the opened oil pan area to prevent metal chips from entering the pan.

- (18) Drill into the pin center with a 4 mm (5/32 inch) drill bit.

- (19) Insert a self-tapping screw into the drilled pin and carefully pull the pin from the camshaft.

CAMSHAFT BEARINGS

The camshaft rotates within four steel-shelled, babbit-lined bearings that are pressed into the cylinder block and then line reamed. The camshaft bearing bores and bearing diameters are not the same size. They are stepped down in 0.254 mm (0.010 inch) increments from the front bearing (largest) to the rear bearing (smallest). This permits easier removal and installation of the camshaft. The camshaft bearings are pressure lubricated.

It is not advisable to attempt to replace camshaft bearings unless special removal and installation tools are available.

Camshaft end play is maintained by the load placed on the camshaft by the sprocket preload bolt tension spring and thrust pin.

INSTALLATION

- (1) Clean the camshaft pin hole.
- (2) Compress the center of the replacement spring pin with vise grips.
- (3) Carefully drive the pin into the camshaft pin hole until it is seated.
- (4) Install the camshaft sprocket, crankshaft sprocket and timing chain with the timing marks aligned (Fig. 11).
- (5) To verify correct installation of the timing chain, turn the crankshaft to position the camshaft sprocket timing mark as shown in Fig. 12. Count the

number of chain pins between the timing marks of both sprockets. There must be 15 pins.

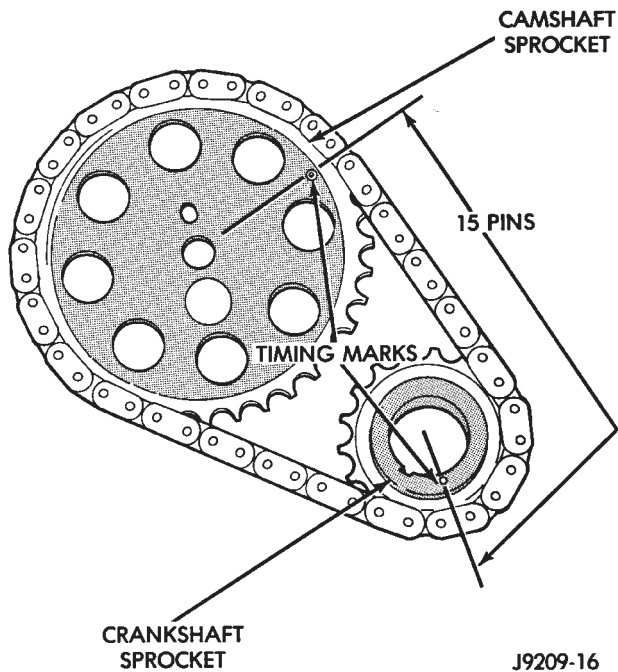
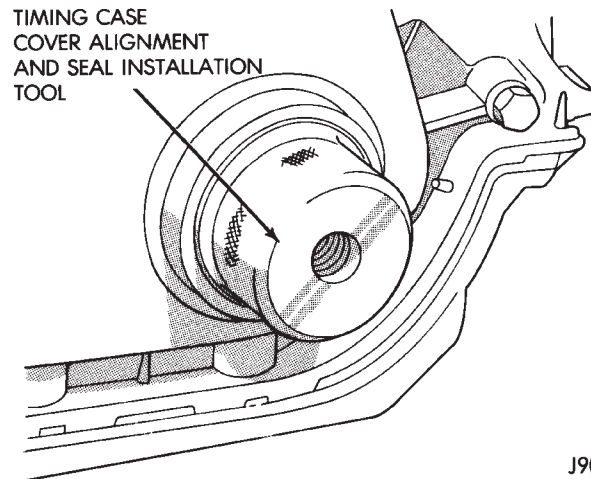

Fig. 12 Verify Crankshaft/Camshaft Installation—Typical

- (6) Install the crankshaft oil slinger.
- (7) Tighten the camshaft sprocket preload bolt to 108 N·m (80 ft. lbs.) torque.
- (8) Check the valve timing.
- (9) Lubricate the tension spring, the thrust pin and the pin bore in the preload bolt with Mopar Engine Oil Supplement, or equivalent. Install the spring and thrust pin in the preload bolt head.
- (10) Coat both sides of the replacement timing case cover gasket with gasket sealer. Apply a 3 mm (1/8 inch) bead of Mopar Silicone Rubber Adhesive Sealant, or equivalent to the joint formed at the oil pan and cylinder block.
- (11) Position the timing case cover on the oil pan gasket and the cylinder block.
- (12) Place Timing Case Cover Alignment and Seal Installation Tool 6139 in the crankshaft opening in the cover (Fig. 13).
- (13) Install the timing case cover-to-cylinder block bolts. Install the oil pan-to-timing case cover bolts.
- (14) Tighten the 1/4 inch cover-to-block bolts to 7 N·m (60 in. lbs.) torque. Tighten the 5/16 inch front cover-to-block bolts to 22 N·m (192 in. lbs.) torque. Tighten the oil pan-to-cover 1/4 inch bolts to 14 N·m (120 in. lbs.) torque. Tighten the oil pan-to-cover 5/16 inch bolts to 18 N·m (156 in. lbs.) torque.
- (15) Remove the cover alignment tool and install a replacement oil seal into the cover.
- (16) Install the vibration damper on the crankshaft.



J9009-23

Fig. 13 Timing Case Cover Alignment and Seal Installation Tool 6139

- (17) Lubricate and tighten the damper bolt to 108 N·m (80 ft. lbs.) torque.
- (18) If equipped with air conditioning:
 - (a) Install the A/C compressor serpentine drive belt idler pulley.
 - (b) Install the generator.
 - (c) Install the A/C condenser and receiver/drier assembly.
- (19) Install the serpentine drive belt on the pulleys and tighten (refer to Group 7, Cooling System for the specifications and procedures).
- (20) Install the radiator. Connect the radiator hoses and automatic transmission fluid cooler pipes, if equipped. Fill the cooling system.
- (21) Install the fan and shroud.
- (22) Connect negative cable to battery.

OIL PAN

REMOVAL

- (1) Disconnect negative cable from battery.
- (2) Raise the vehicle.
- (3) Remove the oil pan drain plug and drain the engine oil.
- (4) Disconnect the exhaust pipe at the exhaust manifold.
- (5) Disconnect the exhaust hanger at the catalytic converter and lower the pipe.
- (6) Remove the starter motor.
- (7) Remove the engine flywheel/transmission torque converter housing access cover.
- (8) If equipped with an oil level sensor, disconnect the sensor.
- (9) Position a jack stand directly under the engine vibration damper.
- (10) Place a piece of wood (2 x 2) between the jack stand and the engine vibration damper.
- (11) Remove the engine mount through bolts.

(12) Using the jack stand, raise the engine until adequate clearance is obtained to remove the oil pan.

(13) Remove the oil pan bolts. Carefully slide the oil pan and gasket to the rear. If equipped with an oil level sensor, take care not to damage the sensor.

CLEANING

Clean the block and pan gasket surfaces.

INSTALLATION

(1) Fabricate 4 alignment dowels from 1 1/2 x 1/4 inch bolts. Cut the head off the bolts and cut a slot into the top of the dowel. This will allow easier installation and removal with a screwdriver (Fig. 1).

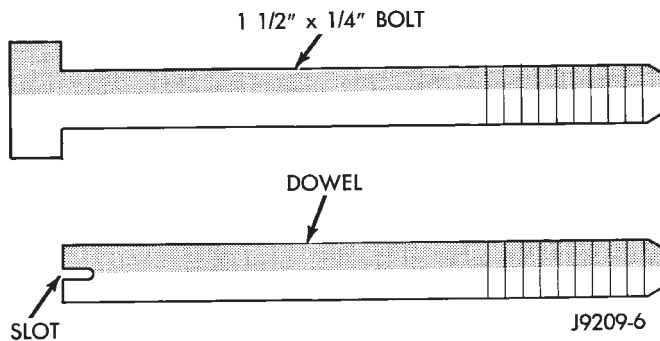

Fig. 1 Fabrication of Alignment Dowels

(2) Install two dowels in the timing case cover. Install the other two dowels in the cylinder block (Fig. 2).

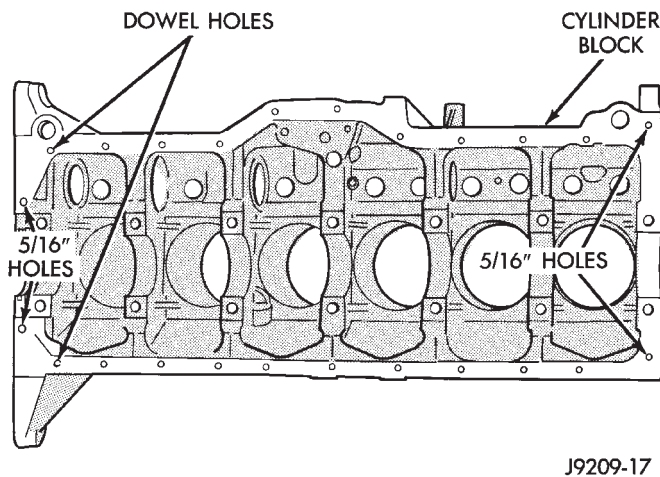

Fig. 2 Position of Dowels in Cylinder Block

(3) Slide the one-piece gasket over the dowels and onto the block and timing case cover.

(4) Position the oil pan over the dowels and onto the gasket. If equipped with an oil level sensor, take care not to damage the sensor.

(5) Install the 1/4 inch oil pan bolts. Tighten these bolts to 14 N·m (120 in. lbs.) torque. Install the 5/16 inch oil pan bolts (Fig. 3). Tighten these bolts to 18 N·m (156 in. lbs.) torque.

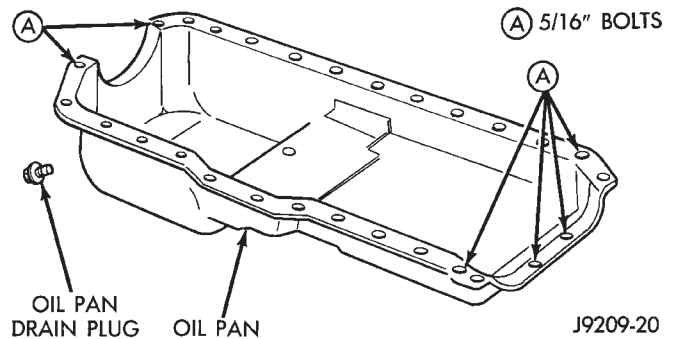

Fig. 3 Position of 5/16 inch Oil Pan Bolts

(6) Remove the dowels. Install the remaining 1/4 inch oil pan bolts. Tighten these bolts to 14 N·m (120 in. lbs.) torque.

(7) Lower the engine until it is properly located on the engine mounts.

(8) Install the through bolts and tighten the nuts.

(9) Lower the jack stand and remove the piece of wood.

(10) If equipped with an oil level sensor, connect the sensor.

(11) Install the engine flywheel/transmission torque converter housing access cover.

(12) Install the engine starter motor.

(13) Connect the exhaust pipe to the hanger and to the engine exhaust manifold.

(14) Install the oil pan drain plug (Fig. 3). Tighten the plug to 34 N·m (25 ft. lbs.) torque.

(15) Lower the vehicle.

(16) Connect negative cable to battery.

(17) Fill the oil pan with engine oil to the specified level.

WARNING: USE EXTREME CAUTION WHEN THE ENGINE IS OPERATING. DO NOT STAND IN A DIRECT LINE WITH THE FAN. DO NOT PUT YOUR HANDS NEAR THE PULLEYS, BELTS OR FAN. DO NOT WEAR LOOSE CLOTHING.

(18) Start the engine and inspect for leaks.

OIL PUMP

A gear-type oil pump is mounted at the underside of the cylinder block opposite the No.4 main bearing.

The pump incorporates a nonadjustable pressure relief valve to limit maximum pressure to 517 kPa (75 psi). In the relief position, the valve permits oil to bypass through a passage in the pump body to the inlet side of the pump.

Oil pump removal or replacement will not affect the distributor timing because the distributor drive gear remains in mesh with the camshaft gear.

REMOVAL

(1) Drain the engine oil.

(2) Remove the oil pan.

(3) Remove the pump-to-cylinder block attaching bolts. Remove the pump assembly with gasket (Fig. 4).

CAUTION: If the oil pump is not to be serviced, DO NOT disturb position of oil inlet tube and strainer assembly in pump body. If the tube is moved within the pump body, a replacement tube and strainer assembly must be installed to assure an airtight seal.

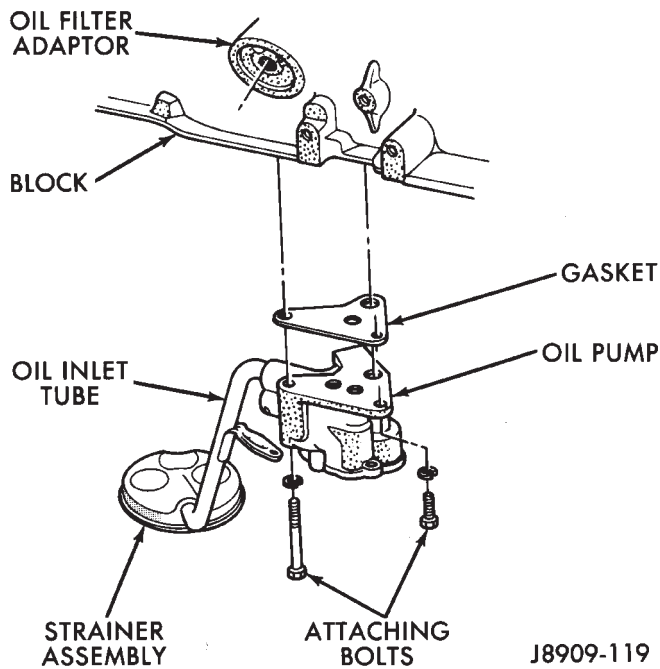

Fig. 4 Oil Pump Assembly

INSTALLATION

- (1) Install the oil pump on the cylinder block using a replacement gasket. Tighten the short bolt to 14 N·m (10 ft. lbs.) torque and the long bolt to 23 N·m (17 ft. lbs.) torque.
- (2) Install the oil pan.
- (3) Fill the oil pan with oil to the specified level.

OIL PUMP PRESSURE

The MINIMUM oil pump pressure is 89.6 kPa (13 psi) at 600 rpm. The MAXIMUM oil pump pressure is 255-517 kPa (37-75 psi) at 1600 rpm or more.

PISTONS AND CONNECTING RODS

REMOVAL

- (1) Remove the engine cylinder head cover.
- (2) Remove the rocker arms, bridges and pivots.
- (3) Remove the push rods.
- (4) Remove the engine cylinder head.
- (5) Position the pistons one at a time near the bottom of the stroke. Use a ridge reamer to remove the ridge from the top end of the cylinder walls. Use a protective cloth to collect the cuttings.
- (6) Raise the vehicle.
- (7) Drain the engine oil.
- (8) Remove the oil pan and gasket.

(9) Remove the connecting rod bearing caps and inserts. Mark the caps and rods with the cylinder bore location. The connecting rods and caps are stamped with a two letter combination (Fig. 1).

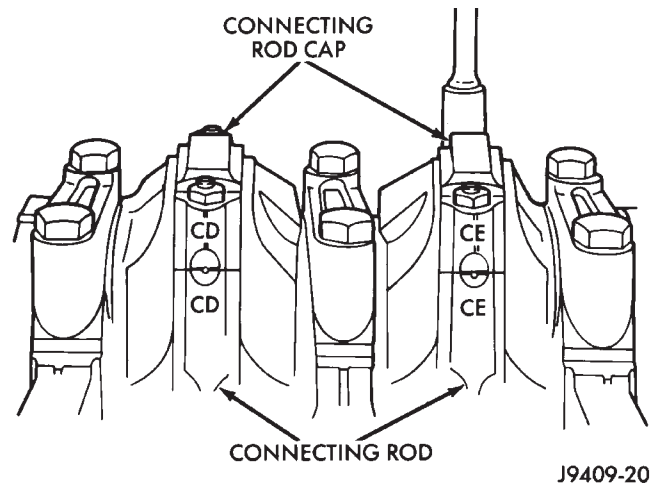

Fig. 1 Stamped Connecting Rods and Caps

(10) Lower the vehicle until it is about 2 feet from the floor.

CAUTION: Ensure that the connecting rod bolts DO NOT scratch the crankshaft journals or cylinder walls. Short pieces of rubber hose, slipped over the rod bolts will provide protection during removal.

(11) Have an assistant push the piston/connecting rod assemblies up and through the top of the cylinder bores (Fig. 2).

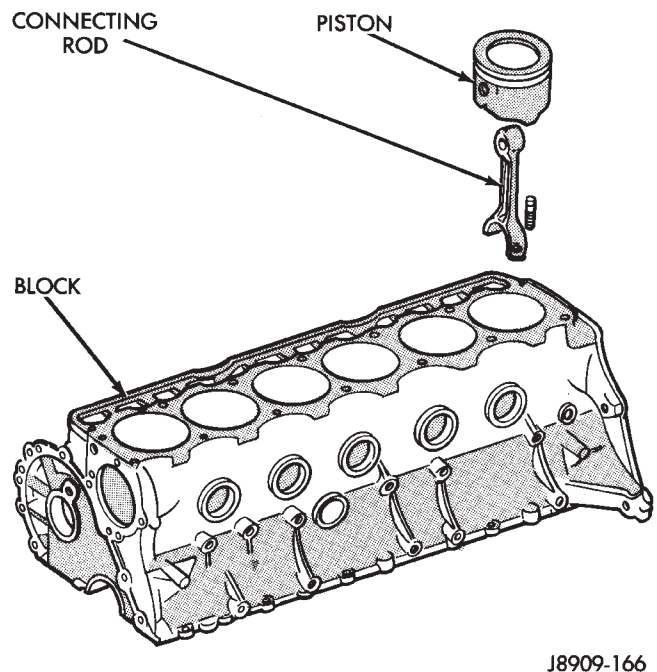

Fig. 2 Removal of Connecting Rod and Piston Assembly

INSPECTION—CONNECTING ROD

CONNECTING ROD BEARINGS

Inspect the connecting rod bearings for scoring and bent alignment tabs (Figs. 3 and 4). Check the bearings for normal wear patterns, scoring, grooving, fatigue and pitting (Fig. 5). Replace any bearing that shows abnormal wear.

Inspect the connecting rod journals for signs of scoring, nicks and burrs.

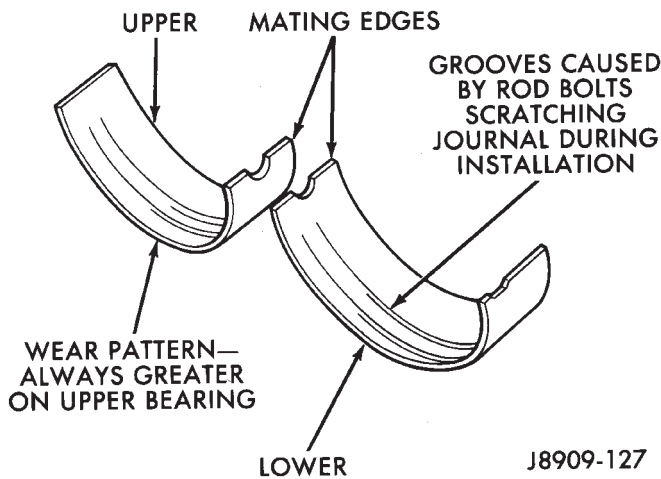

Fig. 3 Connecting Rod Bearing Inspection

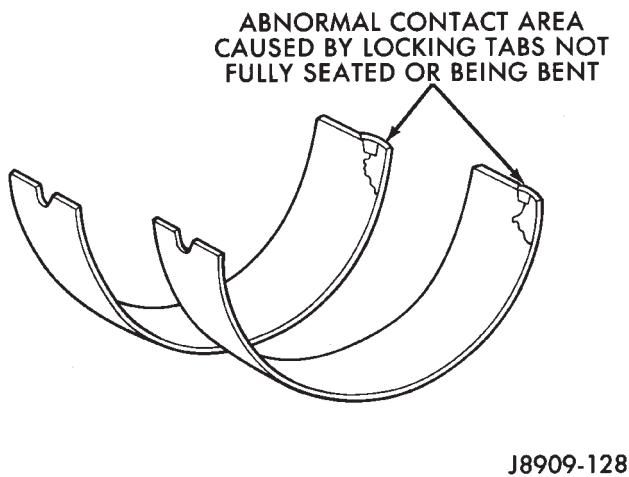

Fig. 4 Locking Tab Inspection

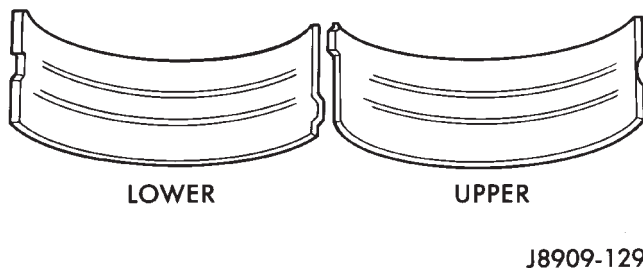

Fig. 5 Scoring Caused by Insufficient Lubrication or by Damaged Crankshaft Pin Journal

CONNECTING RODS

Misaligned or bent connecting rods can cause abnormal wear on pistons, piston rings, cylinder walls, connecting rod bearings and crankshaft connecting rod journals. If wear patterns or damage to any of these components indicate the probability of a misaligned connecting rod, inspect it for correct rod alignment. Replace misaligned, bent or twisted connecting rods.

BEARING-TO-JOURNAL CLEARANCE

- (1) Wipe the oil from the connecting rod journal.
- (2) Use short rubber hose sections over rod bolts during installation.
- (3) Lubricate the upper bearing insert and install in connecting rod.
- (4) Use piston ring compressor to install the rod and piston assemblies. The oil squirt holes in the rods must face the camshaft. The arrow on the piston crown should point to the front of the engine (Fig. 6). Verify that the oil squirt holes in the rods face the camshaft and that the arrows on the pistons face the front of the engine.

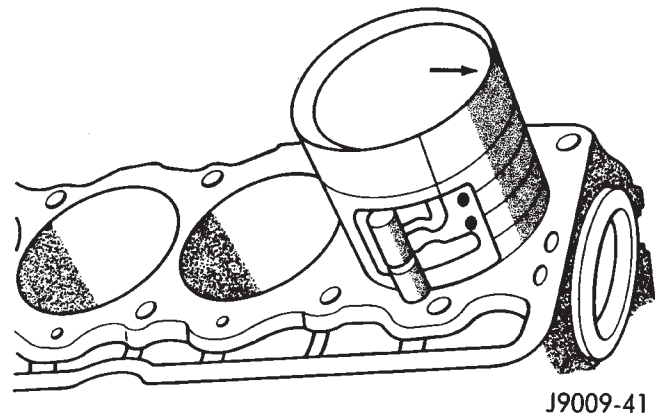

Fig. 6 Rod and Piston Assembly Installation

- (5) Install the lower bearing insert in the bearing cap. The lower insert must be dry. Place strip of Plastigage across full width of the lower insert at the center of bearing cap. Plastigage must not crumble in use. If brittle, obtain fresh stock.

- (6) Install bearing cap and connecting rod on the journal and tighten nuts to 45 N·m (33 ft. lbs.) torque. DO NOT rotate crankshaft. Plastigage will smear, resulting in inaccurate indication.

- (7) Remove the bearing cap and determine amount of bearing-to-journal clearance by measuring the width of compressed Plastigage (Fig. 7). Refer to Engine Specifications for the proper clearance. **Plastigage should indicate the same clearance across the entire width of the insert. If the clearance varies, it may be caused by either a tapered**

journal, bent connecting rod or foreign material trapped between the insert and cap or rod.

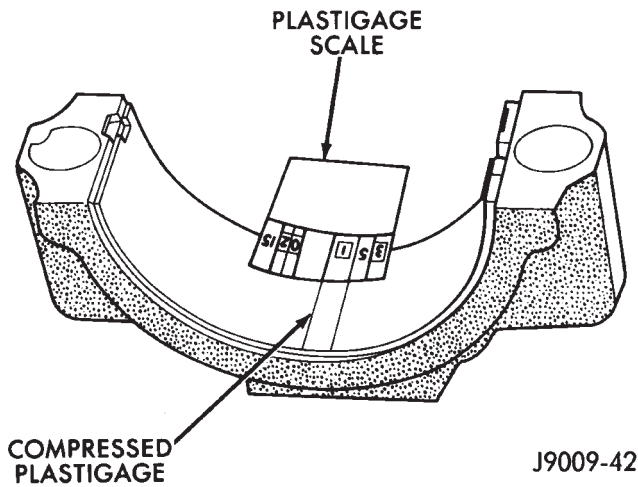

Fig. 7 Measuring Bearing Clearance with Plastigage

(8) If the correct clearance is indicated, replacement of the bearing inserts is not necessary. Remove the Plastigage from crankshaft journal and bearing insert. Proceed with installation.

(9) If bearing-to-journal clearance exceeds the specification, install a pair of 0.0254 mm (0.001 inch) undersize bearing inserts. All the odd size inserts must be on the bottom. The sizes of the service replacement bearing inserts are stamped on the backs of the inserts. Measure the clearance as described in the previous steps.

(10) The clearance is measured with a pair of 0.0254 mm (0.001 inch) undersize bearing inserts in-

stalled. This will determine if two 0.0254 mm (0.001 inch) undersize inserts or another combination is needed to provide the correct clearance (refer to Connecting Rod Bearing Fitting Chart).

FOR EXAMPLE: If the initial clearance was 0.0762 mm (0.003 inch), 0.025 mm (0.001 inch) undersize inserts would reduce the clearance by 0.025 mm (0.001 inch). The clearance would be 0.002 inch and within specification. A 0.051 mm (0.002 inch) undersize insert would reduce the initial clearance an additional 0.013 mm (0.0005 inch). The clearance would then be 0.038 mm (0.0015 inch).

(11) Repeat the Plastigage measurement to verify your bearing selection prior to final assembly.

(12) Once you have selected the proper insert, install the insert and cap. Tighten the connecting rod bolts to 45 N·m (33 ft. lbs.) torque.

SIDE CLEARANCE MEASUREMENT

Slide snug-fitting feeler gauge between the connecting rod and crankshaft journal flange. Refer to Engine Specifications for the proper clearance. Replace the connecting rod if the side clearance is not within specification.

PISTON FITTING

MICROMETER METHOD

(1) Measure the inside diameter of the cylinder bore at a point 58.725 mm (2-5/16 inches) below top of bore.

(2) Measure outside diameter of the piston. Because pistons are cam ground, measure at right angle to piston pin at center line of pin (Fig. 8).

CONNECTING ROD BEARING FITTING CHART

Crankshaft Journal		Corresponding Connecting Rod Bearing Insert	
Color Code	Diameter	Upper Insert Size	Lower Insert Size
Yellow	53.2257-53.2079 mm (2.0955-2.0948 in.)	Yellow - Standard	Yellow - Standard
Orange	53.2079-53.1901 mm (2.0948-2.0941 in.) 0.0178 mm (0.0007 in.) Undersize	Yellow - Standard	Blue - Undersize 0.025 mm (0.001 in.)
Blue	53.1901-53.1724 mm (2.0941-2.0934 in.) 0.0356 mm (0.0014 in.) Undersize	Blue - Undersize 0.025 mm (0.001 in.)	Blue - Undersize 0.025 mm (0.001 in.)
Red	52.9717-52.9539 mm (2.0855-2.0848 in.) 0.254 mm (0.010 in.) Undersize	Red - Undersize 0.254 mm (0.010 in.)	Red - Undersize 0.254 mm (0.010 in.)

The difference between cylinder bore diameter and piston diameter is piston-to-bore clearance.

GROOVE HEIGHT

A	2.0193-2.0447 mm (0.0795-0.0805 in)
B	4.7752-4.8133 mm (0.1880-0.1895 in)

GROOVE DIAMETER

D - E	87.78-87.90 mm (3.456-3.461 in)
F	87.50-87.75 mm (3.445-3.455 in)

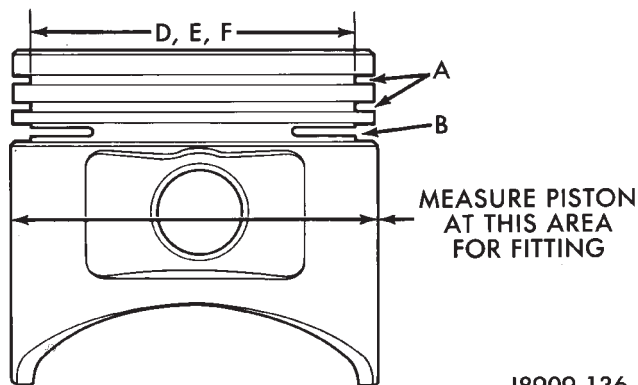

J8909-136

Fig. 8 Piston Dimensions

FEELER GAUGE METHOD

- (1) Remove the rings from the piston.
- (2) Insert a long 0.025 mm (0.001 inch) feeler gauge into the cylinder bore.
- (3) Insert the piston, top first, into cylinder bore alongside the feeler gauge. With entire piston inserted into cylinder bore, the piston should not bind against feeler gauge.
- (4) Repeat steps with a long 0.051 mm (0.002 inch) feeler gauge. The piston should bind.
- (5) If the piston binds on 0.025 mm (0.001 inch) feeler gauge, the piston is too large or cylinder bore is too small. If the piston does not bind on 0.051 mm (0.002 inch) feeler gauge, the piston is too small for cylinder bore. Pistons up to 0.102 mm (0.004 inch) undersize may be enlarged by knurling or shot-peening. Replace pistons that are 0.102 mm (0.004 inch) or more undersize.

PISTON PIN

REMOVAL

Piston pins are press-fitted into the connecting rods and require no locking device.

- (1) Position the piston and connecting rod assembly on an arbor press.
- (2) Apply force to a piloted driver and press the pin completely out of the connecting rod and piston assembly (Fig. 9). Note position of the pin through the gauge window of removal support tool.

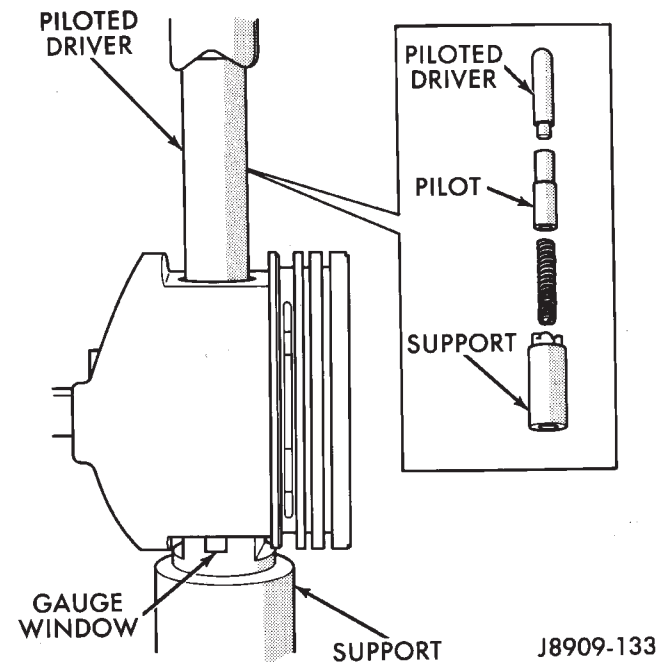

J8909-133

Fig. 9 Piston Pin Removal/Installation

INSPECTION

- (1) Inspect the piston pin and pin bore in the connecting rod for nicks and burrs. Remove as necessary. Never reuse a piston pin after it has been installed in and removed from a connecting rod.
- (2) With the pin removed from the piston and connecting rod, clean and dry piston pin bores and the replacement piston pin.
- (3) Position the piston so that the pin bore is in vertical position. Insert the pin in bore. At room temperature, the replacement pin should slide completely through the pin bore in piston by force of gravity.
- (4) Replace piston if pin jams in the pin bore.

INSTALLATION

- (1) Insert the piston pin pilot through the piston and connecting rod pin bores. Ensure that the arrow on the piston crown is pointing up (Fig. 10).
- (2) Position the pin pilot, piston and connecting rod on a support with the squirt hole of the connecting rod to the left-hand side (Fig. 10).
- (3) Insert piston pin through the upper piston pin bore and into the connecting rod pin bore.
- (4) Position the piloted driver inside the piston pin (Fig. 9).
- (5) Using an arbor press, press the piston pin through the connecting rod and piston bores until pin pilot indexes with mark on the support. The piston pin requires a 8 900 N (2,000 pounds) press-fit. If little effort is required to install piston pin in a connecting rod, or if the rod moves laterally on the pin, the connecting rod must be replaced.

(6) Remove the piston and connecting rod assembly from the press. The pin should be centered in the connecting rod (± 0.792 mm or ± 0.0312 inch) and float in the piston pin bore.

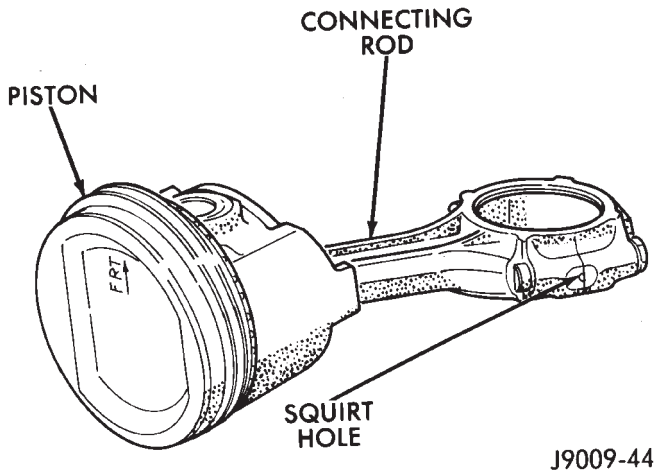

Fig. 10 Correct Alignment—Piston and Connecting Rod

PISTON RING FITTING

(1) Carefully clean the carbon from all ring grooves. Oil drain openings in the oil ring groove and pin boss must be clear. DO NOT remove metal from the grooves or lands. This will change ring-to-groove clearances and will damage the ring-to-land seating.

(2) Be sure the piston ring grooves are free of nicks and burrs.

(3) Measure the ring side clearance with a feeler gauge fitted snugly between the ring land and ring (Fig. 11). Rotate the ring in the groove. It must move freely around circumference of the groove.

(4) Place ring in the cylinder bore and push down with inverted piston to position near lower end of the ring travel. Measure ring gap with a feeler gauge fitting snugly between ring ends (Fig. 12). The correct compression ring end gap is 0.25-0.51 mm (0.010-0.020 inch). The correct oil control ring end gap is 0.381-1.397 mm (0.015-0.055 inch).

(5) Install the oil control rings according to instructions in the package. It is not necessary to use a tool to install the upper and lower rails. Insert oil rail spacer first, then side rails.

(6) The two compression rings are different and cannot be interchanged. The top ring (Fig. 13) is a moly ring (the scraping edge is gray in color). The second ring (Fig. 14) is a black cast iron ring (the scraping edge is black in color when new). The compression rings may also be identified by 1 or 2 dots on the top surface of the ring (Figs. 13 and 14).

(7) The second compression ring (black cast iron) has a chamfer on the BOTTOM of the inside edge (Fig. 15). This ring may also have 2 dots located on the top surface.

	Millimeters	Inches
No. 1 Compression	0.025-0.081 (0.043 Preferred)	0.001-0.0032 (0.0017 Preferred)
No. 2 Compression	0.025-0.081 (0.043 Preferred)	0.001-0.0032 (0.0017 Preferred)
Oil Control	0.025-0.241 (0.08 Preferred)	0.001-0.0095 (0.003 Preferred)

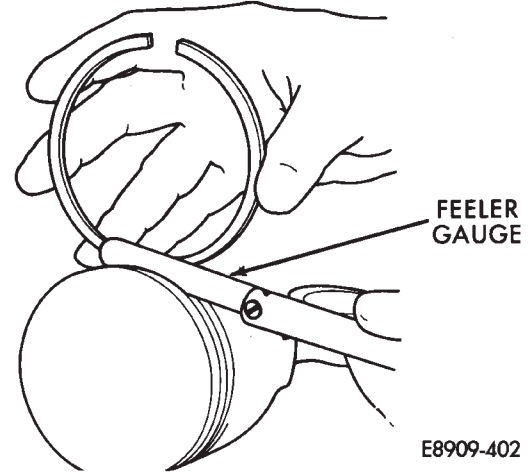

Fig. 11 Ring Side Clearance Measurement

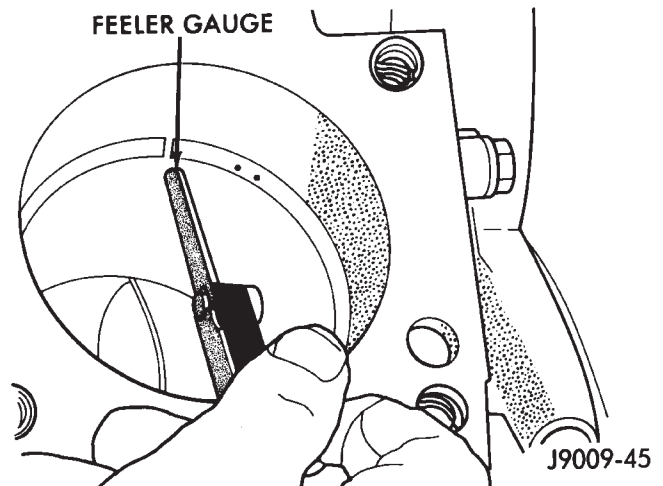

Fig. 12 Ring Gap Measurement

(8) Using a ring installer, install the second compression ring with the chamfer facing down (Fig. 16). The two dots will be facing up.

(9) The top compression ring (the scraping edge is gray in color) has a chamfer on the TOP of the inside edge (Fig. 15). This ring may also have 1 dot located on the top surface.

(10) Using a ring installer, install the top ring with the chamfer facing up (Fig. 16). The dot will be facing up.

(11) Position the gaps on the piston (Fig. 17):

- Oil spacer - Gap on center line of piston pin bore.
- Oil rails - Gap 180° apart on centerline of piston skirt.
- No. 2 Compression ring - Gap 180° from top oil rail gap.

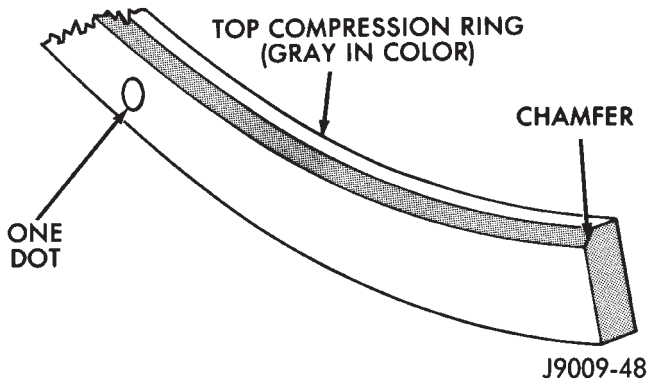

Fig. 13 Top Compression Ring Identification

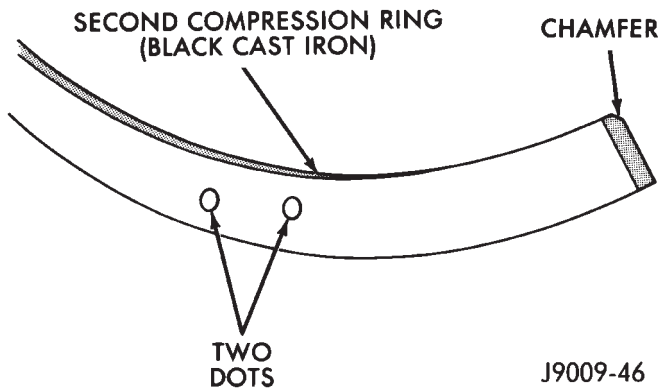

Fig. 14 Second Compression Ring Identification

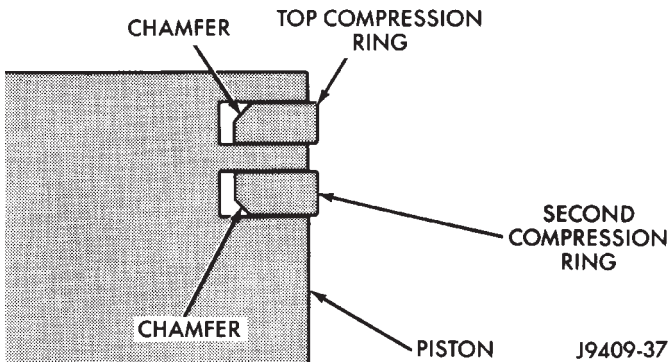

Fig. 15 Compression Ring Chamfer Location

- No. 1 Compression ring - Gap 180° from No. 2 compression ring gap.

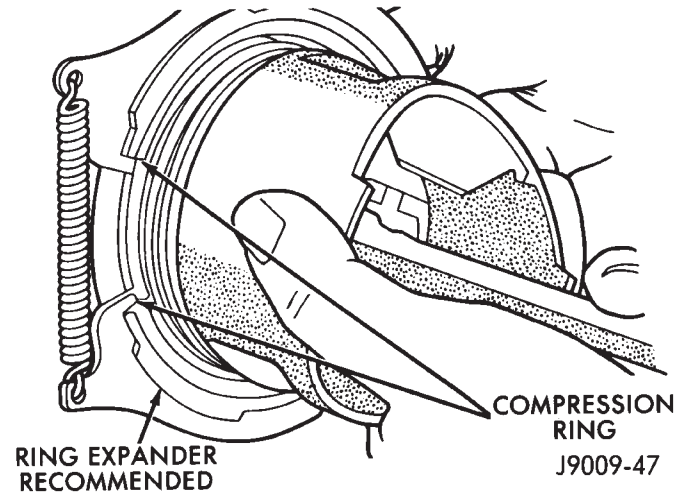

Fig. 16 Compression Ring Installation

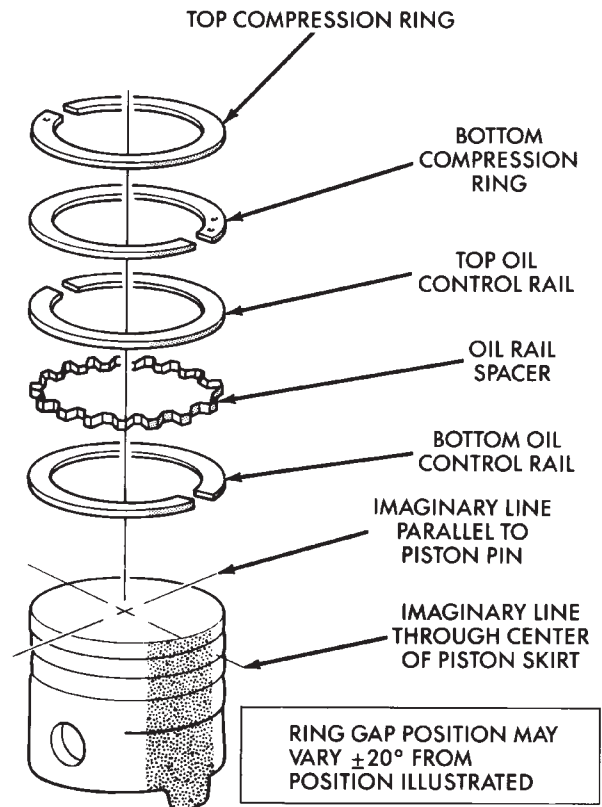

Fig. 17 Ring Gap Position

CLEANING

Clean the cylinder bores thoroughly. Apply a light film of clean engine oil to the bores with a clean lint-free cloth.

INSTALLATION

- (1) Install the piston rings on the pistons if removed.
- (2) Lubricate the piston and rings with clean engine oil.

CAUTION: Ensure that connecting rod bolts DO NOT scratch the crankshaft journals or cylinder walls. Short pieces of rubber hose slipped over the connecting rod bolts will provide protection during installation.

(3) Use a piston ring compressor to install the connecting rod and piston assemblies through the top of the cylinder bores (Fig. 18).

(4) Ensure the arrow on the piston top points to the front of the engine (Fig. 18).

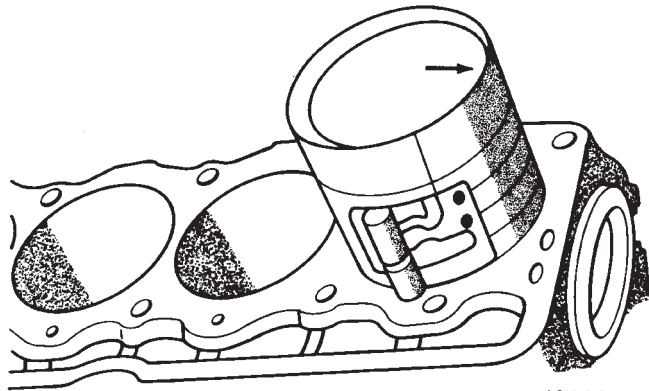

J9009-41

Fig. 18 Rod and Piston Assembly Installation

(5) Raise the vehicle.

Each bearing insert is fitted to its respective journal to obtain the specified clearance between the bearing and the journal. In production, the select fit is obtained by using various-sized, color-coded bearing inserts as listed in the Connecting Rod Bearing Fitting Chart. The color code appears on the edge of the bearing insert. The size is not stamped on inserts used for production of engines.

The rod journal is identified during the engine production by a color-coded paint mark on the adjacent cheek or counterweight toward the flange (rear) end of the crankshaft. The color codes used to indicate journal sizes are listed in the Connecting Rod Bearing Fitting Chart.

When required, upper and lower bearing inserts of different sizes may be used as a pair (refer to Connecting Rod Bearing Fitting Chart). A standard size insert is sometimes used in combination with a 0.025 mm (0.001 inch) undersize insert to reduce clearance 0.013 mm (0.0005 inch).

CAUTION: DO NOT intermix bearing caps. Each connecting rod and bearing cap are stamped with the cylinder number. The stamp is located on a machined surface adjacent to the oil squirt hole that faces the camshaft side of the cylinder block.

(6) Install the connecting rod bearing caps and inserts in the same positions as removed.

CAUTION: Verify that the oil squirt holes in the rods face the camshaft and that the arrows on the pistons face the front of the engine.

(7) Install the oil pan and gaskets as outlined in the installation procedure.

(8) Lower the vehicle.

(9) Install the engine cylinder head, push rods, rocker arms, bridges, pivots and engine cylinder head cover.

(10) Fill the crankcase with engine oil.

CRANKSHAFT MAIN BEARINGS

REMOVAL

- (1) Disconnect negative cable from battery.
- (2) Remove the spark plugs.
- (3) Raise the vehicle.
- (4) Remove the oil pan and oil pump.
- (5) Remove only one main bearing cap and lower insert at a time (Fig. 1).

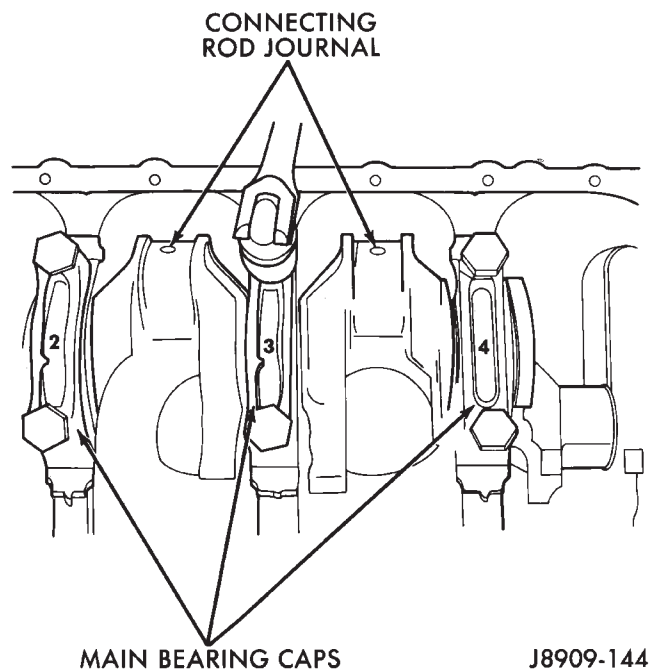

J8909-144

Fig. 1 Removing Main Bearing Caps and Lower Inserts

- (6) Remove the lower insert from the bearing cap.
- (7) Remove the upper insert by LOOSENING (DO NOT REMOVE) all of the other bearing caps. Now insert a small cotter pin tool in the crankshaft journal oil hole. Bend the cotter pin as illustrated to fabricate the tool (Fig. 2). With the cotter pin tool in place, rotate the crankshaft so that the upper bearing insert will rotate in the direction of its locking tab. Because there is no hole in the No.3 main journal, use a tongue depressor or similar soft-faced tool to remove the bearing insert (Fig. 2). After moving

the insert approximately 25 mm (1 inch), it can be removed by applying pressure under the tab.

(8) Using the same procedure described above, remove the remaining bearing inserts one at a time for inspection.

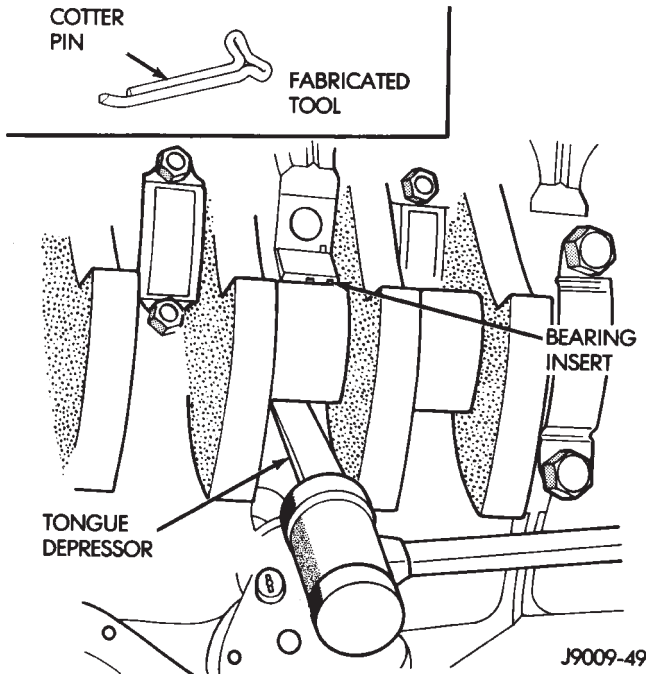

Fig. 2 Removing Upper Inserts

INSPECTION

Wipe the inserts clean and inspect for abnormal wear patterns and for metal or other foreign material imbedded in the lining. Normal main bearing insert wear patterns are illustrated (Fig. 3).

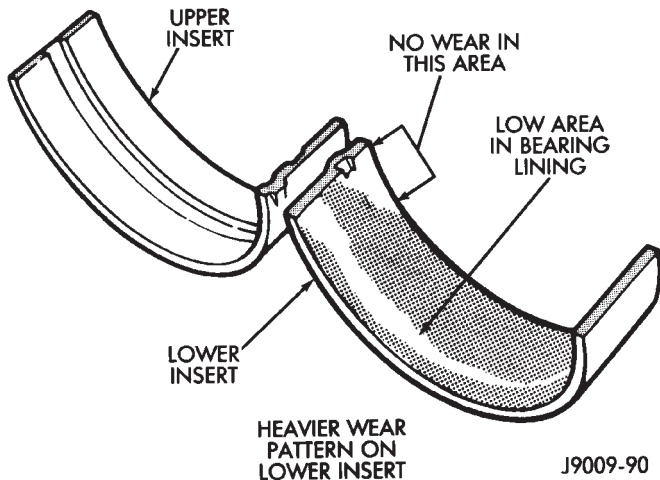

Fig. 3 Main Bearing Wear Patterns

If any of the crankshaft journals are scored, remove the engine for crankshaft repair.

Inspect the back of the inserts for fractures, scrapings or irregular wear patterns.

Inspect the upper insert locking tabs for damage.

Replace all damaged or worn bearing inserts.

FITTING (CRANKSHAFT INSTALLED)

The main bearing caps, numbered (front to rear) from 1 through 7 have an arrow to indicate the forward position. The upper main bearing inserts are grooved to provide oil channels while the lower inserts are smooth.

Each bearing insert pair is selectively fitted to its respective journal to obtain the specified operating clearance. In production, the select fit is obtained by using various-sized color-coded bearing insert pairs as listed in the Main Bearing Fitting Chart. The bearing color code appears on the edge of the insert. **The size is not stamped on bearing inserts used for engine production.**

The main bearing journal size (diameter) is identified by a color-coded paint mark on the adjacent cheek. The rear main journal, is identified by a color-coded paint mark on the crankshaft rear flange.

When required, upper and lower bearing inserts of different sizes may be used as a pair. A standard size insert is sometimes used in combination with a 0.025 mm (0.001 inch) undersize insert to reduce the clearance by 0.013 mm (0.0005 inch). **Never use a pair of bearing inserts with greater than a 0.025 mm (0.001 inch) difference in size (Fig. 4).**

Insert	Correct	Incorrect
Upper	Standard	Standard
Lower	0.025 mm (0.001 in.) Undersize	0.051 mm (0.002 in.) Undersize

J9109-179

Fig. 4 Bearing Insert Pairs

When replacing inserts, the odd size inserts must be either all on the top (in cylinder block) or all on the bottom (in main bearing cap).

Once the bearings have been properly fitted, proceed to Crankshaft Main Bearing—Installation.

BEARING-TO-JOURNAL CLEARANCE (CRANKSHAFT INSTALLED)

When using Plastigage, check only one bearing clearance at a time.

Install the grooved main bearings into the cylinder block and the non-grooved bearings into the bearing caps.

Install the crankshaft into the upper bearings dry.

Place a strip of Plastigage across full width of the crankshaft journal to be checked.

Install the bearing cap and tighten the bolts to 108 N·m (80 ft. lbs.) torque.

DO NOT rotate the crankshaft. This will cause the Plastigage to shift, resulting in an inaccurate reading. Plastigage must not be permitted to crumble. If brittle, obtain fresh stock.

Remove the bearing cap. Determine the amount of clearance by measuring the width of the compressed Plastigage with the scale on the Plastigage envelope (Fig. 5). Refer to Engine Specifications for the proper clearance.

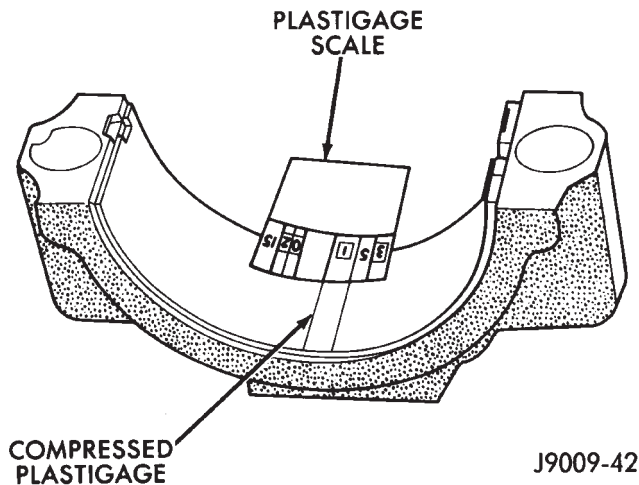

Fig. 5 Measuring Bearing Clearance with Plastigage

Plastigage should indicate the same clearance across the entire width of the insert. If clearance varies, it may indicate a tapered journal or foreign material trapped behind the insert.

If the specified clearance is indicated and there are no abnormal wear patterns, replacement of the bearing inserts is not necessary. Remove the Plastigage from the crankshaft journal and bearing insert. Proceed to Crankshaft Main Bearing—Installation.

If the clearance exceeds specification, install a pair of 0.025 mm (0.001 inch) undersize bearing inserts and measure the clearance as described in the previous steps.

The clearance indicated with the 0.025 mm (0.001 inch) undersize insert pair installed will determine if this insert size or some other combination will provide the specified clearance.

FOR EXAMPLE: If the clearance was 0.0762 mm (0.003 inch) originally, a pair of 0.0254 mm (0.001 inch) undersize inserts would reduce the clearance by 0.0254 mm (0.001 inch). The clearance would then be 0.0508 mm (0.002 inch) and within the specification. A 0.051 mm (0.002 inch) undersize bearing insert and a 0.0254 mm (0.001 inch) undersize insert would reduce the original clearance an additional 0.0127 mm (0.0005 inch). The clearance would then be 0.0381 mm (0.0015 inch).

CAUTION: Never use a pair of inserts that differ more than one bearing size as a pair.

FOR EXAMPLE: DO NOT use a standard size upper insert and a 0.051 mm (0.002 inch) undersize lower insert.

If the clearance exceeds specification using a pair of 0.051 mm (0.002 inch) undersize bearing inserts, measure crankshaft journal diameter with a micrometer. If the journal diameter is correct, the crankshaft bore in the cylinder block may be misaligned, which requires cylinder block replacement or machining to true bore.

Replace the crankshaft or grind to accept the appropriate undersize bearing inserts if:

- Journal diameters 1 through 6 are less than 63.4517 mm (2.4981 inches)
- Journal 7 diameter is less than 63.4365 mm (2.4975 inches).

Once the proper clearances have been obtained, proceed to Crankshaft Main Bearing—Installation.

MAIN BEARING JOURNAL DIAMETER (CRANKSHAFT REMOVED)

Remove the crankshaft from the cylinder block (refer to Cylinder Block - Disassemble).

Clean the oil off the main bearing journal.

Determine the maximum diameter of the journal with a micrometer. Measure at two locations 90° apart at each end of the journal.

The maximum allowable taper and out of round is 0.013 mm (0.0005 inch). Compare the measured diameter with the journal diameter specification (Main Bearing Fitting Chart). Select inserts required to obtain the specified bearing-to-journal clearance.

Install the crankshaft into the cylinder block (refer to Cylinder Block - Assemble and Crankshaft Main Bearings - Installation).

INSTALLATION

(1) Lubricate the bearing surface of each insert with engine oil.

(2) Loosen all the main bearing caps. Install the main bearing upper inserts.

(3) Install the lower bearing inserts into the main bearing caps.

(4) Install the main bearing cap(s) and lower insert(s).

(5) Tighten the bolts of caps 1, 2, 4, 5, 6, and 7 to 54 N·m (40 ft. lbs.) torque. Now tighten these bolts to 95 N·m (70 ft. lbs.) torque. Finally, tighten these bolts to 108 N·m (80 ft. lbs.) torque.

(6) Push the crankshaft forward and backward. Load the crankshaft front or rear and tighten cap bolt No.3 to 54 N·m (40 ft. lbs.) torque. Then tighten to 95 N·m (70 ft. lbs.) torque and finally tighten to 108 N·m (80 ft. lbs.) torque.

(7) Rotate the crankshaft after tightening each main bearing cap to ensure the crankshaft rotates freely.

MAIN BEARING FITTING CHART

Crankshaft Journals #1 - #6		Corresponding Crankshaft Bearing Insert	
Color Code	Diameter	Upper Insert Size	Lower Insert Size
Yellow	63.5025-63.4898 mm (2.5001-2.4996 in.)	Yellow - Standard	Yellow - Standard
Orange	63.4898-63.4771 mm (2.4996-2.4991 in.) 0.0127 mm (0.0005 in.) Undersize	Blue - Undersize 0.025 mm (0.001 in.)	Yellow - Standard
Blue	63.4771-63.4644 mm (2.4991-2.4986 in.) 0.0254 mm (0.001 in.) Undersize	Blue - Undersize 0.025 mm (0.001 in.)	Blue - Undersize 0.025 mm (0.001 in.)
Green	63.4644-63.4517 mm (2.4986-2.4981 in.) 0.0381 mm (0.0015 in.) Undersize	Blue - Undersize 0.025 mm (0.001 in.)	Green - Undersize 0.051 mm (0.002 in.)
Red	63.2485-63.2358 mm (2.4901-2.4896 in.) 0.254 mm (0.010 in.) Undersize	Red - Undersize 0.254 mm (0.010 in.)	Red - Undersize 0.254 mm (0.010 in.)

Crankshaft Journals #7 Only		Corresponding Crankshaft Bearing Insert	
Color Code	Diameter	Upper Insert Size	Lower Insert Size
Yellow	63.4873-63.4746 mm (2.4995-2.4990 in.)	Yellow - Standard	Yellow - Standard
Orange	63.4746-63.4619 mm (2.4990-2.4985 in.) 0.0127 mm (0.0005 in.) Undersize	Blue - Undersize 0.025 mm (0.001 in.)	Yellow - Standard
Blue	63.4619-63.4492 mm (2.4985-2.4980 in.) 0.0254 mm (0.001 in.) Undersize	Blue - Undersize 0.025 mm (0.001 in.)	Blue - Undersize 0.025 mm (0.001 in.)
Green	63.4492-63.4365 mm (2.4980-2.4975 in.) 0.0381 mm (0.0015 in.) Undersize	Blue - Undersize 0.025 mm (0.001 in.)	Green - Undersize 0.051 mm (0.002 in.)
Red	63.2333-63.2206 mm (2.4895-2.4890 in.) 0.254 mm (0.010 in.) Undersize	Red - Undersize 0.254 mm (0.010 in.)	Red - Undersize 0.254 mm (0.010 in.)

(8) Check crankshaft end play. Crankshaft end play is controlled by the thrust bearing which is flange and installed at the No.2 main bearing position.

(a) Attach a magnetic base dial indicator to the cylinder block at either the front or rear of the engine.

(b) Position the dial indicator rod so that it is parallel to the center line of the crankshaft.

(c) Pry the crankshaft forward, position the dial indicator to zero.

(d) Pry the crankshaft forward and backward. Note the dial indicator readings. End play is the difference between the high and low measurements (Fig. 6). Correct end play is 0.038-0.165 mm (0.0015-0.0065 inch). The desired specifications are 0.051-0.064 mm (0.002-0.0025 inch).

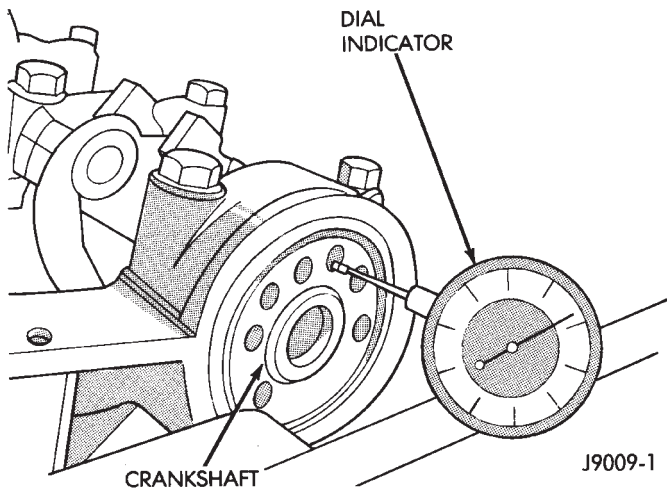

Fig. 6 Crankshaft End Play Measurement

(e) If end play is not within specification, inspect crankshaft thrust faces for wear. If no wear is apparent, replace the thrust bearing and measure end play. If end play is still not within specification, replace the crankshaft.

If the crankshaft was removed, install the crankshaft into the cylinder block (refer to Cylinder Block - Assemble).

(9) Install the oil pan.

(10) Install the drain plug. Tighten the plug to 34 N·m (25 ft. lbs.) torque.

(11) Lower the vehicle.

(12) Install the spark plugs. Tighten the plugs to 37 N·m (27 ft. lbs.) torque.

(13) Fill the oil pan with engine oil to the full mark on the dipstick level.

(14) Connect negative cable to battery.

REAR MAIN OIL SEALS

The crankshaft rear main bearing oil seal consists of two half pieces of viton with a single lip that ef-

fectively seals the rear of the crankshaft. Replace the upper and lower seal halves as a unit to ensure leak-free operation.

REMOVAL

(1) Remove the engine flywheel or converter drive plate.

(2) Remove the oil pan.

(3) Remove the rear main bearing cap (No.7).

(4) Push the upper seal out of the groove. Ensure that the crankshaft and seal groove are not damaged.

(5) Remove the lower half of the seal from the bearing cap.

INSTALLATION

(1) Wipe the seal surface area of the crankshaft until it is clean.

(2) Apply a thin coat of engine oil.

(3) Coat the lip of the seal with engine oil.

(4) Carefully position the upper seal into the groove in the cylinder block. The lip of the seal faces toward the front of the engine.

(5) Place the lower half of the seal into bearing cap No.7 (Fig. 7).

(6) Coat the outer curved surface of the lower seal with soap and the lip of the seal with engine oil (Fig. 7).

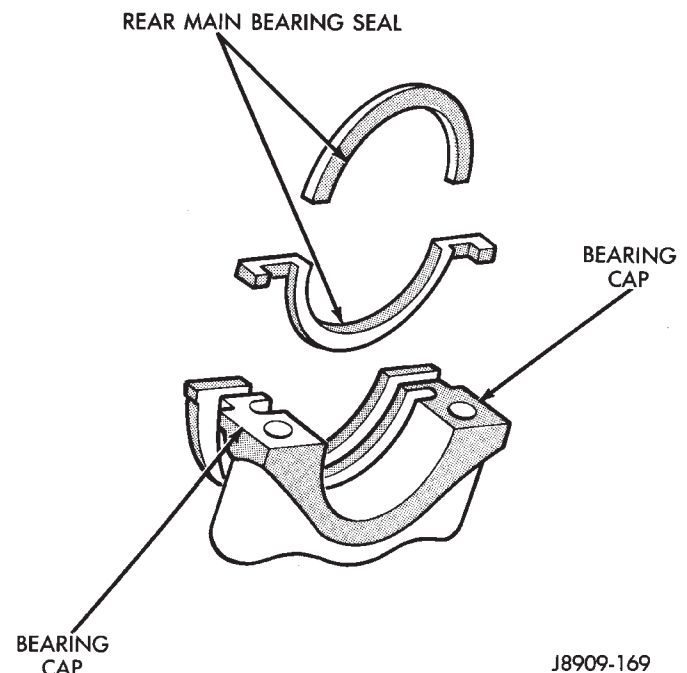

Fig. 7 Rear Main Bearing Oil Seal

(7) Position the lower seal into the bearing cap recess and seat it firmly. Be sure the seal is flush with the cylinder block pan rail.

(8) Apply Loctite 515, or equivalent on the rear bearing cap (Fig. 8). The bead should be 3 mm (0.125 in) thick. DO NOT apply Loctite 515, or equivalent to the lip of the seal.

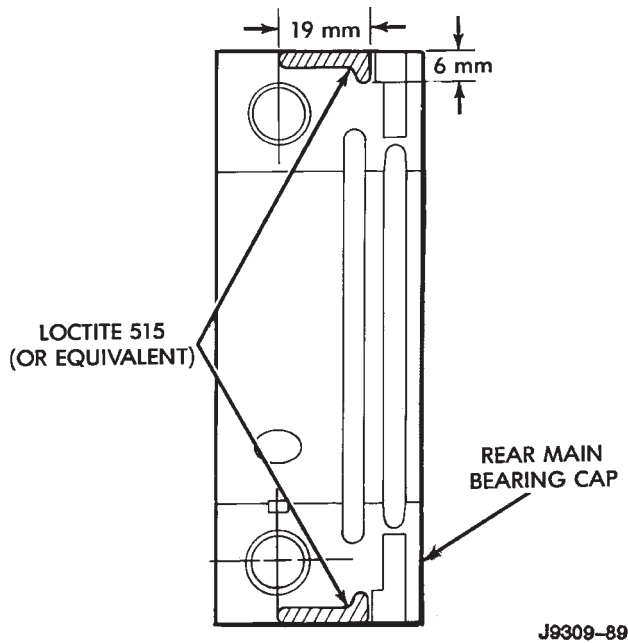

Fig. 8 Location of Loctite 515 (or equivalent)

(9) Install the rear main bearing cap. DO NOT strike the cap more than twice for proper engagement.

(10) Tighten all main bearing bolts to 108 N·m (80 ft. lbs.) torque.

(11) Install the oil pan gasket and oil pan.

(12) Install the engine flywheel or converter drive plate.

CYLINDER BLOCK

Remove the Engine Assembly from the vehicle.

DISASSEMBLY

Refer to the applicable sections for detailed instructions.

(1) Drain the engine oil. Remove and discard the oil filter.

(2) Remove the water pump from the cylinder block.

(3) Remove the vibration damper.

(4) Remove the timing case cover and lay the cover upside down.

(5) Position a drift punch into the slot in the back of the cover and tap the old seal out.

(6) Remove the oil slinger from crankshaft.

(7) Remove the camshaft retaining bolt and remove the sprockets and chain as an assembly.

(8) Remove the camshaft.

(9) Remove the oil pan and gasket.

(10) Remove the front and rear oil galley plugs.

(11) Remove the oil pump.

(12) Remove the connecting rods and the pistons. Remove the connecting rod and piston assemblies through the top of the cylinder bores.

(13) Remove the crankshaft.

CLEANING

Thoroughly clean the oil pan and engine block gasket surfaces.

Use compressed air to clean out:

- The galley at the oil filter adaptor hole, the filter bypass hole.
- The front and rear oil galley holes.
- The feed holes for the crankshaft main bearings.

Once the block has been completely cleaned, apply Loctite PST pipe sealant with Teflon 592 to the threads of the front and rear oil galley plugs. Tighten the plugs to 41 N·m (30 ft. lbs.) torque.

INSPECTION—CYLINDER BORE

(1) Use a bore gauge to measure each cylinder bore diameter (Fig. 9). If a bore gauge is not available, use an inside micrometer.

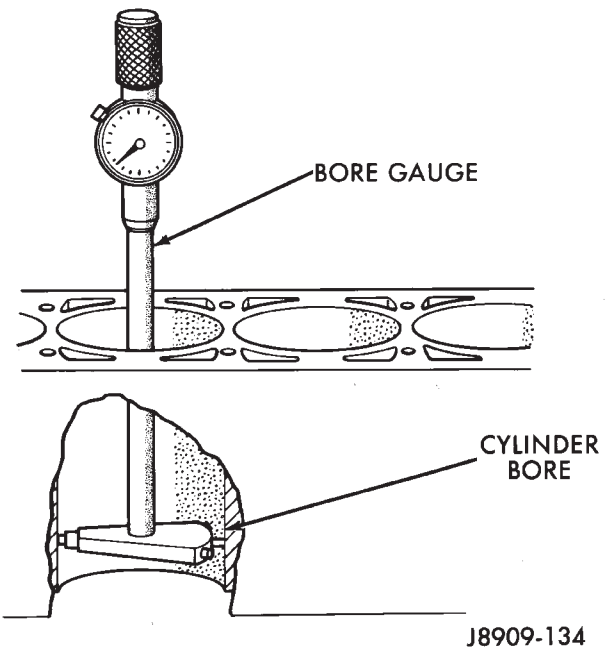

Fig. 9 Cylinder Bore Measurement

(2) Measure the cylinder bore diameter crosswise to the cylinder block near the top of the bore. Repeat the measurement near the bottom of the bore.

(3) Determine taper by subtracting the smaller diameter from the larger diameter.

(4) Rotate measuring device 120° and repeat steps above. Finally, rotate the device another 120° and repeat measurements.

(5) Determine out-of-roundness by comparing the difference between each 120° measurement.

(6) If cylinder bore taper does not exceed 0.025 mm (0.001 inch) and out-of-roundness does not exceed 0.025 mm (0.001 inch), the cylinder bore can be honed. If the cylinder bore taper or out-of-round condition exceeds these maximum limits, the cylinder must be bored and then honed to accept an oversize

piston. A slight amount of taper always exists in the cylinder bore after the engine has been in use for a period of time.

HONING—CYLINDER BORE

The honing operation should be closely coordinated with the fitting of pistons and rings. This will ensure specified clearances are maintained.

Refer to Standard Service Procedures in the beginning of this Group for the proper honing of cylinder bores.

ASSEMBLY

Refer to the applicable sections for detailed instructions.

- (1) Install the crankshaft.
- (2) Install the connecting rods and the pistons through the top of the cylinder bores.
- (3) Install the oil pump.
- (4) Install the oil pan and gasket.
- (5) Install the camshaft.
- (6) Install the sprockets and chain as an assembly.
- (7) Install the oil slinger from the crankshaft.
- (8) Install the timing case cover seal.
- (9) Install the timing case cover.
- (10) Install the vibration damper.
- (11) Install the water pump. Tighten the mounting bolts to 31 N·m (270 in. lbs.) torque.
- (12) Lubricate the oil filter seal with clean engine oil. Tighten oil filter to 18 N·m (13 ft. lbs.) torque.
- (13) Install the engine into the vehicle.
- (14) Fill the engine with clean lubrication oil (refer to Group 0, Lubrication and Maintenance).
- (15) Fill the cooling system (refer to Group 7, Cooling System for the proper procedures).

SPECIFICATIONS

ENGINE SPECIFICATIONS

Camshaft

Hydraulic Tappet Clearance	Zero Lash
Bearing Clearance.....	0.025 - 0.076 mm (0.001 - 0.003 in)
Bearing Journal Diameter	
No.1.....	51.54 - 51.56 mm (2.029 - 2.030 in)
No.2.....	51.28 - 51.31 mm (2.019 - 2.020 in)
No.3.....	51.03 - 51.05 mm (2.009 - 2.010 in)
No.4.....	50.78 - 50.80 mm (1.999 - 2.000 in)
Base Circle Runout.....	0.03 mm - max. (0.001 in - max.)
Camshaft Lobe Lift	6.43 mm (0.253 in)
Valve Lift.....	10.29 mm (0.405 in)
Intake Valve Timing	
Opens.....	15°BTDC
Closes.....	75°ABDC
Exhaust Valve Timing	
Opens.....	59°BBDC
Closes.....	31°ATDC
Valve Overlap.....	46°
Intake Duration.....	270°
Exhaust Duration.....	270°

Crankshaft

End Play.....	0.038 - 0.165 mm (0.0015 - 0.0065 in)
Main Bearing Journal Diameter	
No.1-6.....	63.489 - 63.502 mm (2.4996 - 2.5001 in)
No.7.....	63.449 - 63.487 mm (2.4980 - 2.4995 in)
Main Bearing Journal Width	
No.1.....	27.58 - 27.89 mm (1.086 - 1.098 in)
No.3.....	32.28 - 32.33 mm (1.271 - 1.273 in)
No.2-4-5-6-7.....	30.02 - 30.18 mm (1.182 - 1.188 in)
Main Bearing Clearance	0.03 - 0.06 mm (0.001 - 0.0025 in)
Preferred	0.051 mm (0.002 in)
Connecting Rod Journal Dia.....	53.17 - 53.23 mm (2.0934 - 2.0955 in)
Connecting Rod Journal Width.....	27.18 - 27.33 mm (1.070 - 1.076 in)
Out-of-Round (Max. All Journals)	0.013 mm (0.0005 in)
Taper (Max. - All Journals).....	0.013 mm (0.0005 in)

Cylinder Block

Deck Height.....	240.03 - 240.18 mm (9.450 - 9.456 in)
Deck Clearance (Below Block)	0.546 mm (0.0215 in)
Cylinder Bore Diameter	
Standard	98.45 - 98.48 mm (3.8759 - 3.8775 in)
Taper (Max.)	0.025 mm (0.001 in)
Out-of-Round.....	0.025 mm (0.001 in)
Tappet Bore Diameter.....	23.000 - 23.025 mm (0.9055 - 0.9065 in)
Flatness	0.03 mm per 25 mm (0.001 in per 1 in)
	0.05 mm per 152 mm (0.002 in per 6 in)
	0.20 mm - max. for total length (0.008 in - max. for total length)
Main Bearing Bore Dia.	68.3514 - 68.3768 mm (2.691 - 2.692 in)

Connecting Rods

Total Weight (Less Bearing).....	657 - 665 grams (23.17 - 23.45 oz)
Length (Center-to-Center).....	155.52 - 155.62 mm (6.123 - 6.127 in)
Piston Pin Bore Diameter.....	23.59 - 23.62 mm (0.9288 - 0.9298 in)
Bore (Less Bearings)	56.08 - 56.09 mm (2.2080 - 2.2085 in)
Bearing Clearance.....	0.025 - 0.076 mm (0.001 - 0.003 in)
Preferred.....	0.044 - 0.050 mm (0.0015 - 0.0020 in)
Side Clearance.....	0.25 - 0.48 mm (0.010 - 0.019 in)
Twist (Max.).....	0.001 mm per mm (0.001 in per in)
Bend (Max.).....	0.0005 mm per mm (0.0005 in per in)

Cylinder Compression Pressure

Ratio.....	8.7:1
Pressure Range.....	827 - 1 034 kPa (120 - 150 psi)
Max. Variation Between Cylinders	206 kPa (30 psi)

ENGINE SPECIFICATIONS (CONT.)

Cylinder Head

Combustion Chamber	55.22 - 58.22 cc (3.37 - 3.55 cu. in.)
Valve Guide I.D. (Integral)	7.9 mm (0.312 in)
Valve Stem-to-Guide Clearance	0.025 - 0.076 mm (0.001 - 0.003 in)
Intake Valve Seat Angle	44.5°
Exhaust Valve Seat Angle	44.5°
Valve Seat Width	1.02 - 1.52 mm (0.040 - 0.060 in)
Valve Seat Runout	0.064 mm (0.0025 in)
Flatness	0.03 mm per 25 mm (0.001 in per 1 in) 0.05 mm per 152 mm (0.002 in per 6 in) 0.20 mm - max. for total length (0.008 in - max. for total length)

Rocker Arms, Push Rods & Tappets

Rocker Arm Ratio	1.6:1
Push Rod Length	244.856 - 245.364 mm (9.640 - 9.660 in)
Push Rod Diameter	7.92 - 8.00 mm (0.312 - 0.315 in)
Hydraulic Tappet Diameter	22.962 - 22.974 mm (0.904 - 0.9045 in)
Tappet-to-Bore Clearance	0.025 - 0.063 mm (0.001 - 0.0025 in)

Valves

Length (Tip-to-Gauge Dimension Line)	
Intake	122.479 - 122.860 mm (4.822 - 4.837 in)
Exhaust	122.860 - 123.241 mm (4.837 - 4.852 in)
Valve Stem Diameter	7.899 - 7.925 mm (0.311 - 0.312 in)
Stem-to-Guide Clearance	0.025 - 0.076 mm (0.001 - 0.003 in)
Valve Head Diameter	
Intake	48.387 - 48.641 mm (1.905 - 1.915 in)
Exhaust	37.973 - 38.227 mm (1.495 - 1.505 in)
Valve Face Angle	
Intake	45°
Exhaust	45°
Tip Refinishing (Max. Allowable)	0.25 mm (0.010 in)

Valve Springs

Free Length (Approx.)	49.962 mm (1.967 in)
Spring Tension	
Valve Closed	360 - 396 N @ 41.656 mm (81 - 89 lbf @ 1.640 in)
Valve Open	845 - 934 N @ 30.886 mm (190 - 210 lbf @ 1.216 in)
Inside Diameter	24.08 - 24.59 mm (0.948 - 0.968 in)

Pistons

Weight (Less Pin)	563 - 567 grams (19.86 - 20.00 oz)
Piston Pin Bore (Centerline-to-Piston Top)	40.61 - 40.72 mm 1.599 - 1.603 in
Piston-to-Bore Clearance	0.033 - 0.053 mm (0.0013 - 0.0021 in)
Preferred	0.033 - 0.038 mm (0.0013 - 0.0015 in)
Piston Ring Gap Clearance	
Compression Rings	0.25 - 0.51 mm (0.010 - 0.020 in)
Oil Control Steel Rails	0.25 - 0.64 mm (0.010 - 0.025 in)
Piston Ring Side Clearance	
Compression Rings	0.025 - 0.081 mm (0.001 - 0.0032 in)
Preferred	0.025 mm (0.001 in)
Oil Control Ring	0.025 - 0.241 mm (0.001 - 0.0095 in)
Preferred	0.08 mm (0.003 in)
Piston Ring Groove Height	
Compression Rings	2.019 - 2.045 mm (0.0795 - 0.0805 in)
Oil Control Ring	4.78 - 4.80 mm (0.1880 - 0.1895 in)
Piston Ring Groove Diameter	
Compression Rings	88.30 - 88.55 mm (3.476 - 3.486 in)
Oil Control Ring	90.35 - 90.60 mm (3.557 - 3.566 in)
Piston Pin Bore Diameter	23.647 - 23.655 mm (0.9310 - 0.9313 in)
Piston Pin Diameter	23.637 - 23.640 mm (0.9306 - 0.9307 in)
Piston-to-Pin Clearance	0.0076 - 0.0178 mm - Loose (0.0003 - 0.0007 in - Loose)
Preferred	0.013 mm (0.0005 in)
Piston-to-Pin Connecting Rod (Press Fit)	8.9 kN (2000 lb-f)

ENGINE SPECIFICATIONS (CONT.)

Oil Pump

Gear-to-Body Clearance (Radial)	0.051 - 0.102 mm (0.002 - 0.004 in)
Preferred	0.051 mm (0.002 in)
Gear End Clearance	
Plastigage	0.051 - 0.152 mm (0.002 - 0.006 in)
Preferred	0.051 mm (0.002 in)
Feeler Gauge	0.1016 - 0.2032 mm (0.004 - 0.008 in)
Preferred	0.1778 mm (0.007 in)

Oil Pressure

At Idle Speed (600 rpm)	89.6 kPa (13 psi)
At 1600 rpm & higher	255 - 517 kPa (37 - 75 psi)
Oil Pressure Relief	517 kPa (75 psi)

J9409-33

TORQUE SPECIFICATIONS

Description	Torque
A/C Compressor Bracket-to-Engine Bolts	34 N•m (25 ft. lbs.)
A/C Compressor Mounting Bolts	27 N•m (20 ft. lbs.)
A/C Low Pressure Service Valve Nut	38 N•m (28 ft. lbs.)
Block Heater Nut	1.8 N•m (16 in. lbs.)
Camshaft Sprocket Bolt	108 N•m (80 ft. lbs.)
Connecting Rod Nuts	45 N•m (33 ft. lbs.)
Cylinder Block Drain Plugs	41 N•m (30 ft. lbs.)
Cylinder Head Bolts	
(#1-10 & #12-14)	149 N•m (110 ft. lbs.)
(#11)	135 N•m (100 ft. lbs.)
Cylinder Head Cover Bolts	10 N•m (85 in. lbs.)
Engine Mounts—Front	
Engine Support Bracket	
Bolts (XJ)	61 N•m (45 ft. lbs.)
Bolts (YJ)	62 N•m (46 ft. lbs.)
Support Cushion	
Bolts/Nuts (XJ)	41 N•m (30 ft. lbs.)
Bolts/Nuts (YJ)	52 N•m (38 ft. lbs.)
Support Cushion Bracket—(XJ)	
Bolts	54 N•m (40 ft. lbs.)
Stud Nuts	41 N•m (30 ft. lbs.)
Support Cushion Thru-Bolt	
XJ Vehicles	65 N•m (48 ft. lbs.)
YJ Vehicles	69 N•m (51 ft. lbs.)
Engine Mount—Rear	
Crossmember-to-Sill Bolts	
(XJ-Automatic)	41 N•m (30 ft. lbs.)
Insulator Stud Assembly Nut	41 N•m (30 ft. lbs.)
Skid Plate/Support Cushion	
Stud Nuts (YJ)	54 N•m (40 ft. lbs.)
Skid Plate-to-Sill Bolts (YJ)	88 N•m (65 ft. lbs.)
Support Cushion/Crossmember	
Nuts (XJ)	22 N•m (192 in. lbs.)
Support Cushion/Support Bracket	
Nuts (XJ Manual)	75 N•m (55 ft. lbs.)
Support Cushion/Torque Arm	
Bracket Nuts (YJ)	54 N•m (40 ft. lbs.)
Torque Arm Bracket Bolts	
(YJ-Automatic)	54 N•m (40 ft. lbs.)

Description	Torque
Engine Mount—Rear (Cont.)	
Torque Arm Bracket/Support Cushion	
Bolts (YJ-Manual)	54 N•m (40 ft. lbs.)
Transmission Support Adaptor Bracket	
Bolts (XJ 2WD Auto)	75 N•m (55 ft. lbs.)
Transmission Support Bracket	
Bolts (XJ-Manual)	46 N•m (34 ft. lbs.)
Transmission Support Bracket/Support	
Cushion Bolts (XJ Automatic)	75 N•m (55 ft. lbs.)
Exhaust Manifold/Pipe Nuts	27 N•m (20 ft. lbs.)
Flywheel/Converter Housing Bolts	38 N•m (28 ft. lbs.)
Flywheel/Crankshaft Bolts	143 N•m (105 ft. lbs.)
Front Cover-to-Block Bolts (1/4-20)	7 N•m (60 in. lbs.)
Front Cover-to-Block Bolts (5/16-18)	22 N•m (192 in. lbs.)
Fuel Pump Bolts	22 N•m (16 ft. lbs.)
Generator Adjusting Bolt	24 N•m (18 ft. lbs.)
Generator Pivot Bolt/Nut	38 N•m (28 ft. lbs.)
Main Bearing Bolts	108 N•m (80 ft. lbs.)
Oil Filter	18 N•m (13 ft. lbs.)
Oil Filter Adaptor Bolts	102 N•m (75 ft. lbs.)
Oil Galley Plug	41 N•m (30 ft. lbs.)
Oil Pan Bolts (1/4-20)	14 N•m (120 in. lbs.)
(5/16-18)	18 N•m (156 in. lbs.)
Oil Pan Drain Plug	34 N•m (25 ft. lbs.)
Oil Pump Attaching Bolts	
Short Bolts	14 N•m (10 ft. lbs.)
Long Bolts	23 N•m (17 ft. lbs.)
Oil Pump Cover Bolts	8 N•m (70 in. lbs.)
Power Steering Pump Pressure	
Hose Nut	52 N•m (38 ft. lbs.)
Rocker Arm Assembly-to-Cylinder	
Head Capscrews	28 N•m (21 ft. lbs.)
Spark Plugs	37 N•m (27 ft. lbs.)
Starting Motor Mounting Bolts	45 N•m (33 ft. lbs.)
Thermostat Housing	18 N•m (156 in. lbs.)
Vibration Damper Bolts	108 N•m (80 ft. lbs.)
Water Pump/Block Bolts	31 N•m (270 in. lbs.)

J9409-50

