

EXHAUST SYSTEM AND TURBOCHARGER

CONTENTS

	page		page
GENERAL INFORMATION		EXHAUST PIPE	2
EXHAUST HEAT SHIELDS	1	INTAKE MANIFOLD	10
EXHAUST SYSTEM	1	MUFFLER AND EXHAUST TAILPIPE	2
REMOVAL AND INSTALLATION		SPECIFICATIONS	
EXHAUST MANIFOLD AND TURBOCHARGER		TORQUE SPECIFICATIONS	10
(LHD)	3		
EXHAUST MANIFOLD AND TURBOCHARGER			
(RHD)	5		

GENERAL INFORMATION

EXHAUST SYSTEM

The basic exhaust system consists of an engine exhaust manifold, exhaust pipe, exhaust heat shield(s), muffler and exhaust tailpipe.

The exhaust system uses a single muffler.

The exhaust system must be properly aligned to prevent stress, leakage and body contact. If the system contacts any body panel, it may amplify objectionable noises originating from the engine or body.

When inspecting an exhaust system, critically inspect for cracked or loose joints, stripped screw or bolt threads, corrosion damage and worn, cracked or broken hangers. Replace all components that are badly corroded or damaged. DO NOT attempt to repair.

When replacement is required, use original equipment parts (or equivalent). This will assure proper alignment and provide acceptable exhaust noise levels.

CAUTION: Avoid application of rust prevention compounds or undercoating materials to exhaust system floor pan exhaust heat shields. Light overspray near the edges is permitted. Application of coating will result in excessive floor pan temperatures and objectionable fumes.

EXHAUST HEAT SHIELDS

Exhaust heat shields are needed to protect both the vehicle and the environment from the high temperatures (Fig. 1).

DO NOT allow the engine to operate at fast idle for extended periods (over 5 minutes). This condition may result in excessive temperatures in the exhaust system and on the floor pan.

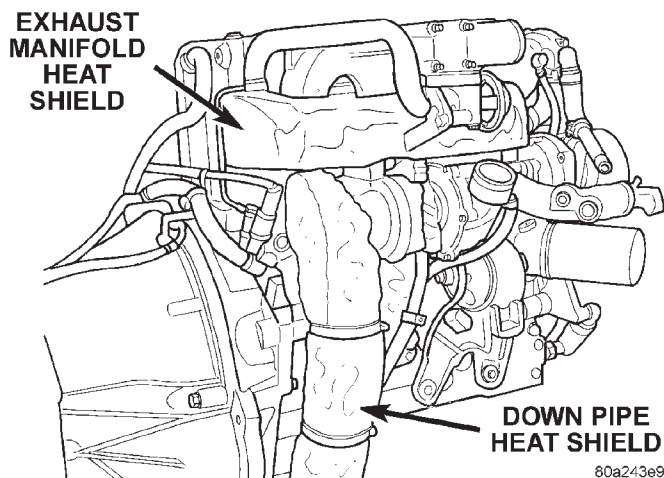

Fig. 1 Heat Shields

80a243e9

REMOVAL AND INSTALLATION

EXHAUST PIPE

WARNING: IF TORCHES ARE USED WHEN WORKING ON THE EXHAUST SYSTEM, DO NOT ALLOW THE FLAME NEAR THE FUEL LINES.

REMOVAL

- (1) Raise and support the vehicle.
- (2) Saturate the bolts and nuts at turbo down pipe to exhaust pipe with heat valve lubricant. Allow 5 minutes for penetration.
- (3) Disconnect bolts from exhaust pipe to turbo down pipe (Fig. 2).

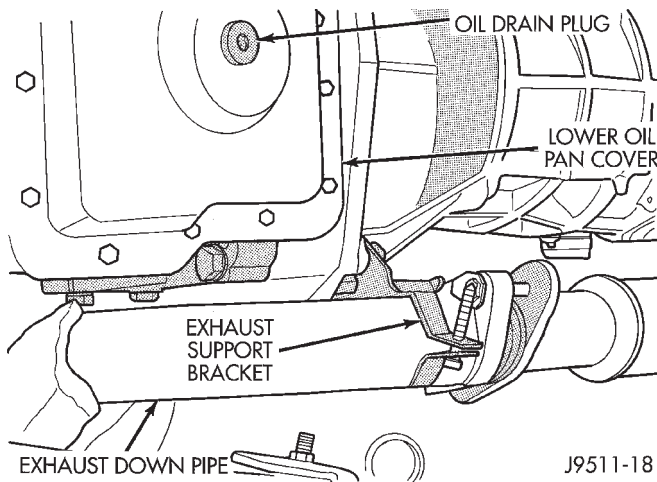

Fig. 2 Exhaust Down Pipe to Front Exhaust Pipe

- (4) Remove the clamp nuts at muffler (Fig. 3). To remove the exhaust pipe from the muffler, apply heat until the metal becomes cherry red. Disconnect the exhaust pipe from the muffler. Remove the exhaust pipe.

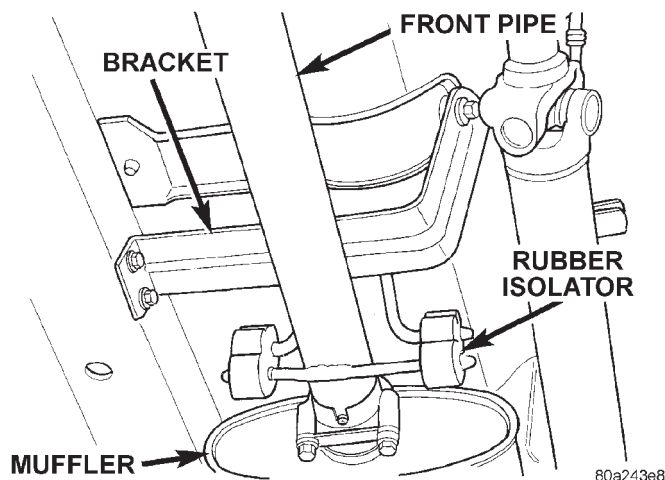

Fig. 3 Front Pipe to Muffler

INSTALLATION

- (1) Assemble exhaust pipe to muffler, loosely to permit proper alignment of all parts.
- (2) Connect the exhaust pipe to the turbo down pipe manifold. Tighten the bolts to 22.5 N·m torque.
- (3) Use a new clamp and tighten the nuts to 43 N·m torque.
- (4) Lower the vehicle.
- (5) Start the engine and inspect for exhaust leaks and exhaust system contact with the body panels. Adjust the alignment, if needed.

MUFFLER AND EXHAUST TAILPIPE

All original equipment exhaust systems are manufactured with the exhaust tailpipe welded to the muffler. Service replacement mufflers and exhaust tailpipes are either clamped together or welded together.

WARNING: IF TORCHES ARE USED WHEN WORKING ON THE EXHAUST SYSTEM, DO NOT ALLOW THE FLAME NEAR THE FUEL LINES.

REMOVAL

- (1) Raise and support the vehicle.
- (2) Remove the front muffler clamp from the exhaust pipe and muffler connection.
- (3) Remove the rear exhaust tailpipe hanger clamp and remove the exhaust tailpipe from the front exhaust tailpipe hanger.
- (4) Remove the exhaust tailpipe assembly from the muffler.

INSTALLATION

- (1) Install the muffler onto the exhaust pipe. Install the clamp and tighten the nuts finger tight.
- (2) Install the exhaust tailpipe into the rear of the muffler.
- (3) Install the exhaust tailpipe/muffler assembly on the rear exhaust tailpipe hanger. Make sure that the exhaust tailpipe has sufficient clearance from the floor pan.
- (4) Install the remaining clamps and the front exhaust tailpipe hanger.
- (5) Tighten the nuts on the muffler-to-exhaust pipe clamp to 43 N·m torque.
- (6) Tighten the nuts on the muffler-to-exhaust pipe clamp to 43 N·m torque.
- (7) Lower the vehicle.
- (8) Start the engine and inspect for exhaust leaks and exhaust system contact with the body panels. Adjust the alignment, if needed.

REMOVAL AND INSTALLATION (Continued)

EXHAUST MANIFOLD AND TURBOCHARGER (LHD)

REMOVAL

- (1) Disconnect the negative battery cable.
- (2) Disconnect the breather hose from air cleaner outlet hose (Fig. 4).

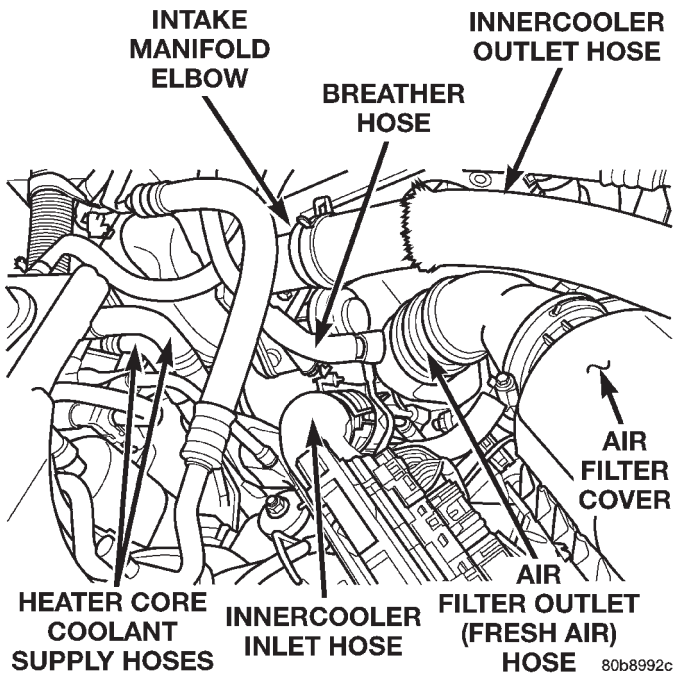
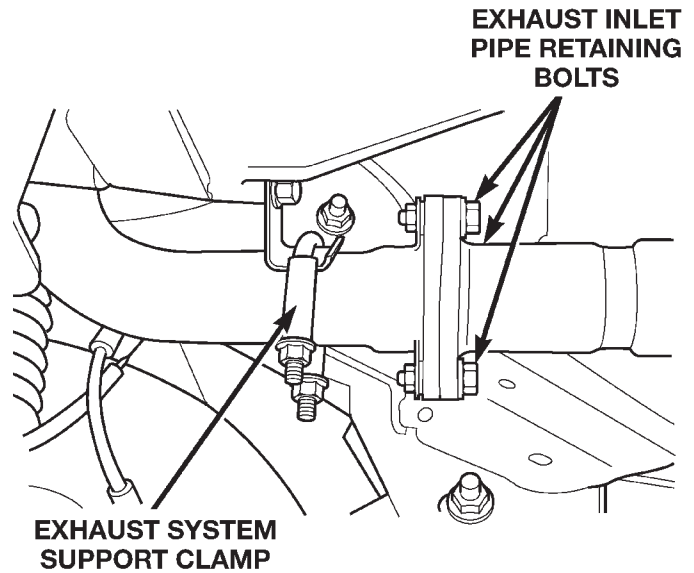

Fig. 4 Engine Compartment

- (3) Remove the air filter cover and hose from turbocharger, remove the assembly (Fig. 4).
- (4) Remove the EGR vacuum supply hose from the EGR valve.
- (5) Remove the innercooler inlet and outlet hoses from the engine (Fig. 4).
- (6) Remove the (2) bolts holding the EGR tube to the EGR valve.
- (7) Remove the intake manifold elbow and EGR valve as an assembly.
- (8) Raise the vehicle on a hoist.
- (9) Drain the cooling system. Refer to Group 7, Cooling System for procedure.
- (10) Remove the exhaust system support clamp (Fig. 5).
- (11) Disconnect the exhaust system at the (3) bolt flange (Fig. 5).

CAUTION: Heatshield is very sharp. Wear gloves to prevent injury.

- (12) Unstrap the exhaust downpipe heatshield (Fig. 6).
- (13) Disconnect the turbocharger oil return hose from the engine block (Fig. 7).



80b9a496

Fig. 5 Exhaust System Inlet Pipe Connection

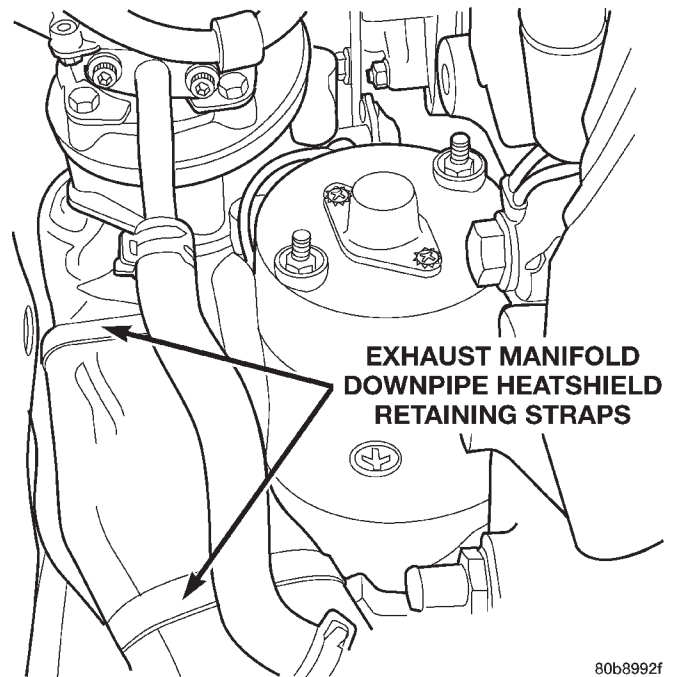

80b8992f

Fig. 6 Exhaust Downpipe Heatshield

- (14) Lower the vehicle from the hoist.
- (15) Remove the EGR tube from exhaust manifold.
- (16) Remove the (2) exhaust manifold heatshield retaining bolts and remove the heatshield.
- (17) Remove the heater core supply hoses from the vehicle.
- (18) Remove the oil pressure supply line bango bolt from the turbocharger.

REMOVAL AND INSTALLATION (Continued)

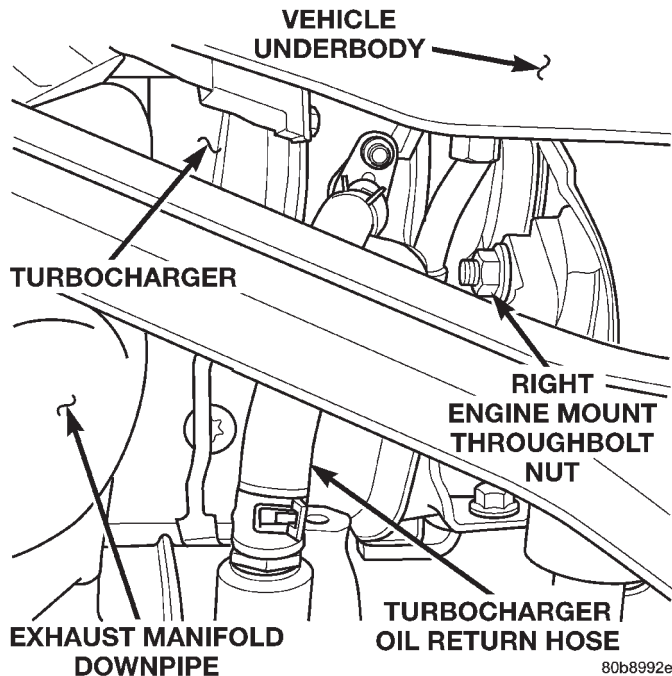

Fig. 7 Turbocharger Oil Return Hose

CAUTION: Heatshield is very sharp. Wear gloves to prevent injury.

(19) Remove the exhaust downpipe heatshield by pulling straight up.

(20) Remove the (5) bolts from exhaust manifold downpipe and remove pipe.

(21) Remove the (8) exhaust manifold retaining bolts, it is necessary to access the bolt behind the manifold outlet from the underneath of the vehicle.

(22) Remove the exhaust manifold and turbocharger assembly from the vehicle.

(23) Place assembly in a vice to remove the (3) exhaust manifold to turbocharger retaining nuts (Fig. 8).

Cleaning

All old gaskets should be inspected for any tears or signs of prior leakage. If any gaskets show such indications, they should be replaced with new gaskets. All gasket mating surfaces must be cleaned of old gasket material to produce a smooth and dirt free sealing surface for the new gasket.

INSTALLATION

(1) Transfer the oil return hose to the new turbocharger (Fig. 9).

(2) Install the turbo on the exhaust manifold (Fig. 9). Torque the nuts to 32 N·m (23 ft. lbs.).

(3) Install the exhaust manifold and turbocharger assembly in the vehicle.

(4) Install the (8) exhaust manifold retaining nuts. Torque nuts to 32 N·m (23 ft. lbs.).

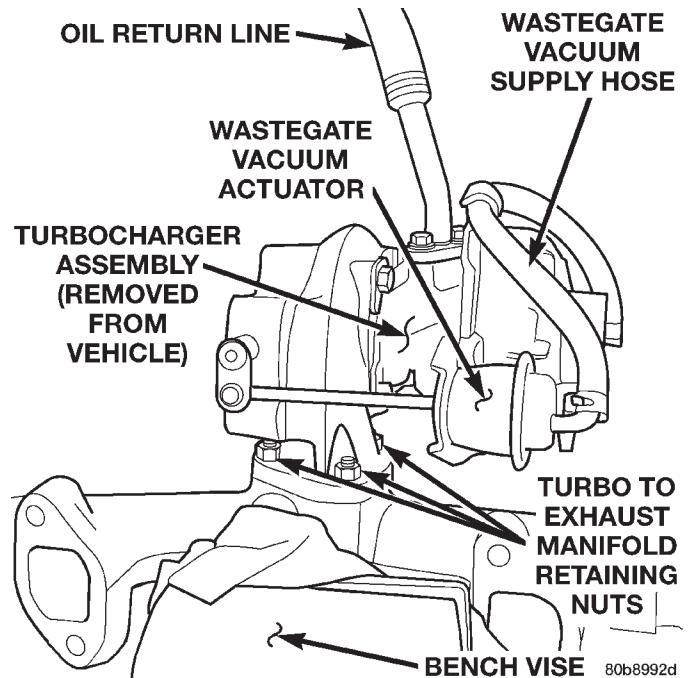

Fig. 8 Turbocharger / Exhaust Manifold Assembly

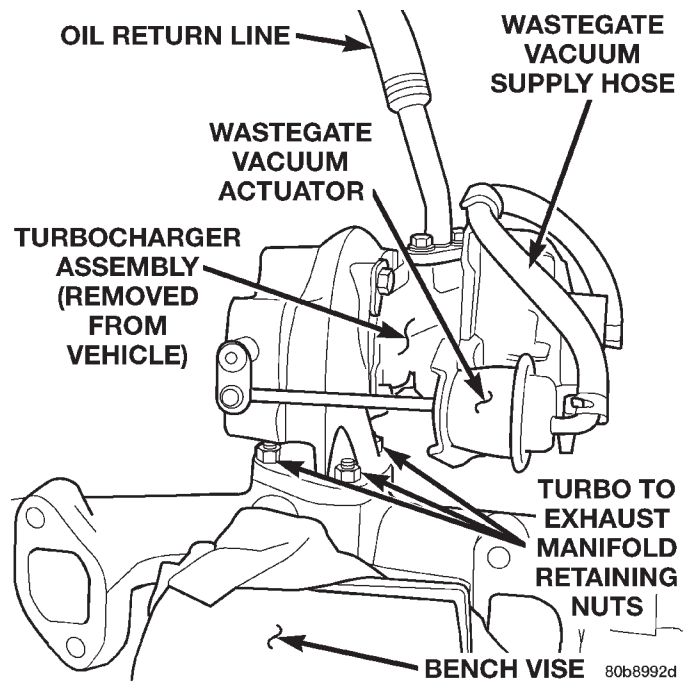

Fig. 9 Turbocharger / Exhaust Manifold Assembly

(5) Install the exhaust manifold downpipe. Torque bolts to 32 N·m (23 ft. lbs.).

CAUTION: Heatshield is very sharp. Wear gloves to prevent injury.

(6) Slide the exhaust downpipe heatshield down over pipe. Do not attempt to strap heatshield in position at this time, wait until vehicle is raised on hoist.

REMOVAL AND INSTALLATION (Continued)

- (7) Install the oil pressure supply line on turbocharger. Torque bango bolt fitting to 27 N·m (20 ft. lbs.).
- (8) Install the heater core supply hoses.
- (9) Position and install the exhaust manifold heatshield. Torque bolts to 11 N·m (97 in. lbs.).
- (10) Raise the vehicle on a hoist.
- (11) Install the turbocharger oil return hose on the engine block (Fig. 10).

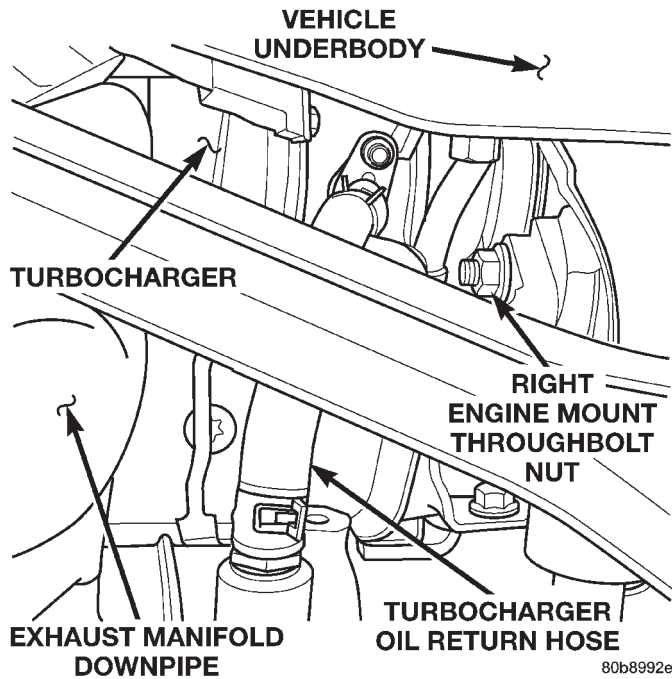
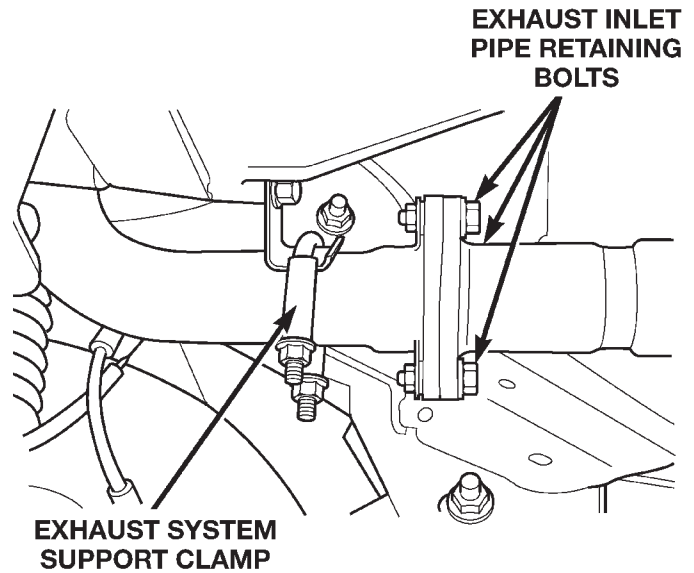

Fig. 10 Turbocharger Oil Return Hose

- (12) Strap the exhaust downpipe heatshield in its original position.
- (13) Connect the exhaust system at the (3) bolt flange (Fig. 11). Torque the bolts to 23 N·m (17 ft. lbs.).
- (14) Install the exhaust system support clamp (Fig. 11). Torque nuts to 23 N·m (17 ft. lbs.).
- (15) Lower the vehicle from the hoist.
- (16) Install the intake manifold elbow and EGR valve as an assembly. Torque bolts to 27 N·m (20 ft. lbs.).
- (17) Install the (2) bolts holding the EGR tube to the EGR valve. Torque bolts to 27 N·m (20 ft. lbs.).
- (18) Install the innercooler inlet and outlet hoses on the engine (Fig. 12).
- (19) Install the EGR vacuum supply hose on the EGR valve.
- (20) Install the air filter cover and outlet hose on turbocharger (Fig. 12).
- (21) Connect the breather hose on the air cleaner outlet hose (Fig. 12).
- (22) Fill the cooling system. Refer to Group 7, Cooling System for procedure.
- (23) Connect the negative battery cable



80b9a496

Fig. 11 Exhaust System Inlet Pipe Connection

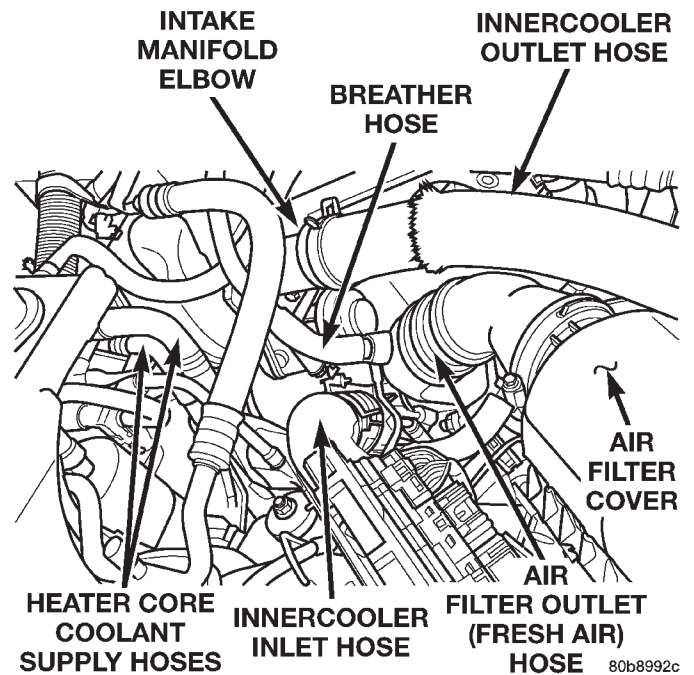

Fig. 12 Engine Compartment

- (24) Start the engine and check for leaks.

EXHAUST MANIFOLD AND TURBOCHARGER (RHD)

REMOVAL

- (1) Disconnect the negative battery cable.
- (2) Disconnect the breather hose from the air cleaner outlet hose.

REMOVAL AND INSTALLATION (Continued)

(3) Remove the air filter cover and the hose from the turbocharger, remove the assembly.

(4) Raise the vehicle on a hoist.

(5) Drain the cooling system. Refer to Group 7, Cooling System for the procedure.

(6) Remove the exhaust system support clamp (Fig. 13).

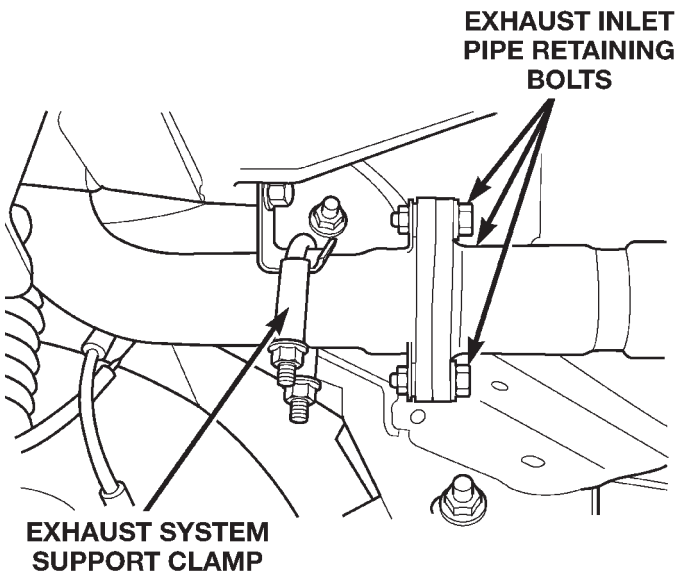

80b9a496

Fig. 13 Exhaust System Inlet Pipe Connection

(7) Disconnect the exhaust system at the (3) bolt flange (Fig. 13).

CAUTION: Heatshield is very sharp. Wear gloves to prevent injury.

(8) Unstrap the exhaust downpipe heatshield (Fig. 14).

CAUTION: Heatshield is very sharp. Wear gloves to prevent injury.

(9) Remove the exhaust downpipe heatshield by pulling straight down.

(10) Disconnect the turbocharger oil return hose from the engine block (Fig. 15).

(11) Lower the vehicle from the hoist.

(12) Disconnect the heater core coolant supply and the brake vacuum supply hoses from the right side of the engine. Remove the steel line support bracket from the top of the rocker cover and position the assembly out of the way.

(13) Remove the EGR vacuum supply hose from the EGR valve.

(14) Remove the innercooler inlet and outlet hoses from the engine.

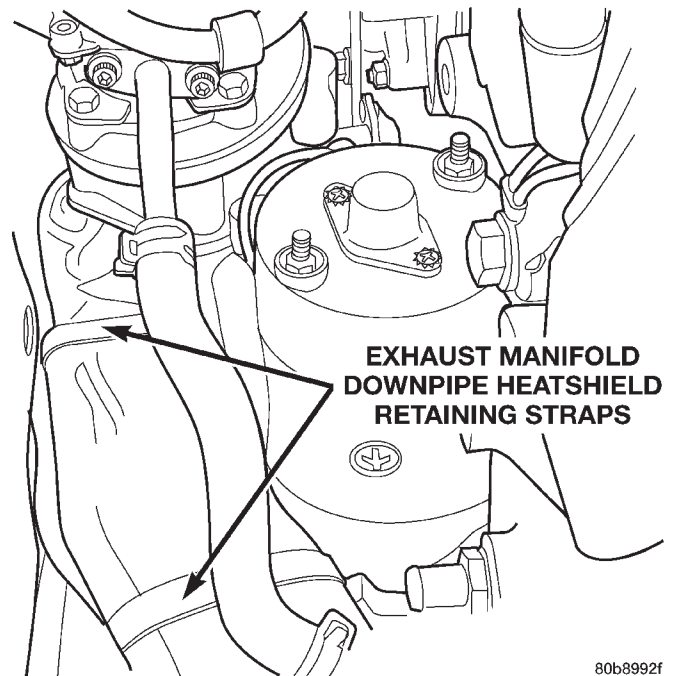

80b8992f

Fig. 14 Exhaust Downpipe Heatshield

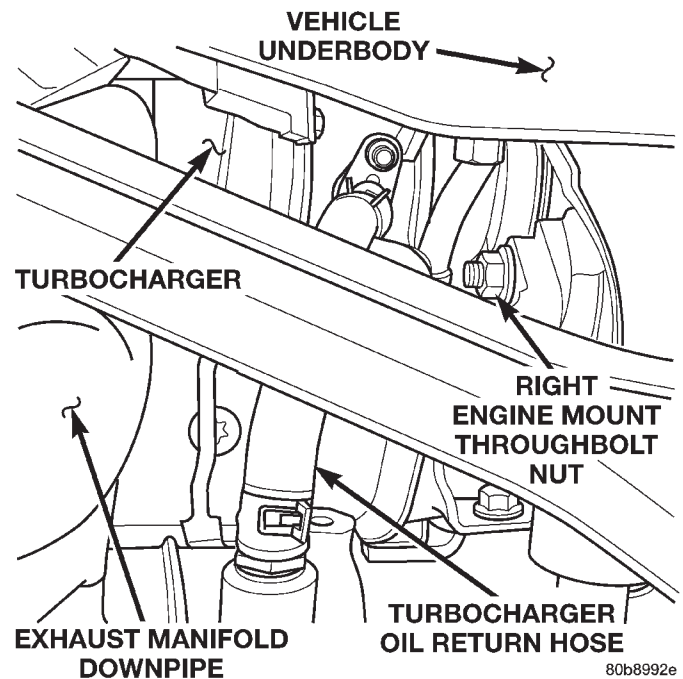

80b8992e

Fig. 15 Turbocharger Oil Return Hose

(15) Remove the (2) bolts holding the EGR tube to the EGR valve.

(16) Remove the intake manifold elbow and the EGR valve as an assembly.

(17) Remove the EGR tube from the exhaust manifold.

(18) Remove the (2) exhaust manifold heatshield retaining bolts and remove the heatshield (Fig. 16).

(19) Remove the oil pressure supply line from the turbocharger (Fig. 16).

REMOVAL AND INSTALLATION (Continued)

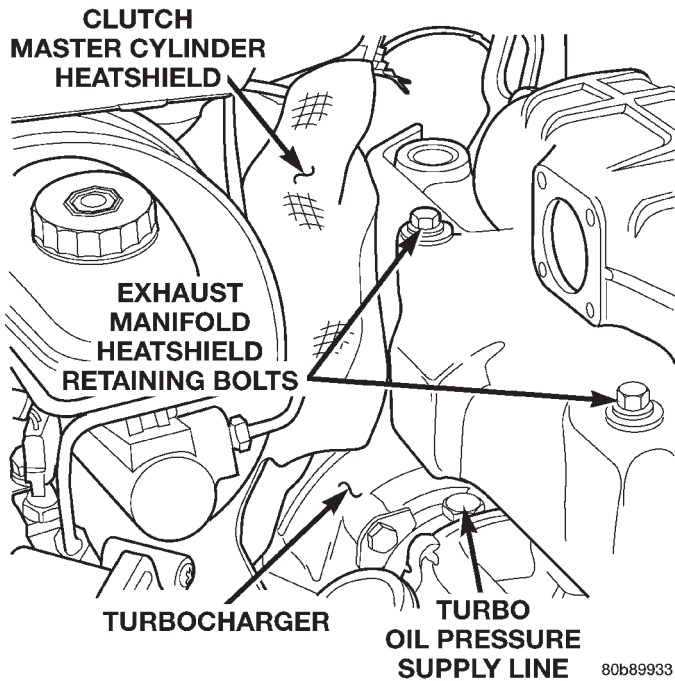

Fig. 16 2.5L Turbo Diesel — Heatshields

(20) Remove the clutch master cylinder heatshield (Fig. 16).

(21) Remove the wastegate actuator vacuum supply hose from the actuator (Fig. 17).

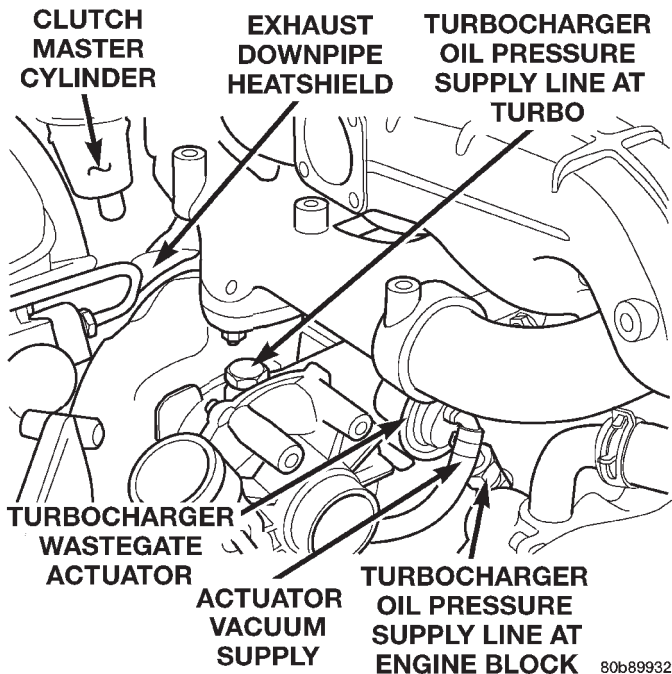

Fig. 17 R.H.D. Turbo Position & Orientation

(22) Remove the turbocharger oil pressure supply line from the engine block (Fig. 17).

(23) Working inside of the vehicle, remove the Knee Blocker. Refer to Group 8E, Instrument Panel Systems for the procedure.

(24) Disconnect the neutral safety switch electrical connector at the clutch pedal.

(25) Remove the (2) clutch master cylinder retaining nuts from the bulkhead.

(26) Working from the inside of the engine compartment, remove the clutch master cylinder from the bulkhead and position the cylinder and line assembly out of the way.

(27) Remove the (5) bolts from the exhaust manifold downpipe and remove the pipe.

(28) Remove the (8) exhaust manifold retaining bolts, it is necessary to access the bolt behind the manifold outlet from the underneath of the vehicle.

(29) Remove the steering shaft pinchbolt and slide the shaft straight off of the gearbox input shaft. Position aside.

(30) Remove the exhaust manifold and the turbocharger assembly from the vehicle.

(31) Place the turbo assembly in a vice to remove the (3) exhaust manifold to turbocharger retaining nuts (Fig. 18).

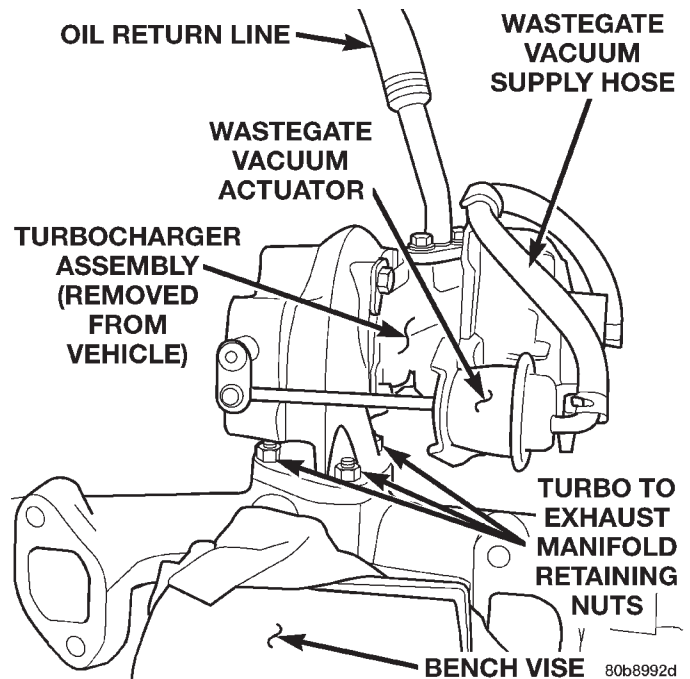

Fig. 18 Turbocharger / Exhaust Manifold Assembly Cleaning

All old gaskets should be inspected for any tears or signs of prior leakage. If any gasket shows such indications, it must be replaced with a new gasket. All gasket mating surfaces must be cleaned of all old gasket material to produce a smooth and dirt free sealing surface for the new gasket.

INSTALLATION

(1) Install the turbocharger on the exhaust manifold (Fig. 19). Torque nuts to 32 N·m (23 ft. lbs.).

REMOVAL AND INSTALLATION (Continued)

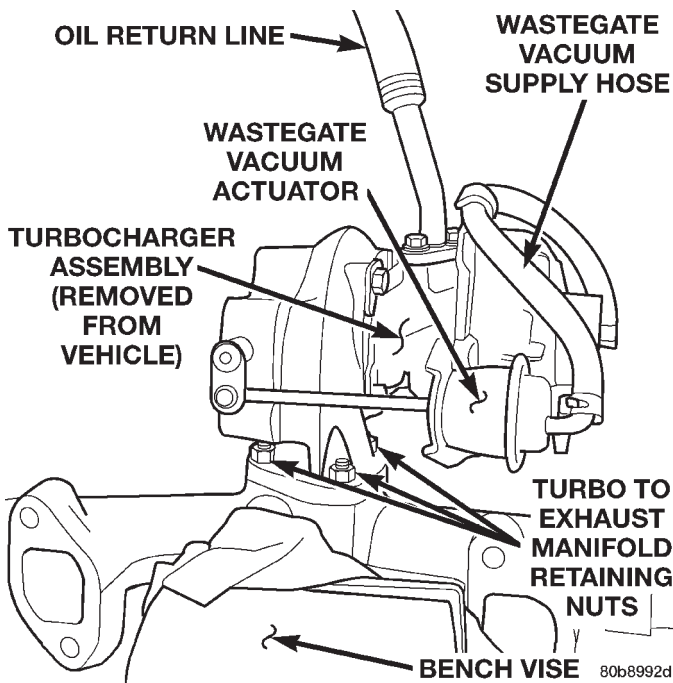

Fig. 19 Turbocharger / Exhaust Manifold Assembly

(2) Install the exhaust manifold and turbocharger assembly in the vehicle.

(3) Install the (8) exhaust manifold retaining nuts, it is necessary to access the bolt behind the manifold outlet from the underneath of the vehicle. Torque nuts to 32 N·m (23 ft. lbs.).

(4) Install the exhaust manifold downpipe. Torque the bolts to 32 N·m (23 ft. lbs.).

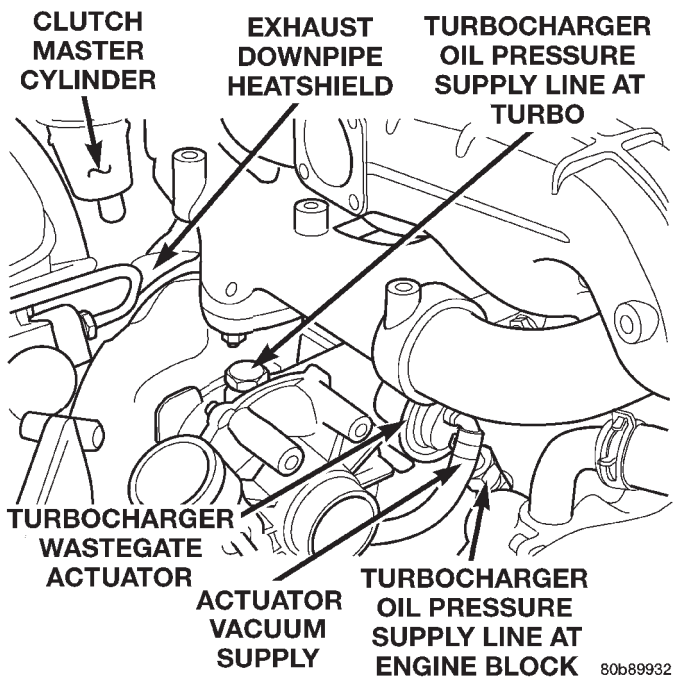

Fig. 20 R.H.D. Turbo Position & Orientation

(5) Position the turbocharger oil pressure supply line in its original position (Fig. 20). Torque the turbo fitting to 27 N·m (20 ft. lbs.).

(6) Install the wastegate actuator vacuum supply hose on the actuator (Fig. 20).

(7) Install the exhaust manifold heatshield (Fig. 21). Torque bolts to 11 N·m (97 in. lbs.).

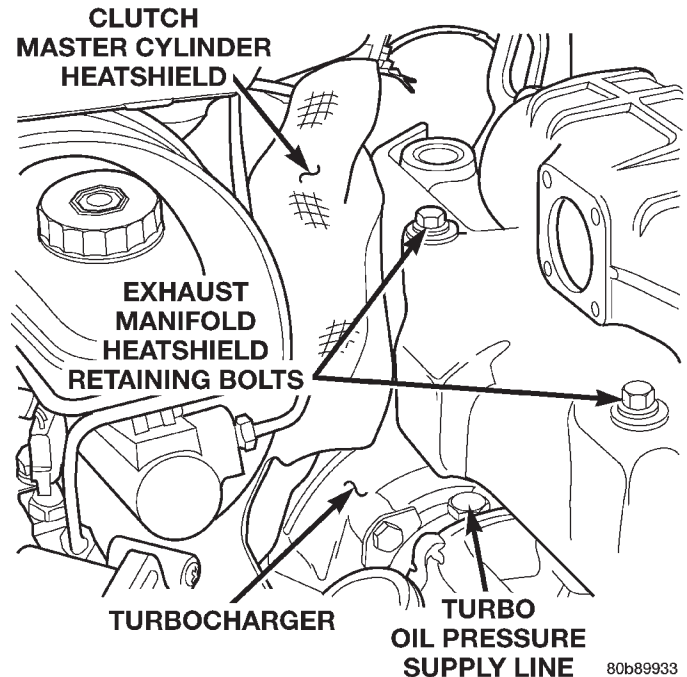

Fig. 21 2.5L Turbo Diesel — Heatshields

(8) Install the EGR tube on the exhaust manifold. Leave loose at this time.

(9) Raise the vehicle on a hoist.

CAUTION: Heatshield is very sharp. Wear gloves to prevent injury.

(10) Slide the exhaust downpipe heatshield up over the pipe and strap it in its original position (Fig. 22).

(11) Install the steering shaft. Torque the pinch bolt to 49 N·m (36 ft. lbs.).

(12) Install the turbocharger oil return hose on the engine block (Fig. 23).

(13) Connect the exhaust system at the (3) bolt flange (Fig. 24). Torque the bolts to 23 N·m (17 ft. lbs.).

(14) Install the exhaust system support clamp (Fig. 24). Torque nuts to 23 N·m (17 ft. lbs.).

(15) Lower the vehicle on hoist.

(16) Install the clutch master cylinder through the bulkhead.

(17) Working from the inside of the vehicle, Install the (2) clutch master cylinder retaining nuts.

(18) Connect the neutral safety switch at the clutch pedal.

REMOVAL AND INSTALLATION (Continued)

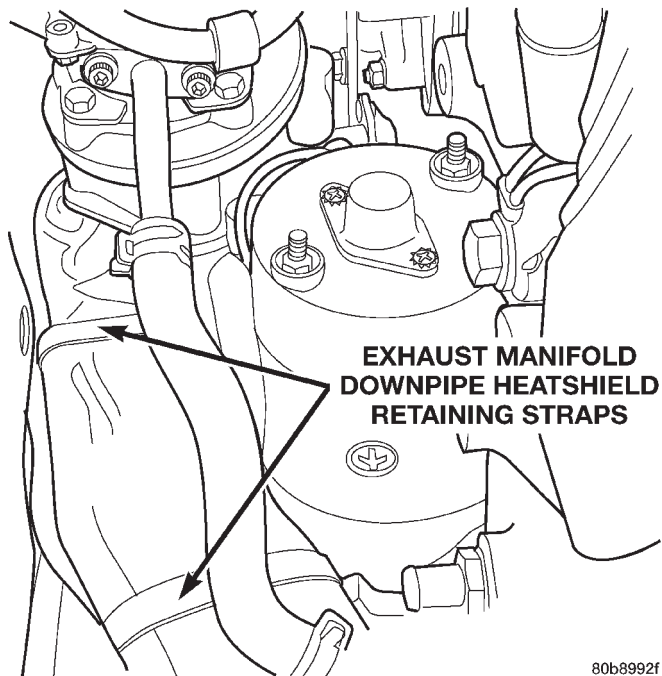

80b8992f

Fig. 22 Exhaust Downpipe Heatshield

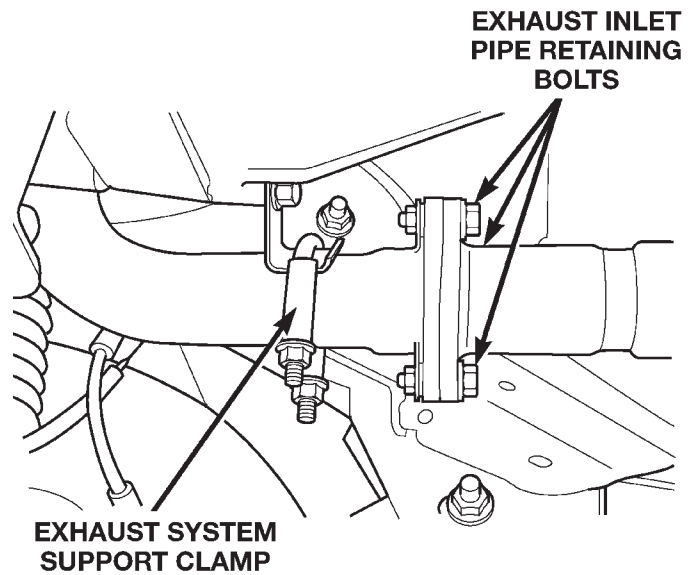

80b9a496

Fig. 24 Exhaust System Inlet Pipe Connection

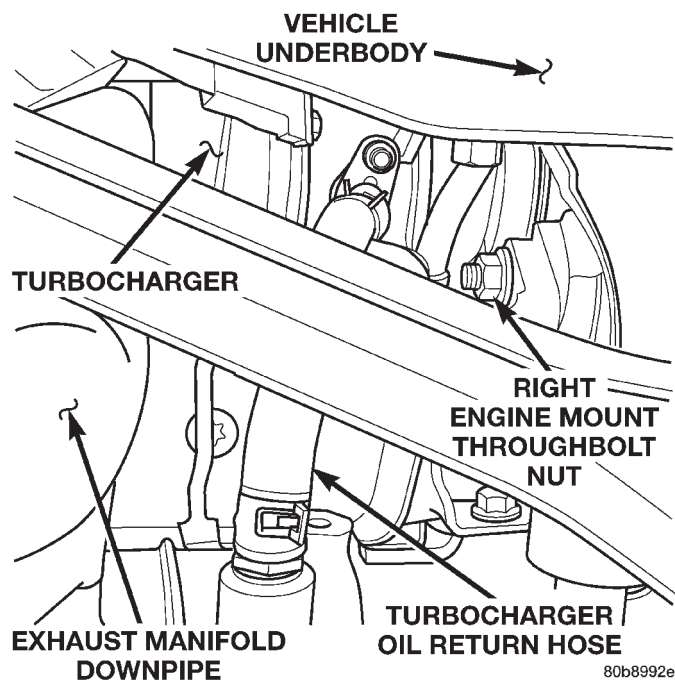

80b8992e

Fig. 23 Turbocharger Oil Return Hose

(19) Install the Knee Blocker. Refer to Group 8E, Instrument Panel Systems for procedure.

- (20) Install the clutch master cylinder heatshield.
- (21) Install the intake manifold elbow and the EGR valve as an assembly. Torque the intake elbow bolts to 27 N·m (20 ft. lbs.).
- (22) Install the (2) bolts holding the EGR tube to the EGR valve. Torque to bolts 27 N·m (20 ft. lbs.).
- (23) Torque the EGR tube on the exhaust manifold to 28 N·m (21 ft. lbs.).
- (24) Install the innercooler inlet and outlet hoses on the engine.
- (25) Install the EGR vacuum supply hose on the EGR valve.
- (26) Install the air filter cover and outlet hose on the turbocharger.
- (27) Connect the breather hose on the air cleaner outlet hose.
- (28) Install the heater core coolant supply and the brake vacuum supply lines in there original position.
- (29) Connect the negative battery cable.
- (30) Fill the cooling system. Refer to Group 7, Cooling System for the procedure.
- (31) Start the engine and check for leaks.

REMOVAL AND INSTALLATION (Continued)

INTAKE MANIFOLD

REMOVAL

- (1) Remove exhaust manifold and turbocharger assembly.
- (2) Remove water manifold.
- (3) Remove intake manifold.

CLEANING

Clean the intake manifold and cylinder head mating surfaces. **DO NOT allow foreign material to enter either the intake manifold or the ports in the cylinder head.**

INSTALLATION

- (1) Install the new intake manifold gasket.
- (2) Position the intake manifold in place and finger tighten the mounting nuts.
- (3) Tighten the fasteners in sequence and to the specified torque 30 N·m.
- (4) Position the water manifold in place and finger tighten the mounting nuts.
- (5) Tighten the fasteners to the specified torque 12 N·m.
- (6) Install exhaust manifold and turbocharger assembly.
- (7) Install charge air cooler hose to intake manifold.
- (8) Connect the battery negative cable.
- (9) Start engine and check for leaks.

SPECIFICATIONS

TORQUE SPECIFICATIONS

Description	Torque
EGR	
Attaching Nuts	28 N·m
EGR	
Tube Nut	34 N·m
EGR	
Tube Flange Bolts	26 N·m
Exhaust Manifold	
Nuts	30 N·m
Exhaust Manifold	
Heat Shield Nuts	11 N·m
Exhaust Pipe	
Support Clamp Bolts	22.5 N·m
Exhaust Pipe	
Support Clamp Screw	22.5 N·m
Intake Manifold	
Nuts	30 N·m
Muffler-to-Exhaust Pipe	
Clamp Nuts	43 N·m
Tail Pipe Clamp	
Hanger bolt	22.5 N·m
Turbocharger-to-Exhaust manifold	
Nuts	27 N·m
Turbocharger	
Oil Feed Line	27.4 N·m
Turbocharger Down Pipe-to-Exhaust Pipe	
Bolts/Nuts	22.5 N·m
Turbocharger Down Pipe-to-Turbocharger	
Bolts	27 N·m