

BODY

CONTENTS

	page		page
BODY COMPONENT SERVICE	17	SEATS	10
GENERAL SERVICE INFORMATION	1	STATIONARY GLASS	4
PAINT	2		

GENERAL SERVICE INFORMATION

GENERAL INFORMATION

SAFETY PRECAUTIONS AND WARNINGS

WARNING: EYE PROTECTION SHOULD BE USED WHEN SERVICING GLASS COMPONENTS. PERSONAL INJURY CAN RESULT.

USE A OSHA APPROVED BREATHING FILTER WHEN SPRAYING PAINT OR SOLVENTS IN A CONFINED AREA. PERSONAL INJURY CAN RESULT.

AVOID PROLONGED SKIN CONTACT WITH PETROLEUM OR ALCOHOL – BASED CLEANING SOLVENTS. PERSONAL INJURY CAN RESULT.

DO NOT STAND UNDER A HOISTED VEHICLE THAT IS NOT PROPERLY SUPPORTED ON SAFETY STANDS. PERSONAL INJURY CAN RESULT.

CAUTION: When holes must be drilled or punched in an inner body panel, verify depth of space to the outer body panel, electrical wiring, or other components. Damage to vehicle can result.

Do not weld exterior panels unless combustible material on the interior of vehicle is removed from the repair area. Fire or hazardous conditions, can result.

Always have a fire extinguisher ready for use when welding.

Disconnect the negative (-) cable clamp from the battery when servicing electrical components that are live when the ignition is OFF. Damage to electrical system can result.

Do not use abrasive chemicals or compounds on painted surfaces. Damage to finish can result.

Do not use harsh alkaline based cleaning solvents on painted or upholstered surfaces. Damage to finish or color can result.

Do not hammer or pound on plastic trim panel when servicing interior trim. Plastic panels can break.

Chrysler Corporation uses many different types of push-in fasteners to secure the interior and exterior trim to the body. Most of these fasteners can be reused to assemble the trim during various repair procedures. At times, a push-in fastener cannot be removed without damaging the fastener or the component it is holding. If it is not possible to remove a fastener without damaging a component or body, cut or break the fastener and use a new one when installing the component. Never pry or pound on a plastic or pressed-board trim component. Using a suitable fork-type prying device, pry the fastener from the retaining hole behind the component being removed. When installing, verify fastener alignment with the retaining hole by hand. Push directly on or over the fastener until it seats. Apply a low-force pull to the panel to verify that it is secure.

When it is necessary to remove components to service another, it should not be necessary to apply excessive force or bend a component to remove it. Before damaging a trim component, verify hidden fasteners or captured edges holding the component in place.

PAINT

INDEX

	page	page
GENERAL INFORMATION		
BASE COAT/CLEAR COAT FINISH	2	
PAINT CODE	2	
PAINTED SURFACE TOUCH-UP	2	
		WET SANDING, BUFFING, AND POLISHING 2
		SPECIFICATIONS
		AFTERMARKET PAINT REPAIR PRODUCTS 3

GENERAL INFORMATION

PAINT CODE

Exterior vehicle body colors are identified on the Body Code plate. The plate is located on the left side of the dash panel in the engine compartment. Refer to the Introduction section at the front of this manual for body code plate description. The paint code is also identified on the Vehicle Safety Certification Label which is located on the drivers door shut face. The color names provided in the Paint and Trim Code Description chart are the color names used on most repair product containers.

BASE COAT/CLEAR COAT FINISH

On most vehicles a two-part paint application (base coat/clear coat) is used. Color paint that is applied to primer is called base coat. The clear coat protects the base coat from ultraviolet light and provides a durable high-gloss finish.

WET SANDING, BUFFING, AND POLISHING

Minor acid etching, orange peel, or smudging in clear coat or single-stage finishes can be reduced with light wet sanding, hand buffing, and polishing. **If the finish has been wet sanded in the past, it cannot be repeated. Wet sanding operation should be performed by a trained automotive paint technician.**

CAUTION: Do not remove clear coat finish, if equipped. Base coat paint must retain clear coat for durability.

PAINTED SURFACE TOUCH-UP

When a painted metal surface has been scratched or chipped, it should be touched-up as soon as possible to avoid corrosion. For best results, use Mopar® Scratch Filler/Primer, Touch-Up Paints and Clear Top Coat. Refer to Introduction group of this manual for Body Code Plate information.

TOUCH-UP PROCEDURE

(1) Scrape loose paint and corrosion from inside scratch or chip.

(2) Clean affected area with Mopar® Tar/Road Oil Remover, and allow to dry.

(3) Fill the inside of the scratch or chip with a coat of filler/primer. Do not overlap primer onto good surface finish. The applicator brush should be wet enough to puddle-fill the defect without running. Do not stroke brush applicator on body surface. Allow the filler/primer to dry hard.

(4) Cover the filler/primer with color touch-up paint. Do not overlap touch-up color onto the original color coat around the scratch or chip. Butt the new color to the original color, if possible. Do not stroke applicator brush on body surface. Allow touch-up paint to dry hard.

(5) On vehicles without clear coat, the touch-up color can be lightly wet sanded (1500 grit) and polished with rubbing compound.

(6) On vehicles with clear coat, apply clear top coat to touch-up paint with the same technique as described in Step 4. Allow clear top coat to dry hard. If desired, Step 5 can be performed on clear top coat.

SPECIFICATIONS

AFTERMARKET PAINT REPAIR PRODUCTS

EXTERIOR COLOR

EXTERIOR COLOR	CHRY CODE *	PPG	DuPONT	S-W** M-S**	AKZO NOBEL SIKKENS	ICI**
Flame Red Clear Coat	PR4	4679	B9326	46916	CHA93:PR4	2NN6B
Chili Pepper Red	VEA	5361	B9823	54470	CHA98:VEA	HMT3B
Medium Fern Pearl Coat	RJP	4969	B9524	50270	CHA99:RJP	7CD6B
Forest Green Pearl Coat	SG8	5065	B9609	51062	CHA95:SG8	7MR8B
Intense Blue Pearl Coat	VB3	5357	B9822	54468	CHA98:VB3	HMR9B
Desert Sand	WTD	5474	B9884	56153	CHA99:WTD	KGC7B
Deep Amethyst Pearl Coat	TCN	5246	B9736	52026	CHA97:TCN	FNE4B
Black Clear Coat	DX8	9700	99	34858	CHA85:DX8	TC60B
Gunmetal Pearl Coat	TQ7	5248	B9735	52952	CHA97:TQ7	ERA9B
Stone White Clear Coat	SW1	83542	B9622	51539	CHA96:SW1	8KY5B

INTERIOR COLOR

INTERIOR COLOR	CHRY CODE*	PPG	DuPONT	S-W** M-S**	AKZO NOBEL SIKKENS	ICI**
Agate	AZ	9856 / 2-1461	C9208	45994	CHALAZI	7WC8
Camel / Dark Green	KG	N/A	N/A	N/A	N/A	K5/G8

NOTE: *Herberts Standox, Spies Hecker, and BASF use the Chrysler paint code as listed on the Body Code Plate and the Vehicle Safety Certification label. ** S-W = Sherwin-Williams, M-S = Martin Senour, ICI = ICI Autocolor.

STATIONARY GLASS

INDEX

	page		page
DESCRIPTION AND OPERATION		REAR DOOR STATIONARY WINDOW GLASS . . .	7
SAFETY PRECAUTIONS	4	REAR QUARTER WINDOW GLASS	8
REMOVAL AND INSTALLATION		WINDSHIELD	4
LIFTGATE GLASS	9		

DESCRIPTION AND OPERATION

SAFETY PRECAUTIONS

WARNING: DO NOT OPERATE THE VEHICLE WITHIN 24 HOURS OF WINDSHIELD INSTALLATION. IT TAKES AT LEAST 24 HOURS FOR URETHANE ADHESIVE TO CURE. IF IT IS NOT CURED, THE WINDSHIELD MAY NOT PERFORM PROPERLY IN AN ACCIDENT.

URETHANE ADHESIVES ARE APPLIED AS A SYSTEM. USE GLASS CLEANER, GLASS PREP SOLVENT, GLASS PRIMER, PVC (VINYL) PRIMER AND PINCH WELD (FENCE) PRIMER PROVIDED BY THE ADHESIVE MANUFACTURER. IF NOT, STRUCTURAL INTEGRITY COULD BE COMPROMISED.

CHRYSLER DOES NOT RECOMMEND GLASS ADHESIVE BY BRAND. TECHNICIANS SHOULD REVIEW PRODUCT LABELS AND TECHNICAL DATA SHEETS, AND USE ONLY ADHESIVES THAT THEIR MANUFACTURERS WARRANT WILL RESTORE A VEHICLE TO THE REQUIREMENTS OF FMVSS 212. TECHNICIANS SHOULD ALSO INSURE THAT PRIMERS AND CLEANERS ARE COMPATIBLE WITH THE PARTICULAR ADHESIVE USED.

BE SURE TO REFER TO THE URETHANE MANUFACTURER'S DIRECTIONS FOR CURING TIME SPECIFICATIONS, AND DO NOT USE ADHESIVE AFTER ITS EXPIRATION DATE.

VAPORS THAT ARE EMITTED FROM THE URETHANE ADHESIVE OR PRIMER COULD CAUSE PERSONAL INJURY. USE THEM IN A WELL-VENTILATED AREA.

SKIN CONTACT WITH URETHANE ADHESIVE SHOULD BE AVOIDED. PERSONAL INJURY MAY RESULT.

ALWAYS WEAR EYE AND HAND PROTECTION WHEN WORKING WITH GLASS.

CAUTION: Protect all painted and trimmed surfaces from coming in contact with urethane or primers.

Be careful not to damage painted surfaces when removing moldings or cutting urethane around windshield.

It is difficult to salvage a windshield during the removal operation. The windshield is part of the structural support for the roof. The urethane bonding used to secure the windshield to the fence is difficult to cut or clean from any surface. If the moldings are set in urethane, it would also be unlikely they could be salvaged. Before removing the windshield, check the availability of the windshield and moldings from the parts supplier.

REMOVAL AND INSTALLATION

WINDSHIELD

The windshield is positioned in the reveal molding and is bonded to the windshield frame with urethane adhesive.

Depending on the circumstances, either one of two windshield glass installation methods can be used:

- The short method.
- The extended method.

The short method is used when the windshield glass is removed intact, and the body opening and the pinchweld flanges do not require repair.

The extended method must be used when the body opening or a flange is damaged. The extended method must also be used when urethane no longer adheres to either the windshield glass or the pinchweld flanges.

REMOVAL

(1) Cover the interior and exterior body surface areas with a protective covering.

(2) Remove the windshield wiper arms and the rearview mirror.

(3) Using a razor knife, slide the blade between the windshield glass and the inboard edge of the reveal molding.

(4) Cut around the interior perimeter of the reveal molding and sever the cap of the reveal molding.

REMOVAL AND INSTALLATION (Continued)

(5) Using a cold knife, cut the urethane around the perimeter of the windshield (Fig. 1).

(6) Remove the windshield glass from the frame.

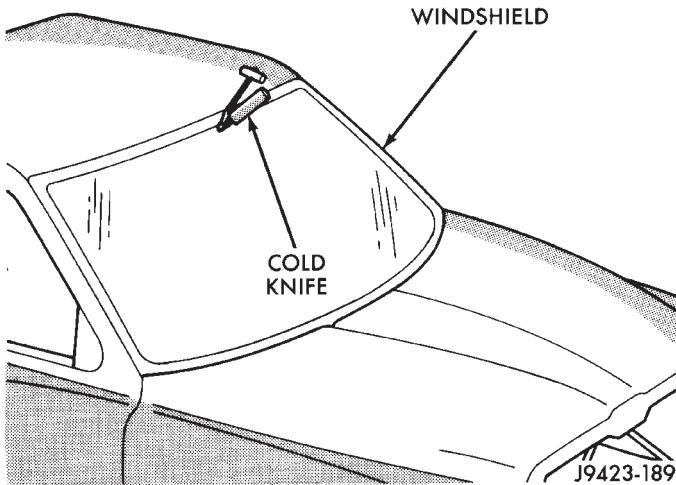

Fig. 1 Cutting Urethane Around Windshield—Typical INSTALLATION—SHORT METHOD

WARNING: REVIEW ALL WARNINGS AND CAUTIONS IN THIS GROUP BEFORE PRECEDING WITH INSTALLATION.

(1) Trim the urethane from the pinchweld flanges. Leave a 3 mm (0.1 in.) level base of urethane on the pinchweld flanges.

WARNING: DO NOT USE SOLVENT BASED GLASS CLEANER TO CLEAN WINDSHIELD BEFORE APPLYING GLASS PREP AND PRIMER. POOR ADHESION CAN RESULT.

(2) Clean inside of windshield with ammonia based glass cleaner and lint-free cloth.

(3) Prime outer perimeter of interior side of glass 16 mm (5/8 inch) from edge. Use a wipe-off type urethane primer and wipe glass dry after primer application.

NOTE: The reveal molding has an adhesive applied to the windshield contact surface to help secure the molding to the windshield during the installation procedure.

(4) Apply the molding to the windshield:

- With the molding at room temperature, press the molding onto the windshield corners.
- From corner to corner, work the molding to the center of each side. (Some stretching of the molding may be required during this procedure.)

(5) Place the glass on the pinchweld flanges and inspect for gaps in the urethane. Gaps in excess of 3 mm (1/8 inch) must be filled with urethane.

(6) Adjust windshield glass position until it is aligned with the flanges and adhesive.

(7) Using a grease pencil or equivalent, make alignment marks on the glass and body.

(8) Remove replacement windshield from windshield opening.

(9) Position the windshield inside up on a suitable work surface with two padded, wood 10 cm by 10 cm by 50 cm (4 in. by 4 in. by 20 in.) blocks, placed parallel 75 cm (2.5 ft.) apart (Fig. 2).

CAUTION: Avoid spilling or dripping primer on painted surfaces. Clean spills or drips immediately. The primer will damage the paint if it remains on the surface for any length of time.

(10) If the replacement windshield glass does not have blackout primer:

- Attach a 25 mm (1 in) wide masking tape band around the interior side of the glass 16 mm (5/8 in) from the edge of the glass (Fig. 3).

- Do not attach tape along the bottom of the glass and **attach it only to the inside of the glass.**

- Clean the 16-mm (5/8-in) wide surface area around the glass with isopropyl alcohol.

- Thoroughly mix and apply glass blackout primer to the 16 mm (5/8 in) surface area around the interior side of the glass (Fig. 4).

- Allow the primer to dry for at least 10-12 minutes.

(11) Apply a small amount of adhesive to the bottom support spacers and attach the support spacers to the bottom of the windshield, 170 mm inboard from the outer windshield edge (Fig. 5).

(12) Cut the urethane adhesive applicator nozzle (Fig. 6).

CAUTION: Be prepared to install the glass immediately after applying the adhesive, as the adhesive will begin to cure in less than 10 minutes.

(13) Apply a continuous, 6-mm (1/4-in) diameter bead of urethane adhesive to the surface area.

(14) Align the glass with the reference marks and position the glass on the pinchweld flanges. Ensure that the windshield glass is correctly seated on the support spacers.

(15) Force the windshield glass inward just enough to wet-out and set the urethane. Use care to avoid excessive squeeze-out of adhesive.

(16) Water test the windshield with a water spray after installation. Do not direct high pressure streams of water directly at urethane. If any leaks are detected, apply urethane as necessary.

(17) If used, remove the masking tape from the inner surface of the glass.

(18) Install all components and clean the vehicle.

REMOVAL AND INSTALLATION (Continued)

(19) Open the vehicle windows to prevent interior pressure while the urethane is curing. **If not vented, pressure in the interior of the vehicle may interfere with proper glass bonding.**

(20) Install the rearview mirror.

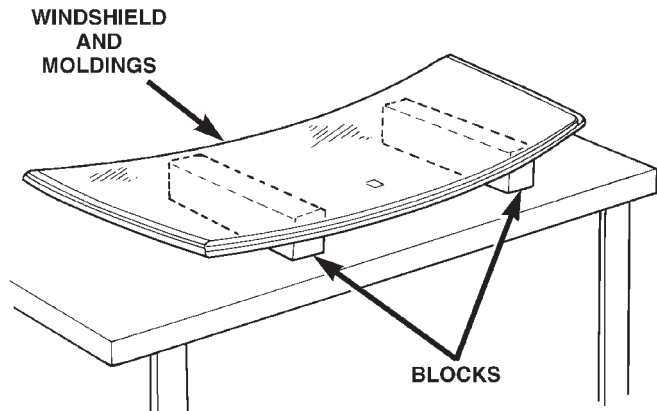

80a28c10

Fig. 2 Work Surface Set up

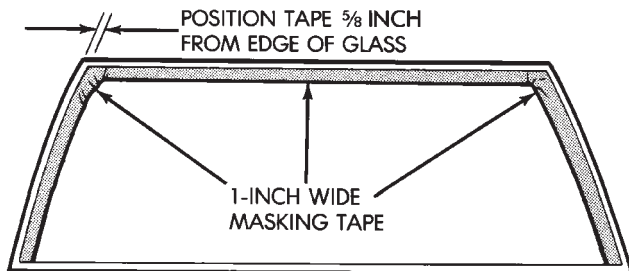

J8923-76

Fig. 3 Masking Tape Location For Blackout Primer INSTALLATION—EXTENDED METHOD

WARNING: REVIEW ALL WARNINGS AND CAUTIONS IN THIS GROUP BEFORE PRECEDING WITH INSTALLATION.

(1) Remove the all of urethane from all pinchweld flanges.

(2) Inspect and repair the windshield opening and pinchweld flanges.

(3) Prime the pinchweld flanges with a urethane base primer. However, if the flange is color-coated with paint, prime the flanges with a paint finish primer. **This is important because urethane adhesive will not adhere to all color-coat paints.** Allow primer sufficient time to dry.

NOTE: The reveal molding has an adhesive applied to the windshield contact surface to help secure the

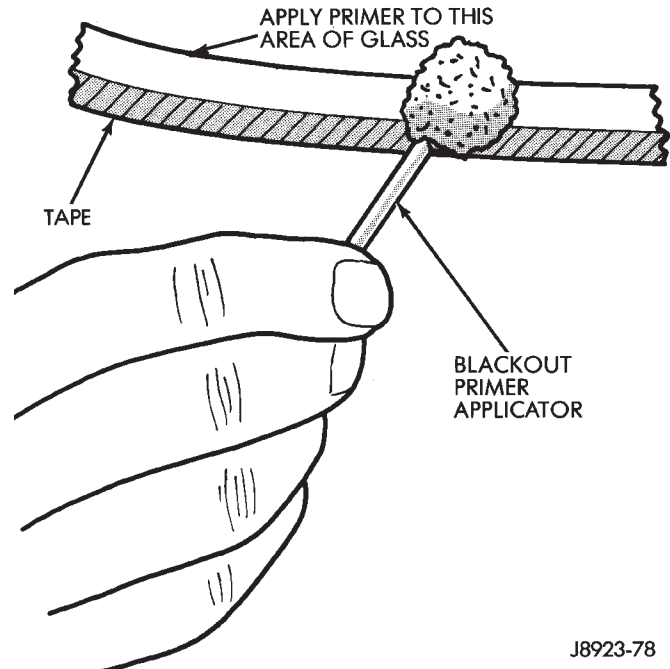

J8923-78

Fig. 4 Blackout Primer Application

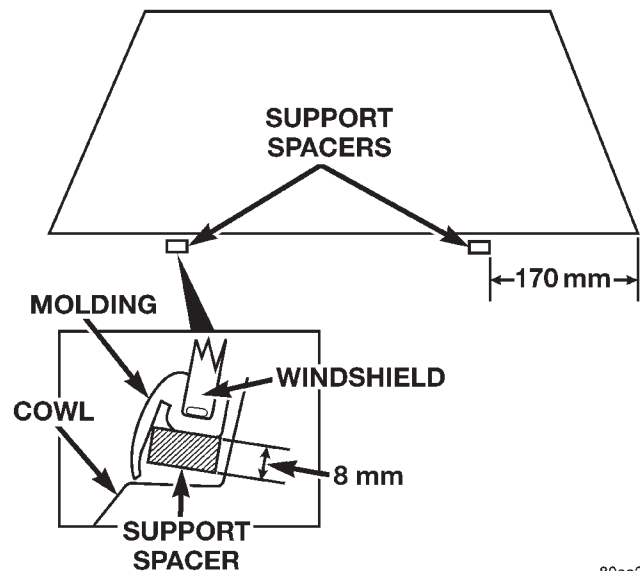

80ac2bd6

Fig. 5 Windshield Bottom Support Spacers molding to the windshield during the installation procedure.

(4) Apply the reveal molding to the windshield:

- With the molding at room temperature, press the molding onto the windshield corners.
- From corner to corner, work the molding to the center of each side. (Some stretching of the molding may be required during this procedure).

(5) Install and inspect the fit of the windshield on the pinchweld flanges as follows:

- Position windshield until it is aligned within windshield opening.

REMOVAL AND INSTALLATION (Continued)

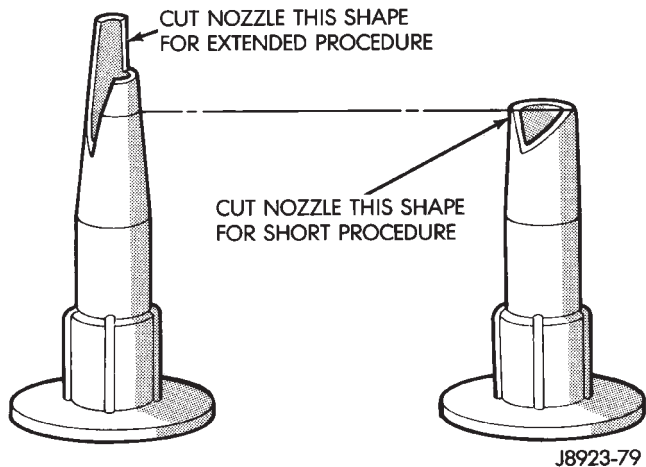

Fig. 6 Applicator Nozzle Preparation

- Measure the gap between the pinchweld flanges and glass around perimeter of the glass and flange.
 - The reveal molding should equally cover the A-Pillars on both sides.
 - The flanges should also extend above the glass edge equally around the perimeter of the opening.
- (6) If the pinchweld flanges require repair, remove the windshield glass and straighten, align, or repair the flange(s) as necessary.

(7) Position the windshield in the opening and inspect the windshield fit again. Mark the windshield final position on the glass and body with a wax pencil (or use masking tape). The marks (or masking tape) will be used for installation alignment reference.

(8) If the replacement windshield does not have blackout primer:

- Attach a 25-mm (1-in) wide masking tape band around the interior side of glass 16 mm (5/8 in) from edge of glass (Fig. 3).
- Do not attach tape along the bottom of the glass and **attach only to the inside of glass**.
- Thoroughly mix and apply blackout primer to the 16 mm (5/8 in) surface area around the interior side of the glass (Fig. 4).
- Allow the primer to dry for at least 10-12 minutes.

(9) Apply a small amount of adhesive to the bottom support spacers and attach the support spacers to the bottom of the windshield, 170 mm inboard from the outer windshield edge (Fig. 5).

(10) Cut the urethane applicator nozzle (Fig. 6).

(11) Apply a continuous bead of urethane to the surface area with blackout primer on the interior side of glass. The bead should be 9-mm (3/8-in) wide by 12.7-mm (1/2-in) deep for best results.

CAUTION: Be prepared to install the glass immediately after applying the adhesive, as the adhesive will begin to cure in less than 10 minutes.

(12) Align the windshield with the wax pencil installation alignment reference marks (or the tape strips). Position the windshield on pinchweld flanges and spacers.

(13) Force the windshield inward just enough to wet-out and set the urethane. Use care to avoid excessive squeeze-out of adhesive.

(14) Water test the windshield with a water spray after installation. Do not direct high pressure streams of water directly at the urethane. If any leaks are detected, apply urethane as necessary.

(15) If used, remove the masking tape from the inner surface of glass.

(16) Install all components and clean the vehicle. If necessary, refer to the installation procedures.

(17) Open the vehicle windows to prevent interior pressure while the urethane adhesive is curing. **If not vented, pressure in the interior of vehicle will interfere with glass bonding.**

(18) Install the rearview mirror on the bracket.

REAR DOOR STATIONARY WINDOW GLASS

REMOVAL

The rear door stationary window glass is bonded to the division bar and is serviced as an assembly.

- (1) Lower the window glass.
- (2) Remove the inner and outer beltline weatherstrip.
- (3) Remove the trim panel and waterdam from door inner panel.
- (4) Remove the screws attaching the division bar/glass to the door (Fig. 7).
- (5) Tilt the division bar/glass forward and remove it from the door.

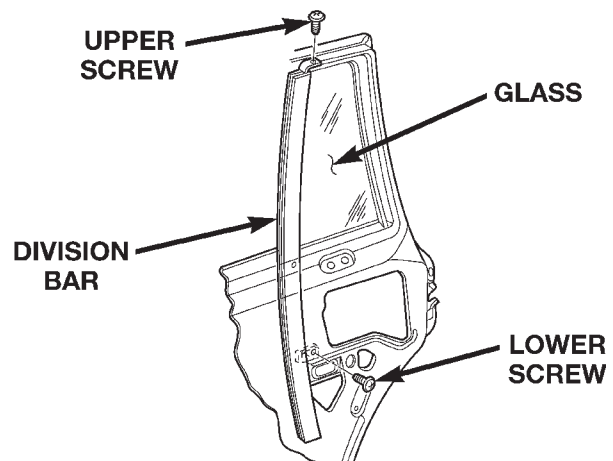

Fig. 7 Division Bar/Stationary Glass

REMOVAL AND INSTALLATION (Continued)

INSTALLATION

- (1) Position the division bar/glass in the door.
- (2) Install the screws attaching the division bar/glass to the door. Finger tighten the screws.
- (3) Tighten the upper screw to 6 N·m (5 ft-lbs) torque.
- (4) Tighten the lower screw to 6 N·m (5 ft-lbs) torque.
- (5) Install the beltline weatherstrip.
- (6) Install the door waterdam and trim panel.

REAR QUARTER WINDOW GLASS

REMOVAL

- (1) If equipped, remove the quarter window reveal molding (Fig. 8).
- (2) Remove the quarter window interior trim covers.
- (3) Separate the weatherstrip seal lip from the window opening flanges. Use a pry tool and carefully push the window glass and seal outward.
- (4) Remove the weatherstrip seal and window glass from window opening.
- (5) Remove the weatherstrip seal from the window glass.

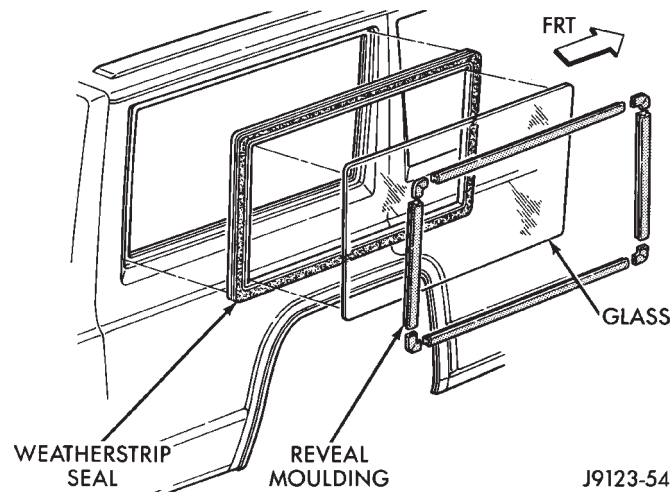

J9123-54

Fig. 8 Quarter Window Reveal Molding, Glass and Seal

INSTALLATION

- (1) Clean the original sealant from the weatherstrip channels and window opening flanges.
- (2) Apply a 4-mm (1/6-in) diameter bead of sealant to the window channel in the weatherstrip seal.
- (3) Install the weatherstrip on the window glass. Install the seal installation cord in the window opening flange channel (Fig. 9) as follows:
 - Moisten a length of 6-mm (1/4-in) diameter cord with a soap and water solution.
 - Ensure that the cord is long enough to go all the way around the perimeter of the weatherstrip.

- Insert the cord into the window opening flange channel in the weatherstrip seal.

- (4) Apply a 6-mm (1/4-in) diameter bead of sealant to the window opening flanges.

- (5) For two-door vehicles, apply a 3-mm (1/8-in) diameter bead of sealant at the quarter panel applique and liftgate pillar seam.

- (6) Position the quarter window glass and the weatherstrip seal in the window opening (Fig. 10) with the free ends of the cord inside the vehicle (Fig. 11).

- (7) Pull on each end of the cord to pull the weatherstrip seal channel lip over the window opening flanges.

- (8) Test the vent window for water leaks.

- (9) Install the interior trim cover.

- (10) If equipped, install the quarter window reveal molding.

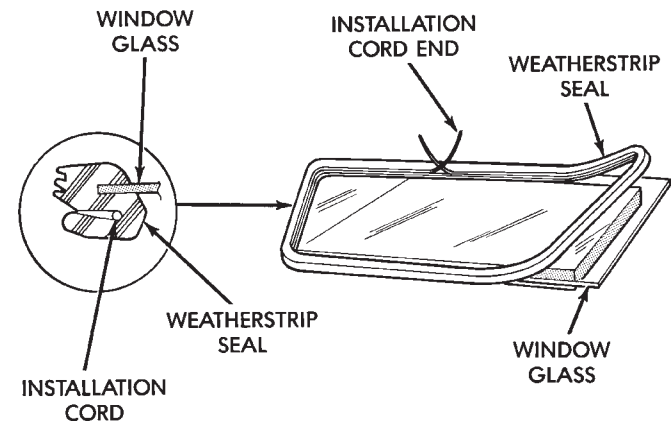

J9223-118

Fig. 9 Weatherstrip Seal and Cord Installation

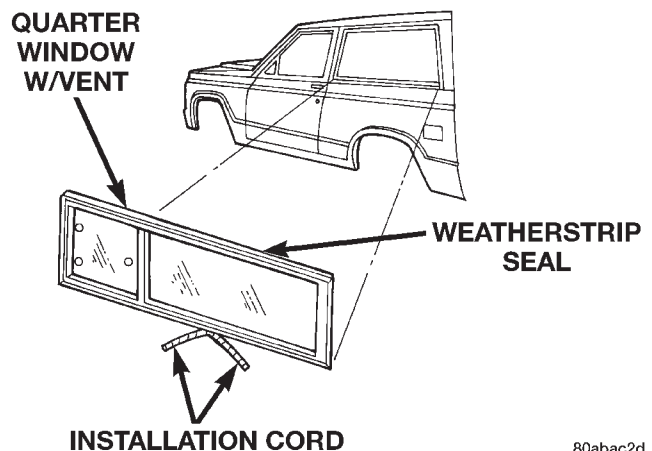

80abac2d

Fig. 10 Quarter Window With Vent

REMOVAL AND INSTALLATION (Continued)

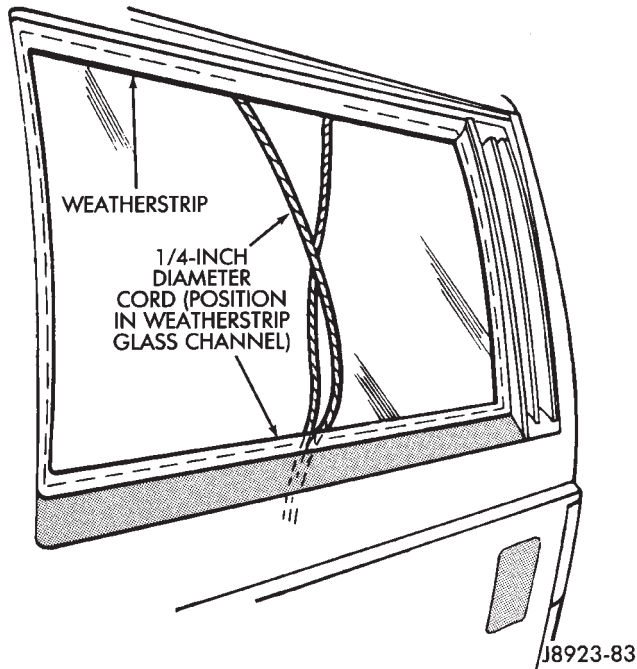

Fig. 11 Quarter Window Glass and Seal Installation
LIFTGATE GLASS

REMOVAL

- (1) Open liftgate.
- (2) Remove liftgate trim panel.
- (3) Disconnect heated backlite (HBL) connector.
- (4) Remove wiper arm.
- (5) Remove CHMSL lens.
- (6) Using a razor knife, slide the blade between the liftgate glass and the inboard edge of the reveal molding.
- (7) Cut around the interior perimeter of the reveal molding and sever the cap of the reveal molding.
- (8) Using a cold knife, cut urethane bonding from around liftgate glass. A pneumatic cutting device can be used if available.
- (9) Separate glass from Liftgate.

INSTALLATION

CAUTION: Open a window before installing glass. This will avoid pressurizing the passenger compartment. If a door or liftgate is slammed before urethane is cured, water leaks can result.

- (1) Trim the urethane from the liftgate glass opening flanges. Leave a 3 mm (0.1 in.) level base of urethane on the flanges.

- (2) Starting in the corners, press reveal molding onto glass.

- (3) Place replacement glass into liftgate opening and position glass in the center of the opening against flange.

- (4) Verify the glass lays evenly against the fence at the sides, top and bottom. If not, the flange must be formed to the shape of the new glass.

- (5) Using a grease pencil or equivalent, make reference marks on the glass and body.

- (6) Remove replacement glass from liftgate opening.

- (7) Position the glass inside up on a suitable work surface.

WARNING: DO NOT USE SOLVENT BASED GLASS CLEANER TO CLEAN WINDSHIELD BEFORE APPLYING GLASS PREP AND PRIMER. POOR ADHESION CAN RESULT.

- (8) Clean inside of glass with Mopar Glass Cleaner and lint-free cloth.

- (9) Apply PVC (vinyl) primer 25 mm (1 in.) wide around edge of glass. Wipe with clean/dry lint-free cloth.

- (10) If necessary, apply fence primer around edge of fence. Allow at least eighteen minutes drying time.

- (11) Apply a 10 mm (0.4 in.) bead of urethane around glass border.

- (12) Position glass into liftgate opening and reference marks.

- (13) Push the glass inward until the reveal molding is seated onto the liftgate frame. Use care to avoid excessive squeeze-out of adhesive.

- (14) Open windows to prevent pressure build-up while the urethane is curing.

- (15) Apply 150 mm (6 in.) lengths of 50 mm (2 in.) masking tape spaced 250 mm (10 in.) apart to hold glass in place until urethane cures.

- (16) Install the wiper arm.

- (17) Install CHMSL lens.

- (18) Connect heated backlite (HBL) connector.

- (19) After urethane has cured, remove tape strips and water test to verify repair.

- (20) Install liftgate trim panel.

SEATS

INDEX

	page		page
REMOVAL AND INSTALLATION			
BUCKET SEAT	11	HEAD RESTRAINT SLEEVE	10
BUCKET SEAT CUSHION COVER	13	REAR SEAT CUSHION	14
BUCKET SEAT PLATFORM	12	REAR SEAT CUSHION COVER	15
BUCKET SEAT RECLINER	14	REAR SEATBACK	15
BUCKET SEAT TRACK	12	REAR SEATBACK COVER	16
BUCKET SEATBACK	13	REAR SEATBACK LATCH STRIKER AND	
BUCKET SEATBACK COVER	12	BUMPER	15
HEAD RESTRAINT COVER	11	SPECIAL TOOLS	
		SEATS	16

REMOVAL AND INSTALLATION

HEAD RESTRAINT SLEEVE

REMOVAL

NOTE: When replacing a head restraint sleeve, the retaining tabs on the sleeve will be damaged during the removal process. Check the availability of replacement parts before servicing.

- (1) Raise head restraint to the full up position.
- (2) Turn head restraint lock thumbwheel to release head restraint and pull head restraint upward to remove from seat back.
- (3) Insert head restraint sleeve extractor (special tool 6773) (Fig. 1) and (Fig. 2) into the seat back.
- (4) The retaining tabs are positioned on each side of the sleeve, when inserting the extractor, ensure that the flat of the collar is facing the side of the seatback (Fig. 3).
- (5) Using a small hammer, tap extractor downward to release sleeve retaining tab.
- (6) Remove extractor tool from sleeve, rotate tool 180 degrees (Fig. 4) and repeat steps 3 and 4.
- (7) Remove extractor tool from sleeve and remove sleeve from seat back.

INSTALLATION

- (1) Position the sleeve in the seat back.
- (2) Firmly, push sleeve down to snap into place.
- (3) Install head restraint.

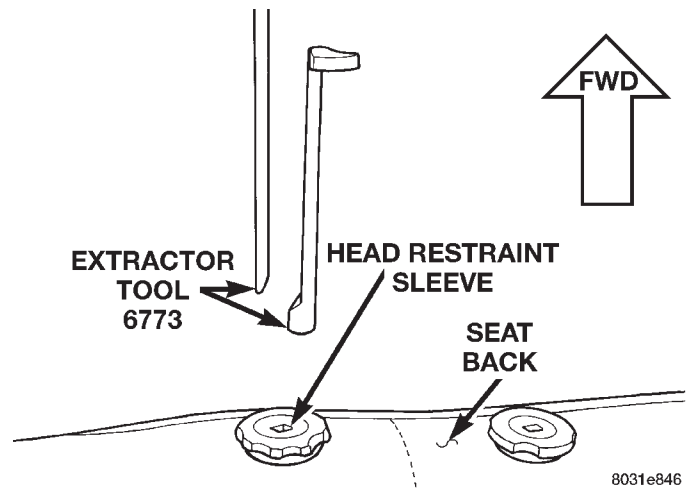

Fig. 1 Head Restraint Sleeve Extractor

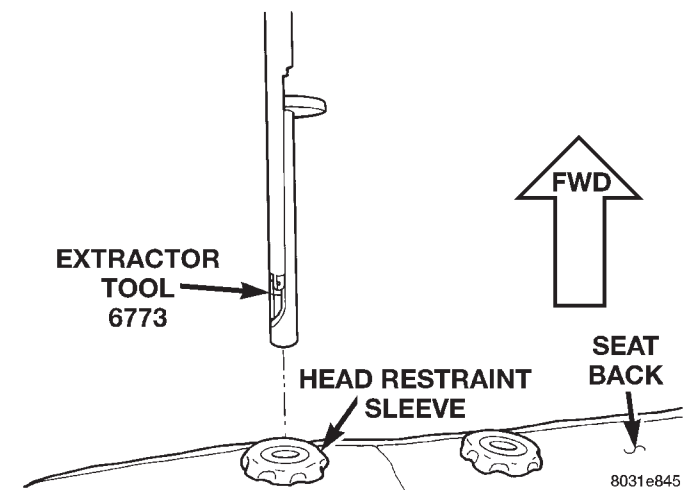

Fig. 2 Head Restraint Sleeve Extractor Installation

REMOVAL AND INSTALLATION (Continued)

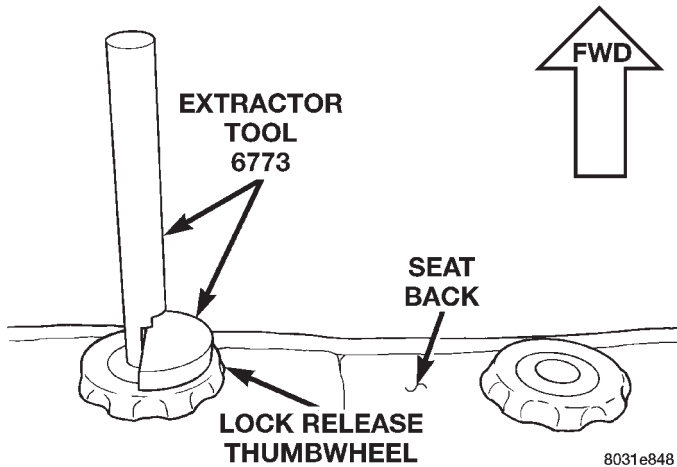

Fig. 3 Head Restraint Sleeve Extractor Positioning

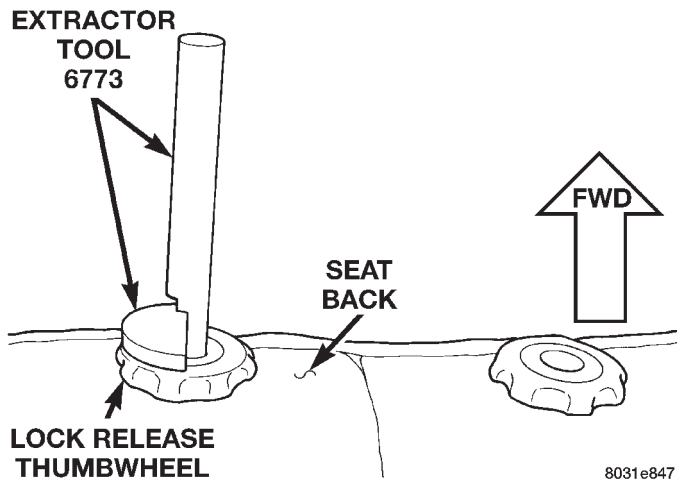

Fig. 4 Head Restraint Sleeve Extractor Positioning

REMOVAL

- (1) Remove head restraint from the bucket seat.
- (2) Remove the screws attaching the bezel and adjuster bar to the head restraint (Fig. 5).
- (3) Pull the adjuster bar from the head restraint.
- (4) Roll the cover upward and separate from the head restraint cushion (Fig. 6).

INSTALLATION

- (1) Position the cover on the head restraint cushion and roll the cover downward.
- (2) Position the adjuster bar in the head restraint.
- (3) Install the screws attaching the bezel and adjuster bar to the head restraint.
- (4) Install head restraint in the bucket seat.

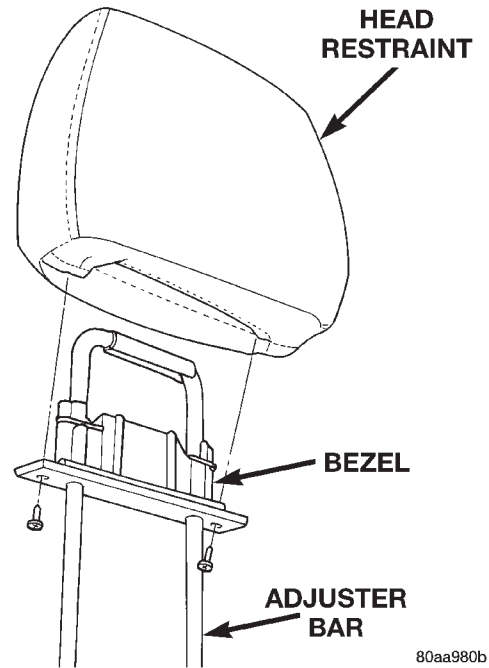

Fig. 5 Head Restraint

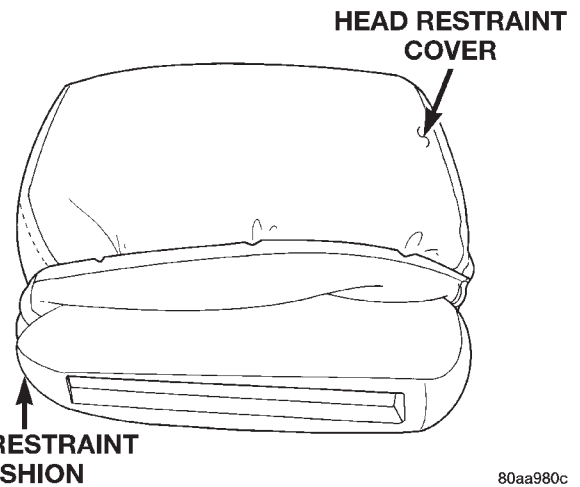

Fig. 6 Head Restraint Cover

BUCKET SEAT

REMOVAL

- (1) Remove bolts attaching seat to floor pan (Fig. 7).
- (2) Remove nut attaching seat to floor pan.
- (3) For power seat, disconnect wire harness connector. If equipped, disconnect wire harness for heated seat.
- (4) Disconnect seat belt buckle warning wire harness connector.
- (5) Separate seat from floor panel.

INSTALLATION

- (1) Position seat on floor pan.

REMOVAL AND INSTALLATION (Continued)

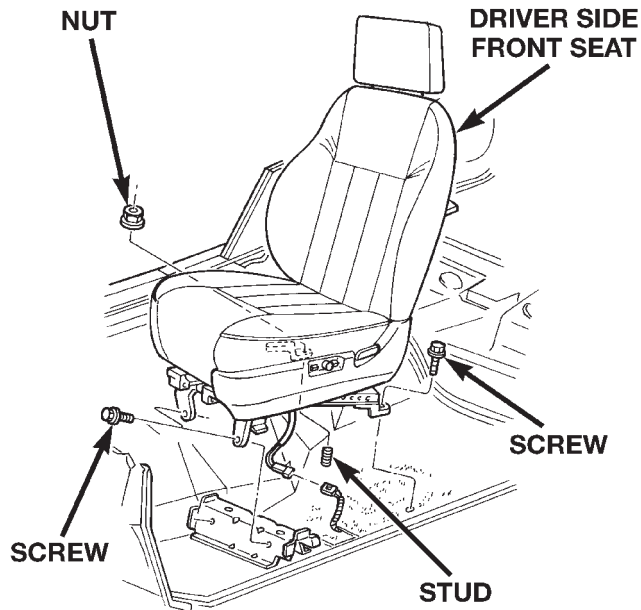

80abd26f

Fig. 7 Bucket Seat—Power Seat

- (2) Connect seat belt buckle warning wire harness connector.
- (3) For power seats, connect wire harness connector. If equipped, connect harness for heated seat.
- (4) Install front fasteners attaching seat to floor pan. Tighten to 27 N·m (20 ft. lbs.) torque.
- (5) Install rear fasteners attaching seat to floor pan. Tighten to 27 N·m (20 ft. lbs.) torque.
- (6) Install nut attaching seat to floor pan. Tighten to 40 N·m (30 ft. lbs.) torque.

BUCKET SEAT TRACK**REMOVAL**

NOTE: If the vehicle is equipped with manually adjusted bucket seats, the inboard or outboard seat track may be serviced separately.

- (1) Remove bucket seat from vehicle.
- (2) Remove screws attaching the side shield trim cover from the seat.
- (3) If equipped, disengage the power seat connector from the power seat switch.
- (4) Remove the nuts attaching the seat track to the bucket seat platform.
- (5) When separating the seat track from the platform, route the power seat switch connector through the access hole in the seat cushion frame, if equipped.

INSTALLATION

- (1) While positioning the seat track on the bucket seat platform, route the power seat switch connector through the access hole in the seat cushion frame, if equipped.
- (2) Install the nuts attaching the seat track to the bucket seat platform.
- (3) If equipped, engage the power seat connector to the power seat switch.
- (4) Install screws attaching the side shield trim cover to the seat.
- (5) Install bucket seat.

BUCKET SEAT PLATFORM

Bucket seat platforms are not repairable. If the seat platform is damaged, replace platform as a unit.

BUCKET SEATBACK COVER**REMOVAL**

- (1) Remove head restraint, if equipped.
- (2) Remove screws attaching side shield trim cover to bucket seat.
- (3) If equipped, disengage power seat wire connector from power seat switch.
- (4) Remove the inboard seatback pivot bolt.
- (5) Position the seatback in the full forward or full recline position.
- (6) Remove the seatback cover zipper from the base of the seatback.
- (7) Disengage the cover zipper and route the zipper end between the inboard seatback and seat cushion frame.
- (8) Roll the seatback cover upward (Fig. 8).
- (9) Disengage the hogrings attaching the seatback cover to the seatback cushion support wires (Fig. 9).
- (10) Roll the seatback cover upward and disengage the hook and loop fastener (Fig. 10).
- (11) Roll seatback cover up and over the head restraint sleeves, if equipped and separate from the seatback.

INSTALLATION

- (1) Position the seatback cover on the seatback cushion and roll seatback cover down over the head restraint sleeves. Route the sleeves through the access holes in the cover, if equipped.
- (2) Roll the seatback cover downward and engage the hook and loop fastener.
- (3) Continue rolling the cover downward and engage the hogrings attaching the seatback cover to the seatback cushion support wires.
- (4) Route the zipper end between the inboard seatback and seat cushion frame and engage the cover zipper.
- (5) Install the inboard seatback pivot bolt.
- (6) Install the side shield trim cover.
- (7) Install head restraint, if equipped.

REMOVAL AND INSTALLATION (Continued)

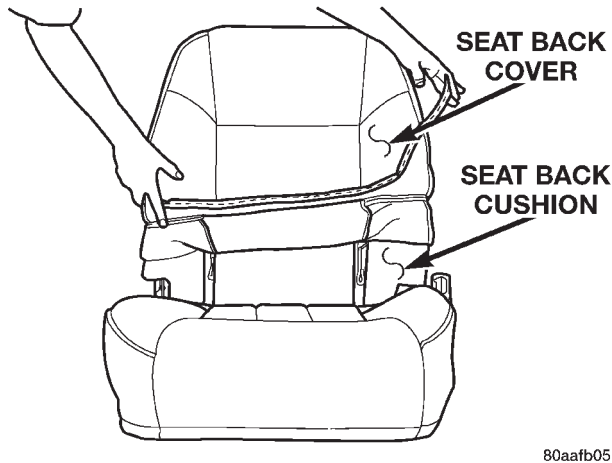

80aafb05

Fig. 8 Seatback Cover

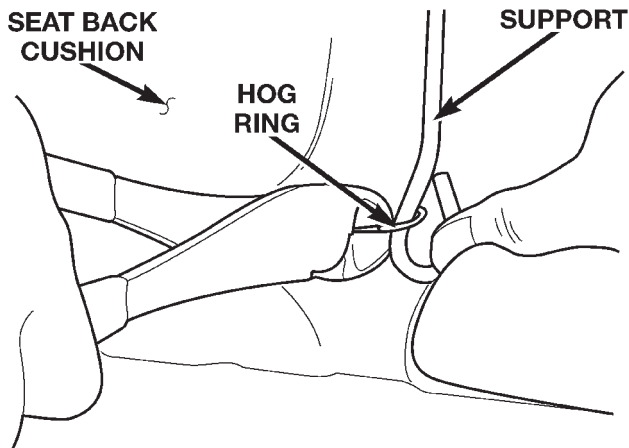

80aafb04

Fig. 9 Hog Ring

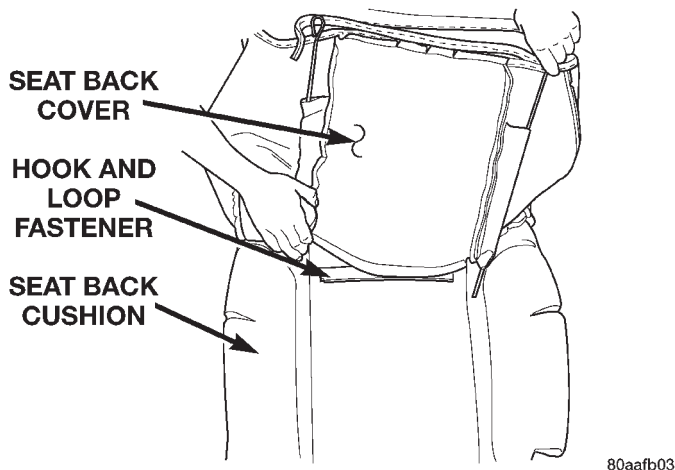

80aafb03

Fig. 10 Hook And Loop Fastener

BUCKET SEATBACK

REMOVAL

- (1) Remove side shield trim cover.
- (2) Remove inboard seatback pivot bolt.
- (3) Remove bolts attaching recliner to seat cushion frame (Fig. 11).
- (4) Separate seatback from vehicle.

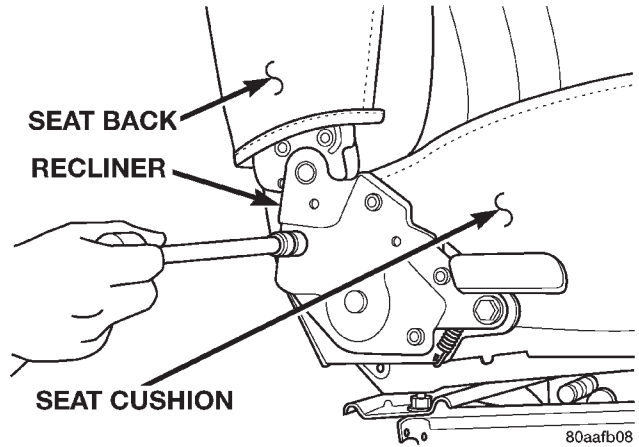

80aafb08

Fig. 11 Bucket Seatback

INSTALLATION

- (1) Position seatback on seat cushion frame.
- (2) Install inboard seatback pivot bolt.
- (3) Install bolts attaching recliner to seat cushion frame.
- (4) Install side shield trim cover.

BUCKET SEAT CUSHION COVER

REMOVAL

- (1) Remove seat from vehicle.
- (2) Remove side shield trim cover.
- (3) Remove seatback.
- (4) With the cushion side down, disengage the forward, rearward and inboard J-straps.
- (5) Disengage the clips attaching the outboard side of the cover to the cushion frame.
- (6) Turn the cushion over and roll the cover off the cushion.
- (7) Remove the hog rings attaching the cover to the cushion support wires (Fig. 12).
- (8) Separate the cover from the cushion.

INSTALLATION

- (1) Position the cover on the cushion.
- (2) Install the hog rings attaching the cover to the cushion support wires.
- (3) With the cushion side down, engage the forward, rearward and inboard J-straps.
- (4) Engage the clips attaching the outboard side of the cover to the cushion frame.

REMOVAL AND INSTALLATION (Continued)

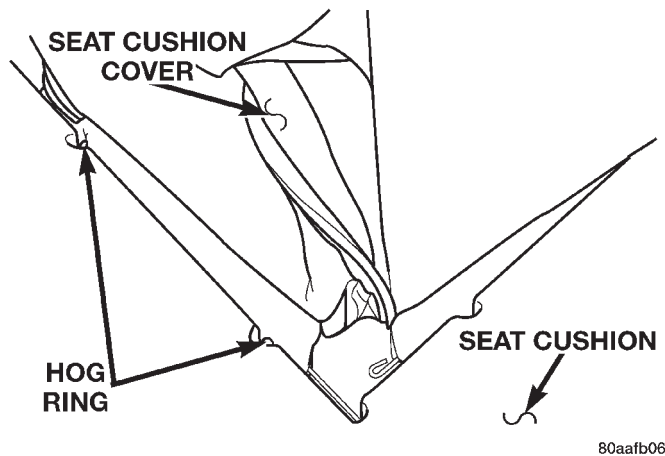

Fig. 12 Seat Cushion Cover Hog Rings

- (5) Install seatback.
- (6) Install side shield trim cover.
- (7) Install seat.

BUCKET SEAT RECLINER

REMOVAL

- (1) Remove side shield trim cover.
- (2) Disengage seatback cover zipper.
- (3) Roll outer seatback cover upward.
- (4) Remove bolts attaching recliner to seatback and seat cushion frames (Fig. 13).
- (5) Separate recliner from seat.

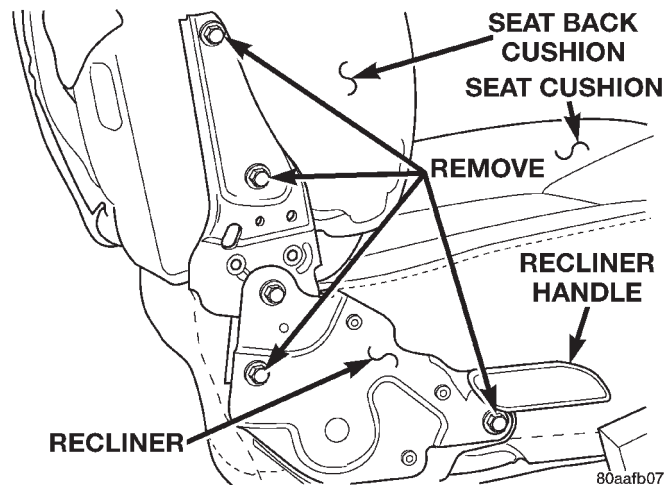

Fig. 13 Bucket Seat Recliner

INSTALLATION

- (1) Position recliner on seat.
- (2) Install bolts attaching recliner to seatback and seat cushion frames (Fig. 13).
- (3) Roll seatback cover downward.
- (4) Engage seatback cover zipper.
- (5) Install side shield trim cover.

REAR SEAT CUSHION

REMOVAL

- (1) Disengage seat cushion at rear by pulling upward on release strap (Fig. 14).
- (2) Tilt seat cushion forward.
- (3) Disengage seat cushion latch with right side release lever. Separate right side latch and left side seat bracket from floor anchor bolts, and remove cushion from vehicle (Fig. 15).

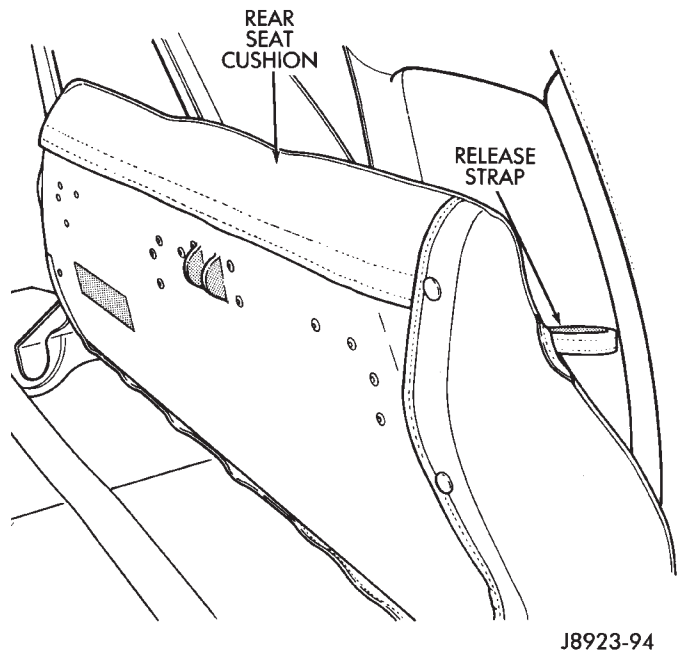

Fig. 14 Seat Cushion Release Strap

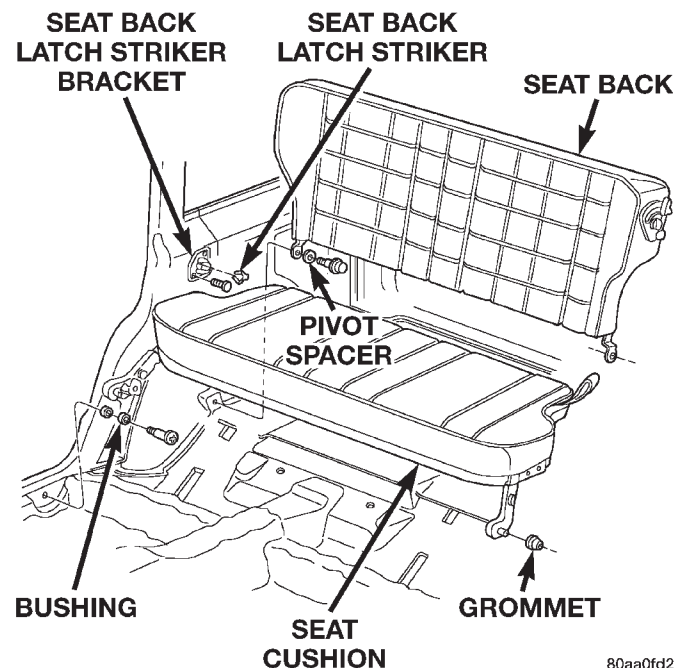

Fig. 15 Rear Seat Cushion/Seat Back

REMOVAL AND INSTALLATION (Continued)

INSTALLATION

- (1) Position seat cushion in vehicle.
- (2) Insert left pivot in anchor grommet.
- (3) Force right side latch onto anchor bolt and pivot seat cushion to horizontal position.
- (4) Lock seat cushion in-place by pressing firmly on center of cushion until latch engages.

REAR SEATBACK**REMOVAL**

- (1) Disengage the seat cushion at the rear by pulling upward on the release strap.
- (2) Tilt the seat cushion forward.
- (3) Remove the shoulder/lap belt buckles from the elastic straps.
- (4) Release the seatback latch from the striker.
- (5) Remove the pivot bolts and the washers from the wheelhouse panel anchors (Fig. 15).
- (6) Tilt the seatback forward, lift it upward and remove it from the vehicle.

INSTALLATION

- (1) Position the seatback in the vehicle.
- (2) Install the pivot bolts and the washer. Tighten the bolts with 33 N·m (25 ft. lbs.) torque.
- (3) Engage the seatback latch with the striker.
- (4) Insert the shoulder/lap belt buckles in the elastic straps.
- (5) Pivot the seat cushion to the horizontal position and lock it in-place by pressing firmly on the center of the cushion until the latch engages.

REAR SEAT CUSHION COVER**REMOVAL**

- (1) Remove the seat cushion from the vehicle.
- (2) Remove the cover side, front and rear retaining clips from the wire retainers with an appropriate removal tool (Fig. 16).
- (3) Remove the serrated retainers from the front ends of the cover with a trim panel removal tool (Fig. 17).
- (4) Remove the seat cover from the cushion.

INSTALLATION

- (1) Position the replacement cover on the cushion.
- (2) Compress the cover and attach the retaining clips to the front and rear wire retainers.
- (3) Install the serrated retainers at the ends of the cover.
- (4) Install the seat cushion in the vehicle. If necessary, refer to the installation procedure.

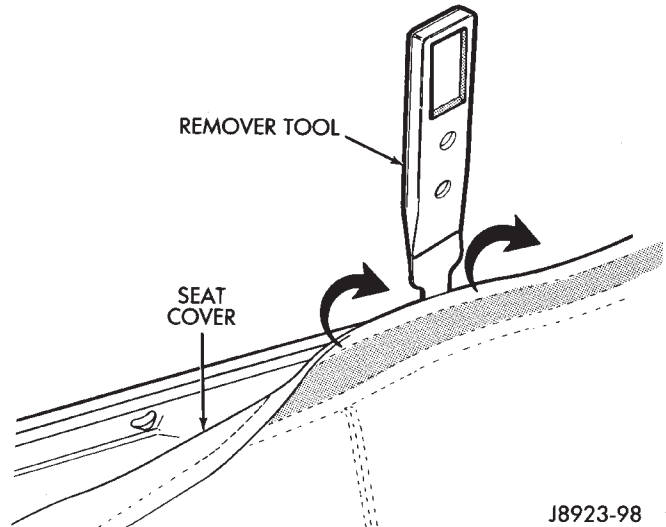

Fig. 16 Seat Cushion Cover Retaining Clip Removal

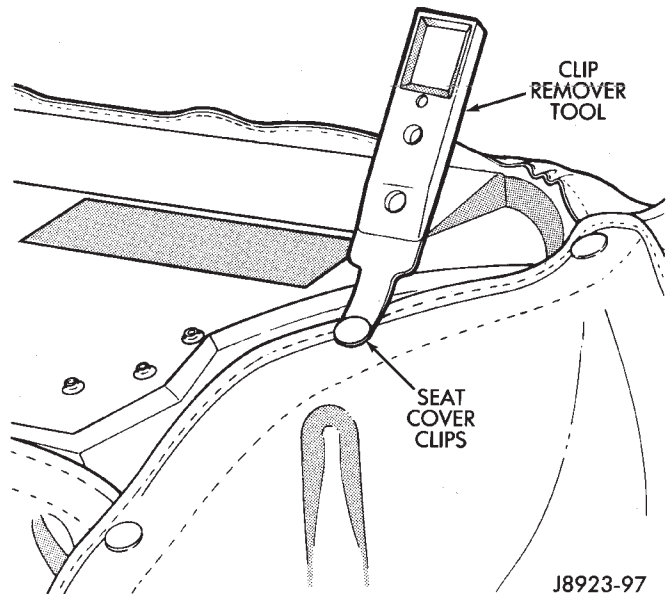

Fig. 17 Seat Cushion Cover Retaining Clip Removal

REAR SEATBACK LATCH STRIKER AND BUMPER**REMOVAL**

- (1) Disengage seat cushion at the rear by pulling upward on the release strap.
- (2) Tilt seat cushion forward.
- (3) Release seatback latch from striker.
- (4) Tilt seatback forward for access to striker bracket.
- (5) Remove screws (Fig. 18) attaching latch striker bracket and shims to trim panel.

INSTALLATION

- (1) Position shims and latch striker bracket on trim panel.

REMOVAL AND INSTALLATION (Continued)

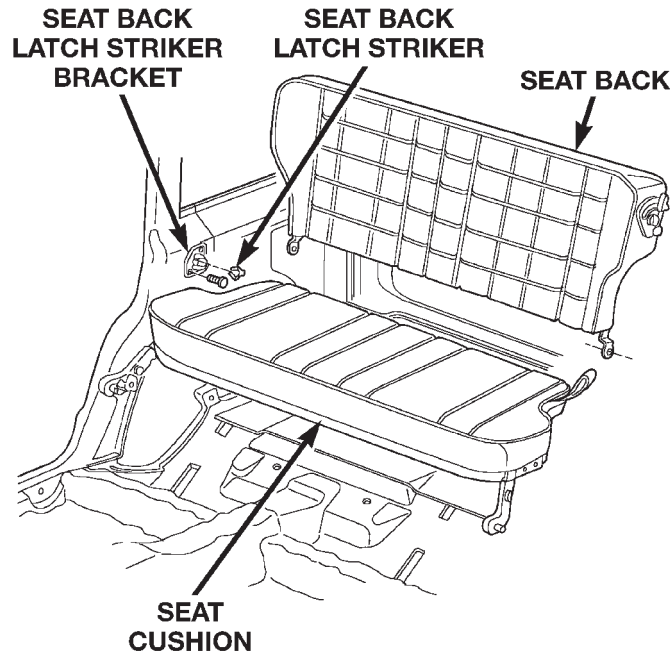

80b89834

Fig. 18 Seatback Latch Striker Bracket

(2) Install screws attaching latch striker bracket and shims to trim panel. Tighten screws to 6 N-m (50 in. lbs.) torque.

(3) Engage seatback latch with striker.

(4) Pivot seat cushion to horizontal position and lock it in-place by pressing firmly on center of the cushion until latch engages.

REAR SEATBACK COVER**REMOVAL**

- (1) Remove the seatback from the vehicle.
- (2) Remove the seatback latch release handle and bezel from the seatback.
- (3) Disengage the cover zippers.
- (4) Disengage the J-strap attaching the cover to the seat back frame (Fig. 19).
- (5) Remove the cover from the seatback pad.

INSTALLATION

- (1) Install the cover on the seatback.
- (2) Attach the cover J-strap to the seatback frame.

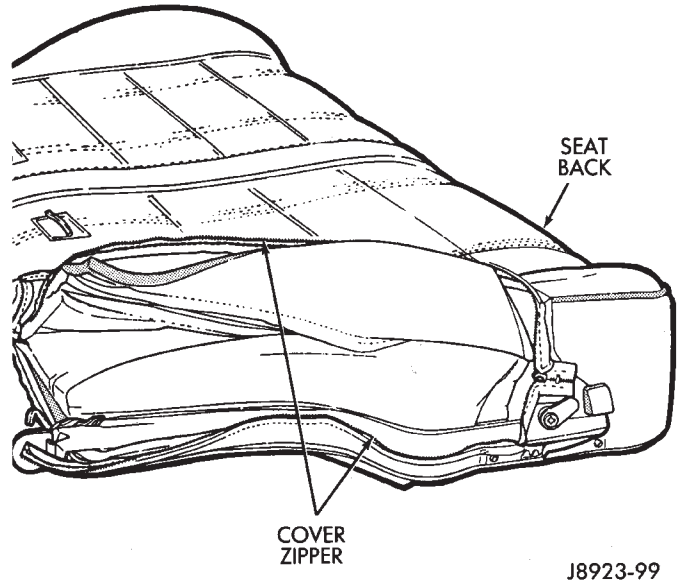

J8923-99

Fig. 19 Seatback Cover Removal

- (3) Engage the cover zippers.
- (4) Install the seat latch release bezel and handle.
- (5) Install the seatback in the vehicle.

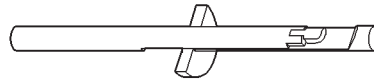
SPECIAL TOOLS**SEATS****Extractor Head Restraint Sleeve 6773**

BODY COMPONENT SERVICE

INDEX

	page		page
DIAGNOSIS AND TESTING		HEADLINER	52
WATER LEAKS	18	HOOD	20
WIND NOISE	19	HOOD HINGE	20
SERVICE PROCEDURES		HOOD LATCH	22
BODY LUBRICATION	19	HOOD LATCH STRIKER	22
REMOVAL AND INSTALLATION		HOOD RELEASE CABLE	22
A-PILLAR TRIM	44	HOOD SAFETY LATCH	23
AIR EXHAUST GRILLE	43	HOOD SILENCER PAD	23
ASSIST HANDLE	45	LEFT FRONT FENDER	27
B-PILLAR TRIM	45	LIFTGATE	54
BODY DECALS	24	LIFTGATE HINGE	54
BODY SIDE MOLDING	42	LIFTGATE LATCH	55
C-PILLAR TRIM	45	LIFTGATE LATCH STRIKER	56
COWL GRILLE	24	LIFTGATE LOCK CYLINDER	55
COWL WEATHERSTRIP	24	LIFTGATE OPENING UPPER TRIM	47
DOOR SILL SCUFF PLATE	45	LIFTGATE OUTSIDE HANDLE	55
DRIP RAIL MOLDING	42	LIFTGATE PILLAR TRIM	47
EXTERIOR NAMEPLATES	25	LIFTGATE SCUFF PLATE	48
FRONT CARPET/MAT	50	LIFTGATE SUPPORT ROD BALL STUD	55
FRONT DOOR	30	LIFTGATE SUPPORT ROD CYLINDER	54
FRONT DOOR GLASS	35	LIFTGATE TRIM PANEL	53
FRONT DOOR GLASS EXTERIOR MOLDING	34	LIFTGATE WEATHERSTRIP	56
FRONT DOOR GLASS RUN CHANNEL WEATHERSTRIP	33	LOWER A-PILLAR COWL TRIM	44
FRONT DOOR HINGE	30	LUGGAGE RACK	43
FRONT DOOR INNER BELT WEATHERSTRIP	32	QUARTER PANEL TRIM AND WHEELHOUSE COVER	46
FRONT DOOR INSIDE HANDLE ACTUATOR	32	QUARTER PANEL TRIM EXTENSION	46
FRONT DOOR LATCH	31	QUARTER WINDOW APPLIQUE	42
FRONT DOOR LATCH STRIKER	32	REAR CARPET/MAT	50
FRONT DOOR LOCK CYLINDER	31	REAR DOOR	37
FRONT DOOR OPENING SECONDARY WEATHERSTRIP	33	REAR DOOR GLASS EXTERIOR MOLDING	40
FRONT DOOR OPENING WEATHERSTRIP	33	REAR DOOR GLASS RUN CHANNEL WEATHERSTRIP	39
FRONT DOOR OUTER BELT WEATHERSTRIP	32	REAR DOOR HINGE	38
FRONT DOOR OUTSIDE HANDLE	31	REAR DOOR INNER BELT WEATHERSTRIP	39
FRONT DOOR RESTRAINT	30	REAR DOOR INSIDE HANDLE ACTUATOR	39
FRONT DOOR SPACER BLOCKS—TWO-DOOR VEHICLES	34	REAR DOOR LATCH	38
FRONT DOOR TRIM PANEL	28	REAR DOOR LATCH STRIKER	39
FRONT DOOR WATERDAM	29	REAR DOOR OUTER BELT WEATHERSTRIP	39
FRONT DOOR WINDOW REGULATOR	34	REAR DOOR OUTSIDE HANDLE	38
FRONT FENDER FLARE	26	REAR DOOR RESTRAINT	37
FRONT INNER SCUFF PLATE	45	REAR DOOR TRIM PANEL	36
FRONT SHOULDER BELT/BUCKLE	48	REAR DOOR WATERDAM	37
FRONT WHEELHOUSE LINER	27	REAR DOOR WEATHERSTRIP	40
FULL FLOOR CONSOLE	50	REAR DOOR WINDOW GLASS	41
GRILLE	20	REAR DOOR WINDOW REGULATOR	40
GRILLE OPENING PANEL (GOP)	20	REAR FENDER FLARE	42
		REAR SHOULDER/LAP BELT/BUCKLE	49

REARVIEW MIRROR	51
REARVIEW MIRROR SUPPORT BRACKET	51
RIGHT FRONT FENDER	27
SAFETY LATCH STRIKER	23
SIDE VIEW MIRROR	26
SUNVISORS	52
ADJUSTMENTS	
DOOR	57
DOOR LATCH ADJUSTMENT	57
HOOD	57
LIFTGATE	58

REAR SEATBACK	58
SPECIFICATIONS	
BODY GAP AND FLUSH MEASUREMENTS ...	117
BODY LUBRICANTS	58
BODY OPENING DIMENSIONS	118
BODY SEALING LOCATIONS	102
STRUCTURAL ADHESIVE LOCATIONS	114
TORQUE SPECIFICATIONS	125
WELD LOCATIONS	59
SPECIAL TOOLS	
BODY	126

DIAGNOSIS AND TESTING

WATER LEAKS

Water leaks can be caused by poor sealing, improper body component alignment, body seam porosity, missing plugs, or blocked drain holes. Centrifugal and gravitational force can cause water to drip from a location away from the actual leak point, making leak detection difficult. All body sealing points should be water tight in normal wet-driving conditions. Water flowing downward from the front of the vehicle should not enter the passenger or luggage compartment. Moving sealing surfaces will not always seal water tight under all conditions. At times, side glass or door seals will allow water to enter the passenger compartment during high pressure washing or hard driving rain (severe) conditions. Overcompensating on door or glass adjustments to stop a water leak that occurs under severe conditions can cause premature seal wear and excessive closing or latching effort. After completing a repair, water-test vehicle to verify leak has stopped before returning vehicle to use.

VISUAL INSPECTION BEFORE WATER LEAK TESTS

Verify that floor and body plugs are in place, body drains are clear, and body components are properly aligned and sealed. If component alignment or sealing is necessary, refer to the appropriate section of this group for proper procedures.

WATER LEAK TESTS

WARNING: DO NOT USE ELECTRIC SHOP LIGHTS OR TOOLS IN WATER TEST AREA. PERSONAL INJURY CAN RESULT.

When the conditions causing a water leak have been determined, simulate the conditions as closely as possible.

- If a leak occurs with the vehicle parked in a steady light rain, flood the leak area with an open-ended garden hose.

- If a leak occurs while driving at highway speeds in a steady rain, test the leak area with a reasonable velocity stream or fan spray of water. Direct the spray in a direction comparable to actual conditions.

- If a leak occurs when the vehicle is parked on an incline, hoist the end or side of the vehicle to simulate this condition. This method can be used when the leak occurs when the vehicle accelerates, stops or turns. If the leak occurs on acceleration, hoist the front of the vehicle. If the leak occurs when braking, hoist the back of the vehicle. If the leak occurs on left turns, hoist the left side of the vehicle. If the leak occurs on right turns, hoist the right side of the vehicle. For hoisting recommendations refer to Group 0, Lubrication and Maintenance, General Information section.

WATER LEAK DETECTION

To detect a water leak point-of-entry, do a water test and watch for water tracks or droplets forming on the inside of the vehicle. If necessary, remove interior trim covers or panels to gain visual access to the leak area. If the hose cannot be positioned without being held, have someone help do the water test.

Some water leaks must be tested for a considerable length of time to become apparent. When a leak appears, find the highest point of the water track or drop. The highest point usually will show the point of entry. After leak point has been found, repair the leak and water test to verify that the leak has stopped.

Locating the entry point of water that is leaking into a cavity between panels can be difficult. The trapped water may splash or run from the cavity, often at a distance from the entry point. Most water leaks of this type become apparent after accelerating, stopping, turning, or when on an incline.

MIRROR INSPECTION METHOD

When a leak point area is visually obstructed, use a suitable mirror to gain visual access. A mirror can also be used to deflect light to a limited-access area to assist in locating a leak point.

DIAGNOSIS AND TESTING (Continued)

BRIGHT LIGHT LEAK TEST METHOD

Some water leaks in the luggage compartment can be detected without water testing. Position the vehicle in a brightly lit area. From inside the darkened luggage compartment inspect around seals and body seams. If necessary, have a helper direct a drop light over the suspected leak areas around the luggage compartment. If light is visible through a normally sealed location, water could enter through the opening.

PRESSURIZED LEAK TEST METHOD

When a water leak into the passenger compartment cannot be detected by water testing, pressurize the passenger compartment and soap test exterior of the vehicle. To pressurize the passenger compartment, close all doors and windows, start engine, and set heater control to high blower in HEAT position. If engine can not be started, connect a charger to the battery to ensure adequate voltage to the blower. With interior pressurized, apply dish detergent solution to suspected leak area on the exterior of the vehicle. Apply detergent solution with spray device or soft bristle brush. If soap bubbles occur at a body seam, joint, seal or gasket, the leak entry point could be at that location.

WIND NOISE

Wind noise is the result of most air leaks. Air leaks can be caused by poor sealing, improper body component alignment, body seam porosity, or missing plugs in the engine compartment or door hinge pillar areas. All body sealing points should be airtight in normal driving conditions. Moving sealing surfaces will not always seal airtight under all conditions. At times, side glass or door seals will allow wind noise to be noticed in the passenger compartment during high cross winds. Over compensating on door or glass adjustments to stop wind noise that occurs under severe conditions can cause premature seal wear and excessive closing or latching effort. After a repair procedure has been performed, test vehicle to verify noise has stopped before returning vehicle to use.

Wind noise can also be caused by improperly fitted exterior moldings or body ornamentation. Loose moldings can flutter, creating a buzzing or chattering noise. An open cavity or protruding edge can create a whistling or howling noise. Inspect the exterior of the vehicle to verify that these conditions do not exist.

VISUAL INSPECTION BEFORE TESTS

Verify that floor and body plugs are in place and body components are aligned and sealed. If component alignment or sealing is necessary, refer to the appropriate section of this group for proper procedures.

ROAD TESTING WIND NOISE

(1) Drive the vehicle to verify the general location of the wind noise.

(2) Apply 50 mm (2 in.) masking tape in 150 mm (6 in.) lengths along weatherstrips, weld seams or moldings. After each length is applied, drive the vehicle. If noise goes away after a piece of tape is applied, remove tape, locate, and repair defect.

POSSIBLE CAUSE OF WIND NOISE

- Moldings standing away from body surface can catch wind and whistle.
- Gaps in sealed areas behind overhanging body flanges can cause wind-rushing sounds.
- Misaligned movable components.
- Missing or improperly installed plugs in pillars.
- Weld burn through holes.

SERVICE PROCEDURES

BODY LUBRICATION

All mechanisms and linkages should be lubricated when necessary. This will maintain ease of operation and provide protection against rust and excessive wear. The weatherstrip seals should be lubricated to prolong their life as well as to improve door sealing.

All applicable exterior and interior vehicle operating mechanisms should be inspected and cleaned. Pivot/sliding contact areas on the mechanisms should then be lubricated.

(1) When necessary, lubricate the operating mechanisms with the specified lubricants.

(2) Apply silicone lubricant to a cloth and wipe it on door seals to avoid over-spray that can soil passenger's clothing.

(3) Before applying lubricant, the component should be wiped clean. After lubrication, any excess lubricant should be removed.

(4) The hood latch, latch release mechanism, latch striker, and safety latch should be lubricated periodically.

(5) The door lock cylinders should be lubricated twice each year (preferably autumn and spring):

- Spray a small amount of lock cylinder lubricant directly into the lock cylinder.
- Apply a small amount to the key and insert it into the lock cylinder.
- Rotate it to the locked position and then back to the unlocked position several times.
- Remove the key. Wipe the lubricant from it with a clean cloth to avoid soiling of clothing.

REMOVAL AND INSTALLATION

GRILLE

REMOVAL

- (1) Remove the headlamp/park lamp bezels.
- (2) Remove the screws attaching the grille to the grille opening panel (GOP) (Fig. 1).
- (3) Separate the grille from the GOP.

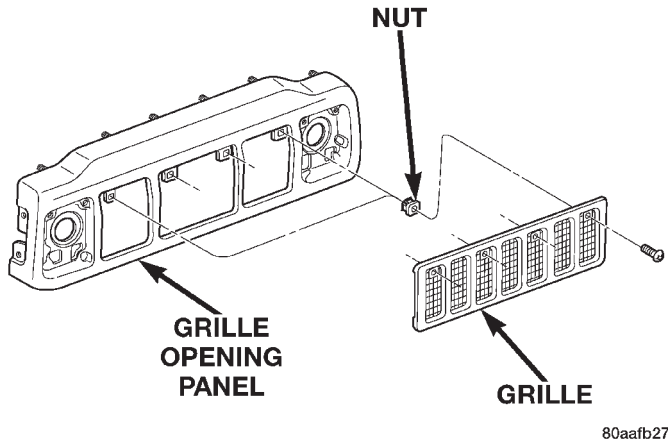

Fig. 1 Grille

INSTALLATION

- (1) Position the grille in the GOP.
- (2) Install the screws.
- (3) Install the headlamp/park lamp bezels.

GRILLE OPENING PANEL (GOP)

REMOVAL

- (1) Remove headlamp bezels.
- (2) Remove grille.
- (3) Remove side marker lamps.
- (4) Remove headlamps and park/turn signal lamps.
- (5) Open hood.
- (6) Remove nuts that attach GOP to front fenders (Fig. 2).
- (7) Remove nuts attaching GOP to support bracket.
- (8) Pull GOP forward and disconnect harness clips and front lamp harness connectors.
- (9) Remove GOP from vehicle.

INSTALLATION

- (1) Place GOP on bumper and secure all harness clips.
- (2) Connect all lamp wire harness connectors.
- (3) Position GOP on vehicle.
- (4) Install nuts attaching GOP to front fenders. Tighten nuts to 4 N·m (38 in-lbs) torque.

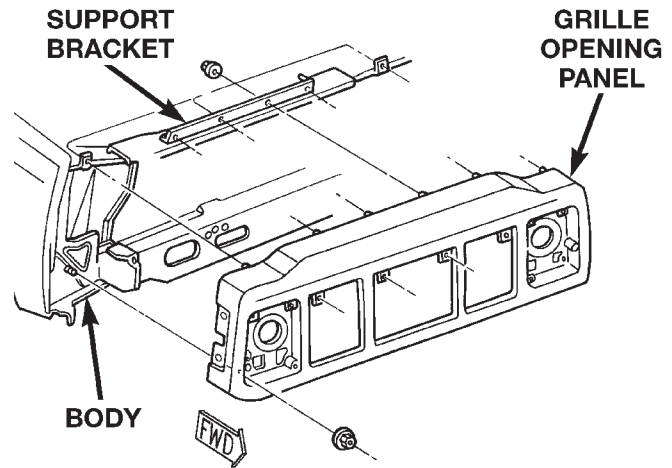

Fig. 2 Grille Opening Panel

- (5) Install nuts attaching GOP to support bracket. Tighten nuts to 4 N·m (38 in-lbs) torque.
- (6) Install headlamps and park/turn signal lamps.
- (7) Install grille.
- (8) Install side marker lamps.
- (9) Install headlamp bezels.
- (10) Adjust headlamp aim, if necessary.

HOOD

REMOVAL

- (1) Raise hood.
- (2) Disconnect underhood lamp wire harness connector, if equipped.
- (3) Disconnect release cable from latch release bellcrank.
- (4) Remove latch release cable clips and remove cable from hood (Fig. 3).
- (5) Mark location of hood, hinges and hinge shims for installation.
- (6) Remove bolts that attach hinges to hood.
- (7) Remove hood from vehicle with aid of a helper.

INSTALLATION

- (1) Position hood on shims and hinges; finger-tighten hinge bolts.
- (2) Align hinges and shims with reference marks and tighten hinge bolts.
- (3) Connect latch release cable and latch connecting rod to bellcrank.
- (4) Attach latch release cable to clips.
- (5) Connect underhood lamp wire harness connector.

HOOD HINGE

REMOVAL

- (1) Raise and support hood.

REMOVAL AND INSTALLATION (Continued)

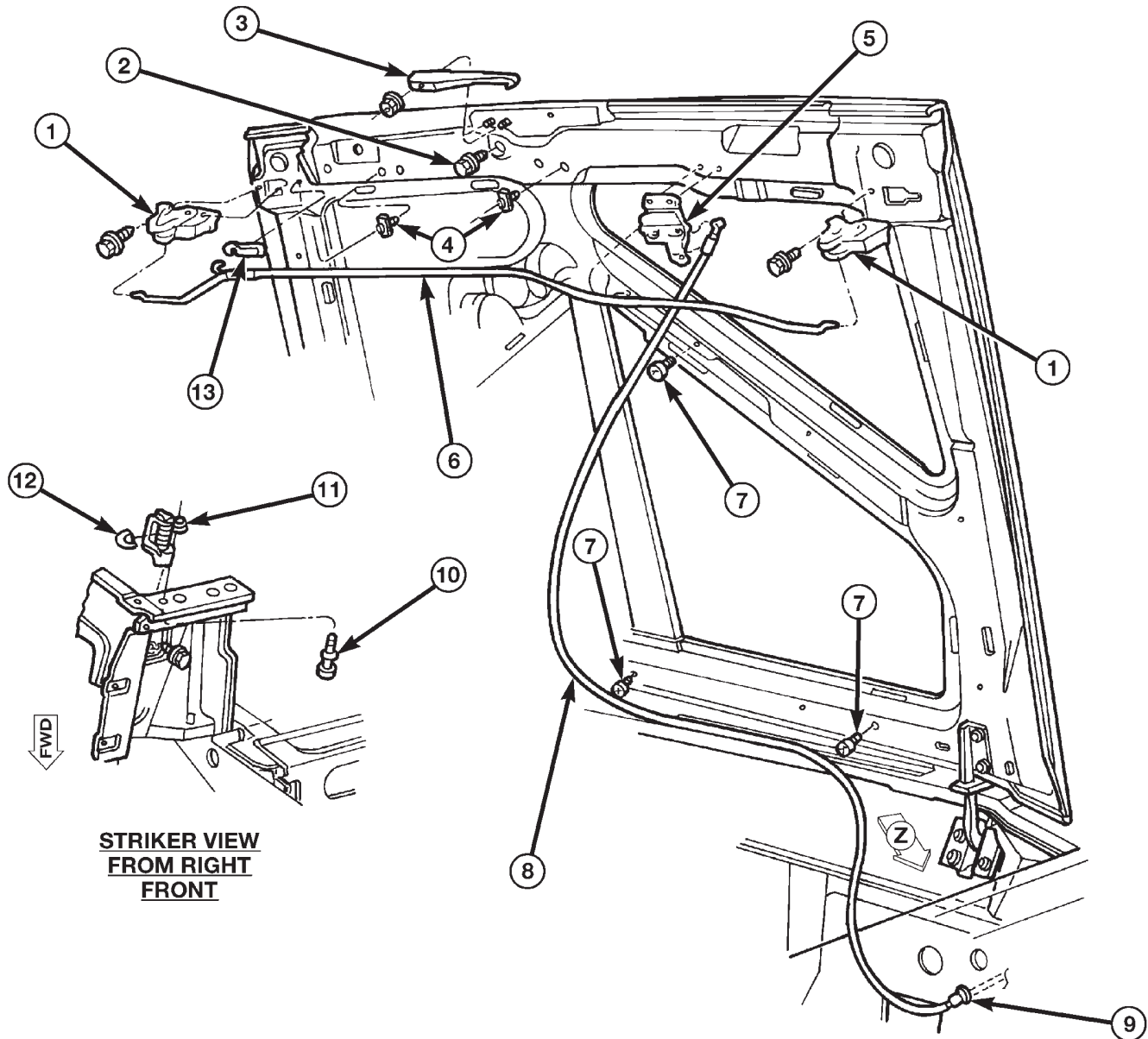

**STRIKER VIEW
FROM RIGHT
FRONT**

- 1. LATCH
- 2. BUMPER
- 3. CATCH
- 4. CLIP
- 5. BELLCRANK
- 6. ROD
- 7. CLIP
- 8. CABLE
- 9. GROMMET
- 10. SHOULDER BOLT
- 11. STRIKER
- 12. SHIM
- 13. SPRING

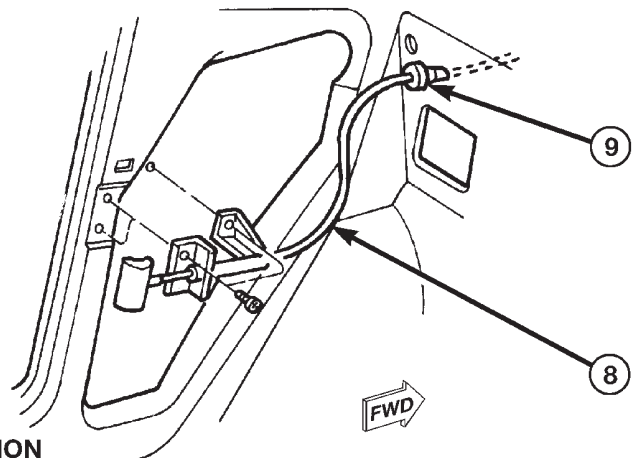

**VIEW IN DIRECTION
OF ARROW Z**

Fig. 3 Hood Components

REMOVAL AND INSTALLATION (Continued)

- (2) Using a grease pencil or equivalent, mark position of hood.
- (3) Remove seal from hinge base (Fig. 4).
- (4) Remove hinge retaining nuts from studs.

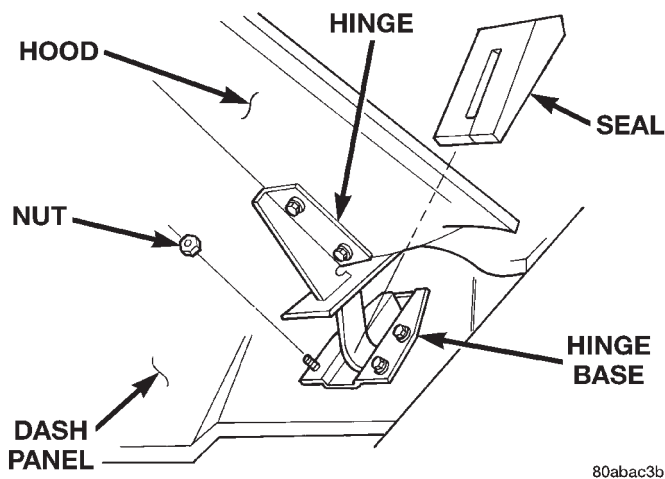

Fig. 4 Hood Hinge and Seal

INSTALLATION

- (1) Position hinge over studs and align with reference marks.
- (2) Install nuts.

NOTE: If a replacement hinge seal is being installed, position it around hinge arm, force it against hinge base.

- (3) Position hinge seal around hinge arm and on hinge base.
- (4) Adjust hood as necessary.

HOOD LATCH

REMOVAL

- (1) Remove the screw that attaches the latch to the hood inner panel (Fig. 5).
- (2) Disconnect the latch connecting rod.
- (3) Remove the latch from the hood.

INSTALLATION

- (1) Connect the latch to the latch connecting rod and
- (2) Position the latch on the hood inner panel.
- (3) Install the screw that attaches the latch to the hood inner panel.

HOOD LATCH STRIKER

REMOVAL

- (1) Remove headlamp bezel.
- (2) Remove parklamp.
- (3) Release the spring attaching the headlamp mounting bucket to the grille opening panel (GOP).

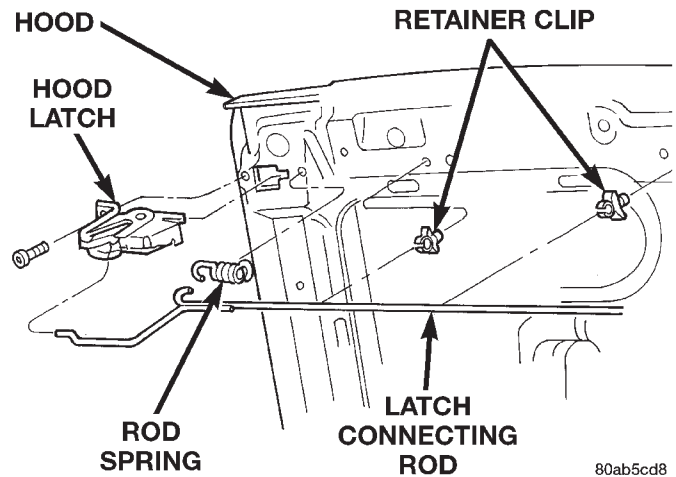

Fig. 5 Hood Latch

- (4) Remove the headlamp with mounting bucket attached from the adjusting screws.
- (5) Remove the upper bolt attaching the striker to the top of the (GOP).
- (6) Remove the lower bolt attaching the striker to the (GOP).
- (7) Remove the striker and shims.

INSTALLATION

- (1) Position the shims and striker on the (GOP) and install the bolts.
- (2) Install the headlamp and mounting bucket.
- (3) Install parklamp.
- (4) Install the headlamp bezel.
- (5) Test the striker/hood alignment by opening and closing the hood several times. Adjust the striker, if necessary.

HOOD RELEASE CABLE

REMOVAL

- (1) Drill out bellcrank to hood rivet heads and remove rivets (Fig. 6).
- (2) Disconnect bellcrank from latch rod and hood release cable. Remove bellcrank from hood.
- (3) Disconnect hood release cable from clips on hood.
- (4) Remove left cowl side trim panel.
- (5) Remove cable bracket screws from cowl side panel.
- (6) Route cable through dash panel and remove it from under instrument panel.

INSTALLATION

- (1) Insert replacement cable end through hole in dash panel into engine compartment.
- (2) Route cable forward and seat grommet in dash panel.

REMOVAL AND INSTALLATION (Continued)

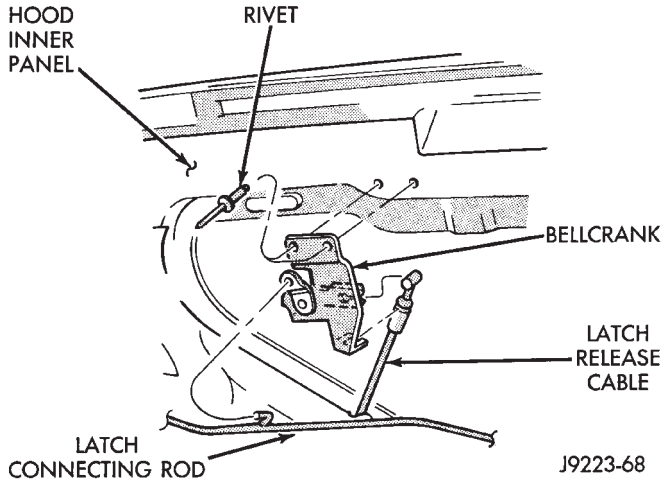

Fig. 6 Hood Release Cable Bellcrank

- (3) Position cable bracket on cowl side panel and install screws.
- (4) Install left cowl side trim panel.
- (5) Connect cable and latch rod to bellcrank.
- (6) Position bellcrank on hood and install rivets.
- (7) Attach cable to clips.
- (8) Test release cable for proper operation.

HOOD SAFETY LATCH

REMOVAL

- (1) Open and support hood.
- (2) Remove the nuts attaching the safety latch to the inner hood panel (Fig. 7).
- (3) Separate the safety latch from the hood.

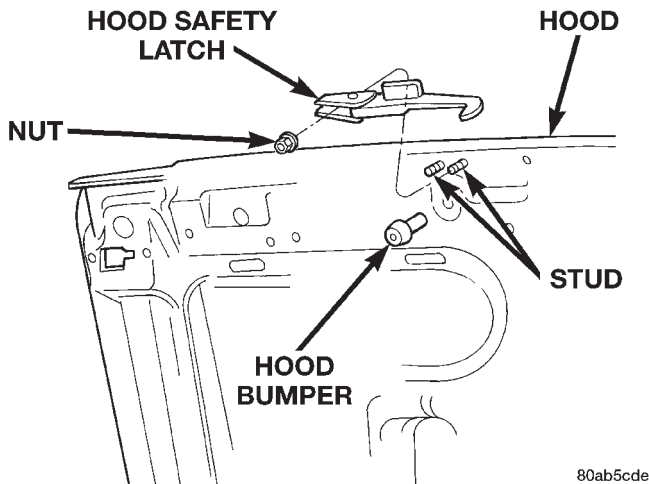

Fig. 7 Hood Safety Latch

INSTALLATION

- (1) Position the safety latch on the hood.
- (2) Install the nuts attaching the safety latch to the inner hood panel.
- (3) Close hood.

SAFETY LATCH STRIKER

REMOVAL

- (1) Remove striker screws from radiator support crossmember (Fig. 8).
- (2) Remove striker from crossmember.

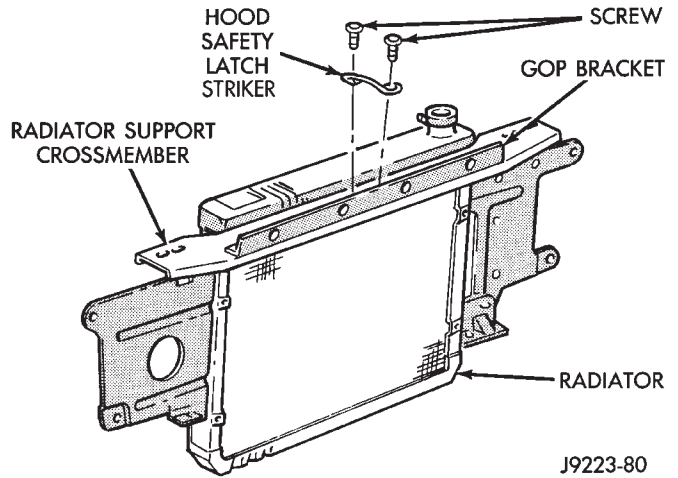

Fig. 8 Hood Safety Latch Striker

INSTALLATION

- (1) Position striker on radiator support crossmember and install screws.
- (2) Test safety latch operation.

HOOD SILENCER PAD

REMOVAL

- (1) Open and support hood.
- (2) Remove the hood latch release bellcrank.
- (3) Remove the clips attaching the latch connecting rod to the hood inner panel.
- (4) Remove the retainers attaching the hood silencer pad to the inner hood panel (Fig. 9).
- (5) Separate the hood silencer pad from the hood.

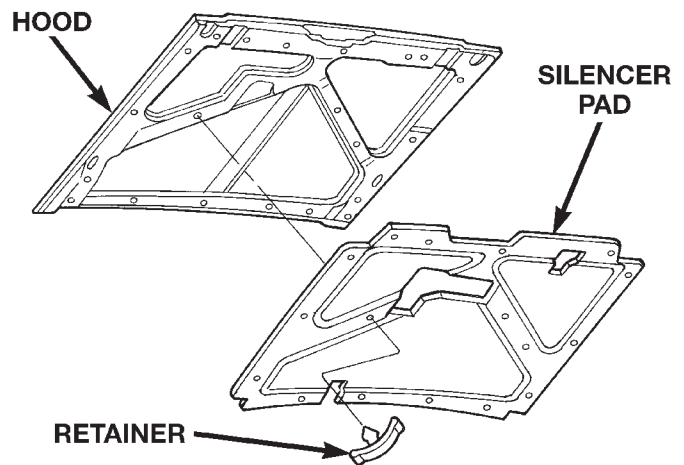

Fig. 9 Hood Silencer Pad

REMOVAL AND INSTALLATION (Continued)

INSTALLATION

- (1) Position the hood silencer pad on the hood inner panel.
- (2) Install the retainers attaching the hood silencer pad to the inner hood panel.
- (3) Install the clips attaching the latch connecting rod to the hood inner panel.
- (4) Install the hood latch release bellcrank.
- (5) Close hood.

COWL WEATHERSTRIP

REMOVAL

The cowl weatherstrip is attached to the cowl with adhesive tape.

- (1) Peel weatherstrip from cowl (Fig. 10).

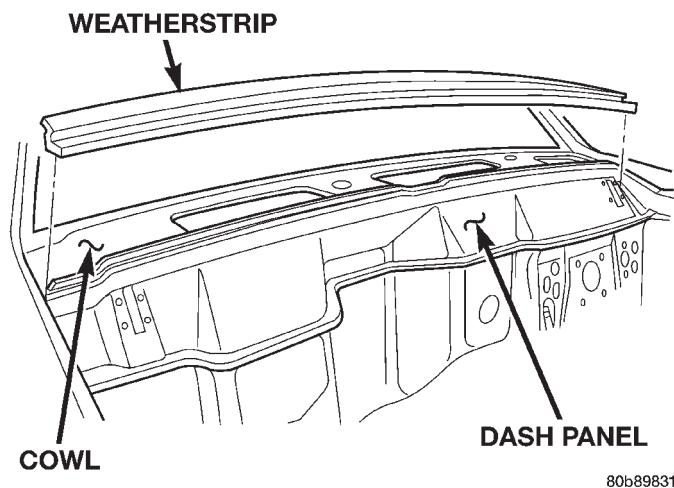

Fig. 10 Cowl Weatherstrip

INSTALLATION

- (1) Clean contact surface with Mopar Super Kleen or equivalent.
- (2) Position weatherstrip on cowl.
- (3) Press weatherstrip into place.

COWL GRILLE

REMOVAL

- (1) Remove the windshield wiper arms from the pivots.
- (2) Remove the screws that attach the grille to the cowl.
- (3) Remove the windshield washer tubes from the nozzles.
- (4) Remove the cowl grille and screen from the cowl (Fig. 11).

INSTALLATION

CAUTION: The washer fluid tubes must be routed and installed so that they are not pinched.

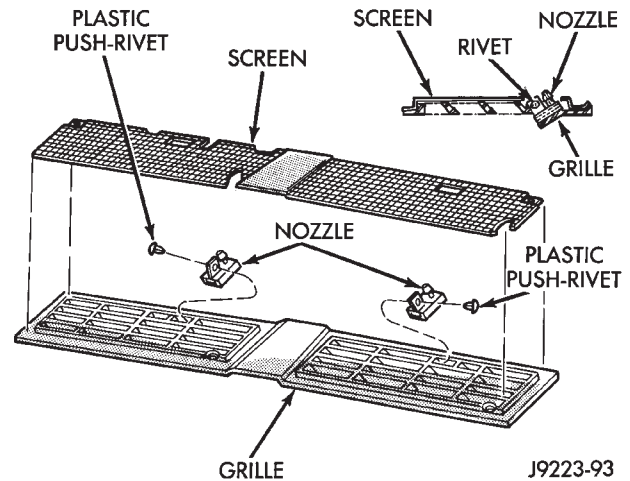

Fig. 11 Cowl Grille, Screen & Washer Nozzles

- (1) Position the cowl grille and screen on the cowl.
- (2) Install the windshield washer tubes on the nozzles.
- (3) Install the cowl screen and grille screws with new sealer. Tighten in sequence (Fig. 12).

NOTE: Force the cowl grille rearward while tightening the screws.

- (4) Install the windshield wiper arms on the pivots.

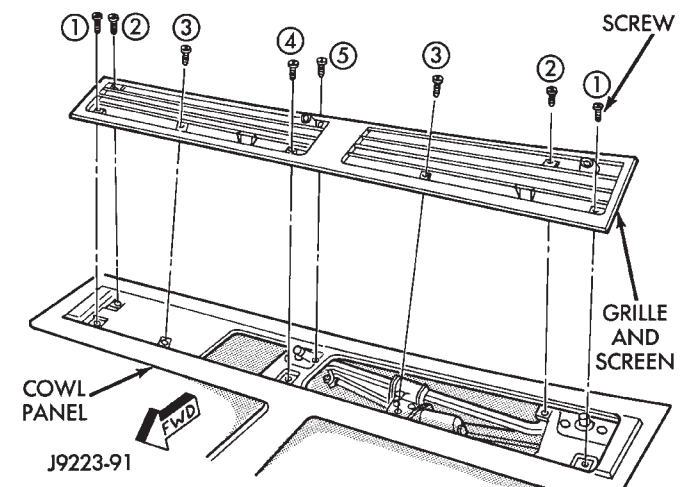

Fig. 12 Cowl Grille Screw Tightening Sequence

BODY DECALS

Small nicks, scratches and other surface marks in a decal can be touched-up with paint.

To eliminate blisters and air bubbles in a decal, pierce them with a needle or pin.

A heat gun can also be used to remove small wrinkles in a decal.

Decal replacement requires that the metal repair and paint refinish be completed first.

REMOVAL AND INSTALLATION (Continued)

The work area temperature should be between 21°C (70°F) and 32°C (90°F). **A decal should not be replaced if the work area temperature is less than 21°C (70°F).**

The following equipment and material are necessary for removal and installation:

- Liquid dish detergent (for the wetting solution).
- Mixture of wetting solution.
- Commercial wax and silicone removal solution.
- Isopropyl (rubbing) alcohol.
- Small squeegee (plastic or hard rubber).
- Water bucket and sponge.
- Clean wiping rags or paper towels.
- Heat gun (or infra-red heat bulb).
- Wax pencil.
- Sharp knife, single edge razor blade or X-acto knife.
- Pair of scissors.
- Needle or pin.

WARNING: USE DECAL REMOVAL SOLUTION IN A WELL-VENTILATED AREA ONLY.

A decal removal solution can be used for removal at areas where a heat gun is ineffective. Follow the manufacturers instructions whenever this type of product is used.

REMOVAL

- (1) Clean the repaired surface as necessary.
- (2) Start at one end of the decal and apply heat with a heat gun. Slowly peel the decal from the panel by pulling it back. **Do not pull the decal outward from panel.**

INSTALLATION

- (1) The area that will be covered by the decal must be cleaned with cleaning solution.
- (2) Freshly painted surfaces must be thoroughly dry.
- (3) Clean the painted surface with a commercial wax and silicone removal solution. Wipe the surface with a clean cloth and allow it to dry.
- (4) Prepare a wetting solution by mixing two or three teaspoons of dish detergent with 1 gallon of water. Do not use soap.

NOTE: Too much detergent will reduce the effectiveness of the mixture.

- (5) Use a clean sponge and apply the wetting solution to the adhesive side of the decal and to the painted panel surface. The wetting solution will permit ease of decal movement when positioning it.
- (6) Align a straight edge with the existing decal ends (Fig. 13).

NOTE: If applicable, the body panel character line can be used as the decal alignment reference.

(7) Position the decal and carrier on the body panel (Fig. 14) and the mark length with a wax pencil.

(8) Position the decal and carrier on the body panel and hold it in-place with masking tape.

(9) Lift the bottom edge of decal and carrier. Use the tape sections as hinges, and reverse the position of decal and carrier.

CAUTION: Always remove the carrier from the decal, never remove the decal from carrier

(10) Bend a corner of carrier outward and then, with a flick of the finger, separate the corner of carrier from the decal.

(11) Return the decal back to its original position. If a solution is being used, position adhesive side of the decal on panel. Apply the solution to the outside of the decal.

(12) Hold the decal against the panel surface while separating the carrier from the decal.

(13) If applicable, remove the cover from face of decal.

(14) Using a squeegee smooth out the decal to remove wrinkles and/or air bubbles.

(15) Inspect the decal with reflected light to find any damage. Remove all the air and/or moisture bubbles.

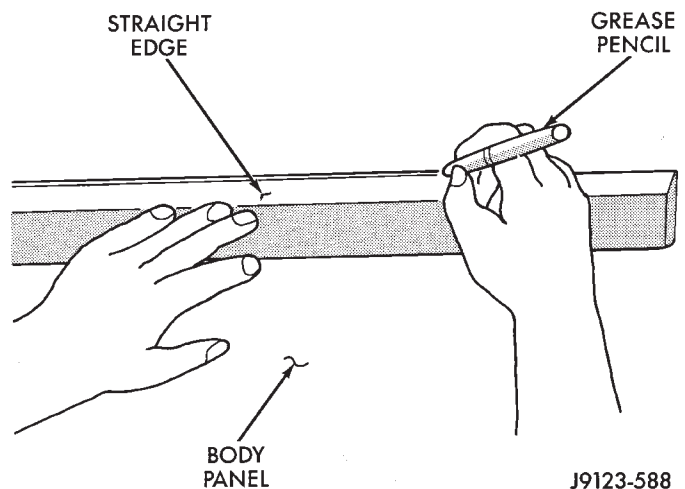

J9123-588

Fig. 13 Decal Alignment Reference Mark

EXTERIOR NAMEPLATES

REMOVAL

NOTE: Exterior nameplates are attached to body panels with adhesive tape.

REMOVAL AND INSTALLATION (Continued)

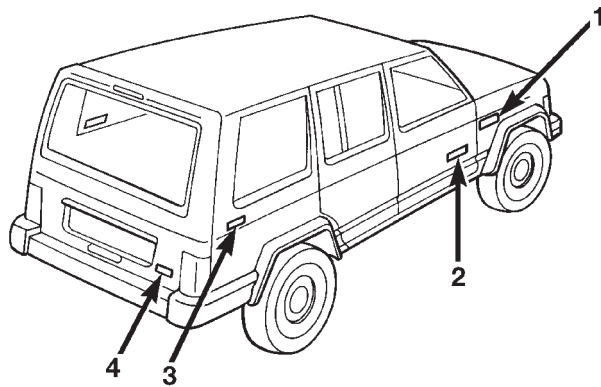

1 = SPORT 3 = 4 X 4
2 = CHEROKEE COUNTRY 4 = 4.0L

80b8982c

Fig. 14 Body Decals

(1) Apply a length of masking tape on the body, parallel to the top edge of the nameplate to use as a guide, if necessary.

(2) If temperature is below 21°C (70°F) warm emblem with a heat lamp or gun. Do not exceed 52°C (120°F) when heating emblem.

(3) Insert a plastic trim stick or a hard wood wedge behind the emblem to separate the adhesive backing from the body.

(4) Clean adhesive residue from body with MOPAR Super Clean solvent or equivalent.

INSTALLATION

(1) Remove protective cover from adhesive tape on back of emblem.

(2) Position emblem properly on body (Fig. 15).

(3) Press emblem firmly to body with palm of hand.

(4) If temperature is below 21°C (70°F) warm emblem with a heat lamp or gun to assure adhesion. Do not exceed 52°C (120°F) when heating emblem.

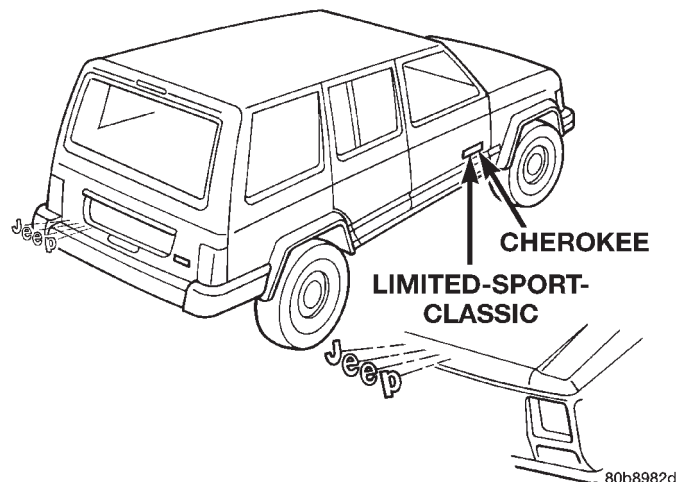

80b8982d

Fig. 15 Exterior Nameplates

SIDE VIEW MIRROR

REMOVAL

(1) Remove the door trim panel.

(2) Remove the screw attaching the mirror trim cover/speaker grille to the door inner panel.

(3) remove push-in fastener attaching trim cover to door inner panel (use special tool C-4829).

(4) Disconnect the power mirror wire connector, if equipped.

(5) Remove the screws attaching the mirror to the door (Fig. 16).

(6) Separate the mirror from the door.

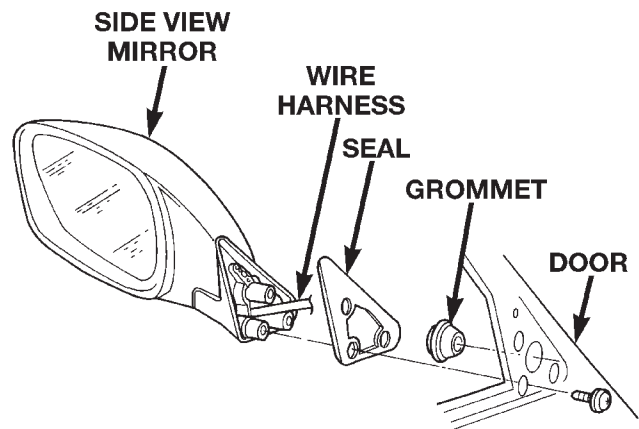

80aab5f

Fig. 16 Side View Mirror

INSTALLATION

(1) Position the mirror on the door.

(2) Install the screws attaching the mirror to the door.

(3) Connect the power mirror wire connector, if equipped.

(4) Install new push-in fastener.

(5) Install the mirror trim cover/speaker grille.

(6) Install the door trim panel.

FRONT FENDER FLARE

REMOVAL

(1) Remove the screw attaching the lower part of flare to the bottom of the fender.

(2) Remove the nuts attaching the fender flare retainer to the wheelhouse splash shield (Fig. 17).

(3) Remove the liner from the fender.

(4) Remove the fasteners attaching the fender flare and retainer to the fender.

(5) Separate the fender flare and retainer from the fender.

REMOVAL AND INSTALLATION (Continued)

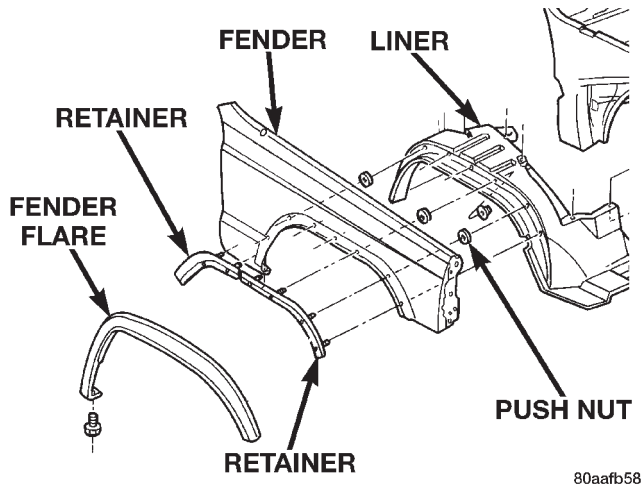

Fig. 17 Fender Flare

INSTALLATION

- (1) Position the fender flare and retainer on the fender.
- (2) Install the nuts attaching the fender flare and retainer to the wheelhouse fender.
- (3) Install the screw attaching the lower part of flare to the bottom of the fender.

FRONT WHEELHOUSE LINER

REMOVAL

- (1) Hoist vehicle.
- (2) Remove tire.
- (3) Remove the push-in fasteners attaching the wheelhouse liner to the inner fender.
- (4) Separate the wheelhouse liner from the fender (Fig. 18).

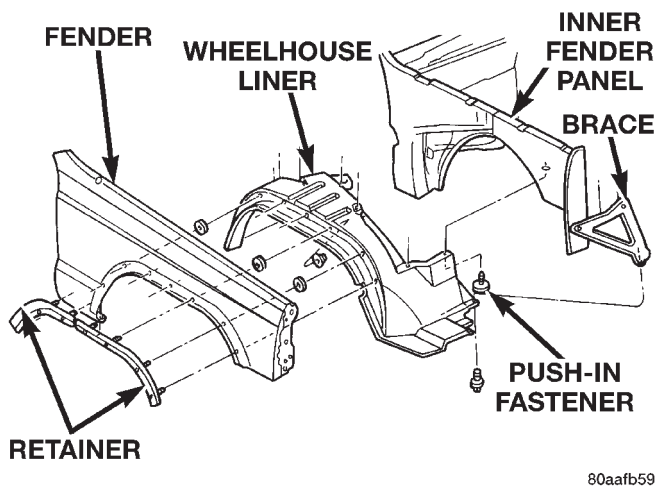

Fig. 18 Front Wheelhouse Liner

INSTALLATION

- (1) Position the wheelhouse liner in the fender.
- (2) Install new push-in fasteners attaching the wheelhouse liner to the inner fender.

- (3) Install tire.
- (4) Lower vehicle.

RIGHT FRONT FENDER

REMOVAL

- (1) Raise and support the hood.
- (2) Remove the grille opening panel (GOP).
- (3) If equipped, remove the radio antenna mast, and components from the fender.
- (4) Remove the coolant recovery bottle.
- (5) Raise and support the vehicle.
- (6) Remove the right front wheel.
- (7) Remove the front bumper end cap.
- (8) Remove the wheelhouse liner.
- (9) Remove the fender flare and retainers.
- (10) Disconnect all wire harness connectors.
- (11) Remove the air deflector.
- (12) Remove the fender lower screws (Fig. 19).
- (13) Remove the fender top, front and the rear screws.
- (14) Remove the screws attaching the fender to the inner support bracket (Fig. 20).
- (15) Separate the fender from the inner fender panel.

INSTALLATION

- (1) Position the fender on the inner fender panel.
- (2) Install all fender screws finger-tight.
- (3) Align the fender with the body panels and tighten the screws attaching the fender to the body panels.
- (4) Install the air deflector.
- (5) Install the fender flare and retainers.
- (6) Install the wheelhouse liner.
- (7) Install the front bumper end cap.
- (8) Install the wheel, remove the support and lower the vehicle.
- (9) Install the grille opening panel (GOP).
- (10) Install the radio antenna.

LEFT FRONT FENDER

REMOVAL

- (1) Raise and support the hood.
- (2) Remove the grille opening panel (GOP).
- (3) Raise and support the vehicle.
- (4) Remove the left front wheel.
- (5) Remove the front bumper end cap.
- (6) Remove the fender flare and retainers.
- (7) Remove the wheelhouse liner.
- (8) Remove the air deflector.
- (9) Remove the fender lower screws.
- (10) Remove the fender top, front and the rear screws.

REMOVAL AND INSTALLATION (Continued)

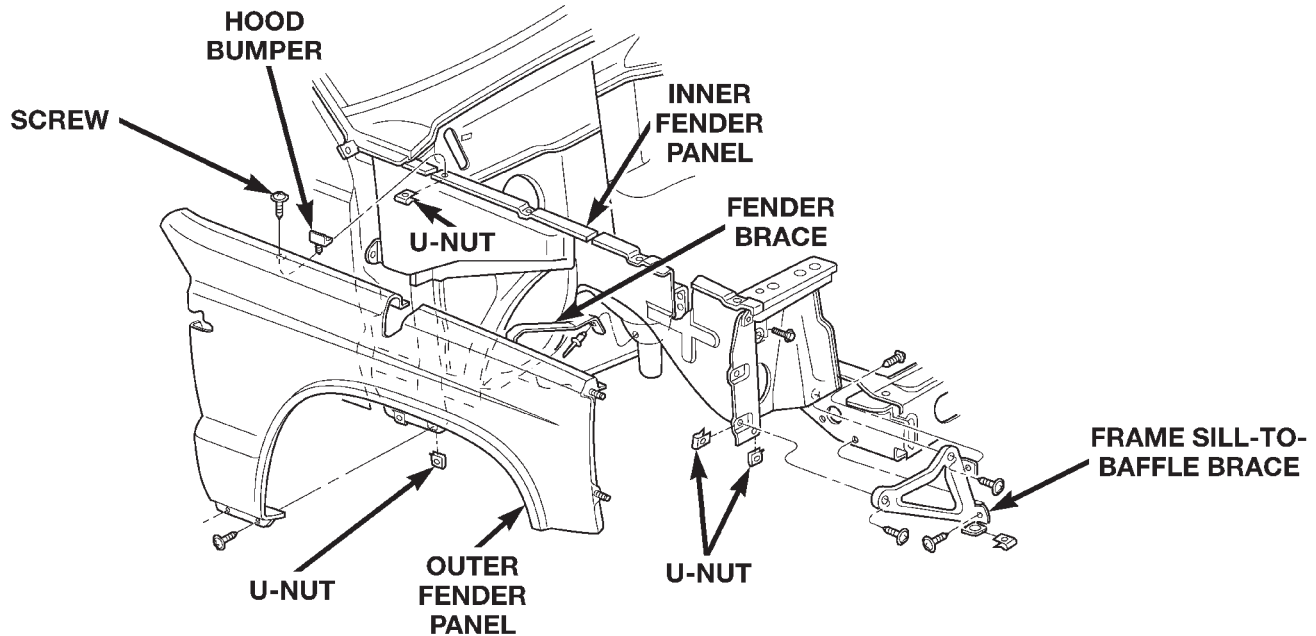

80ae8355

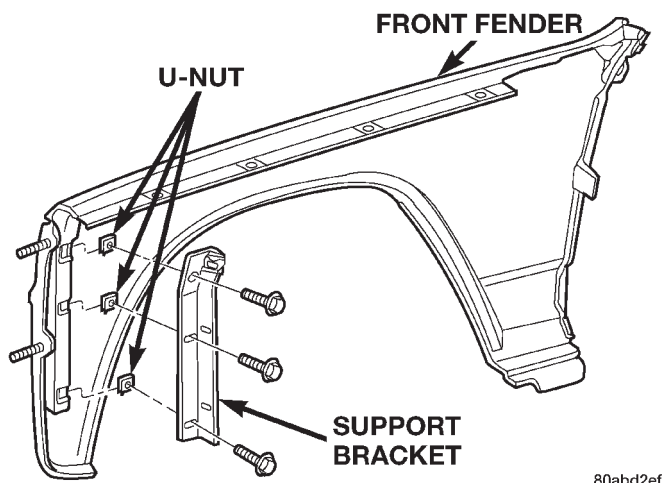
Fig. 19 Right Front Fender

80abd2ef

Fig. 20 Inner Support Bracket

(11) Remove the screws attaching the fender to the inner support bracket.

(12) Separate the fender from the inner fender panel.

INSTALLATION

- (1) Position the fender on the inner fender panel.
- (2) Install all fender screws finger-tight.
- (3) Align the fender with the body panels and tighten the screws attaching the fender to the body panels.
- (4) Install the air deflector.
- (5) Install the wheelhouse liner.
- (6) Install the fender flare and retainers.
- (7) Install the front bumper.

(8) Install the wheel, remove the support and lower the vehicle.

(9) Install the grille opening panel (GOP).

FRONT DOOR TRIM PANEL**REMOVAL**

- (1) Roll window down.
- (2) Remove window crank, if equipped (Fig. 21).
- (3) Remove the screws attaching the trim panel to the door inner panel (Fig. 22) and (Fig. 23).
- (4) Separate the trim panel fasteners from door inner panel with a pry tool (use special tool C-4829) (Fig. 24).
- (5) Lift the trim panel up and outward to separate from the inner belt seal.
- (6) Move the door trim panel outward and disconnect the handle-to-latch rods.
- (7) Disconnect the power door locks/windows/mirrors wire harness connectors, if equipped.
- (8) Remove the trim panel from door.

INSTALLATION

- (1) Replace any broken or damaged push-in fasteners.
- (2) Connect the power door locks/windows/mirrors wire harness connectors, if equipped.
- (3) Move the door trim panel outward and connect the handle-to-latch rods.
- (4) Position the trim panel on the inner belt seal and push down to seat.
- (5) Align the locating pins and push- (Fig. 25) in fasteners. Press inward to secure.

REMOVAL AND INSTALLATION (Continued)

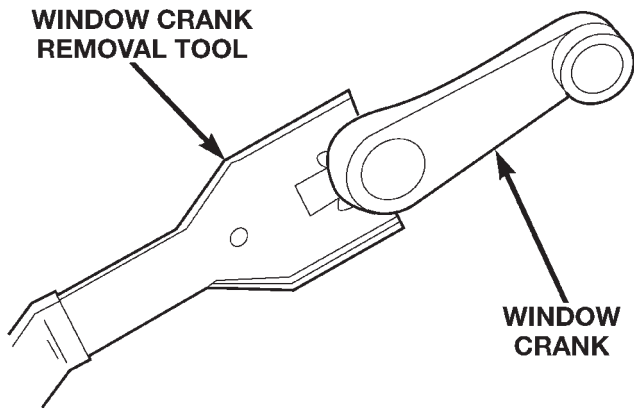

80ad2f28

Fig. 21 Window Crank—Typical

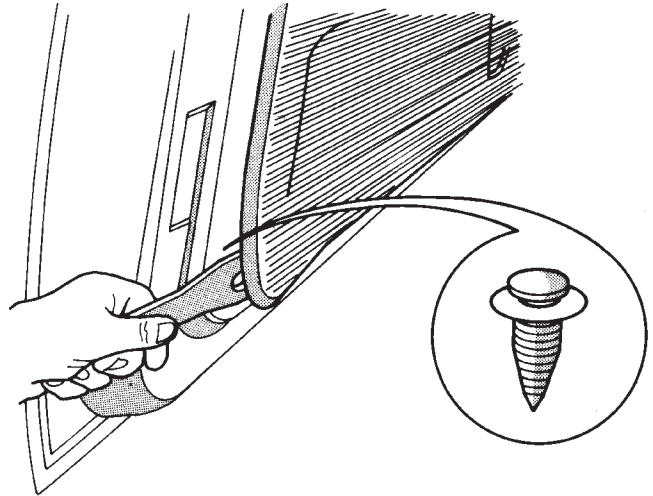

Fig. 24 Detaching Trim Panel Push-In Fasteners

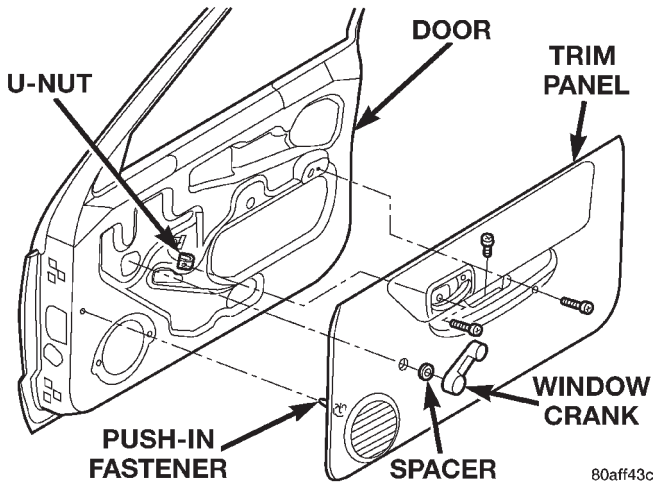

Fig. 22 Front Door Trim Panel-Manual Window

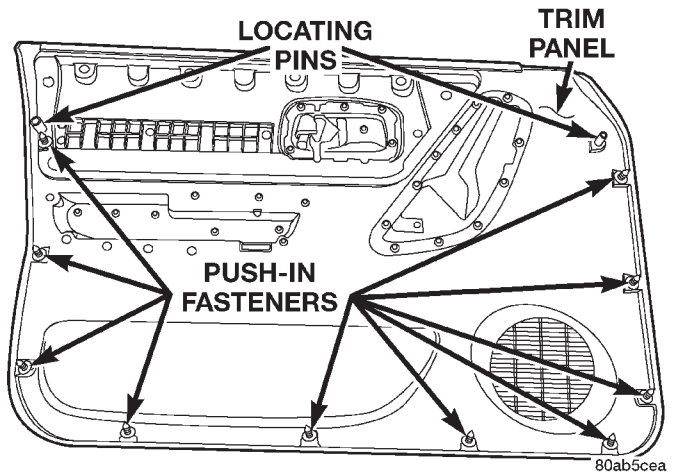

Fig. 25 Push-In Fasteners

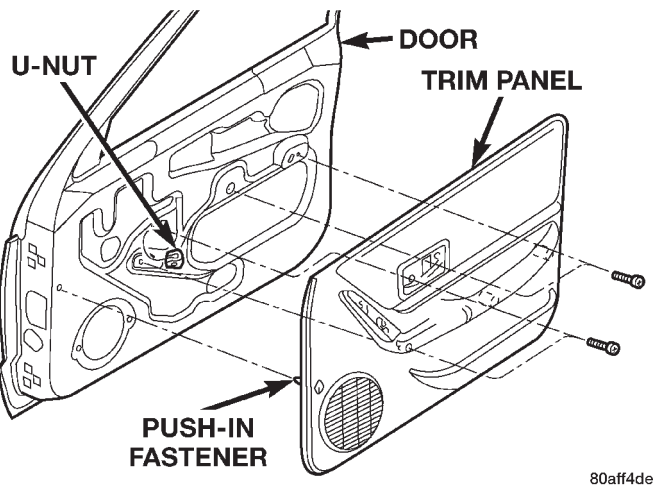

Fig. 23 Front Door Trim Panel-Power Window

(6) Install the screws attaching the trim panel to the door inner panel.

(7) Install the window crank, if equipped.

FRONT DOOR WATERDAM

REMOVAL

The waterdam is attached to the door inner panel with a butly adhesive. If cohesive separation of the butly between the waterdam and door inner panel occurs during the removal process, cut the strands of butly with a razor knife or equivalent.

- (1) Remove door trim panel.
- (2) Disengage clips attaching wire harnesses to the door inner panel.
- (3) Push the harnesses/connectors through the waterdam and into the door.
- (4) Grasp the upper and lower rearward corners of the waterdam and rapidly peel back the waterdam from the door inner panel.
- (5) Separate the waterdam from the door inner panel.

REMOVAL AND INSTALLATION (Continued)

INSTALLATION

- (1) Route the latch rods through the waterdam.
- (2) Position the waterdam on the door, apply adhesive as necessary and press into place.
- (3) Route the harnesses/connectors through the waterdam.
- (4) Engage clips attaching wire harnesses to the door inner panel.
- (5) Install door trim panel.

FRONT DOOR

REMOVAL

- (1) Remove door restraint (check) retaining pin.
- (2) For vehicles equipped with power windows, power mirrors and power door locks, remove trim panel and waterdam. Disconnect all components and route wire harness out of door.
- (3) Remove bolts that attach hinge to door. (Fig. 26).
- (4) Remove door from vehicle.

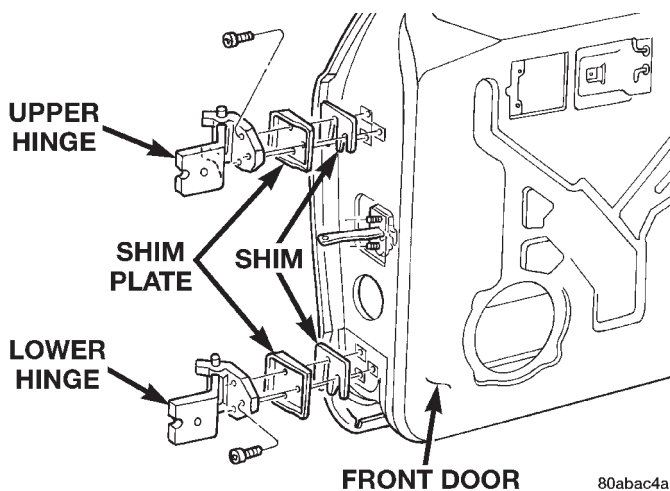

Fig. 26 Front Door Hinge

INSTALLATION

- (1) Position door in body opening.
- (2) Align door hinges, plates and shims and install bolts. Tighten bolts to 3 N·m (2 ft. lbs.) torque.
- (3) Install door restraint (check) pin.
- (4) If applicable, route and connect wire harness connectors.
- (5) Install door waterdam and trim panel.

FRONT DOOR HINGE

REMOVAL

- (1) Remove door restraint (check) retaining pin.
- (2) Remove door hinge bolts and shims (Fig. 27).
- (3) Retain door hinge shims for correct installation.

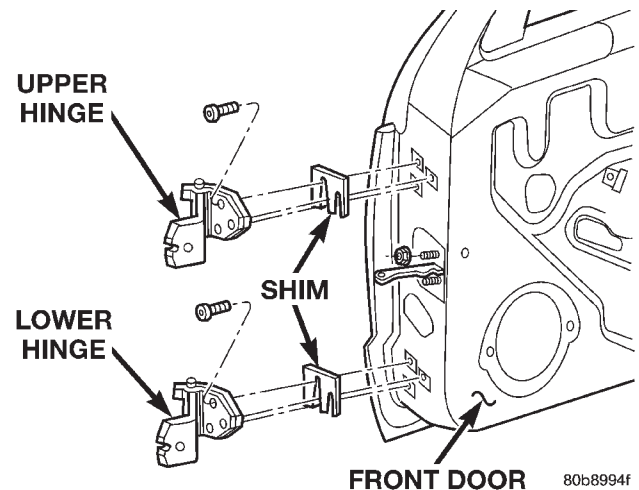

Fig. 27 Front Door Hinge

INSTALLATION

- (1) Position hinge plates and shims on door face.
- (2) Align door hinges and shims with bolt holes and install hinge bolts. Tighten bolts to 3 N·m (2 ft. lbs.) torque.
- (3) Adjust/align latch striker and latch as necessary.
- (4) Install door restraint (check) retaining pin.

FRONT DOOR RESTRAINT

REMOVAL

- (1) Remove door trim panel.
- (2) Remove door radio speaker from door inner panel.
- (3) Remove door restraint (check) retaining pin from bracket with a punch.
- (4) Remove nuts and remove restraint via speaker opening. (Fig. 28).

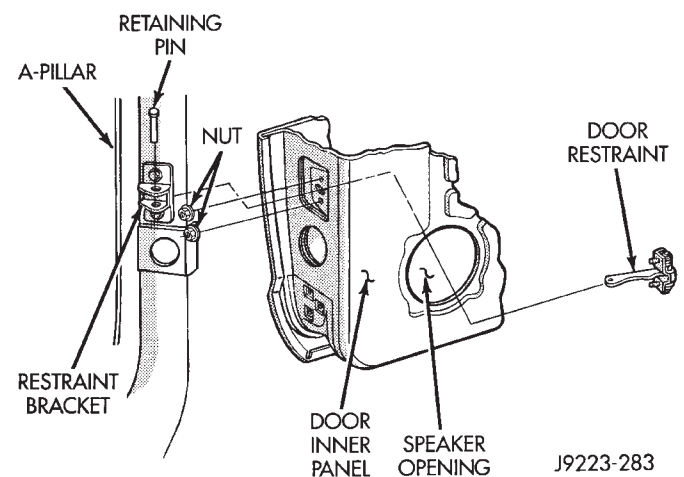

Fig. 28 Door Restraint (Check)

REMOVAL AND INSTALLATION (Continued)

INSTALLATION

(1) Position door restraint in door by way of opening and install nuts.

NOTE: Ensure the spring on the door restraint is facing outward.

(2) Position door restraint in bracket with holes aligned and insert retaining pin.

(3) Install radio speaker and door trim panel.

FRONT DOOR OUTSIDE HANDLE

REMOVAL

(1) Remove the door trim panel and waterdam.

(2) Remove the access hole cover and remove the rearward nut attaching the door handle to the door. (Fig. 29).

(3) Disconnect the handle-to-latch rod from the handle latch release lever arm.

(4) Remove the forward nut attaching the handle to the door.

(5) Separate the handle from the door.

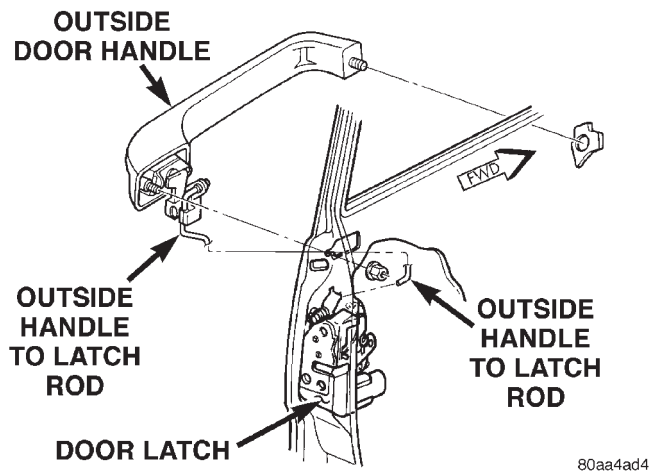

80aa4ad4

Fig. 29 Front Door Outside Handle

INSTALLATION

(1) Position the handle in the door.

(2) Install the forward nut attaching the handle to the door.

(3) Connect the latch to handle rod, to the handle latch release lever arm.

(4) Install the rearward nut attaching the door handle to the door.

(5) Install the access hole cover.

(6) Install the door waterdam and trim panel.

FRONT DOOR LOCK CYLINDER

REMOVAL

(1) Remove the door trim panel.

(2) Peel back waterdam to access lock cylinder.

(3) Disconnect the door latch-to-lock cylinder rod at the door latch (Fig. 30).

(4) Remove the lock cylinder retainer clip.

(5) Remove the lock cylinder.

(6) If applicable, remove the door latch-to-lock cylinder rod from the original lock cylinder. Connect it to the replacement lock cylinder.

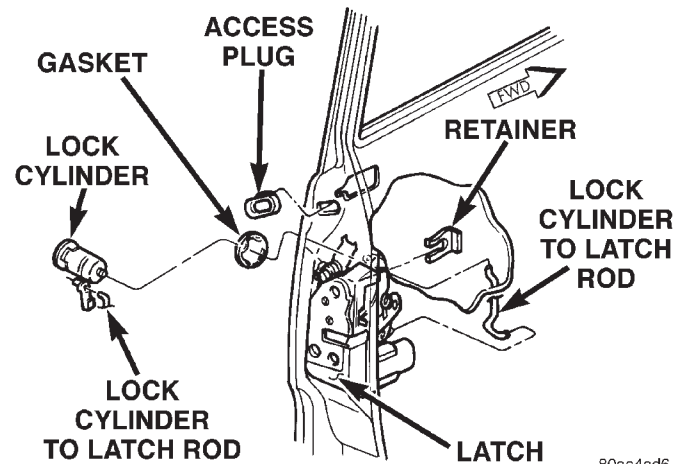

80aa4ad6

Fig. 30 Door Lock Cylinder

INSTALLATION

(1) Position the lock cylinder and in the door opening.

(2) Install the retainer clip.

(3) Connect the door latch-to-lock cylinder rod to the door latch.

(4) Press the waterdam into position.

(5) Install the door trim panel.

FRONT DOOR LATCH

REMOVAL

(1) Remove door trim panel and waterdam.

(2) Remove screws attaching latch to door.

(3) Disconnect all rods from latch (Fig. 31).

(4) Disconnect power lock motor wire connector, if equipped.

(5) Remove latch from door face.

INSTALLATION

(1) Position latch on door face.

(2) Connect power lock motor wire connector, if equipped.

(3) Connect all rods to latch.

(4) Install screws attaching latch to door. Tighten screws to 11 N·m (8 ft. lbs.) torque.

REMOVAL AND INSTALLATION (Continued)

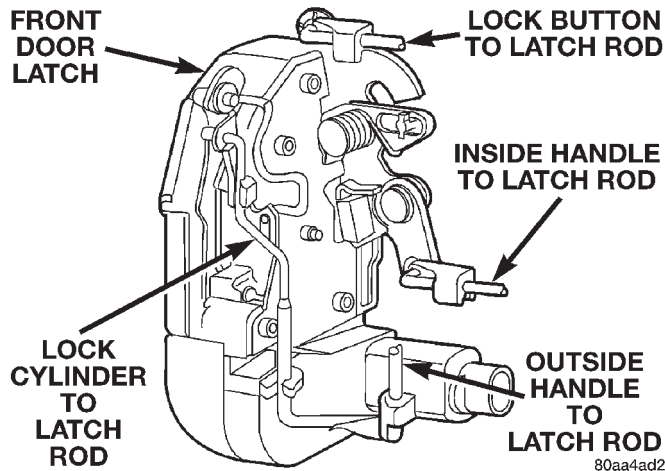

Fig. 31 Door Latch

- (5) Install waterdam and door trim panel.

FRONT DOOR LATCH STRIKER

REMOVAL

- (1) Using a grease pencil or equivalent, mark position of striker.
- (2) Remove screws attaching striker to B-pillar (Fig. 32).
- (3) Separate striker from B-pillar.

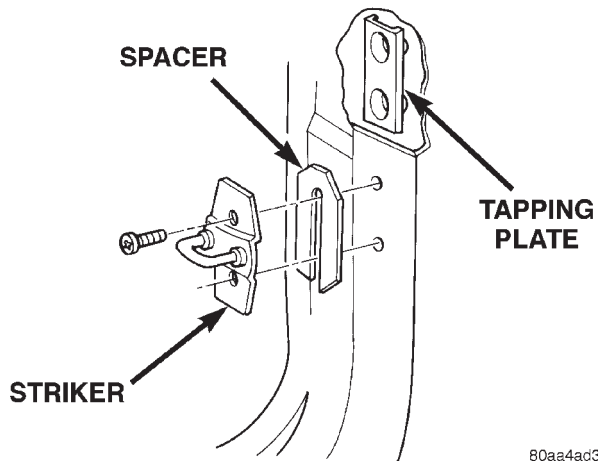

Fig. 32 Front Door Latch Striker

INSTALLATION

- (1) Position and align striker on B-pillar.
- (2) Install screws attaching striker to B-pillar. Tighten screws to 28 N·m (20 ft. lbs.) torque.

FRONT DOOR INSIDE HANDLE ACTUATOR

REMOVAL

The front door inside handle actuator is heat staked to the front door trim panel during the manufacturing process.

- (1) Remove the door trim panel.
- (2) Using an X-ACTO knife or equivalent, cut the melted tabs securing the inside handle to the door trim panel.
- (3) Separate the inside handle from the trim panel.

INSTALLATION

- (1) Position the inside handle in the trim panel.
- (2) Heat stake the inside handle to the trim panel.
- (3) Install the door trim panel.

FRONT DOOR INNER BELT WEATHERSTRIP

REMOVAL

- (1) Roll window down.
- (2) Remove door trim panel.
- (3) Pull up on the rear corner of the weatherstrip and lift from the door (Fig. 33).

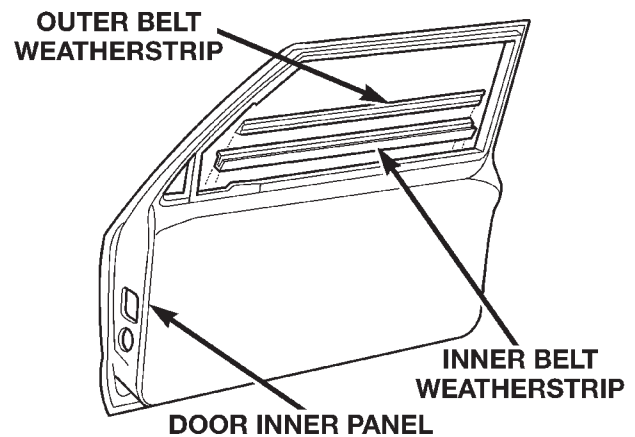

Fig. 33 Front Door Inner/Outer Belt Weatherstrip

INSTALLATION

- (1) Position the weatherstrip on the door.
- (2) Push weatherstrip down to seat onto door.
- (3) Install door trim panel.

FRONT DOOR OUTER BELT WEATHERSTRIP

REMOVAL

- (1) Roll window down.
- (2) Using a trim stick, pry up the rear outer corner of the weatherstrip.
- (3) Lift the weatherstrip up to separate from the door (Fig. 33).

INSTALLATION

- (1) Position the weatherstrip on the door.
- (2) Push weatherstrip down to seat onto door.

REMOVAL AND INSTALLATION (Continued)

FRONT DOOR GLASS RUN CHANNEL WEATHERSTRIP

REMOVAL

- (1) Remove door trim panel.
- (2) Remove waterdam.
- (3) Starting at rear corner, peel weatherstrip from around door frame.

INSTALLATION

(1) Install the weatherstrip in the following sequence:

- Press weatherstrip into upper rear corner.
- Press weatherstrip into lower front corner.
- Work/press the weatherstrip upward and to the upper front corner, seat the weatherstrip into the channel.
- Continue working/pressing the weatherstrip into the channel along the upper window frame.
- Press weatherstrip into lower rear corner.
- Work/press the weatherstrip upward and to the upper rear corner, seat the weatherstrip into the channel.
- Press the weatherstrip to seat into the front lower glass run channel.

(2) As applicable, move upward and forward evenly until the weatherstrip seal is fully seated in the channel.

- (3) Install waterdam.
- (4) Install door trim panel.

FRONT DOOR OPENING WEATHERSTRIP

REMOVAL

- (1) Remove A-pillar trim panel.
- (2) Remove B-pillar upper trim panel.
- (3) Remove cowl side trim panel.
- (4) Remove inner scuff plate.
- (5) Remove B-pillar lower trim panel.
- (6) Grasp seal and separate from door opening.

INSTALLATION

- (1) Position weatherstrip at corners.
- (2) Move upward and around edge of door opening. Seat seal on flange.
- (3) When installing a door opening weatherstrip seal, start at the door sill center line.
- (4) Move upward and around the perimeter of the door opening and seat the weatherstrip on the flange (Fig. 35).
- (5) Install cowl side trim panel.
- (6) Install inner scuff plate.
- (7) Install B-pillar lower trim panel.
- (8) Install B-pillar upper trim panel.
- (9) Install A-pillar trim panel.

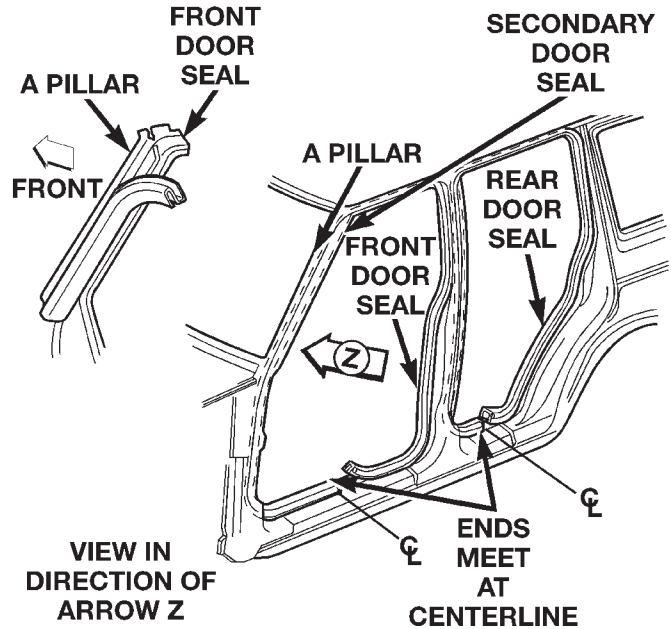

80aa0fd7

Fig. 34 Door Opening Weatherstrip

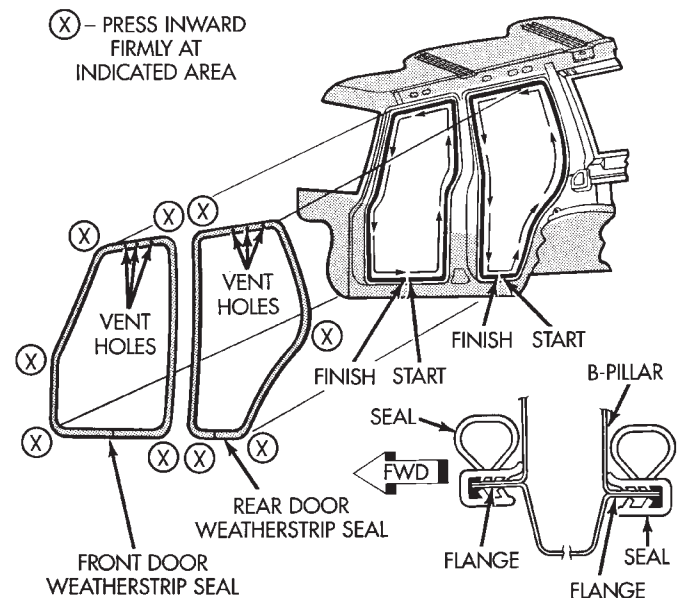

J9223-271

Fig. 35 Door Opening Weatherstrip

FRONT DOOR OPENING SECONDARY WEATHERSTRIP

REMOVAL

The front door opening secondary weatherstrip is attached to the A-pillar with adhesive tape (Fig. 34).

- (1) Using a heat gun, heat the weatherstrip and slowly peel the weatherstrip from the A-pillar

REMOVAL AND INSTALLATION (Continued)

INSTALLATION

- (1) Clean the contact surface on the A-pillar.
- (2) Remove the carrier backing and position the weatherstrip on the A-pillar. Press into place.

FRONT DOOR GLASS EXTERIOR MOLDING

REMOVAL

- (1) Open the window completely.
- (2) Remove the outer belt weatherstrip.
- (3) Pry and pull the molding sections from the door panel flange (Fig. 36).

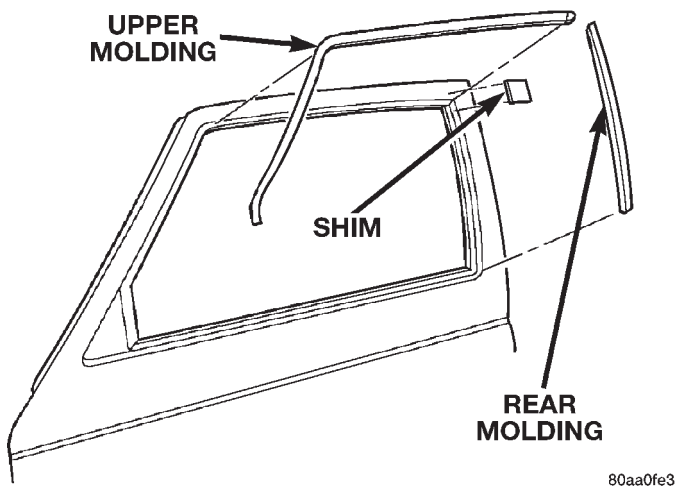

Fig. 36 Front Door Glass Exterior Molding

INSTALLATION

- (1) Start at the forward end of the upper molding, force the molding onto the door panel and continue rearward until it is completely seated on the flange.
- (2) Mate the rear molding with the upper molding and force the molding edge inward.
- (3) Continue pressing and moving downward to complete the installation.
- (4) Install the outer belt weatherstrip.

FRONT DOOR WINDOW REGULATOR

REMOVAL

- (1) Remove the door trim panel.
- (2) Remove the waterdam.
- (3) Remove the window glass.
- (4) Loosen the bolts attaching the regulator to the inner door panel (Fig. 37) and (Fig. 38) as applicable.
- (5) Lift the regulator upward to release it from the key hole slots and remove it through the access hole in the door inner panel.

INSTALLATION

- (1) Position the regulator in the door and align with key hole slots.

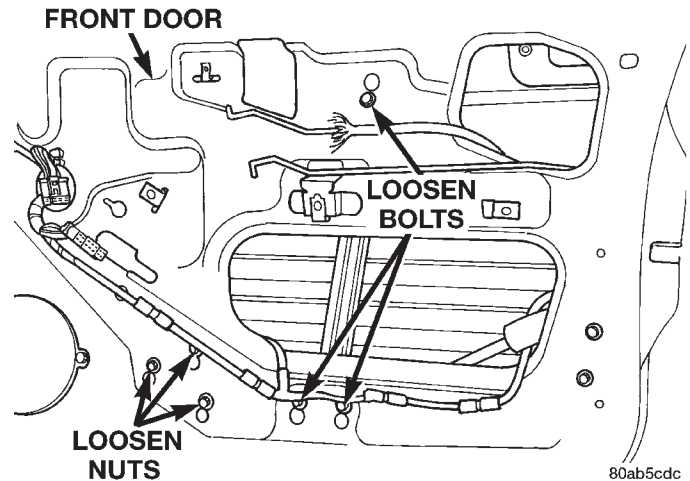

Fig. 37 Power Window Regulator

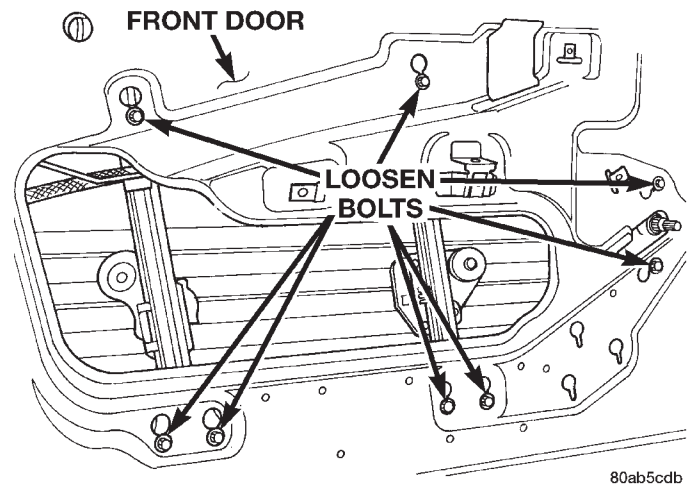

Fig. 38 Manual Window Regulator

- (2) Attach the regulator to door inner panel with bolts (Fig. 39).
- (3) Install the window glass
- (4) Install the waterdam.
- (5) Install the trim panel.

FRONT DOOR SPACER BLOCKS—TWO-DOOR VEHICLES

REMOVAL

- (1) Upper spacer block: drill-out the rivet heads and remove them from the reinforcement plate (Fig. 40).
- (2) Lower spacer block: remove the screws from the door face (Fig. 41).
- (3) As applicable, remove the spacer block from the door window frame or door face.

INSTALLATION

- (1) As applicable, position the spacer block on the door window frame or door face.

REMOVAL AND INSTALLATION (Continued)

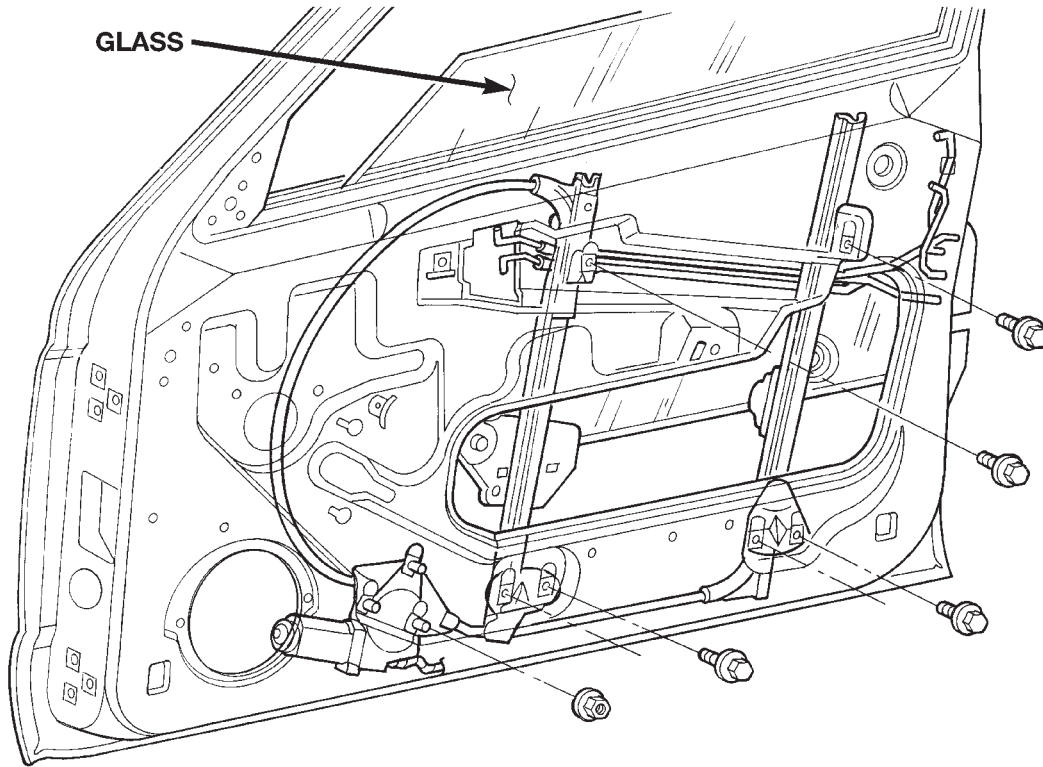

80a9f0f6

Fig. 39 Front Door Regulator

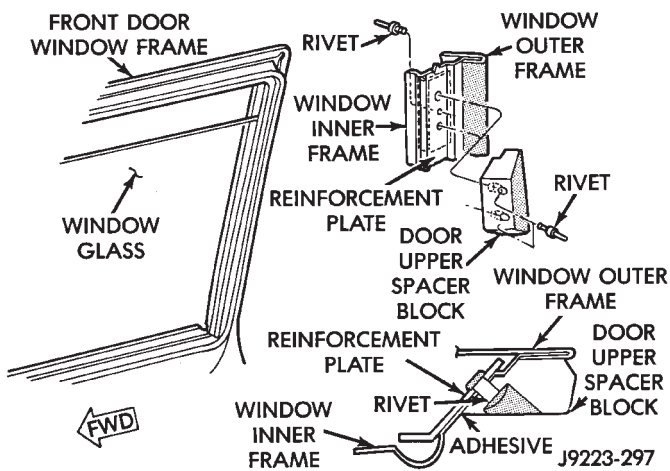

Fig. 40 Front Door Upper Spacer Block—Two-Door

- (2) Upper spacer block: Install the replacement rivets in the spacer block and reinforcement plate.
- (3) Lower spacer block: install the screws in the door face. Tighten the screws to 1 N·m (11 in-lbs) torque.

FRONT DOOR GLASS

REMOVAL

- (1) Remove the door trim panel.
- (2) Remove the waterdam.
- (3) Remove inner and outer belt weatherstrip.

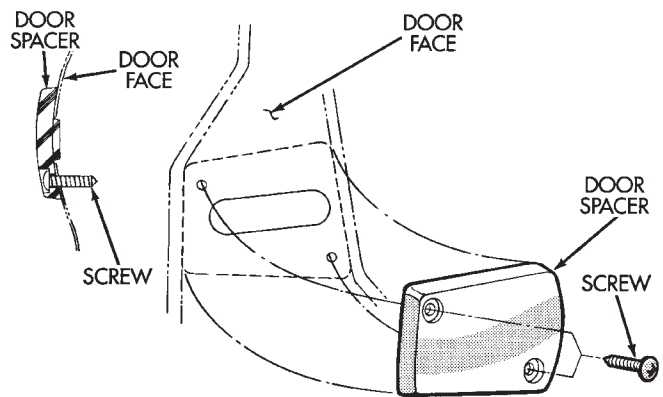

J9223-263

Fig. 41 Front Door Lower Spacer Block—Two-Door

- (4) Roll glass up to expose the bolts attaching the glass to the regulator.
- (5) Remove the bolts attaching the glass to the regulator (Fig. 42).
- (6) Lift the glass upward and out of the door.

INSTALLATION

- (1) Position the glass in the door.
- (2) Install the bolts attaching the glass to the regulator. Tighten the bolts to 4 N·m (36 in-lbs) torque.
- (3) Install inner and outer belt weatherstrip.
- (4) Attach the door waterdam to the door inner panel with adhesive/sealant.

REMOVAL AND INSTALLATION (Continued)

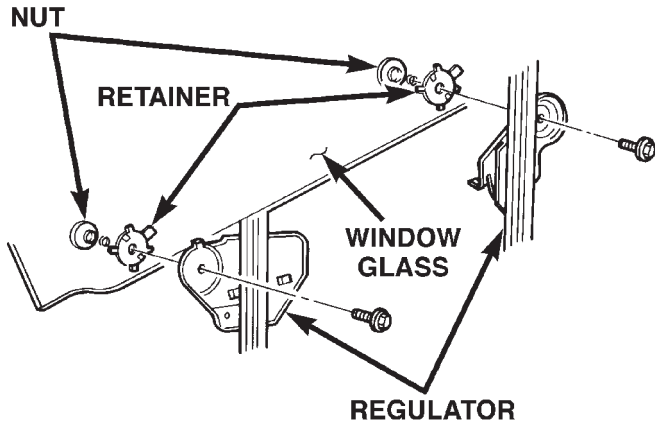

80aa4b5f

Fig. 42 Front Door Glass

- (5) Install the waterdam.
- (6) Install the door trim panel.

REAR DOOR TRIM PANEL

REMOVAL

- (1) Roll window down.
- (2) Remove window crank, if equipped (Fig. 43).
- (3) Remove the screws attaching the trim panel to the door inner panel (Fig. 44) and (Fig. 45).
- (4) Separate the trim panel fasteners from door inner panel with a pry tool (use special tool C-4829) (Fig. 46).
- (5) Lift the trim panel up and outward to separate from the inner belt seal.
- (6) Move the door trim panel outward and disconnect the handle-to-latch rods (Fig. 47).
- (7) Disconnect the power windows wire harness connectors, if equipped.
- (8) Remove the trim panel from door.

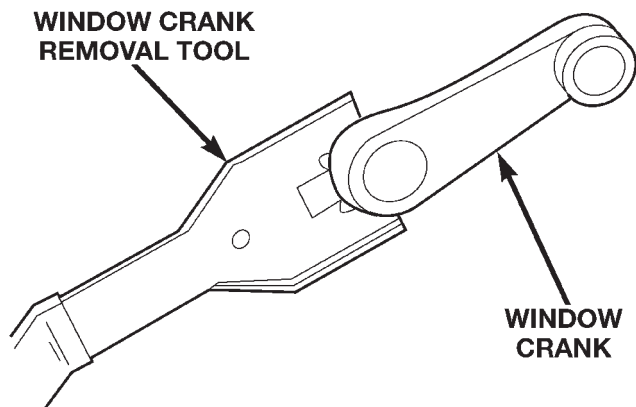

80ad2f28

Fig. 43 Window Crank—Typical

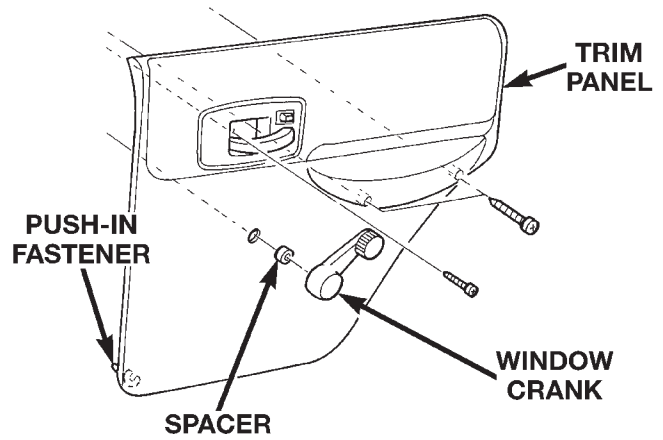

80afb5b

Fig. 44 Rear Door Trim Panel—Manual Window

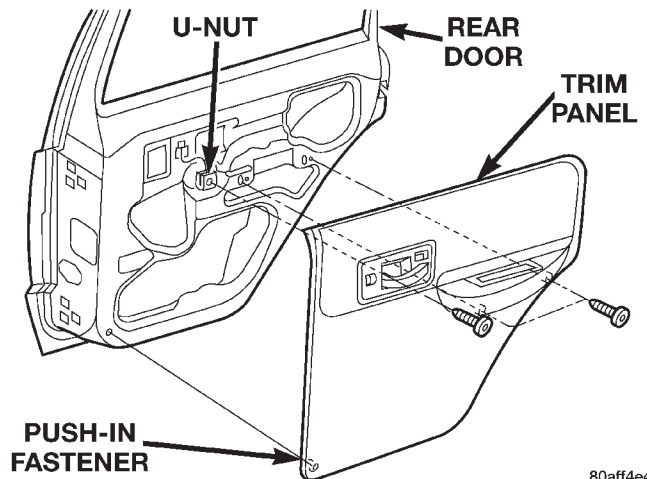

80aff4e4

Fig. 45 Rear Door Trim Panel—Power Window

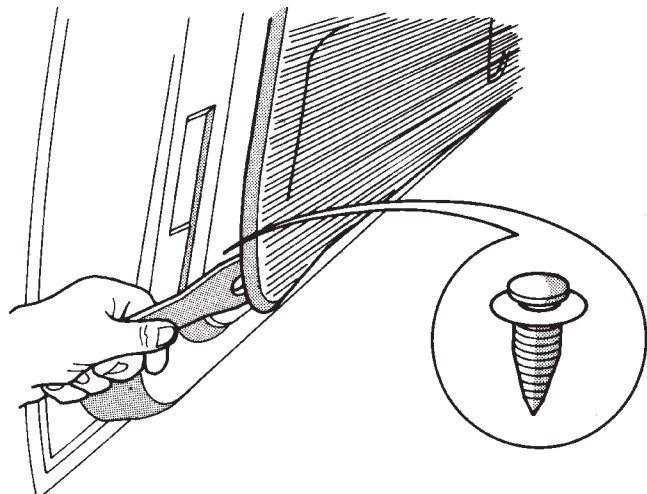

J898S-8

Fig. 46 Detaching Trim Panel Push-In Fasteners

REMOVAL AND INSTALLATION (Continued)

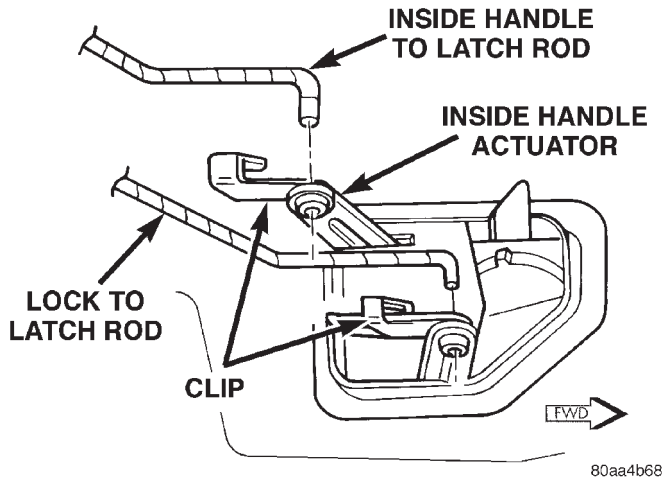

Fig. 47 Latch Rods

INSTALLATION

- (1) Replace any broken or damaged push-in fasteners.
- (2) Connect the power window wire harness connectors, if equipped.
- (3) Move the door trim panel outward and connect the handle-to-latch rods.
- (4) Position the trim panel on the inner belt seal and push down to seat.
- (5) Align the locating pins and push-in fasteners (Fig. 48). Press inward to secure.
- (6) Install the screws attaching the trim panel to the door inner panel.
- (7) Install the window crank, if equipped.

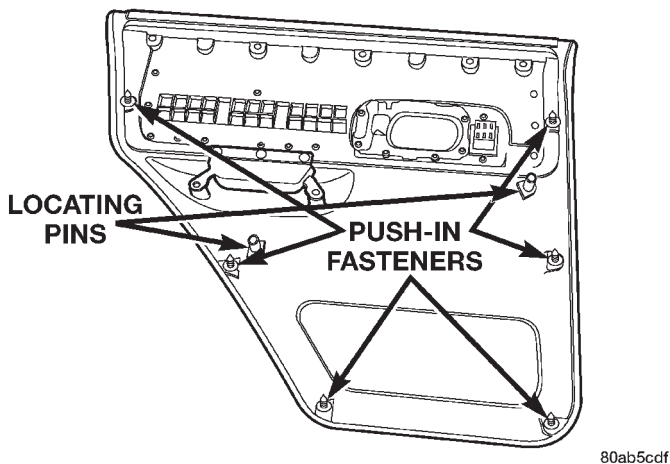

Fig. 48 Push-In Fasteners

REAR DOOR WATERDAM

REMOVAL

- (1) Remove door trim panel.
- (2) Peel the waterdam from the door.
- (3) Route the latch rods and wire harnesses through the waterdam.

- (4) Separate the waterdam from the door inner panel.

INSTALLATION

- (1) Route the latch rods and wire harnesses through the waterdam.
- (2) Position the waterdam on the door, apply adhesive as necessary and press into place.
- (3) Install door trim panel.

REAR DOOR

REMOVAL

- (1) Remove door restraint (check) retaining pin.
- (2) For vehicles equipped with power windows and power door locks, remove trim panel and waterdam. Disconnect all components and route wire harness out of door.
- (3) Remove bolts attaching hinge to door face.
- (4) Separate door from vehicle.

INSTALLATION

- (1) Position door in body opening.
- (2) Align door hinges, plates and shims and install bolts. Tighten bolts to 3 N·m (2 ft. lbs.) torque.
- (3) Install door restraint (check).
- (4) If applicable, route and connect wire harness connectors.
- (5) If necessary, install door waterdam and trim panel.

REAR DOOR RESTRAINT

REMOVAL

- (1) Remove the door trim panel.
- (2) Remove the door restraint (check) retaining pin from the bracket with a punch.
- (3) Remove the nuts and remove the restraint via the access opening in the door inner panel (Fig. 49).

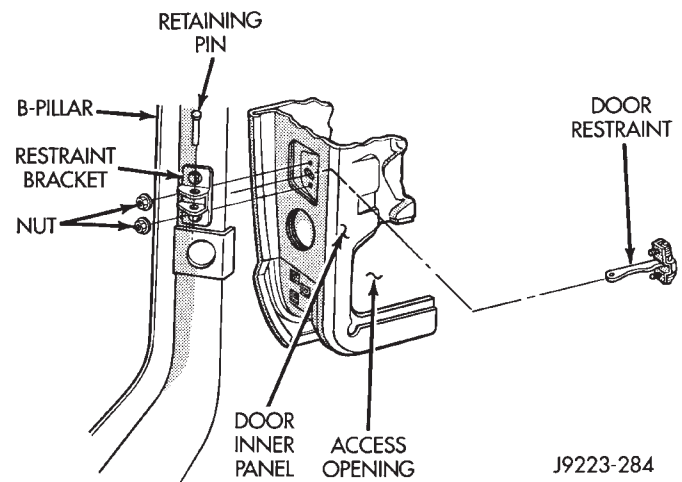

Fig. 49 Door Restraint (Check)

REMOVAL AND INSTALLATION (Continued)

INSTALLATION

(1) Position the door restraint in the door by way of the opening and install the nuts. Tighten the nuts to 10 N·m (7 ft-lbs) torque.

(2) Position the door restraint in bracket with the holes aligned and insert the retaining pin.

REAR DOOR HINGE

REMOVAL

- (1) Remove door restrain (check) pin.
- (2) Remove door hinge bolts and shims.
- (3) Retain bolts and shims for correct installation.

INSTALLATION

- (1) Position hinge plates and shims on door face.
- (2) Align door hinges and shims with bolt holes and install hinges. Tighten bolts to 3 N·m (2 ft. lbs.).
- (3) Adjust/align latch striker and latch as necessary.
- (4) Install door restrain (check) retaining pin.

REAR DOOR OUTSIDE HANDLE

REMOVAL

- (1) Remove the door trim panel.
- (2) Roll the window to the full up position.
- (3) Peel back the waterdam to access the fasteners for the outside handle.
- (4) Remove the latch.
- (5) Remove the access hole cover.
- (6) Remove the nuts attaching the door handle to the door (Fig. 50).
- (7) Disconnect the handle-to-latch rod from the handle latch release lever arm (Fig. 51).

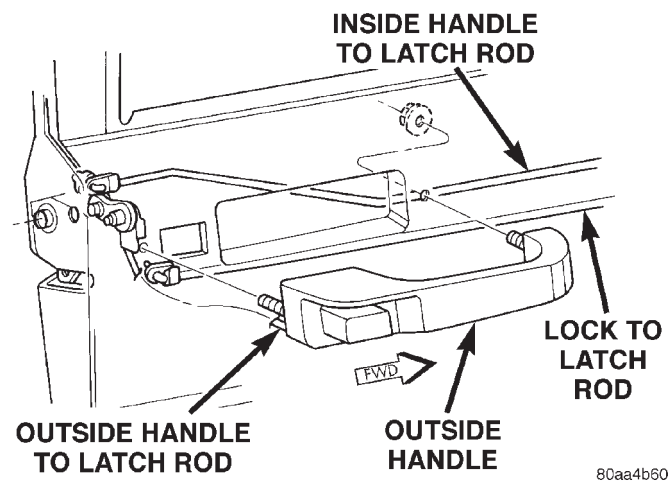

Fig. 50 Rear Door Outside Handle

INSTALLATION

- (1) Position the handle at the door panel.

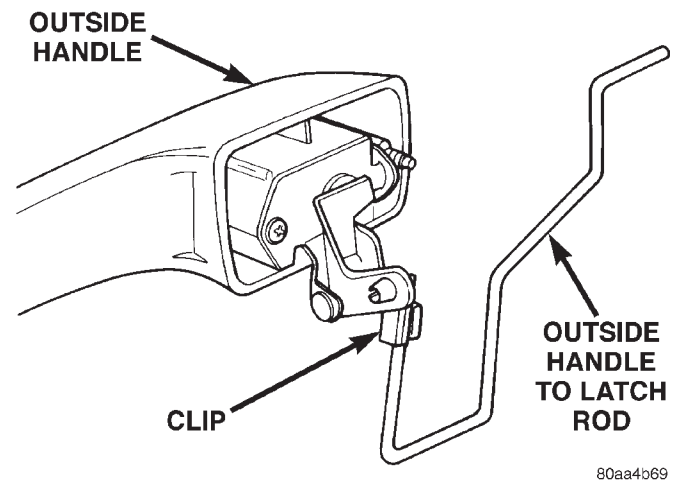

Fig. 51 Latch Rod

- (2) Connect the latch-to-handle rod to the handle latch release lever arm.
- (3) Install nuts attaching the door handle to the door.
- (4) Install the latch.
- (5) Install the waterdam.
- (6) Install the trim panel.

REAR DOOR LATCH

REMOVAL

- (1) Remove access plug.
- (2) Remove door trim panel.
- (3) Remove waterdam.
- (4) Remove screws attaching door latch to door (Fig. 52).
- (5) Disconnect all rods from door latch.
- (6) Remove door latch from door.

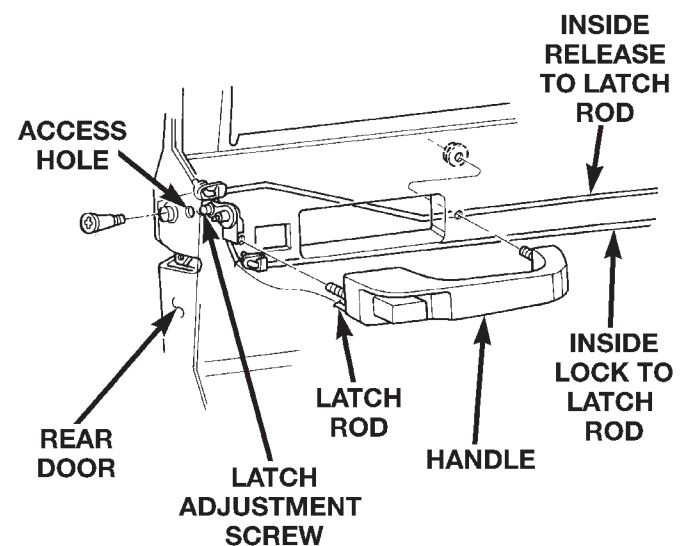

Fig. 52 Rear Door Latch

REMOVAL AND INSTALLATION (Continued)

INSTALLATION

- (1) Position door latch in door.
- (2) Connect all rods to door latch.
- (3) Install screws attaching door latch to door.
Tighten screws to 11 N·m (8 ft. lbs.) torque.
- (4) Install waterdam.
- (5) Install door trim panel.
- (6) Install access plug.

REAR DOOR LATCH STRIKER

REMOVAL

- (1) Using a grease pencil or equivalent, mark position of striker.
- (2) Remove screws attaching striker to C-pillar (Fig. 53).
- (3) Separate striker from C-pillar.

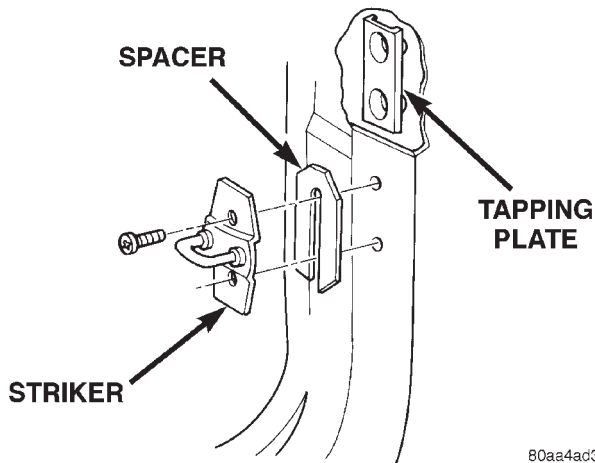

Fig. 53 Rear Door Latch Striker

INSTALLATION

- (1) Position and align striker on C-pillar.
- (2) Install screws attaching striker to C-pillar.
Tighten screws to 28 N·m (20 ft. lbs.) torque.

REAR DOOR INSIDE HANDLE ACTUATOR

REMOVAL

The rear door inside handle actuator is heat staked to the rear door trim panel during the manufacturing process.

- (1) Remove the door trim panel.
- (2) Using an X-ACTO knife or equivalent, cut the melted tabs securing the inside handle to the door trim panel.
- (3) Separate the inside handle from the trim panel.

INSTALLATION

- (1) Position the inside handle in the trim panel.
- (2) Heat stake the inside handle to the trim panel.
- (3) Install the door trim panel.

REAR DOOR INNER BELT WEATHERSTRIP

REMOVAL

- (1) Roll window down.
- (2) Remove door trim panel.
- (3) Pull up on the rear corner of the weatherstrip and lift from the door (Fig. 54).

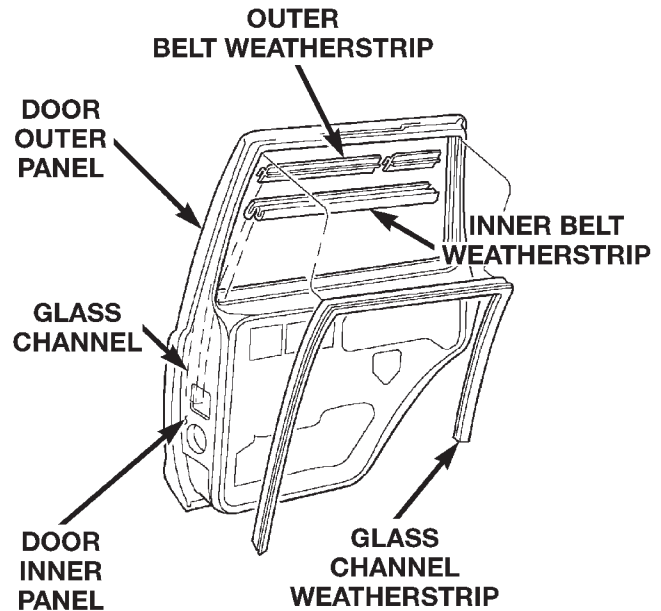

Fig. 54 Rear Door Inner/Outer Belt Weatherstrip

INSTALLATION

- (1) Position the weatherstrip on the door.
- (2) Push weatherstrip down to seat onto door.
- (3) Install door trim panel.

REAR DOOR OUTER BELT WEATHERSTRIP

REMOVAL

- (1) Roll window down.
- (2) Using a trim stick, pry up the rear outer corner of the weatherstrip.
- (3) Slowly and carefully, lift the weatherstrip up to separate from the door (Fig. 54).

INSTALLATION

- (1) Position the weatherstrip on the door.
- (2) Push weatherstrip down to seat onto door.

REAR DOOR GLASS RUN CHANNEL WEATHERSTRIP

REMOVAL

- (1) Remove door trim panel.
- (2) Remove waterdam.
- (3) Remove window glass.

REMOVAL AND INSTALLATION (Continued)

(4) Starting at rear corner, peel weatherstrip from around door frame (Fig. 54).

INSTALLATION

- (1) Starting at the top corner, press seal into place. A small amount of adhesive can be used to hold the weatherstrip in-place, if necessary.
- (2) As applicable, move downward evenly until the weatherstrip seal is fully seated in the channel.
- (3) Install window glass.
- (4) Install waterdam.
- (5) Install door trim panel.

REAR DOOR GLASS EXTERIOR MOLDING

REMOVAL

- (1) Open the window.
- (2) Remove the outer belt molding.
- (3) Pry and pull the molding sections from the door panel flange (Fig. 55).

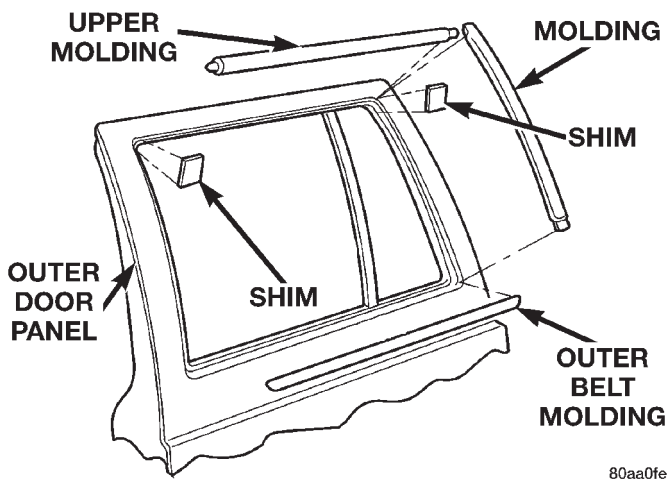

Fig. 55 Rear Glass Exterior Molding

INSTALLATION

- (1) Starting at the forward end of the upper molding, force the molding onto the door panel flange and continue rearward until it is completely seated on the flange.
- (2) Mate the rear molding with the upper molding and force the molding edge inward.
- (3) Continue pressing and moving downward to complete the installation.
- (4) Install the outer belt molding.

REAR DOOR WEATHERSTRIP

REMOVAL

- (1) Remove B-pillar upper trim.
- (2) Remove inner scuff plate.
- (3) Remove B-pillar lower trim.
- (4) Remove upper door opening trim.

(5) Grasp seal and separate from door opening (Fig. 56).

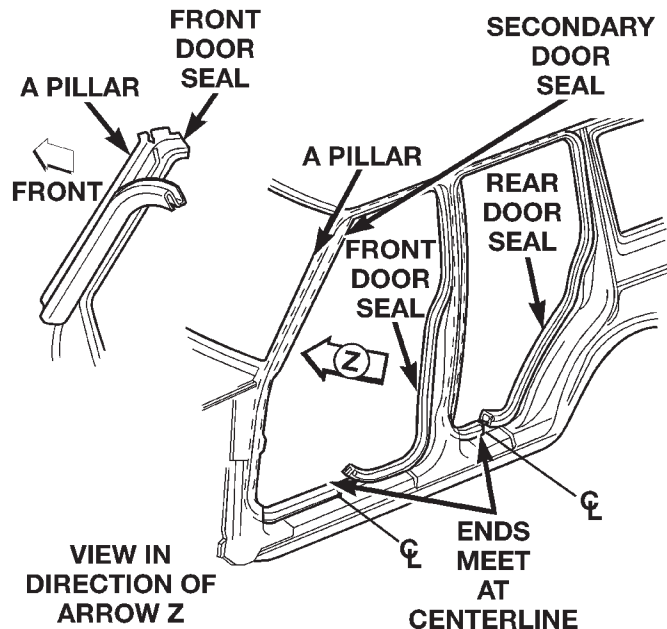

80aa0fd7

Fig. 56 Door Opening Weatherstrip

INSTALLATION

- (1) When installing a door opening weatherstrip seal, start at the door sill center line.
- (2) Move upward and around edge of door opening. Seat seal on flange.
- (3) Move upward and around the perimeter of the door opening and seat the weatherstrip on the flange (Fig. 57).
- (4) Install upper door opening trim.
- (5) Install inner scuff plate.
- (6) Install B-pillar lower trim panel.
- (7) Install B-pillar upper trim panel.

REAR DOOR WINDOW REGULATOR

REMOVAL

- (1) Remove the door trim panel.
- (2) Remove the waterdam.
- (3) Remove the bolt attaching the window glass to the regulator and support the glass (Fig. 58).
- (4) Remove the lower bolts attaching the regulator to the inner door panel (Fig. 59).
- (5) Remove the nuts attaching the regulator motor to the inner door panel, if equipped.
- (6) Loosen the upper bolt that attaches the regulator to the inner door panel.
- (7) Disconnect the wire harness connector from the regulator drive motor, if equipped.
- (8) Remove the regulator and drive motor, if equipped.

REMOVAL AND INSTALLATION (Continued)

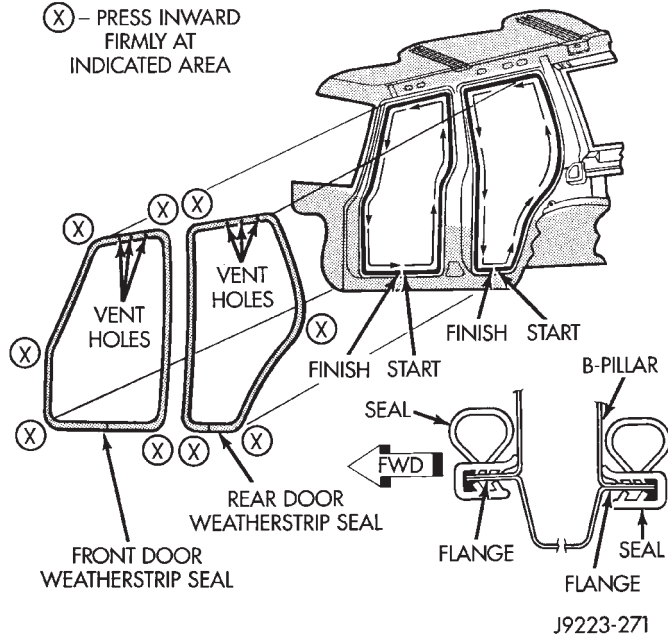

Fig. 57 Door Opening Weatherstrip

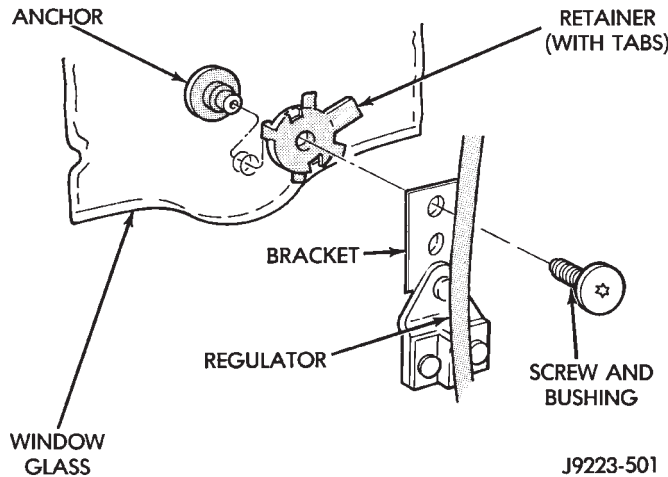

Fig. 58 Regulator To Glass Screw Removal/ Installation

INSTALLATION

- (1) Position window regulator and, if equipped, drive motor within the door panels.
- (2) Install the fasteners attaching the regulator to the door inner panel.
- (3) Connect the regulator wire harness connector.
- (4) Position the window glass at the regulator and install the retainer, bushing and bolt.
- (5) Install the waterdam.
- (6) Install the trim panel.

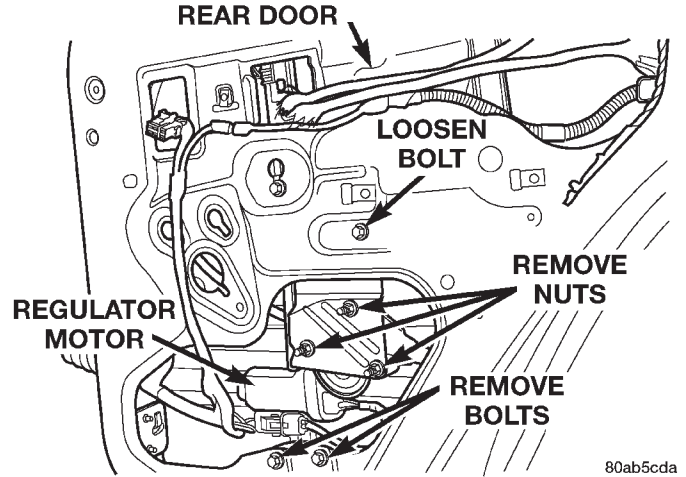

Fig. 59 Rear Door Window

REAR DOOR WINDOW GLASS

REMOVAL

- (1) Lower the window glass.
- (2) Remove the trim panel.
- (3) Remove the waterdam.
- (4) Remove inner and outer beltline weatherstrip.
- (5) Remove the window weatherstrip from the door.
- (6) Remove the division bar/stationary glass (Fig. 60).
- (7) Remove the window glass screw, bushing and retainer from the regulator.
- (8) Remove the window glass from door.

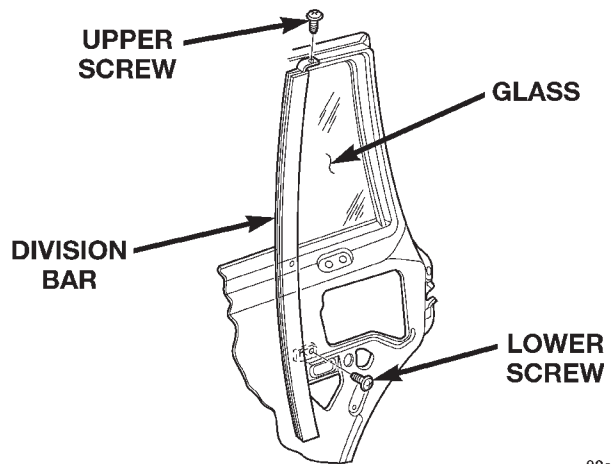

Fig. 60 Division Bar/Stationary Glass

INSTALLATION

- (1) Install the glass in the door, and install the retainer, bushing and screw.
- (2) Tighten the glass attaching screw 6 N-m (53 in-lbs) torque.
- (3) Install the division bar/stationary glass in the door.

REMOVAL AND INSTALLATION (Continued)

- (4) Install the glass run channel weatherstrip.
- (5) Install the inner and outer beltline weatherstrip.
- (6) Install the waterdam.
- (7) Install the trim panel.

BODY SIDE MOLDING

REMOVAL

- (1) Loosen the body side molding (Fig. 61) with a heat gun.
- (2) Lift edge of molding with a putty knife and peel molding from body panel. Apply heat to any location where the molding remains adhered to a panel.
- (3) Remove the adhesive from the body panel with Mopar Super Clean solvent or equivalent.
- (4) If the original molding will be installed, also remove all adhesive from it.

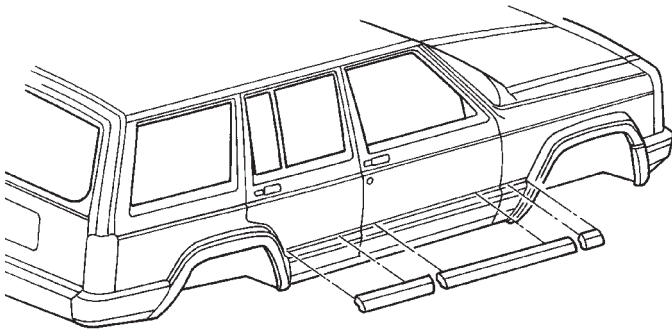

80aef1cb

Fig. 61 Body Side Molding—4-Door

INSTALLATION

- (1) If the original molding will be installed, apply 3M 5344 double-sided tape on the molding.
- (2) For vertical alignment, use masking tape or a string as reference.
- (3) Remove the backing from the tape, align the molding and position it on the body panel.
- (4) Press the molding onto the body panel with a roller or hand pressure.

REAR FENDER FLARE

REMOVAL

- (1) Remove the screw attaching the lower part of flare to the bottom of the fender.
- (2) Remove the nuts attaching the fender flare retainer to the wheelhouse liner (Fig. 62).
- (3) Separate the fender flare and retainer from the fender.

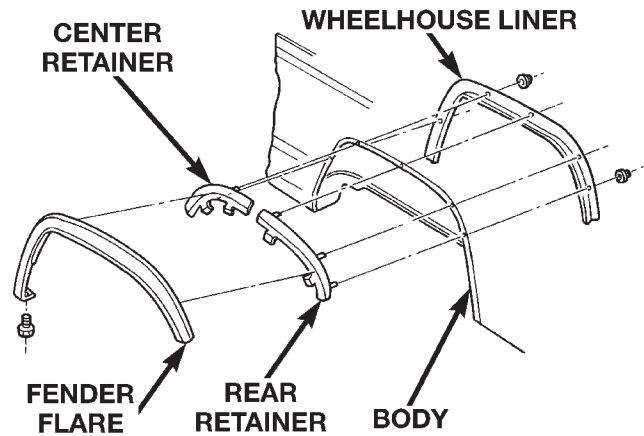

80aafb64

Fig. 62 Fender Flare

INSTALLATION

- (1) Position the fender flare and retainer on the fender.
- (2) Install the nuts attaching the fender flare and retainer to the wheelhouse liner.
- (3) Install the screw attaching the lower part of flare to the bottom of the fender.

QUARTER WINDOW APPLIQUE

REMOVAL

- (1) Remove the liftgate pillar trim.
- (2) Remove nuts from inside vehicle (Fig. 63).
- (3) Using a trim sick or equivalent, carefully pry the applique the from panel.

INSTALLATION

- (1) Position the replacement applique the on panel and install the nuts.
- (2) Install the liftgate pillar trim.

DRIP RAIL MOLDING

REMOVAL

- (1) Pry the clips from the roof flange.
- (2) Remove the clips and molding from the roof flange (Fig. 63).
- (3) Remove the remaining sealant and clean the roof flange.
- (1) Pry the clips from the roof flange.
- (2) Remove the clips and molding from the roof flange (Fig. 63).
- (3) Remove the remaining sealant and clean the roof flange.

INSTALLATION

- (1) Position the drip rail molding with clips at the roof flange and force the clips onto the roof flange.

REMOVAL AND INSTALLATION (Continued)

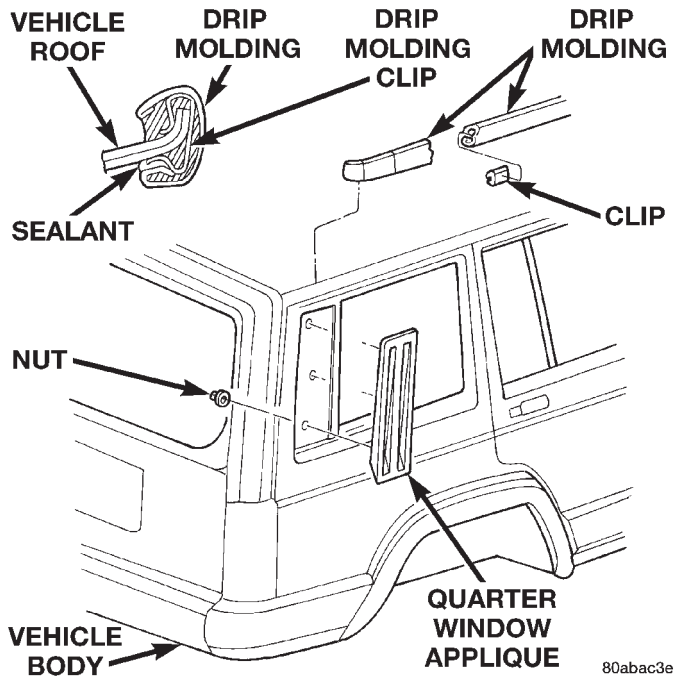

Fig. 63 Quarter Window Applique and Drip Molding

(2) Apply sealant to the inner side of the molding to seal the roof flange.

LUGGAGE RACK

REMOVAL

- (1) Remove slide rail screws (Fig. 64).
- (2) Remove luggage rack from roof.

NOTE: Skid strips are attached to roof panel with adhesive.

- (3) Loosen each skid strip with a heat gun.
- (4) Lift one edge of each skid strip with a putty knife and peel it from roof panel.
- (5) Remove original adhesive from roof with an adhesive removal solution.
- (6) If original skid strips are installed, remove all original adhesive from m.

INSTALLATION

- (1) Install 3M 06379 double-sided tape, or an equivalent on skid strips.
- (2) Remove backing from double-sided tape, align each skid strip on roof, and position it on roof panel.
- (3) Verify that each skid strip is properly aligned.
- (4) Press each skid strip onto roof panel with a roller (or use hand pressure).

NOTE: To prevent water leaks, apply 3M Drip-Chek Sealant, or equivalent.

- (5) Position luggage rack on roof with screw holes aligned.

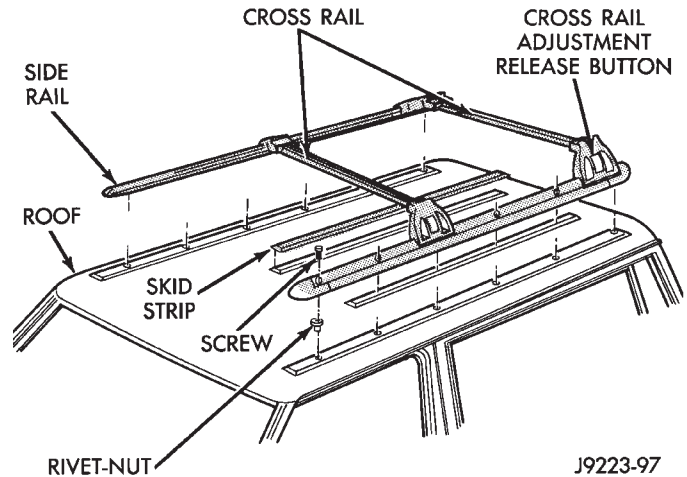

Fig. 64 Luggage Rack

(6) Install and tighten slide rail screws.

AIR EXHAUST GRILLE

REMOVAL

- (1) Remove the screw that attaches the grille to door the opening panel (Fig. 65).
- (2) Pry the bottom edge of the grille from the door opening panel.
- (3) Pull downward and remove the grille from exhaust port in the door opening panel.

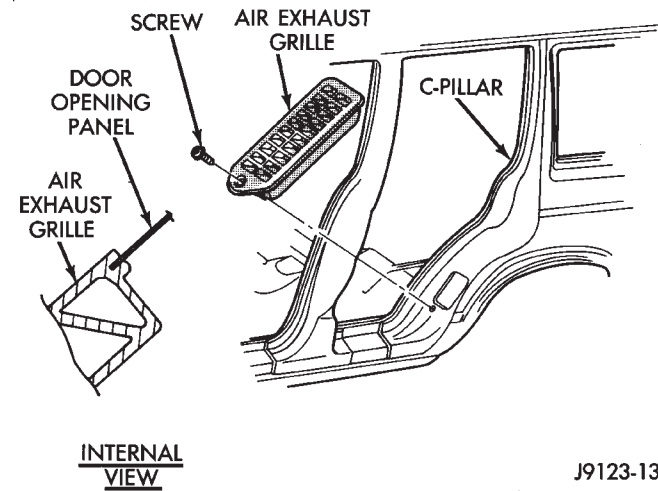

Fig. 65 Door Opening Air Exhaust Grille

INSTALLATION

- (1) Position the slot located in the upper end of replacement grille at the exhaust port and insert edge in the slot.
- (2) Push inward and seat the grille in the exhaust port.
- (3) Install the screw to attach the grille to the door opening panel.

REMOVAL AND INSTALLATION (Continued)

A-PILLAR TRIM

REMOVAL

- (1) Remove front and rear assist handles, if equipped.
- (2) Remove the inner scuff plate.
- (3) Remove the lower A-pillar cowl trim.
- (4) Using a small flat blade, pry the trim plugs from the A-pillar trim.
- (5) Remove the screws attaching the A-pillar trim to the A-pillar (Fig. 66).
- (6) Separate the A-pillar trim from the A-pillar.

INSTALLATION

- (1) Position the A-pillar trim on the A-pillar.
- (2) Install the screws attaching the A-pillar trim to the A-pillar.
- (3) Install the trim plugs.
- (4) Install the lower A-pillar cowl trim.
- (5) Install the inner scuff plate.
- (6) Install the assist handles.

LOWER A-PILLAR COWL TRIM

REMOVAL

- (1) Remove the inner scuff plate.

- (2) Remove the nut behind the fuse panel access door (Right side only) (Fig. 67).

- (3) Remove the fasteners attaching the lower A-pillar cowl trim to the A-pillar lower cowl.

- (4) Separate the lower A-pillar cowl trim from the A-pillar lower cowl.

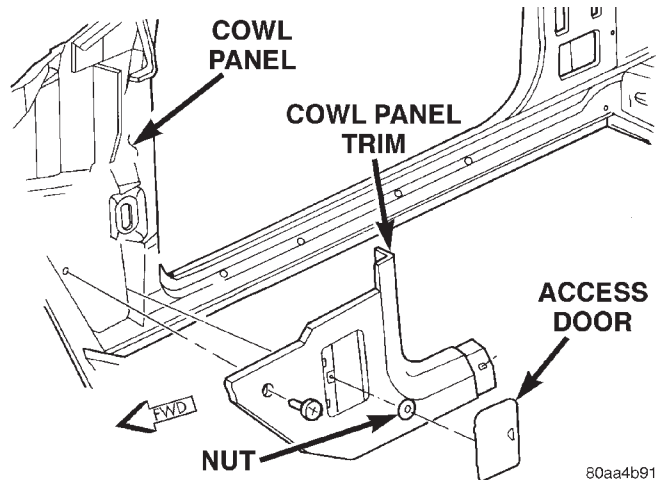

80aa4b91

Fig. 67 Lower A-Pillar Cowl Trim

INSTALLATION

- (1) Position the lower A-pillar cowl trim on the A-pillar lower cowl.

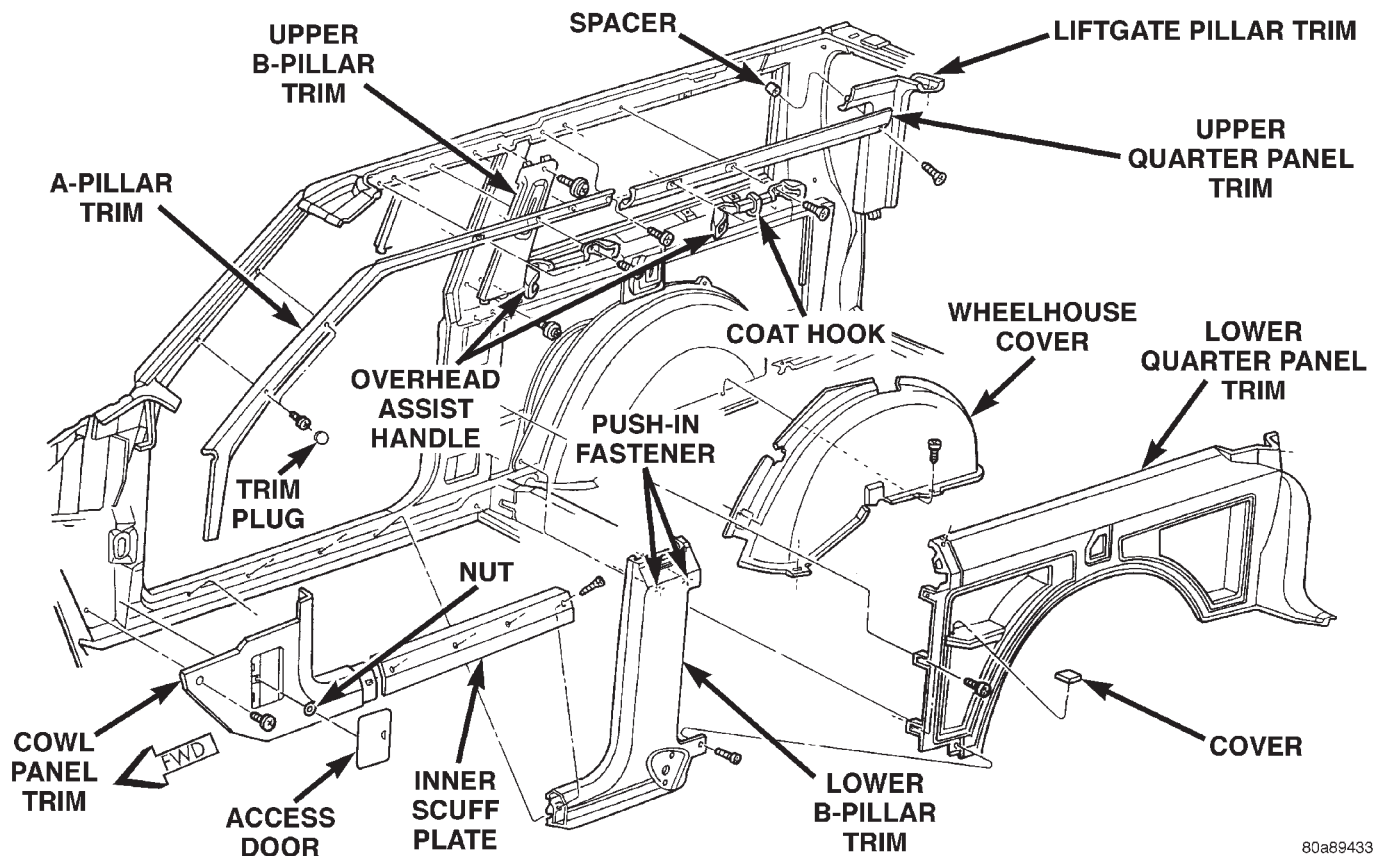

80a89433

Fig. 66 Trim Panels—2-Door Vehicles

REMOVAL AND INSTALLATION (Continued)

- (2) Install the screws attaching the lower A-pillar cowl trim to the A-pillar lower cowl.
- (3) Install the nut behind the fuse panel access door (Right side only).
- (4) Install the inner scuff plate.

FRONT INNER SCUFF PLATE

REMOVAL

- (1) If necessary, remove the bucket seat side shield trim cover.
- (2) Remove the screws attaching the inner scuff plate to the front door sill (Fig. 66).
- (3) Separate the inner scuff plate from the door sill.

INSTALLATION

- (1) Position the inner scuff plate on the front door sill.
- (2) Install the screws attaching the inner scuff plate to the front door sill.
- (3) If removed, install the bucket seat side shield trim cover.

DOOR SILL SCUFF PLATE

REMOVAL

- (1) Remove the screws attaching the door sill scuff plate to the door sill (Fig. 68).
- (2) Separate the scuff plate from the door sill.

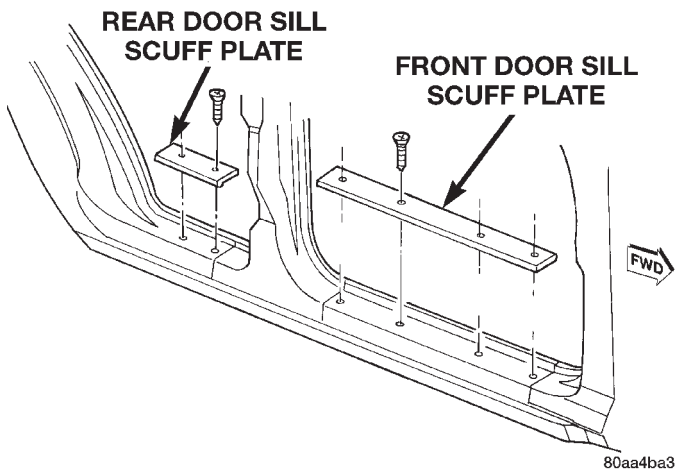

Fig. 68 Door Sill Scuff Plate

INSTALLATION

- (1) Position the scuff plate on the door sill.
- (2) Install the screws attaching the door sill scuff plate to the door sill.

ASSIST HANDLE

REMOVAL

- (1) Using a trim stick or equivalent, open the end covers to access the screws.
- (2) Remove the screws (Fig. 66).
- (3) Separate the assist handle from the trim.

INSTALLATION

- (1) Position the handle on the trim.
- (2) Install the screws.
- (3) Install the covers.

B-PILLAR TRIM

REMOVAL

- (1) Remove the inner scuff plate.
- (2) Remove the upper door opening trim (4-door vehicles) (Fig. 69).
- (3) Remove the upper quarter panel trim (2-door vehicles) (Fig. 66).
- (4) Remove the rear A-pillar trim screw.
- (5) Remove the shoulder belt turning loop.
- (6) Remove the seat/shoulder belt anchor bolt.
- (7) Remove the screws attaching the B-pillar trim to the B-pillar (2-door vehicles).
- (8) Route the shoulder belt through the lower B-pillar trim (2-door vehicles).
- (9) Separate the B-pillar trim from the B-pillar.

INSTALLATION

- (1) Route the shoulder belt through the lower B-pillar trim (2-door vehicles).
- (2) Position the B-pillar trim on the B-pillar and align push-in fasteners.
- (3) Press the B-pillar trim on the B-pillar to secure.
- (4) Install the screws attaching the B-pillar trim to the B-pillar (2-door vehicles).
- (5) Install the seat/shoulder belt anchor bolt.
- (6) Install the shoulder belt turning loop.
- (7) Install the A-pillar trim.
- (8) Install the upper quarter panel trim (2-door vehicles) (Fig. 66).
- (9) Install the upper door opening trim (4-door vehicles) (Fig. 69).
- (10) Install the inner scuff plate.

C-PILLAR TRIM

REMOVAL

- (1) Remove the inner scuff plate.
- (2) Remove the upper door opening trim.
- (3) Remove the upper quarter panel trim.
- (4) Remove the quarter panel trim extension.

REMOVAL AND INSTALLATION (Continued)

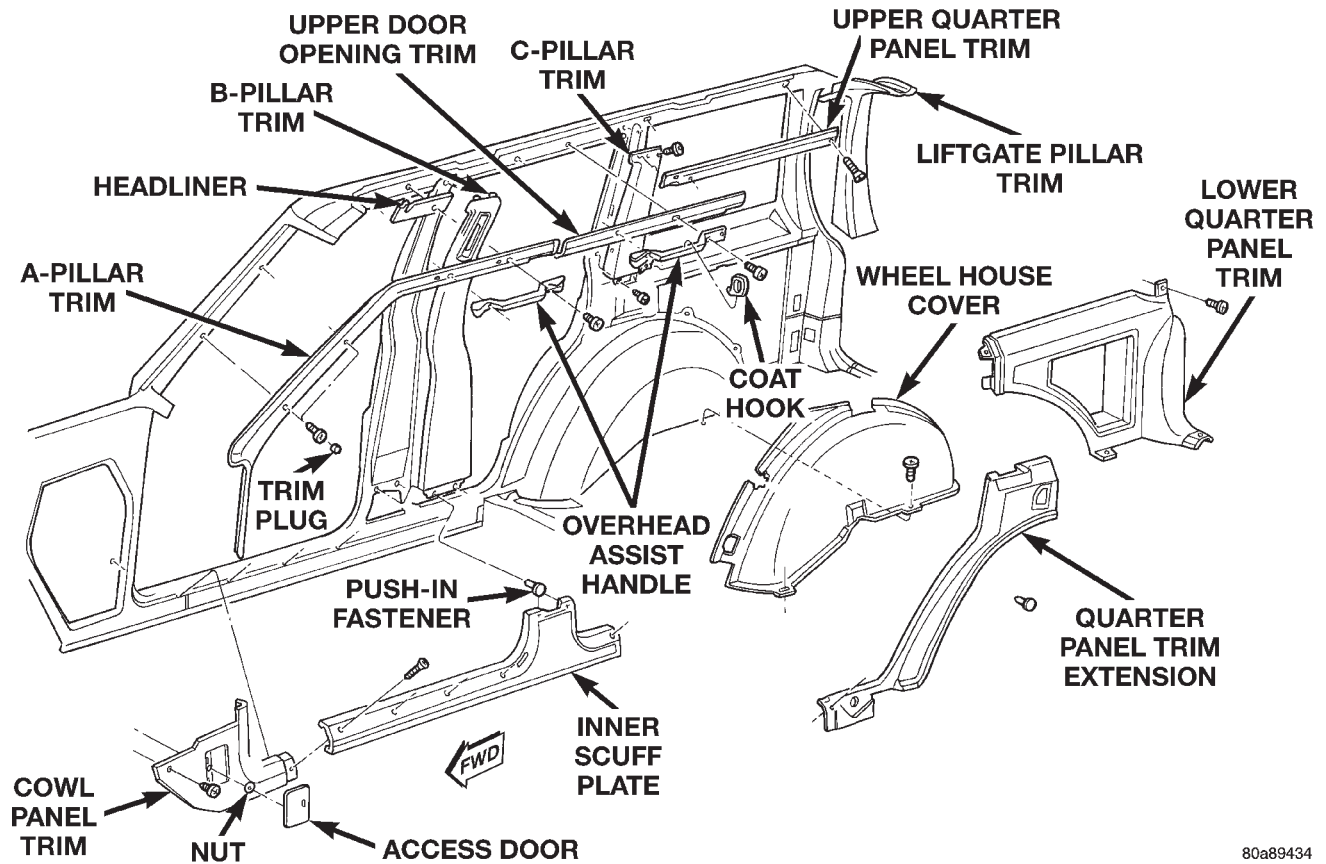

80a89434

Fig. 69 B-Pillar Trim—4-Door Vehicles

(5) Remove the screws attaching the C-pillar trim to the C-pillar (Fig. 69).

(6) Separate the C-pillar trim from the C-pillar.

INSTALLATION

- (1) Position the C-pillar trim on the C-pillar.
- (2) Install the screws attaching the C-pillar trim to the C-pillar.
- (3) Install the quarter panel trim extension.
- (4) Install the upper quarter panel trim.
- (5) Install the upper door opening trim.
- (6) Install the inner scuff plate.

QUARTER PANEL TRIM EXTENSION**REMOVAL**

- (1) Remove the inner scuff plate.
- (2) Separate quarter panel trim extension from the wheelhouse and quarter trim panels (Fig. 69).

INSTALLATION

- (1) Position the quarter panel trim extension on the wheelhouse and quarter trim panels.
- (2) Install the inner scuff plate.

QUARTER PANEL TRIM AND WHEELHOUSE COVER**REMOVAL**

- (1) Remove the inner scuff plate.
- (2) Remove quarter panel trim extension.
- (3) Remove liftgate scuff plate.
- (4) Remove the screws attaching the quarter panel trim from the quarter panel and wheelhouse trim cover (Fig. 69) and (Fig. 66).
- (5) If necessary, remove the tire and mounting brackets from the left quarter panel trim (Fig. 70).
- (6) Remove the screws attaching the wheelhouse cover to the wheelhouse.
- (7) Separate the wheelhouse cover from the wheelhouse.

INSTALLATION

- (1) Position the wheelhouse cover on the wheelhouse.
- (2) Install the screws attaching the wheelhouse cover to the wheelhouse.
- (3) If removed, install the tire and mounting bracket on the left quarter panel trim.
- (4) Position the quarter panel trim on the quarter panel and wheelhouse cover.

REMOVAL AND INSTALLATION (Continued)

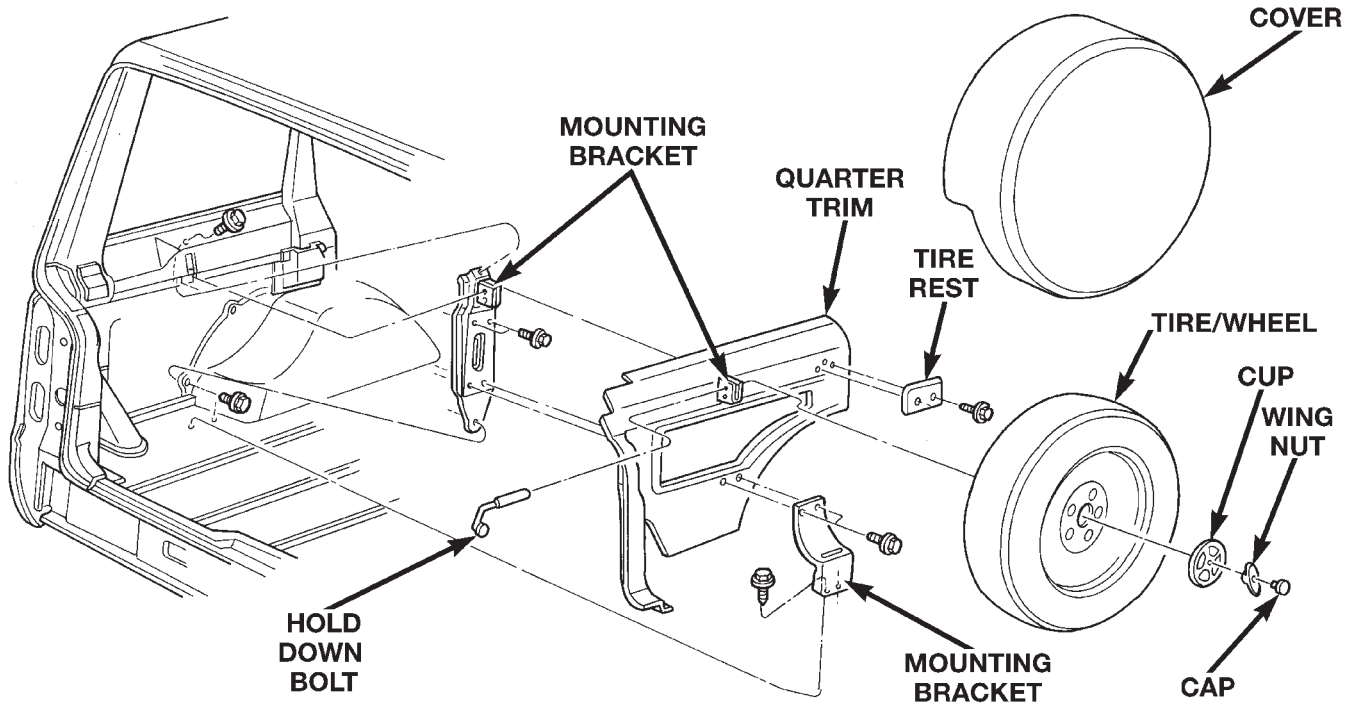

80a9f0f2

Fig. 70 Spare Tire

- (5) Install the screws attaching quarter panel trim on the quarter panel and wheelhouse cover.
- (6) Install liftgate scuff plate.
- (7) Install quarter panel trim extension.
- (8) Install the inner scuff plate.

LIFTGATE PILLAR TRIM

REMOVAL

- (1) Remove the liftgate opening upper trim.
- (2) Remove the liftgate pillar trim screws (Fig. 71).
- (3) Remove the screws attaching the lower quarter panel trim to the liftgate pillar.
- (4) Pull the trim panel outward to detach the spring steel clips attaching the trim panel to the pillar (2-dr vehicles).
- (5) Remove liftgate pillar trim.

INSTALLATION

- (1) Position the liftgate pillar trim on the liftgate pillar.
- (2) Press the trim panel into place to engage the spring steel clips attaching the trim panel to the pillar (2-dr vehicles).
- (3) Install the screws attaching the lower quarter panel trim to the liftgate pillar.
- (4) Install the liftgate pillar trim screws.
- (5) Install the liftgate opening upper trim.

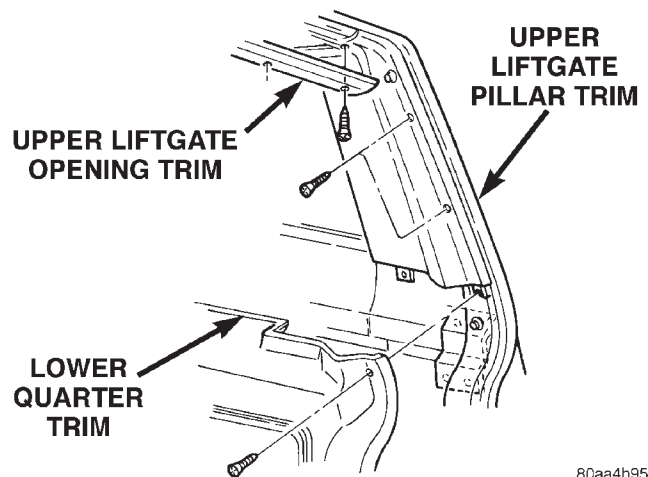

80aa4b95

Fig. 71 Liftgate Pillar Trim

LIFTGATE OPENING UPPER TRIM

REMOVAL

- (1) Remove the screws attaching the liftgate opening upper trim to the roof panel (Fig. 72).
- (2) Pull downward to disengage steel clips attaching the liftgate opening upper trim to the roof panel.
- (3) Separate trim from vehicle.

INSTALLATION

Steel clips are used for manufacturing purposes and are not required for service.

REMOVAL AND INSTALLATION (Continued)

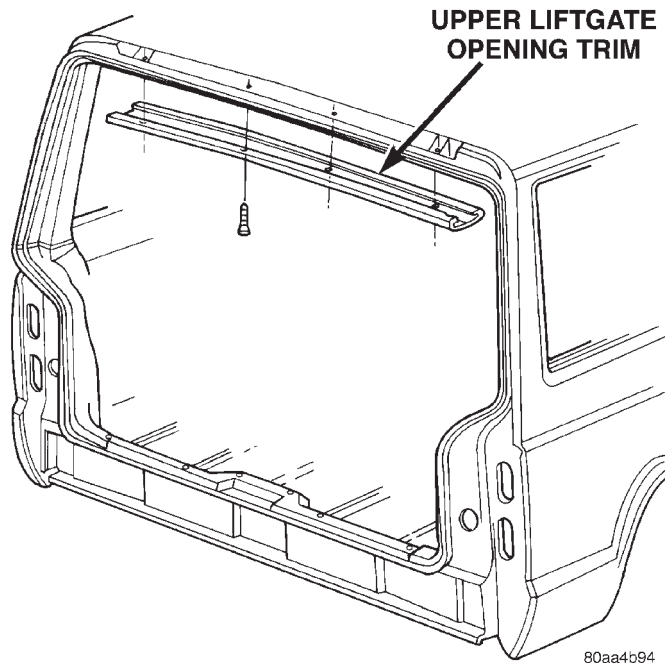
**Fig. 72 Liftgate Opening Upper Trim**

- (1) Position trim on roof panel.
- (2) Install the screws attaching the liftgate opening upper trim to the roof panel.

LIFTGATE SCUFF PLATE

REMOVAL

- (1) Remove the screws attaching the liftgate scuff plate to the floor pan (Fig. 73).
- (2) Separate the scuff plate from the vehicle.

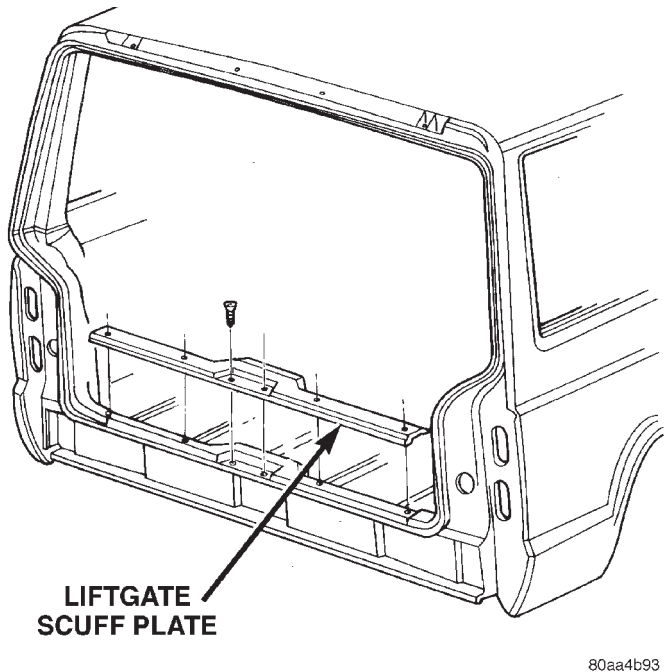
**Fig. 73 Liftgate Scuff Plate**

INSTALLATION

- (1) Position the scuff plate on the vehicle.
- (2) Center striker in opening.
- (3) Install the screws attaching the liftgate scuff plate to the floor pan.

FRONT SHOULDER BELT/BUCKLE

CAUTION: Inspect the front shoulder belts and buckles. Replace any belt that is either cut, frayed, torn or damaged in any way. Replace the shoulder belt if the retractor is damaged or inoperative.

REMOVAL

- (1) Slide the front seats all the way forward for access to the belt anchor bolt.
- (2) Disconnect the belt wire harness connector.
- (3) Remove the anchor bolt cover.
- (4) Remove the anchor bolt attaching the buckle to the seat.
- (5) Remove the turning loop cover concealing the shoulder belt upper anchor bolt.
- (6) Use a Torx bit to remove the upper anchor bolt (Fig. 74). Remove the support/guide washer.
- (7) Remove the inner scuff plate/trim panel from the door sill and remove the shoulder belt lower anchor bolt(s) with a Torx bit (Fig. 75) and (Fig. 76).
- (8) Remove the shoulder belt and the retractor.

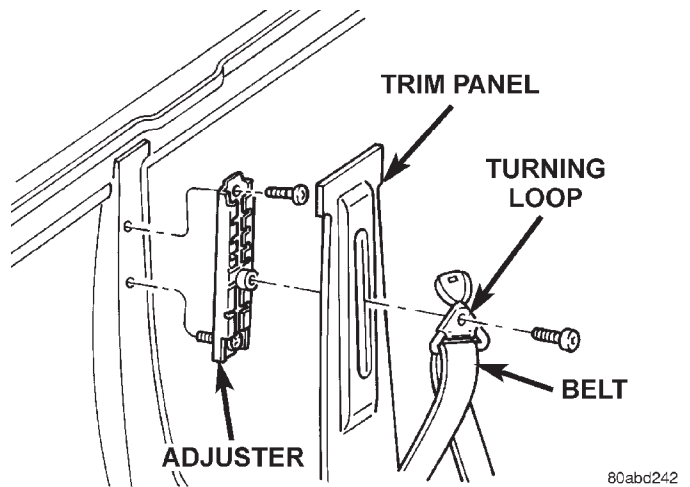
**Fig. 74 Anchor Bolt**

INSTALLATION

- (1) Position the shoulder belt retractor in the shield and install the lower anchor bolt with a Torx bit. Tighten bolt to 43 N·m (32 ft. lbs.) torque.
- (2) Position the support/guide washer and shoulder belt upper anchor plate on the trim panel. Install the upper anchor bolt with a Torx bit.
- (3) Route belt through trim panel.
- (4) Tighten the upper and lower anchor bolts to 43 N·m (32 ft. lbs.) torque.

REMOVAL AND INSTALLATION (Continued)

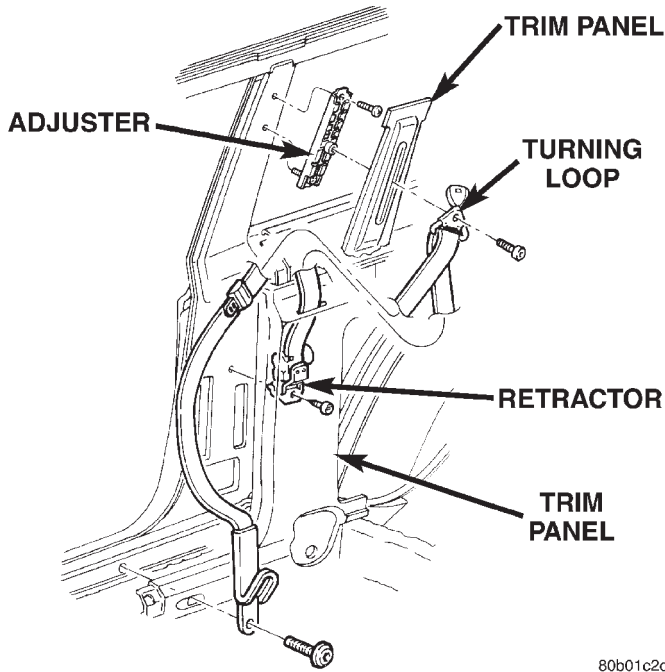

80b01c2d

Fig. 75 Front Shoulder Belt—2-Door Vehicles

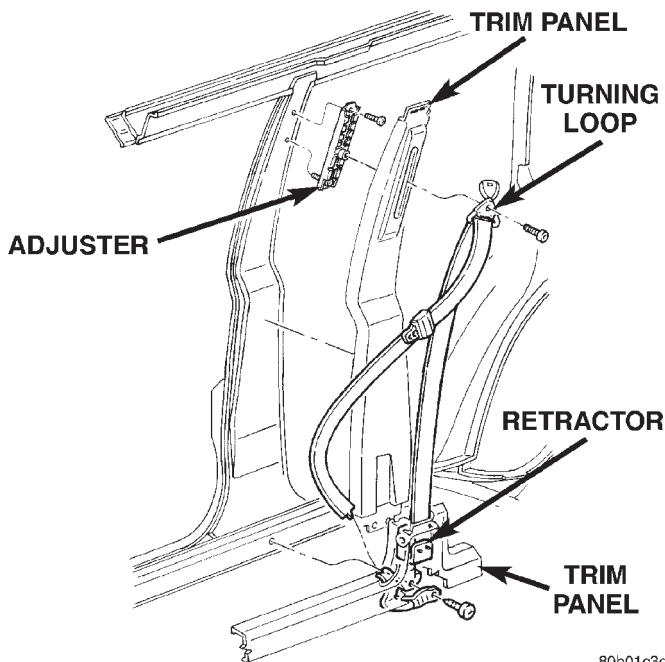

80b01c3c

Fig. 76 Front Shoulder Belt—4-Door Vehicles

- (5) Install the door sill inner scuff plate/trim panel and install the cap over the upper anchor bolt.
- (6) Install the shoulder belt buckle and anchor bolt. Connect the wire harness connectors. Tighten the buckle anchor bolt to 43 N·m (32 ft. lbs.) torque.

REAR SHOULDER/LAP BELT/BUCKLE

WARNING: Inspect rear shoulder/lap belts and buckles. Replace any belt that is either cut, frayed, torn or damaged in any way. Replace shoulder belt if retractor is damaged or inoperative.

REMOVAL

- (1) Pull rear seat release strap and tilt seat cushion forward.
- (2) Remove shoulder belt buckle and lap belt/buckle anchor plate bolts from floor pan (Fig. 77).
- (3) Remove shoulder belt lower outer anchor bolt.
- (4) Remove quarter trim panel. If necessary, refer to removal procedure.
- (5) Remove shoulder belt upper anchor bolt.
- (6) Remove bolt attaching retractor to rear quarter rail.
- (7) Separate retractor and shoulder belt from trim panel.

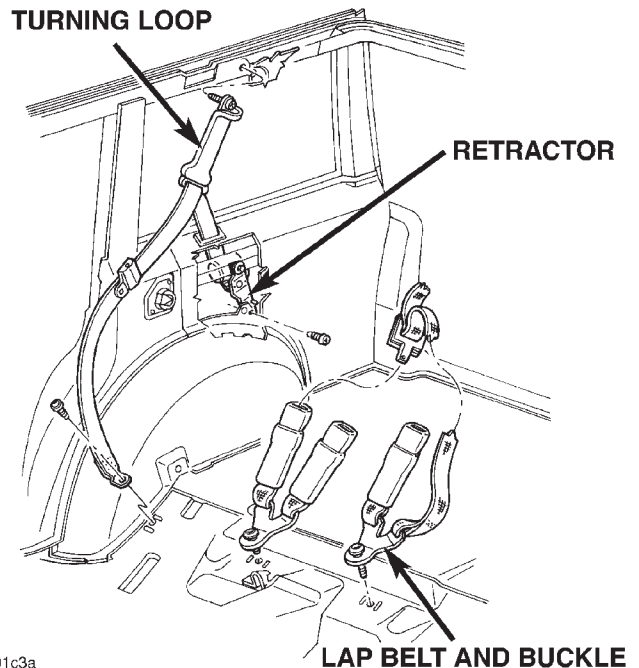

80b01c3a

Fig. 77 Rear Seat Shoulder/Lap Belts and Buckles INSTALLATION

- (1) Position shoulder belt buckle and lap belt/buckle anchor plates on floor panel.
- (2) Install anchor bolts. Tighten bolts to 43 N·m (32 ft. lbs.) torque.
- (3) Install retractor support on rear quarter rail. Tighten screw.
- (4) Route shoulder belt through quarter trim panel slot.

REMOVAL AND INSTALLATION (Continued)

(5) Position shoulder belt at roof rail and install upper anchor bolt. Tighten bolt to 43 N·m (32 ft. lbs.) torque.

(6) Install quarter trim panel.

(7) Install shoulder belt lower anchor bolt. Tighten bolt to 43 N·m (32 ft. lbs.) torque.

(8) Return rear seat cushion to normal position and engage latch.

FULL FLOOR CONSOLE

REMOVAL

(1) Remove the transmission shift lever handle/knob:

- Automatic transmissions, pull the handle straight upward to remove it.

- Insert a thin-blade tool under the edge of the transmission shift indicator bezel and pry up to remove.

- Manual transmissions, loosen the locknut and un-thread the shift knob from the shaft.

- Pull the shift boot up to remove.

(2) Insert a thin-blade tool under the edge of the transfer case shift indicator bezel or cover plate and pry up to remove.

(3) Open the console lid.

(4) Remove the screws attaching the console to the floor and mounting bracket (Fig. 78).

(5) Disconnect the wire harness connector.

(6) Separate the console from the floor.

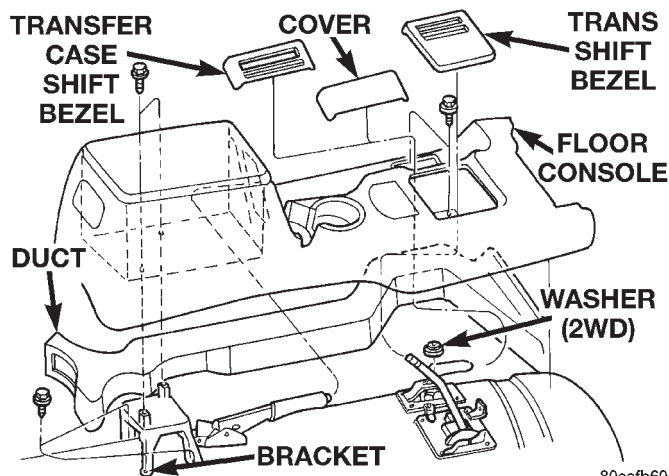

Fig. 78 Floor Console

INSTALLATION

(1) Position the console on the floor.

(2) Attach the air duct to the air outlet duct.

(3) Connect the wire harness connectors.

(4) Install the screws attaching the console to the mounting bracket.

(5) Install the shift indicator bezels (or cover plate).

(6) Install the shift lever handle/knob.

FRONT CARPET/MAT

REMOVAL

(1) Remove the door sill inner scuff plates.

(2) Remove the front and rear seats (as applicable).

(3) Remove floor console.

(4) As necessary, remove the trim panels and moldings.

(5) Remove all other interfering components.

(6) Remove the carpet and mat from the floor panel (Fig. 79).

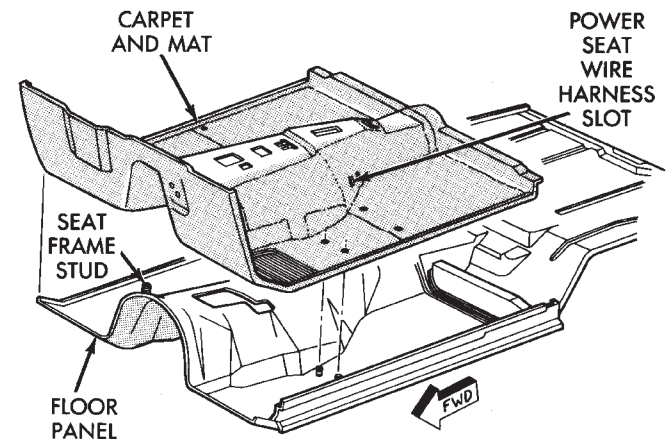

J9123-128

Fig. 79 Front Carpet and Mat

INSTALLATION

(1) Position the carpet and mat on the floor panel.

(2) Install all the components that were removed to facilitate carpet/mat removal.

(3) Install the trim panels and moldings.

(4) Install the door sill inner scuff plates.

(5) Install floor console.

(6) Install the front and rear seats (as applicable).

REAR CARPET/MAT

REMOVAL

(1) Remove the liftgate latch striker and scuff plate.

(2) Drill-out the retaining rivet heads and remove the cargo tie-down footman loops from the carpet.

(3) As necessary, remove the trim panels and moldings.

(4) Remove the all other interfering components.

(5) Remove the carpet and mat from the floor panel.

(6) If necessary, remove the insulation from the wheelhouse (Fig. 80).

INSTALLATION

(1) If removed, install the insulation on the wheelhouses.

REMOVAL AND INSTALLATION (Continued)

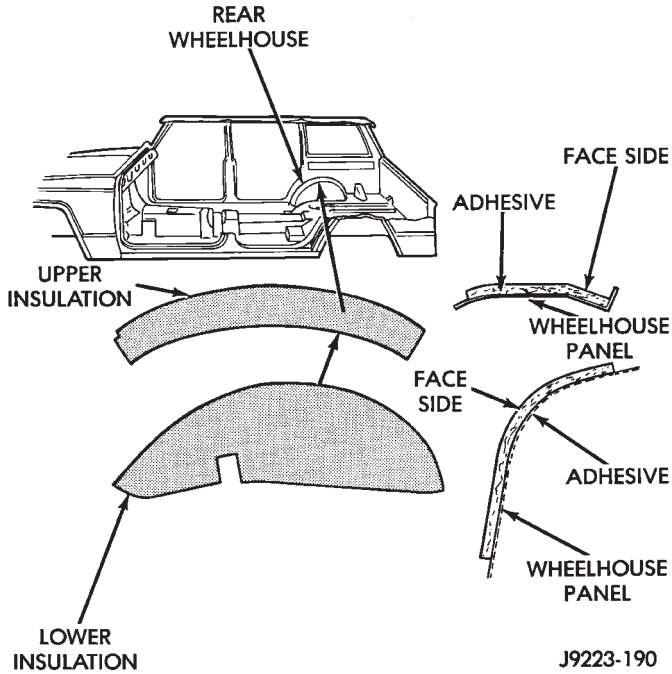

Fig. 80 Wheelhouse Insulation

- (2) Position the mat on the floor panel.
- (3) Position the carpet on the mat.
- (4) Install all the components that were removed to facilitate carpet and mat removal.
- (5) Install the trim panels and moldings.
- (6) Install the cargo tie-down footman loops on the carpet with replacement rivets.
- (7) Install the liftgate scuff plate and latch striker.

REARVIEW MIRROR

REMOVAL

- (1) Loosen the mirror base setscrew (Fig. 81).
- (2) Slide the mirror base upward and off the bracket.

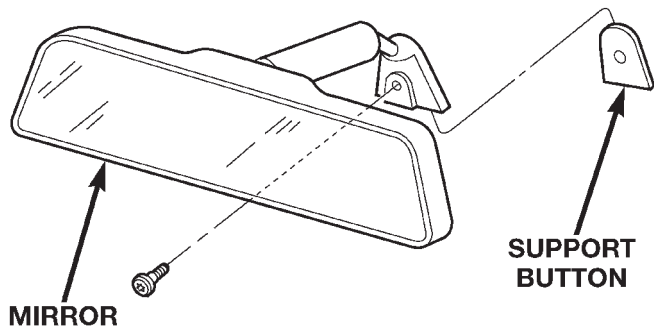

Fig. 81 Rearview Mirror

INSTALLATION

- (1) Position the mirror base at the bracket and slide it downward onto the support bracket.
- (2) Tighten setscrew to 1 N-m (9 in. lbs.) torque.

REARVIEW MIRROR SUPPORT BRACKET

INSTALLATION

- (1) Mark the position for the mirror bracket on the outside of the windshield glass with a wax pencil.
- (2) Clean the bracket contact area on the glass. Use a mild powdered cleanser on a cloth saturated with isopropyl (rubbing) alcohol. Finally, clean the glass with a paper towel dampened with alcohol.
- (3) Sand the surface on the support bracket with fine grit-sandpaper. Wipe the bracket surface clean with a paper towel.
- (4) Apply accelerator to the surface on the bracket according to the following instructions:
 - Crush the vial to saturate the felt applicator.
 - Remove the paper sleeve.
 - Apply accelerator to the contact surface on the bracket.
 - Allow the accelerator to dry for five minutes.
 - Do not touch the bracket contact surface after the accelerator has been applied.
- (5) Apply adhesive accelerator to the bracket contact surface on the windshield glass. Allow the accelerator to dry for one minute. Do not touch the glass contact surface after the accelerator has been applied.
- (6) Install the bracket according to the following instructions:
 - Apply one drop of adhesive at the center of the bracket contact-surface on the windshield glass.
 - Apply an even coat of adhesive to the contact surface on the bracket.
 - Align the bracket with the marked position on the windshield glass.
 - Press and hold the bracket in place for at least one minute.

NOTE: Verify that the mirror support bracket is correctly aligned, because the adhesive will cure rapidly.

- (7) Allow the adhesive to cure for 8-10 minutes. Remove any excess adhesive with an alcohol-dampened cloth.
- (8) Allow the adhesive to cure for an additional 8-10 minutes before installing the mirror.

REMOVAL AND INSTALLATION (Continued)

SUNVISORS

REMOVAL

(1) Remove the screws that attach the sunvisor arm support bracket to the headliner and the roof panel (Fig. 82) and (Fig. 83).

- (2) Disconnect vanity lamp connector, if equipped.
- (3) Detach the sunvisor from the support clip.
- (4) Remove the sunvisor from the vehicle.
- (5) Remove the retaining screw and support clip.

On vehicles equipped with an overhead console, the support clip is integral with the overhead console.

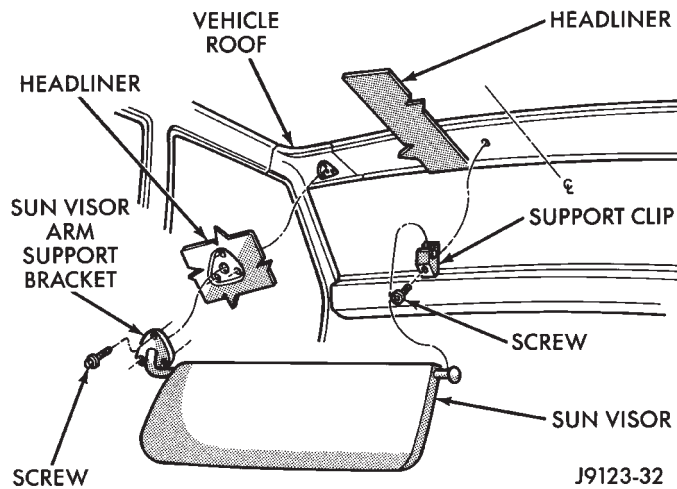

Fig. 82 Sunvisor

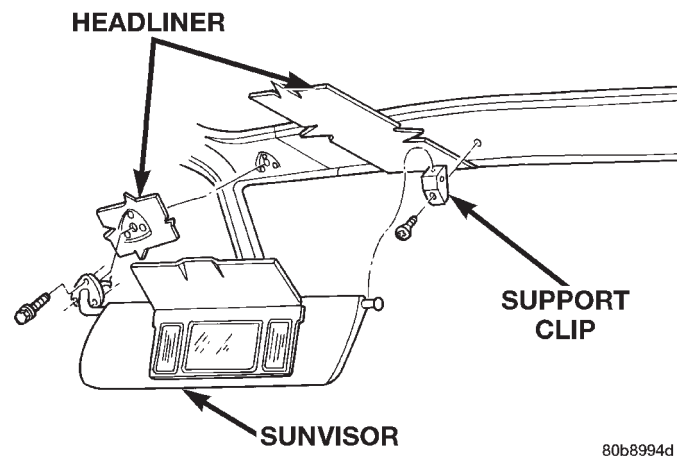

Fig. 83 Sunvisor w/Vanity Lamp

INSTALLATION

(1) Install the support bracket and the retaining screw.

(2) Connect vanity lamp connector, if equipped.

(3) Position the sunvisor in the support clip and align the arm support bracket holes with the headliner holes.

(4) Install the screws that attach the sunvisor arm support bracket to the headliner and the roof panel.

HEADLINER

The upper trim moldings and the headliner are attached to the roof rail with a combination of screws, clip retainers and rail retainers (Fig. 84).

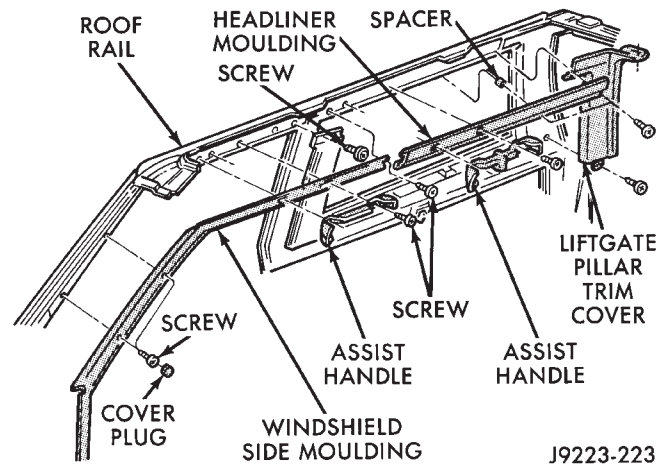

Fig. 84 Headliner Trim Moldings

To remove a headliner, all of the upper trim moldings must be removed from the perimeter of the headliner along with (as applicable):

- Assist handles.
- Sunvisors.
- Dome/cargo lamps.
- Overhead console.
- All other attached/overlapping components.

Refer to the appropriate removal and installation procedure locate in this section or in Group 8, Electrical.

REMOVAL

CAUTION: The headliner is a one-piece, molded component (Fig. 85). It has limited flexibility and must not be bent during removal/installation.

(1) Remove the upper trim moldings from the perimeter of the headliner (Fig. 86).

(2) Ensure that all the retainer clips and screws are disengaged before removing the headliner.

(3) Disengage tabs attaching headliner/speaker structure to roof rail, if equipped (Fig. 85).

(4) Disengage rear speaker harness connector, if equipped.

INSTALLATION

(1) Engage tabs attaching headliner/speaker structure to roof rail, if equipped. (Fig. 85)

(2) On vehicles without headliner speakers, ensure that the retainer clips on upper liftgate opening trim and rails are installed. (Fig. 87)

(3) Engage rear speaker harness connector.

REMOVAL AND INSTALLATION (Continued)

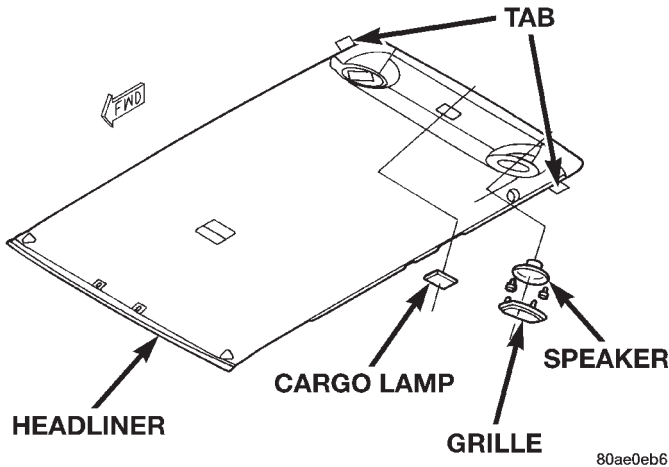

Fig. 85 Headliner

80ae0eb6

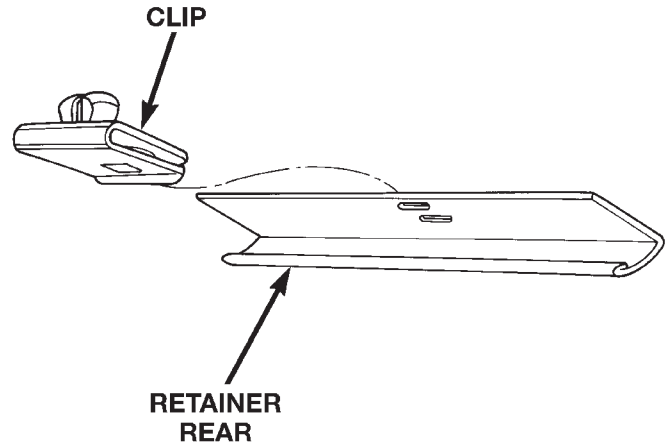

Fig. 87 Headliner Retainer Clip and Retainer Rail

80ae0eb4

(5) Remove the trim panel from the liftgate.

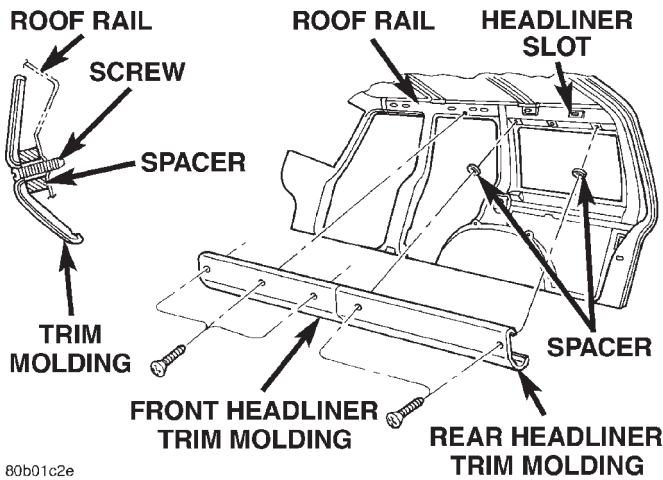

Fig. 86 Upper Trim Molding—4-Door

80b01c2e

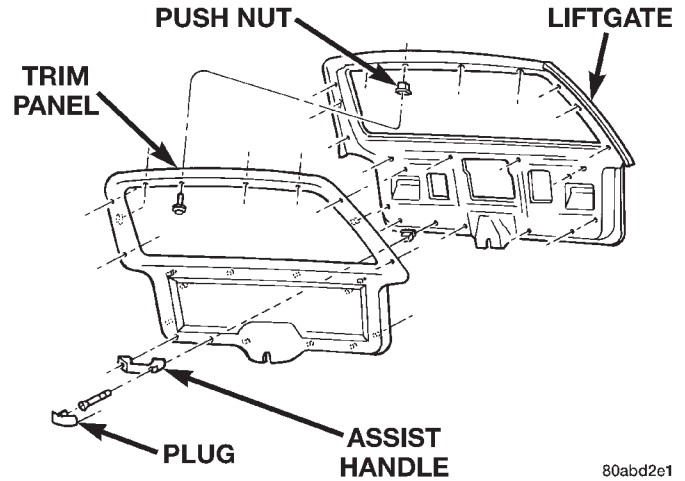

Fig. 88 Liftgate Trim Panel

80abd2e1

(4) Install the upper trim moldings around the perimeter of the headliner. Tighten the retaining screws to 1 N·m (11 in. lbs.) torque.

(5) As applicable, install:

- Assist handles.
- Sunvisors.
- Dome/cargo lamps.
- Overhead console.
- All other attached/overlapping components.

LIFTGATE TRIM PANEL

REMOVAL

- (1) Using a small flat blade, pry out the trim plugs from the liftgate assist handle.
- (2) Remove the screws attaching the assist handle to the liftgate (Fig. 88).
- (3) Remove the screws that attach the liftgate trim panel to the liftgate.
- (4) Using a trim panel removal tool, detach the push-in fasteners from the liftgate.

INSTALLATION

- (1) Position the trim panel on liftgate.
- (2) Using new push-in fasteners, align the push-in fasteners with the holes in the liftgate inner panel and press the trim panel into place.
- (3) Install the screws to attach the liftgate trim panel to the liftgate.
- (4) Install the screws attaching the assist handle to the liftgate.
- (5) Press the trim plugs into the liftgate assist handle.

REMOVAL AND INSTALLATION (Continued)

LIFTGATE

REMOVAL

WARNING: DO NOT DISCONNECT SUPPORT ROD CYLINDERS WITH LIFTGATE CLOSED. SUPPORT ROD PISTONS ARE OPERATED BY HIGH PRESSURE GAS. THIS COULD CAUSE DAMAGE AND/OR PERSONAL INJURY IF THEY ARE REMOVED WHILE PISTONS ARE COMPRESSED.

- (1) Remove center high mounted stop lamp (CHMSL).
- (2) Open and support liftgate.
- (3) Remove liftgate trim panel.
- (4) Disconnect and plug backlite washer fluid supply line.
- (5) Remove screws that attach rear wiper and liftgate power lock wire harness connectors to liftgate and disconnect connectors.
- (6) Using access hole created by removal of CHMSL, route backlite washer fluid supply line and rear wiper and liftgate power lock wire harness/grommets through access hole and separate from liftgate.
- (7) Remove retainer clips that secure support rods to ball studs.
- (8) Remove support rods from ball studs.
- (9) Remove bolts attaching hinges to liftgate.
- (10) Remove liftgate from vehicle.

INSTALLATION

- (1) Position and support liftgate at opening in body and install bolts attaching hinges to liftgate. Tighten bolts to 26 N·m (19 ft. lbs.) torque.
- (2) Connect liftgate support rods to ball studs and install retainer clips.
- (3) Route backlite washer fluid supply line and rear wiper and liftgate power lock wire harnesses/grommets through access hole.
- (4) Connect connectors and install screws that attach rear wiper and liftgate power lock wire harness connectors to liftgate.
- (5) Unplug and connect backlite washer fluid supply line.
- (6) Install liftgate trim panel.
- (7) Remove supports and close liftgate.
- (8) Install (CHMSL).

LIFTGATE HINGE

REMOVAL

It is not necessary to remove the liftgate to replace one or both hinges.

- (1) Open and support the liftgate.
- (2) Remove the liftgate opening upper trim.

(3) Remove the bolts attaching the hinge to the header panel (Fig. 89).

(4) Remove the bolts attaching the hinge to the liftgate.

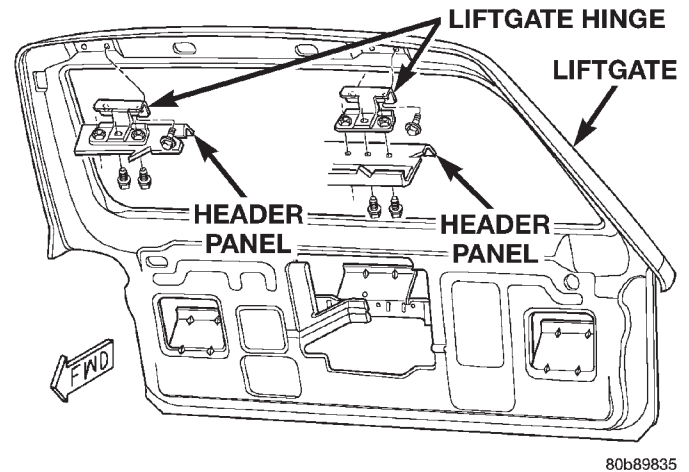

Fig. 89 Liftgate Hinge

INSTALLATION

- (1) Position the hinge on the liftgate.
- (2) Install the bolts attaching the hinge to the liftgate. Tighten to 26 N·m (19 ft. lbs.) torque.
- (3) Install the bolts attaching the hinge to the header panel. Tighten to 26 N·m (19 ft. lbs.) torque.
- (4) Install the liftgate opening upper trim.
- (5) Remove the support and close the liftgate.

LIFTGATE SUPPORT ROD CYLINDER

REMOVAL

WARNING: DO NOT REMOVE A SUPPORT ROD CYLINDER WITH THE LIFTGATE CLOSED. EACH SUPPORT ROD PISTON IS OPERATED BY HIGH PRESSURE GAS. IT CAN CAUSE DAMAGE AND/OR PERSONAL INJURY IF IT IS REMOVED WITH THE PISTON COMPRESSED. DO NOT ATTEMPT TO DISASSEMBLE OR REPAIR A SUPPORT ROD CYLINDER.

- (1) Open the liftgate.
- (2) Support the liftgate in the open position.
- (3) Remove the clip attaching the support rod to the ball stud.
- (4) Disconnect the support rod from the ball stud.
- (5) Remove the bolts attaching the support rod to the liftgate (Fig. 90).
- (6) Separate the support rod from the liftgate.

INSTALLATION

- (1) Position the support rod on the liftgate.
- (2) Install the bolts attaching the support rod to the liftgate.

REMOVAL AND INSTALLATION (Continued)

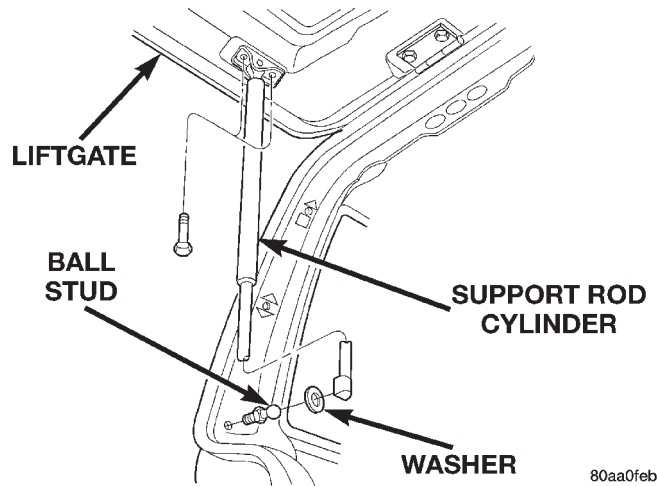

Fig. 90 Liftgate Support Rod

- (3) Connect the support rod to the ball stud.
- (4) Secure the support rod to the ball stud with the retainer clip.
- (5) Remove the support from the liftgate.

LIFTGATE SUPPORT ROD BALL STUD

REMOVAL

- (1) Open the liftgate.
- (2) Support the liftgate in the open position.
- (3) Remove the retainer clip attaching the support rod to the ball stud.
- (4) Disconnect the support rod from the ball stud.
- (5) Remove the ball stud.

INSTALLATION

- (1) Install the replacement ball stud.
- (2) Connect the support rod to the ball stud.
- (3) Secure the support rod to the ball stud with the clip.
- (4) Remove the support from the liftgate.

LIFTGATE OUTSIDE HANDLE

REMOVAL

- (1) Remove liftgate trim panel.
- (2) Disconnect liftgate actuator linkages.
- (3) Disconnect liftgate outside handle to latch rod.
- (4) Remove nut attaching outside handle to liftgate (Fig. 91).
- (5) Separate outside handle from liftgate.
- (6) If necessary, remove lock cylinder (Fig. 92).

INSTALLATION

- (1) If necessary, install lock cylinder.
- (2) Position outside handle on liftgate.
- (3) Install nut attaching outside handle to liftgate.
- (4) Connect liftgate outside handle to latch rod.
- (5) Connect liftgate actuator linkages.

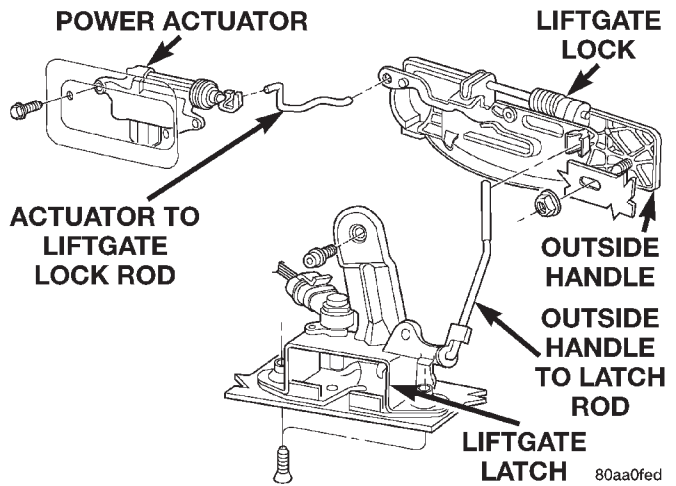

Fig. 91 Liftgate Outside Handle

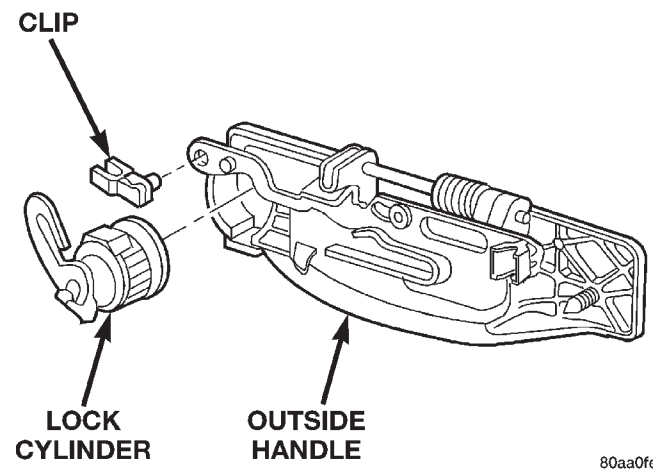

Fig. 92 Liftgate Lock Cylinder

- (6) Install liftgate trim panel.

LIFTGATE LOCK CYLINDER

For service procedures, refer to the Liftgate Outside Handle Removal/Installation procedures.

LIFTGATE LATCH

REMOVAL

- (1) Raise liftgate.
- (2) Remove liftgate trim panel.
- (3) Remove screws attaching latch to liftgate (Fig. 93).
- (4) Disconnect rod from latch.
- (5) Disconnect power lock connector from handle, if equipped.
- (6) Remove latch from liftgate.

INSTALLATION

- (1) Position latch in liftgate.

REMOVAL AND INSTALLATION (Continued)

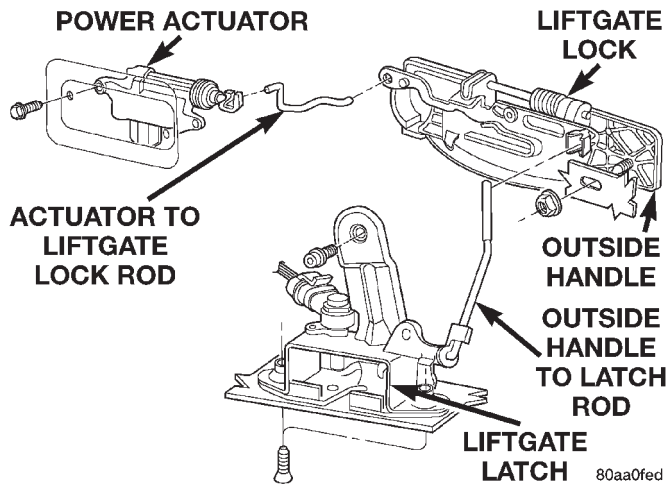

Fig. 93 Liftgate Latch

- (2) Connect power lock connector to handle, if equipped.
- (3) Connect latch rod.
- (4) Install screws attaching latch to liftgate. Tighten screws to 13 N·m (9 ft. lbs.) torque.
- (5) Install liftgate trim panel.

LIFTGATE LATCH STRIKER

REMOVAL

- (1) From underside of vehicle, remove nuts attaching striker to floor pan (Fig. 94).
- (2) Separate striker from vehicle.

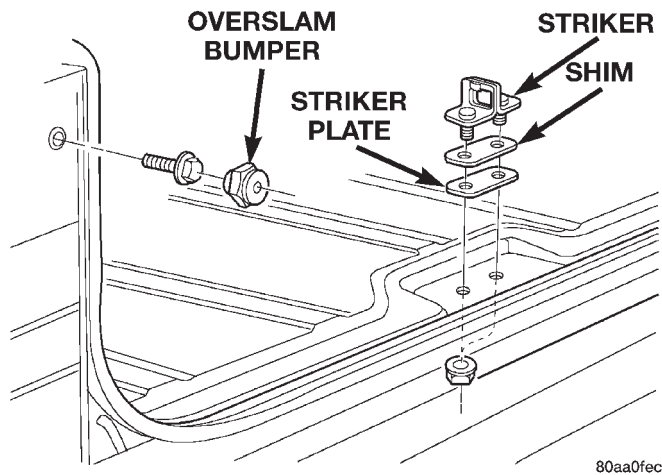

Fig. 94 Liftgate Striker

INSTALLATION

- (1) Position striker on vehicle.
- (2) Install nuts. Tighten nuts to 54 N·m (40 ft. lbs.) torque.

LIFTGATE WEATHERSTRIP

REMOVAL

- (1) Pull the seal away from the flange around the perimeter of liftgate opening and remove it.
- (2) Clean the flange as necessary.

INSTALLATION

- (1) Position weatherstrip seal in the opening with the left end of the seal at the opening centerline. Install the seal in a clockwise direction.
- (2) Move to the left and mate the seal with the bottom-left flange (Fig. 95).
- (3) Move upward and mate the seal with the left-side flange.
- (4) Move to the right and mate the seal with the top-left roof flange.
- (5) Seat the installed part of the seal with a roller. Move the roller from the left-bottom end of seal to the top-left half of the seal.
- (6) Move to the right and mate the seal with the top-right roof flange.
- (7) Move downward and mate the seal with the right-side flange.
- (8) Move to the left and mate the seal with the bottom-right flange.
- (9) Center and butt seal the ends together at the centerline.
- (10) Seat the remaining part of the seal with a roller. Move the roller the from top-left half of the seal to the right-bottom end of the seal.

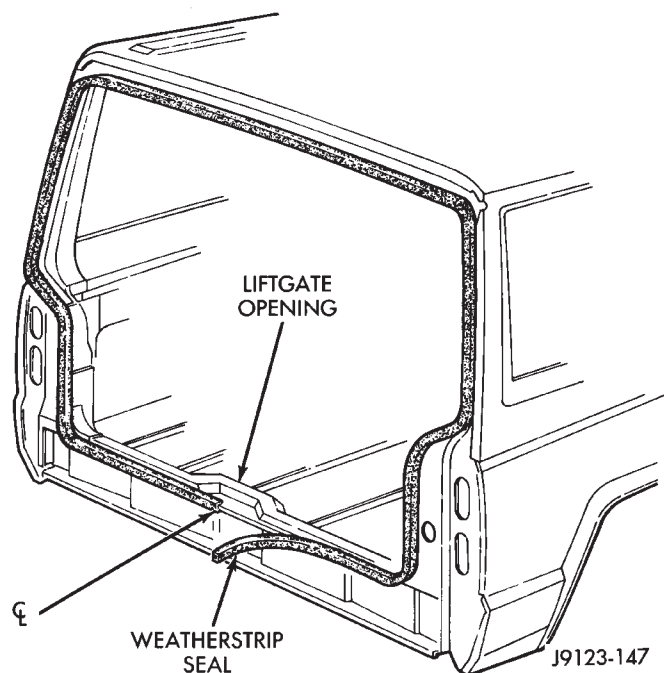

Fig. 95 Liftgate Weatherstrip Installation

ADJUSTMENTS

HOOD

The hood bolt holes are elongated for fore and aft and side-to-side adjustment.

- (1) If hood is low to the cowl panel, insert shims between the hinge and hood at the rear hinge bolts.
- (2) Adjust the hood bumper (Fig. 96) in or out to provide proper hood-to-fender height alignment.
- (3) Adjust the hood strikers (Fig. 97) with shims as necessary. Tighten the screws to 22 N·m (16 ft-lbs) torque after adjustment.
- (4) Align each latch and striker so that the striker enters latch squarely.

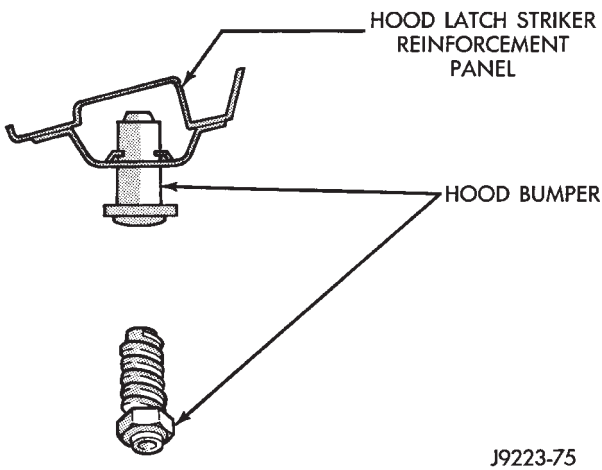

Fig. 96 Hood Bumper

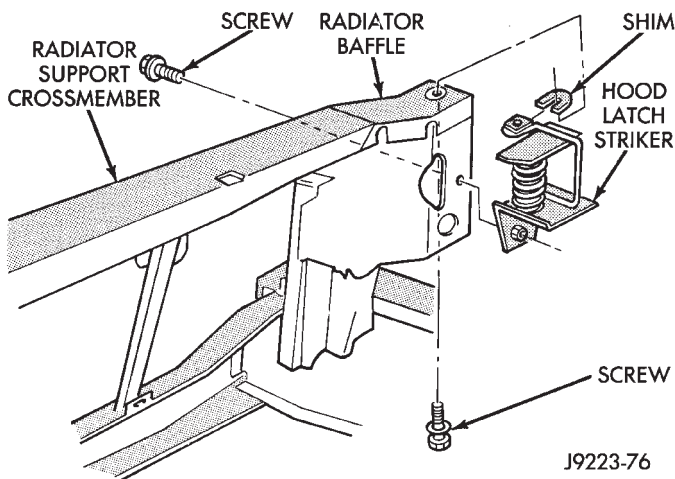

Fig. 97 Hood Latch Striker

DOOR

IN AND OUT—MINOR ADJUSTMENT

- (1) Loosen the latch striker.
- (2) Tap the latch striker inward if the door character line is outboard of the body character line or tap

the latch striker outward if the door character line is inboard of the body character line.

- (3) Inspect alignment. If correct, tighten striker with 28 N·m (20 ft. lbs.) torque.

UP AND DOWN—MINOR ADJUSTMENT

- (1) Loosen the latch striker.
- (2) Tap the latch striker downward if the door character line is higher than the body character line or tap the latch striker upward if the door character line is lower than the body character line.
- (3) Inspect alignment. If correct, tighten striker with 28 N·m (20 ft. lbs.) torque.

ALIGNMENT MAJOR—ADJUSTMENT

Adjustment for alignment of the door is made by installing shims between hinge and door face (Fig. 98).

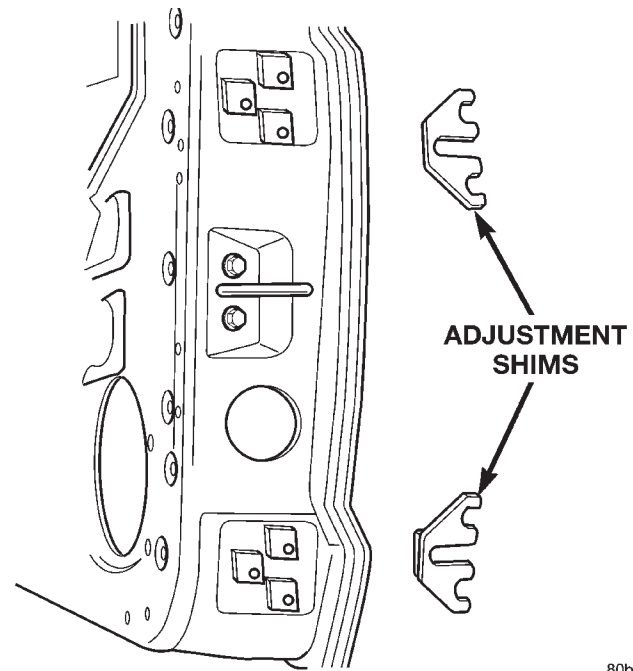

Fig. 98 Door Adjustment Shims

- (1) If not loosened, loosen the door hinge bolts.
- (2) Add or remove shims as necessary to obtain the best door fit.
- (3) Tighten door hinge bolts to 3 N·m (2 ft-lbs) torque after adjustment is completed.
- (4) Apply general purpose sealant around the door hinges/door face mating area.

DOOR LATCH ADJUSTMENT

- (1) Locate access hole (Fig. 99).
- (2) Insert a 5/32-inch hex-wrench through hole and into adjustment screw. Loosen screw.
- (3) Operate outside handle button several times to release any restriction because of mis-alignment.

ADJUSTMENTS (Continued)

(4) Tighten adjustment screw to 3 N-m (30 in-lbs) torque.

(5) Test handle button and lock cylinder for proper operation.

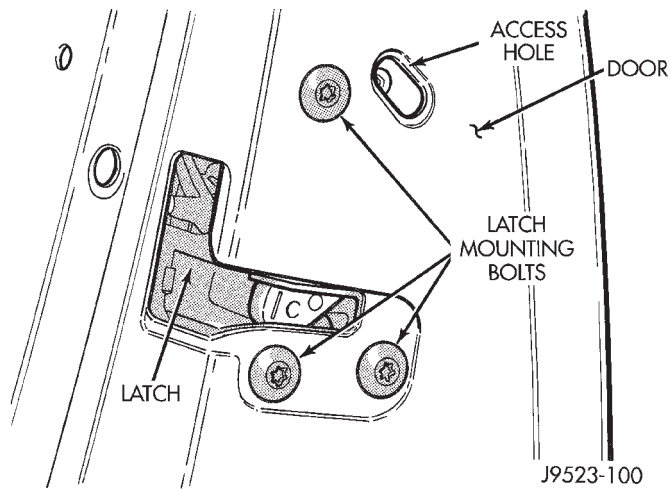

Fig. 99 Door Latch Adjustment

LIFTGATE

The position of liftgate can be adjusted upward or downward by use of slots in the hinge. An inward or outward adjustment is achieved by use of slots in the body. If an inward or outward adjustment is needed, use 3M™ Fast and Firm or equivalent on the hinge to body mating surface as a sealant.

REAR SEATBACK

(1) Unlatch and position seatback in cargo position.

(2) Loosen the screws attaching the strikers to the rear wheelhouse.

(3) Position the seat back in the full upright position and secure the latch into the strikers.

(4) From the cargo area of the vehicle, push the rear of the seatback forward.

(5) Unlatch and position seatback in cargo position.

(6) Tighten the screws attaching the strikers to the rear wheelhouse.

(7) Position the seat back in the full upright position and secure the latch into the strikers.

(8) Verify latch operation.

SPECIFICATIONS

BODY LUBRICANTS

COMPONENT	SERVICE INTERVAL	LUBRICANT
Door Latches	As Required	Multi-Purpose Grease NLGI GC-LB (Water Resistant) (1)
Hood Latch, Release Mechanism & Safety Latch	As Required (When Performing Other Underhood Service)	Multi-Purpose Grease NLGI GC-LB 2 EP (2)
Hood Hinges	As Required	Engine Oil
Seat Track & Release Mechanism	As Required	Multi-Purpose Grease NLGI GC-LB 2 EP (2)
Liftgate Hinge	As Required	Multi-Purpose Grease NLGI GC-LB 2 EP (2)
Liftgate Support Arms	As Required	Engine Oil
Liftgate Latches	As Required	White Spray Lubricant (3)
Liftgate Release Handle (Pivot & Slide Contact Surfaces)	As Required	Multi-Purpose Grease NLGI GC-LB 2 EP (2)
Window System Components	As Required	White Spray Lubricant (3)
Lock Cylinders	Twice A Year	Lock Cylinder Lubricant (4)
Parking Brake Mechanism	As Required	Multi-Purpose Grease NLGI GC-LB 2 EP (1)
1 = Mopar Wheel Bearing Grease (High Temp) 2 = Mopar Multi-Mileage Lubricant 3 = Mopar Spray White Lube 4 = Mopar Lock Cylinder Lubricant		

SPECIFICATIONS (Continued)

**WELD LOCATIONS
UPPER COWL**

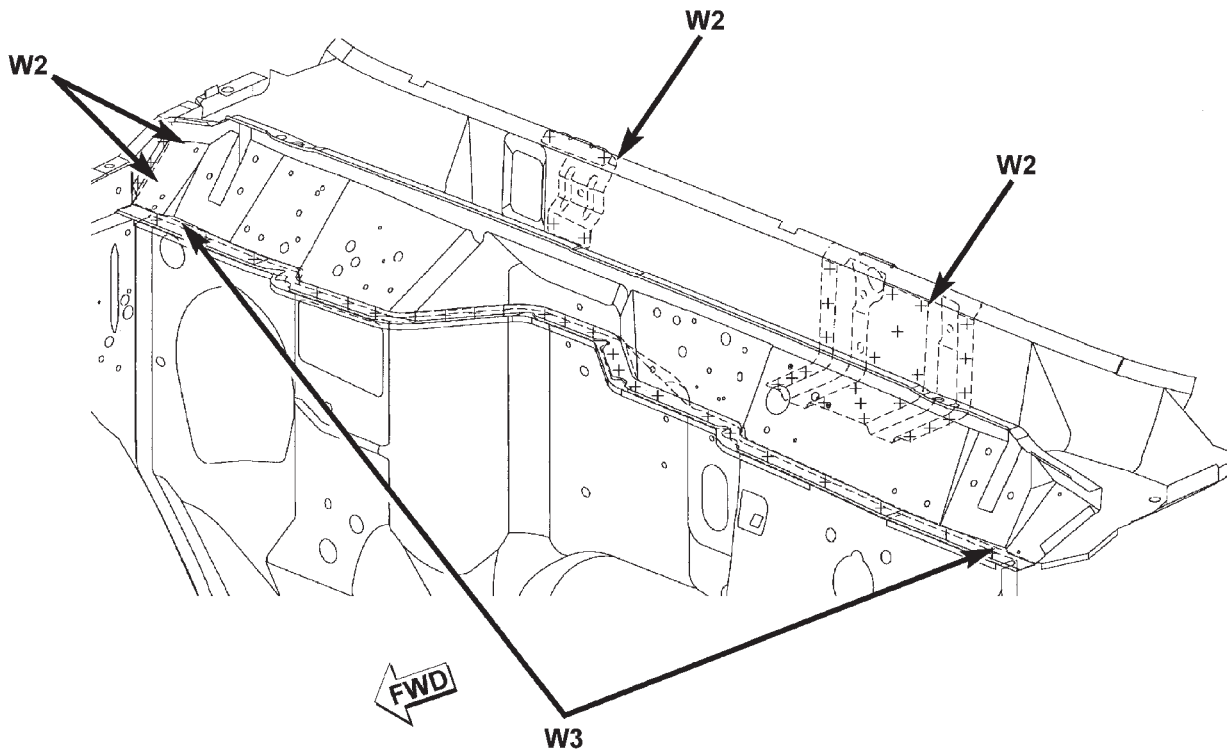

**W2 - WELDING OF 2 PARTS
W3 - WELDING OF 3 PARTS
W4 - WELDING OF 4 PARTS**

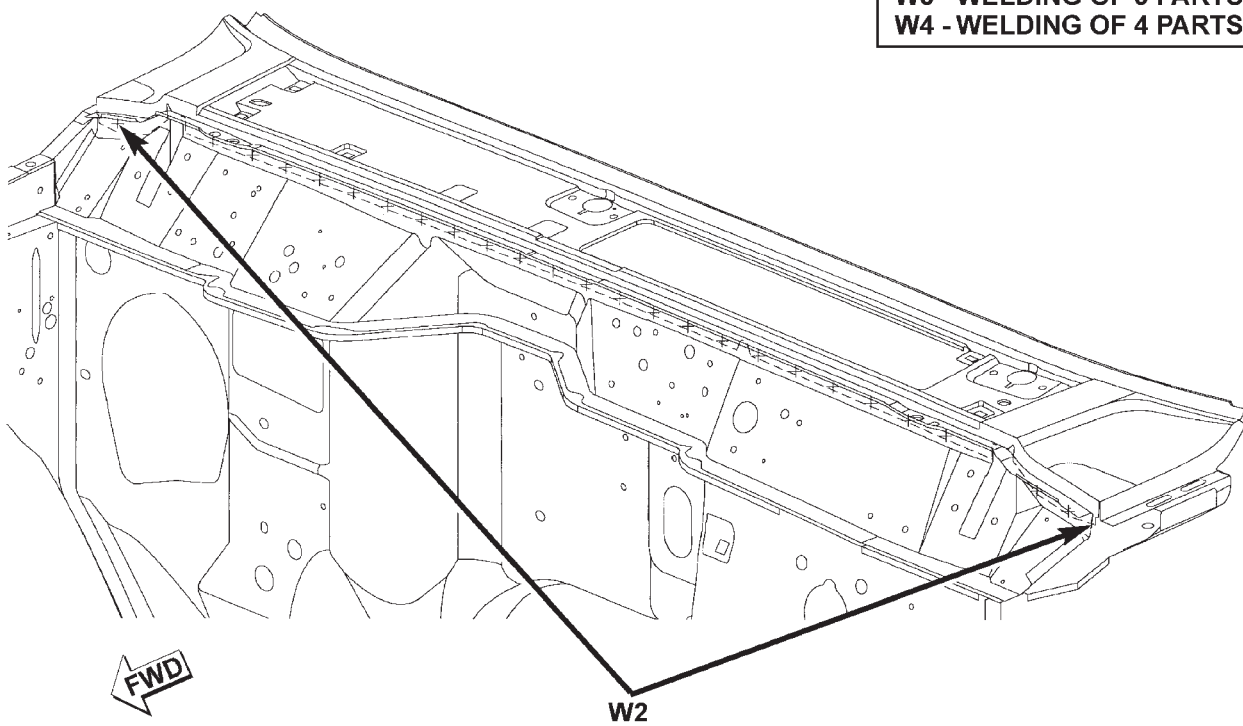

SPECIFICATIONS (Continued)

UPPER COWL

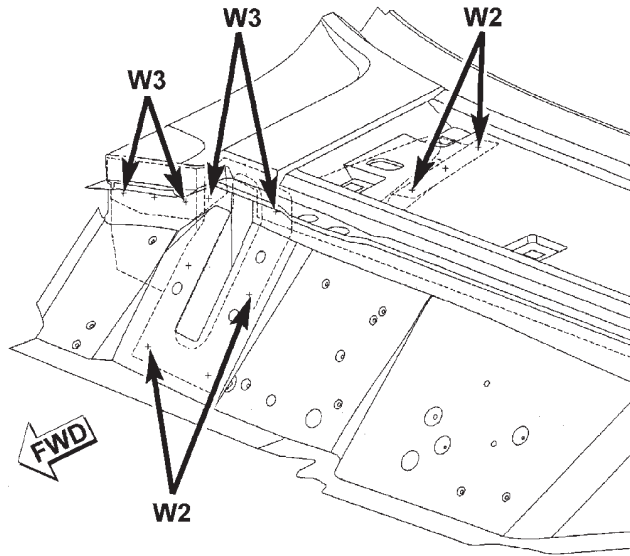

W2 - WELDING OF 2 PARTS
W3 - WELDING OF 3 PARTS
W4 - WELDING OF 4 PARTS

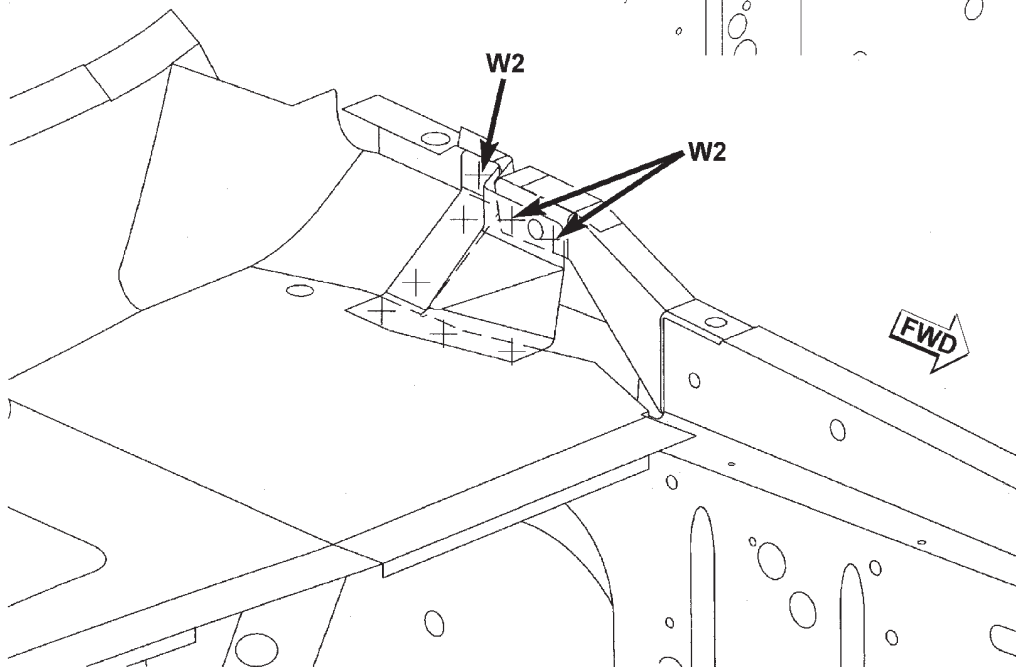
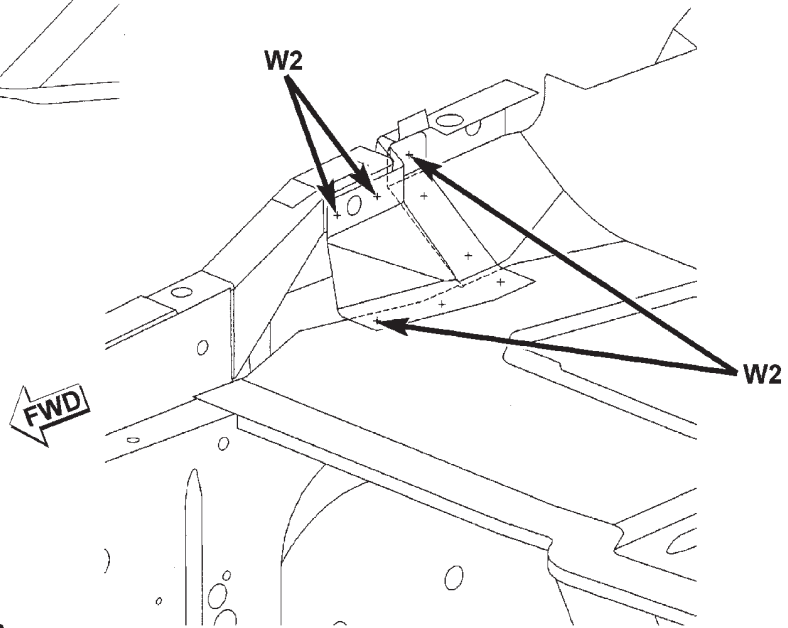

SPECIFICATIONS (Continued)

COWL

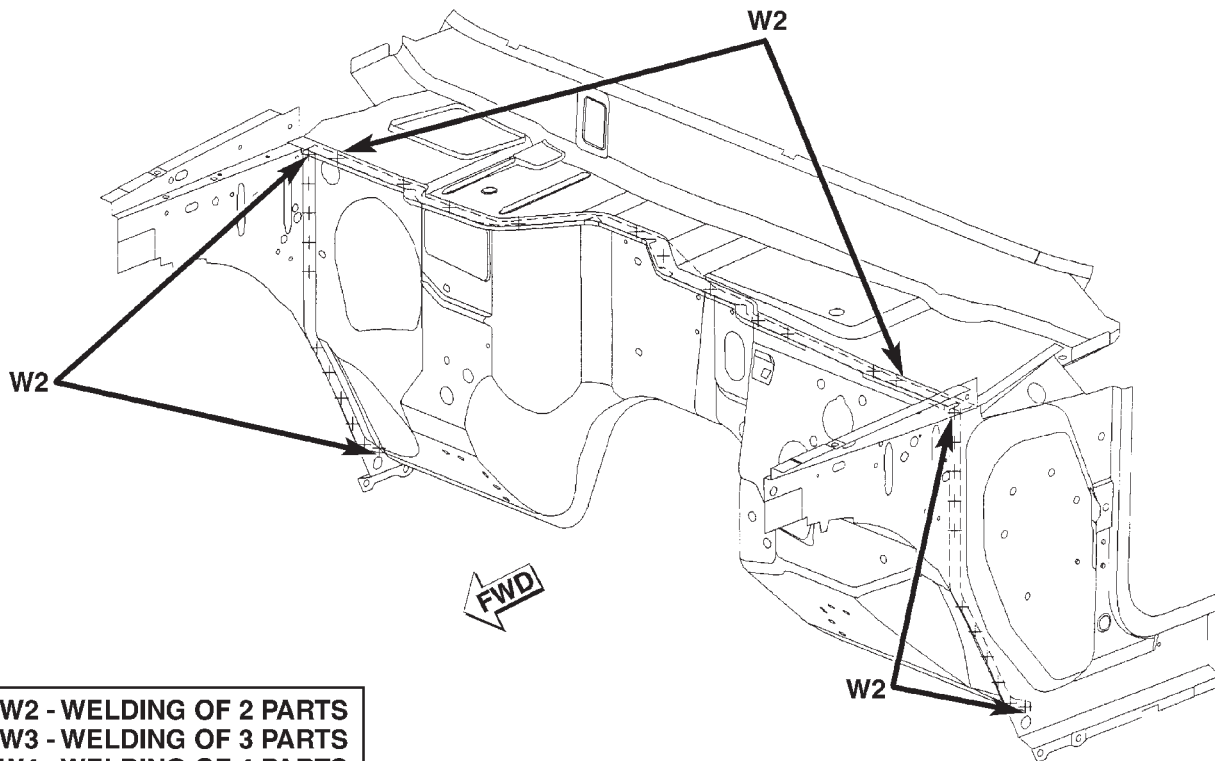
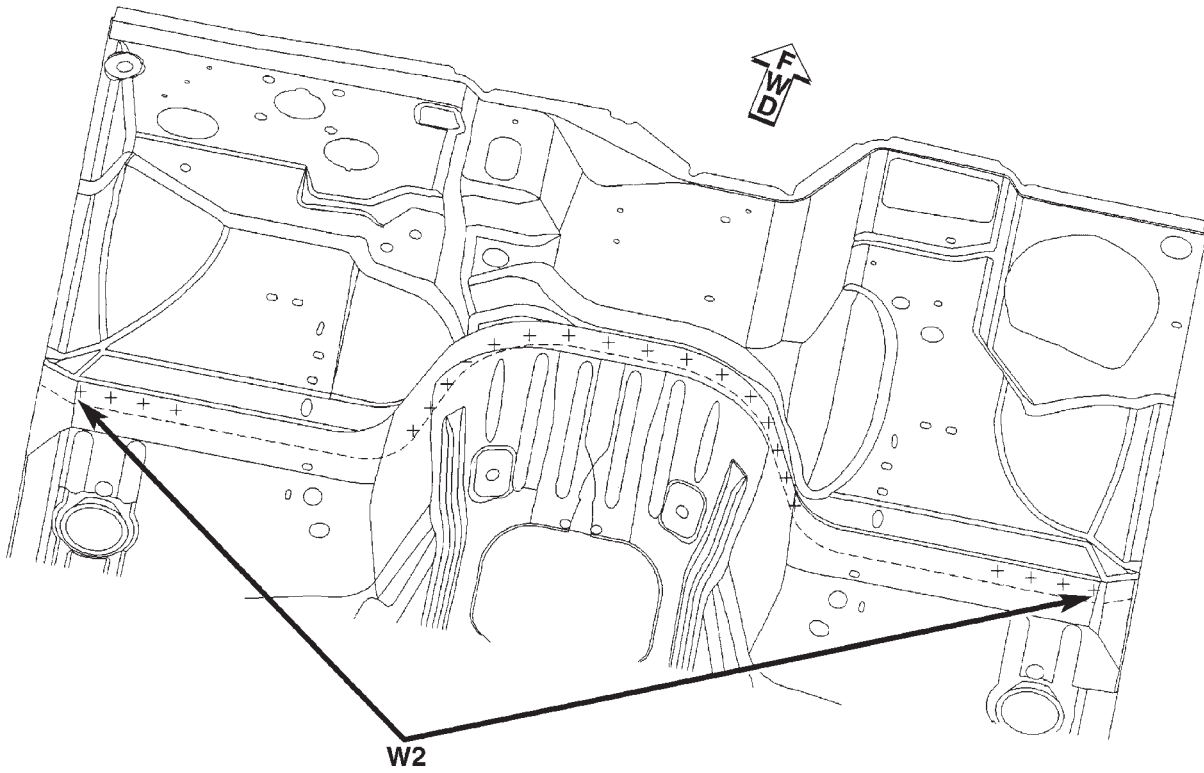

W2 - WELDING OF 2 PARTS
W3 - WELDING OF 3 PARTS
W4 - WELDING OF 4 PARTS

SPECIFICATIONS (Continued)

A—PILLAR

W2 - WELDING OF 2 PARTS
W3 - WELDING OF 3 PARTS
W4 - WELDING OF 4 PARTS

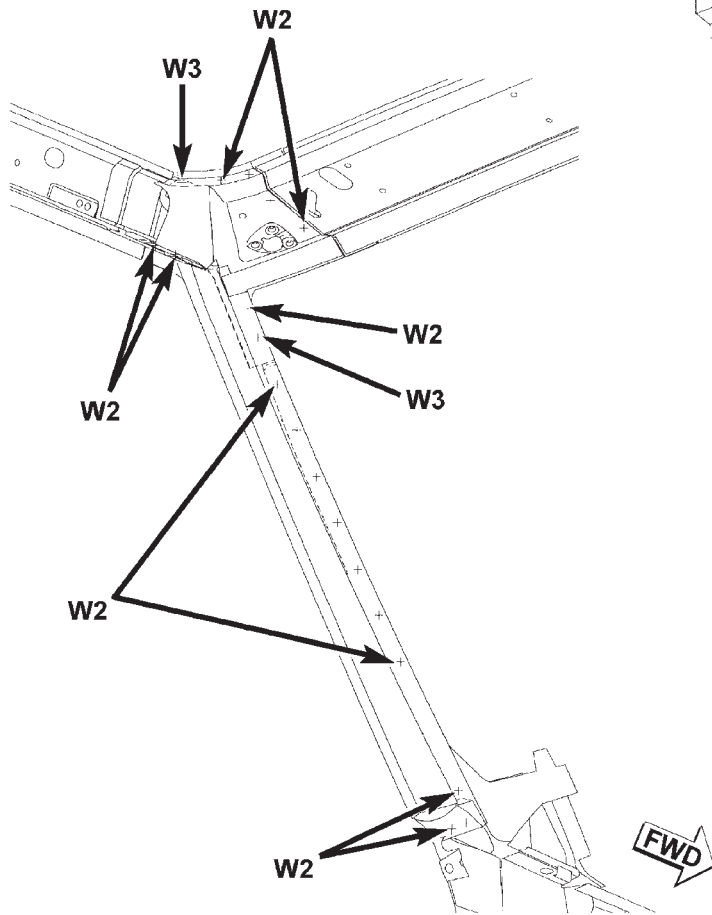
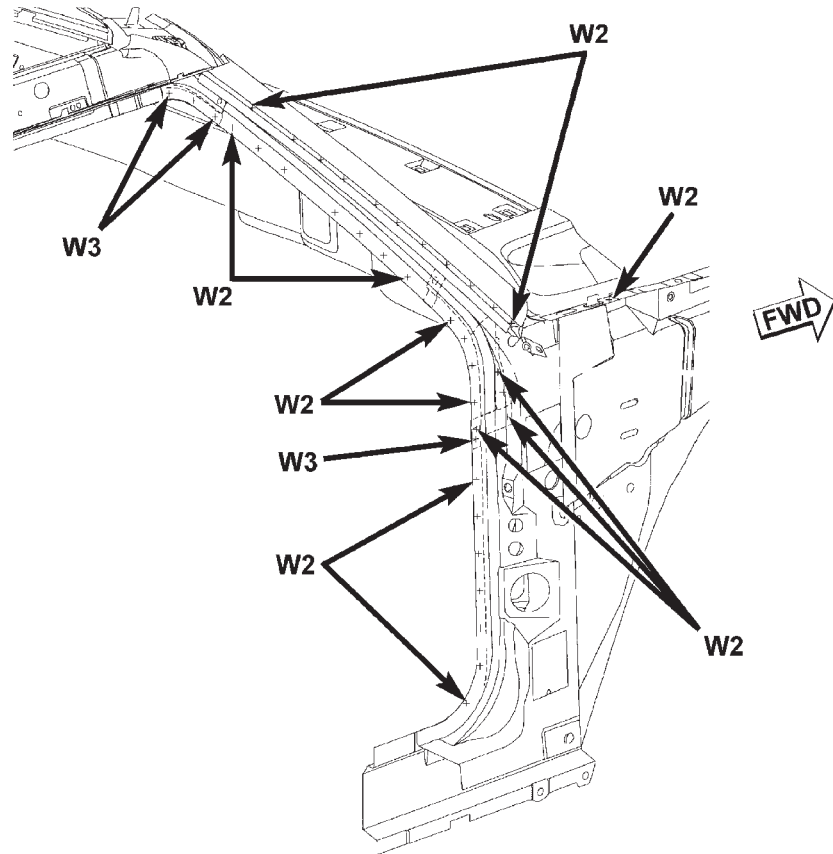

SPECIFICATIONS (Continued)

A—PILLAR

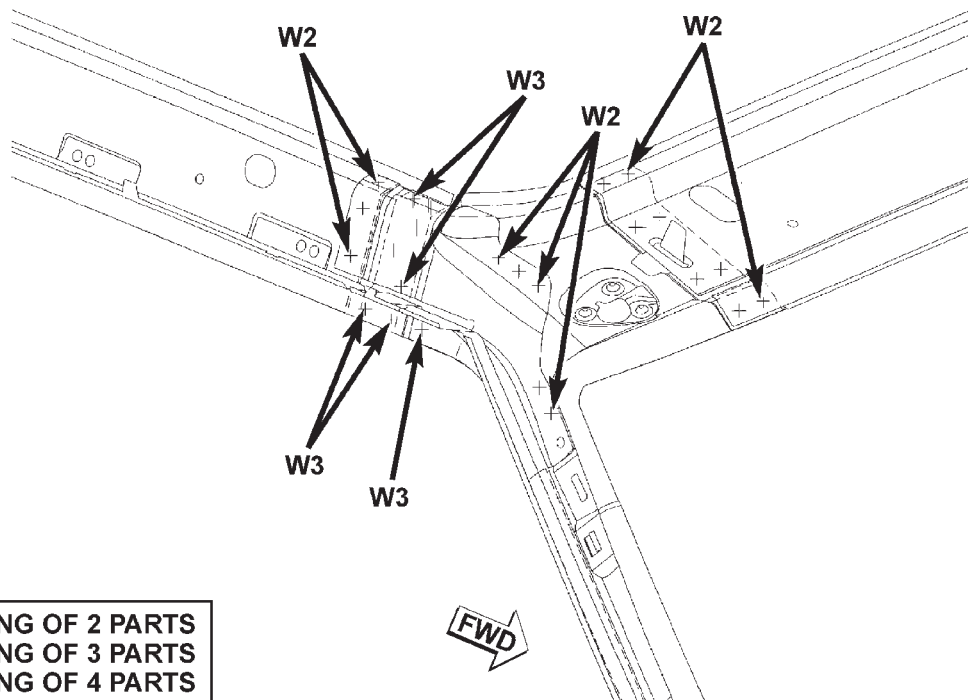
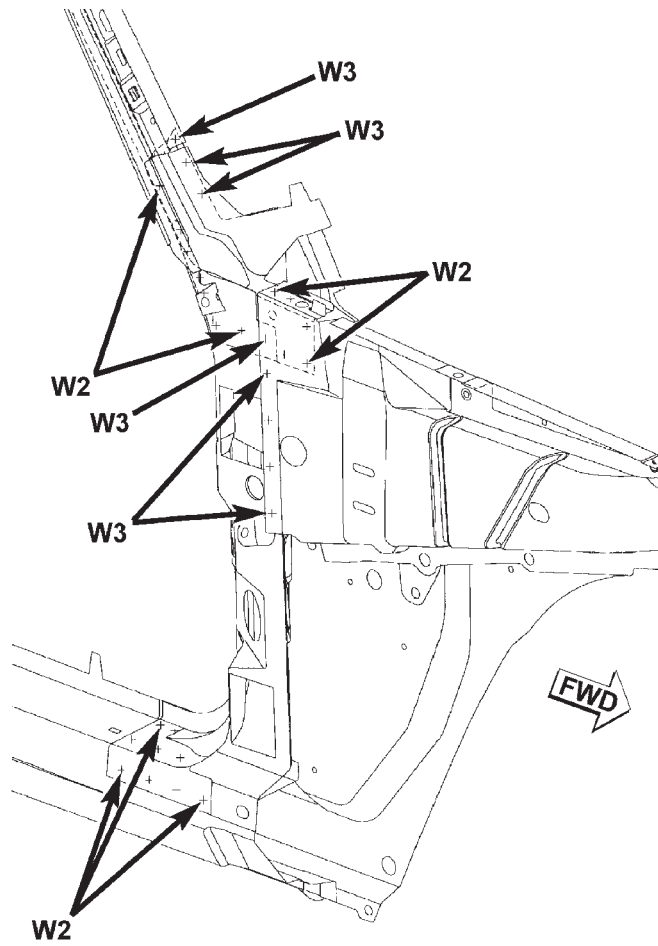

W2 - WELDING OF 2 PARTS
W3 - WELDING OF 3 PARTS
W4 - WELDING OF 4 PARTS

SPECIFICATIONS (Continued)

A—PILLAR

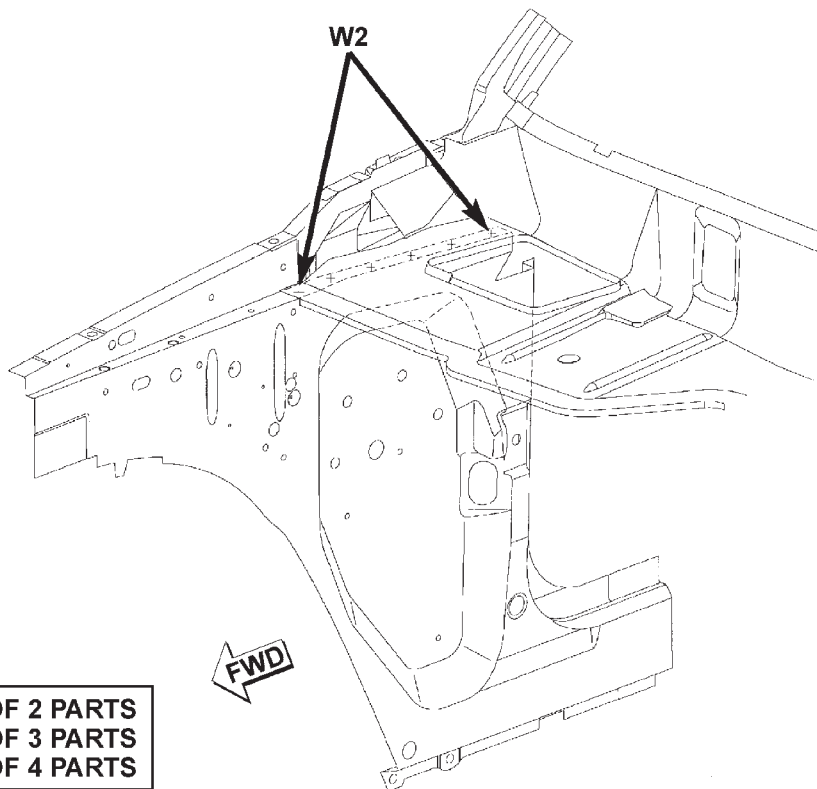
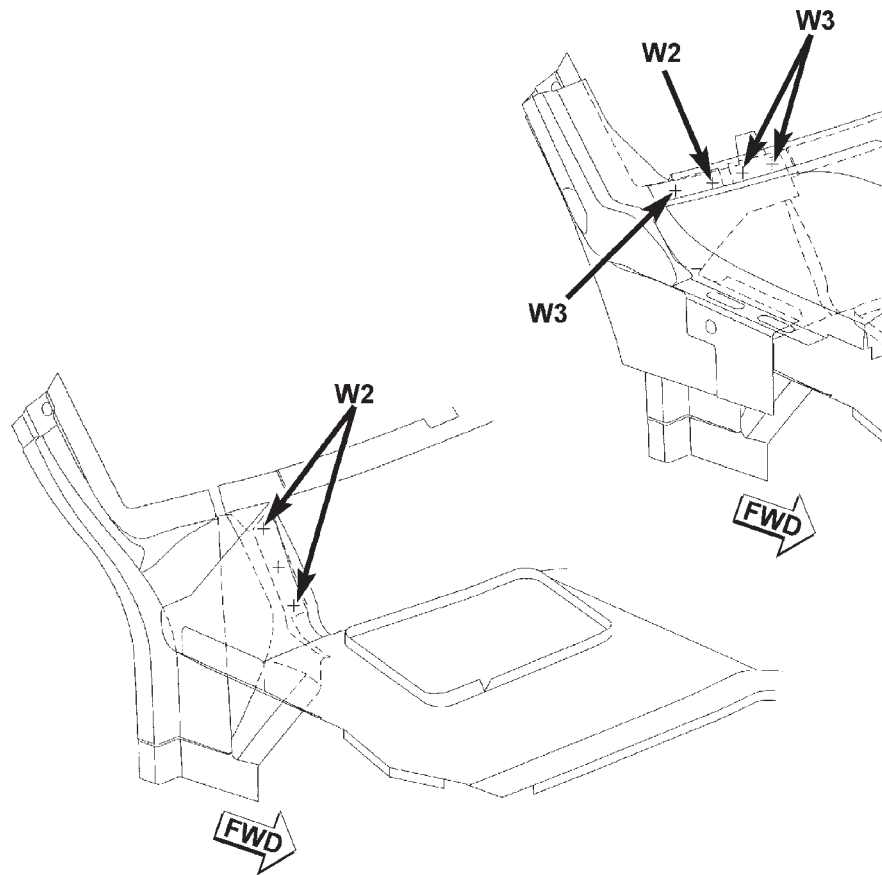

W2 - WELDING OF 2 PARTS
W3 - WELDING OF 3 PARTS
W4 - WELDING OF 4 PARTS

SPECIFICATIONS (Continued)

A—PILLAR

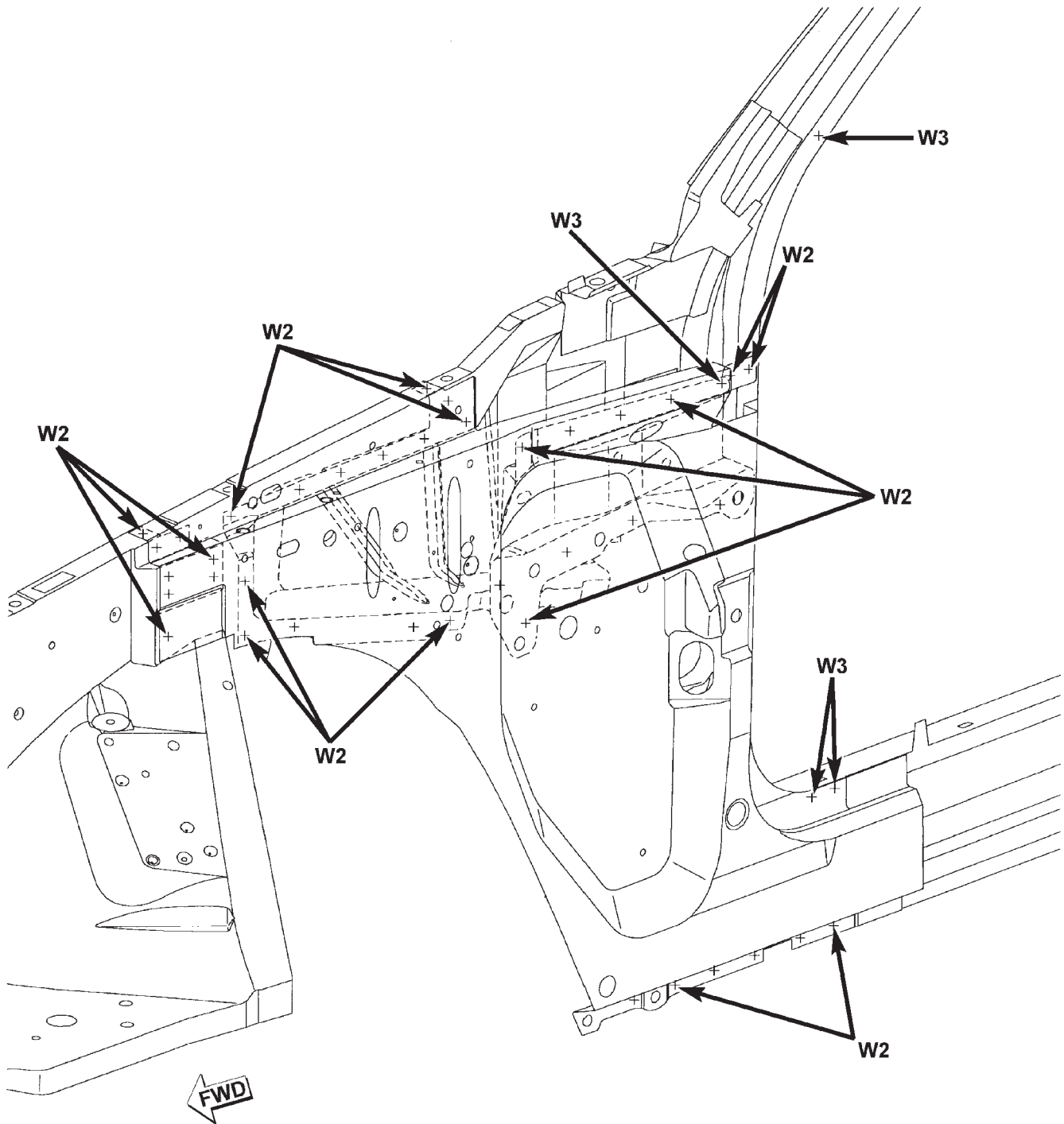

W2 - WELDING OF 2 PARTS
W3 - WELDING OF 3 PARTS
W4 - WELDING OF 4 PARTS

SPECIFICATIONS (Continued)

B—PILLAR

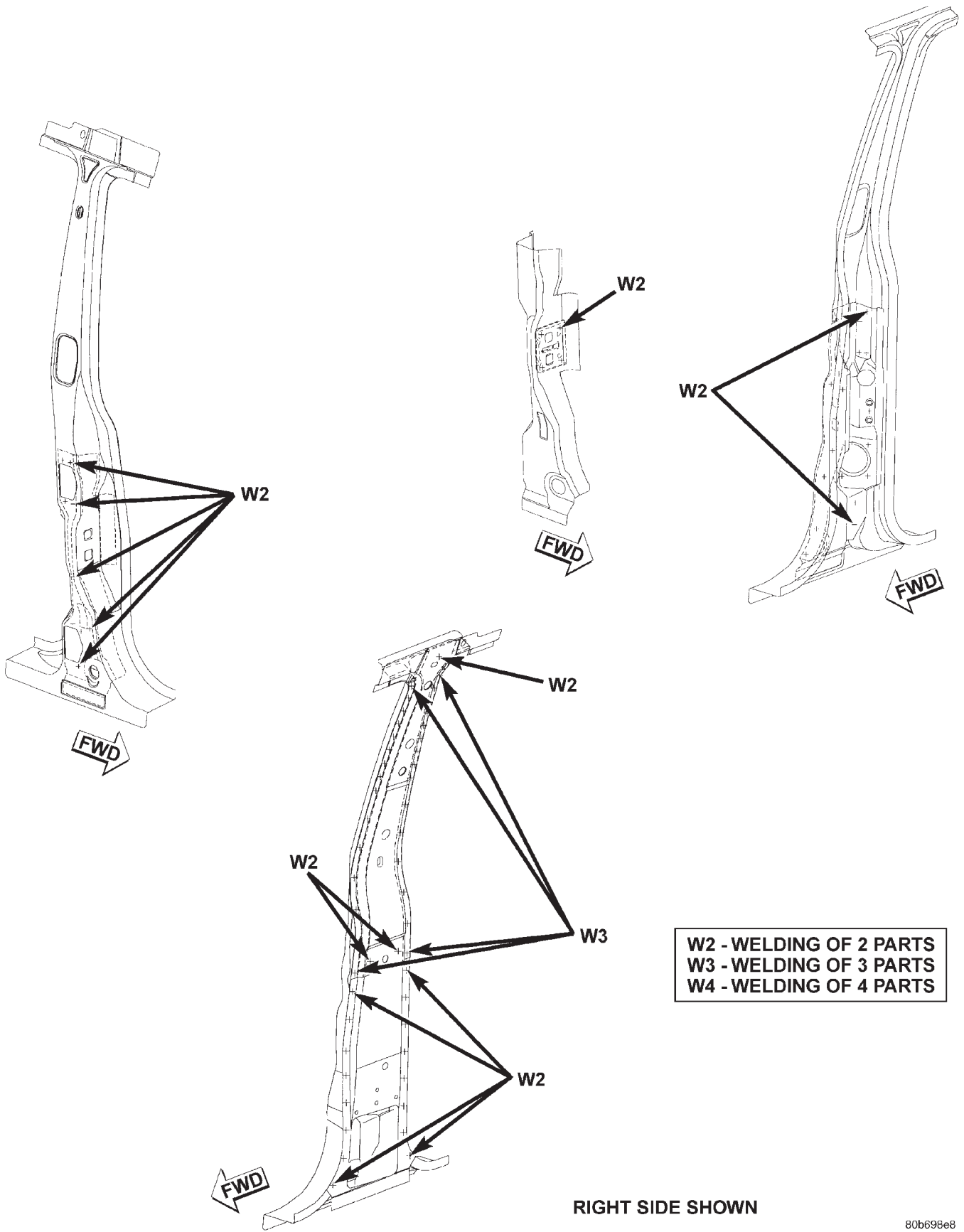

SPECIFICATIONS (Continued)

D—PILLAR

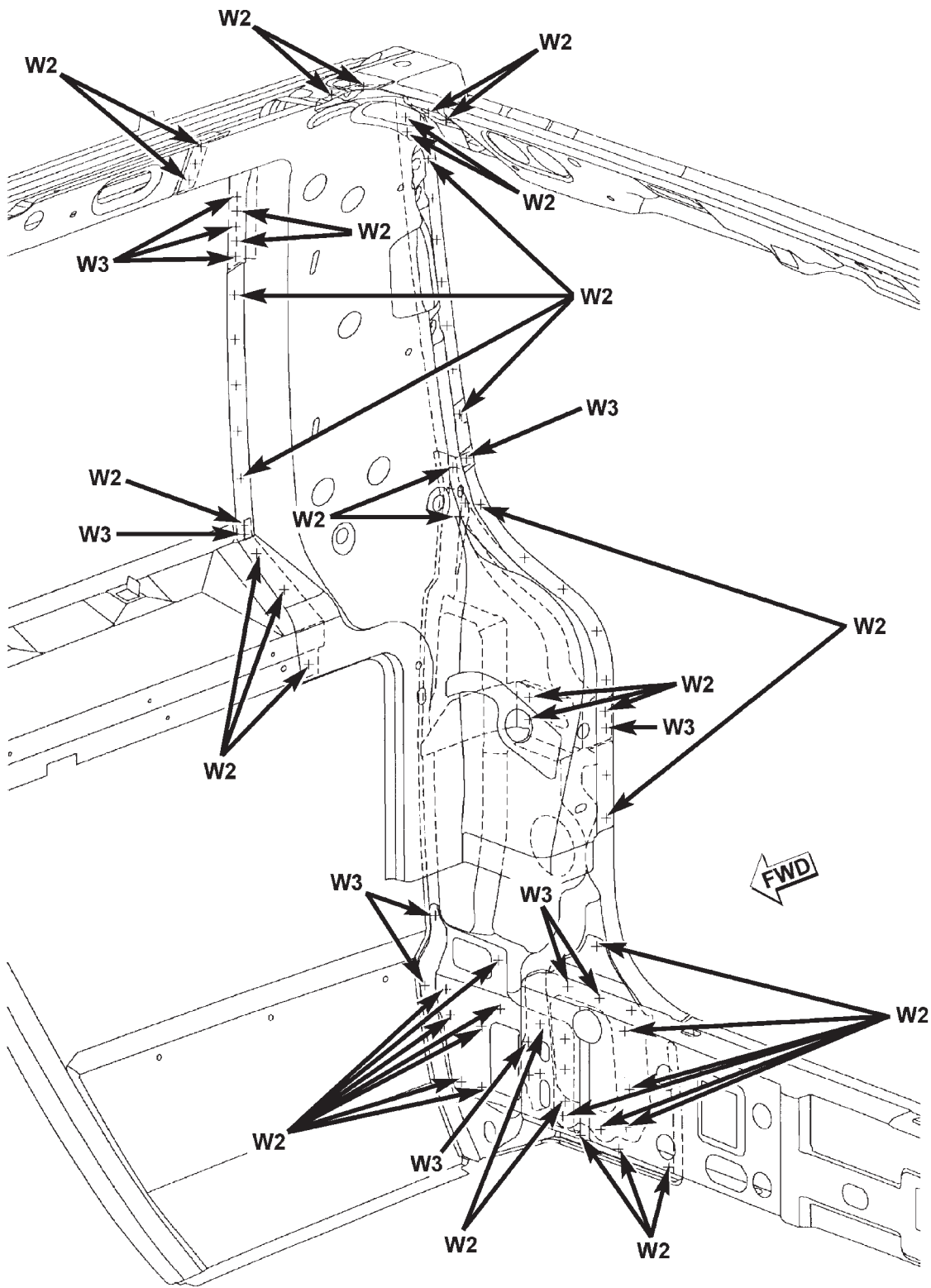

W2 - WELDING OF 2 PARTS
W3 - WELDING OF 3 PARTS
W4 - WELDING OF 4 PARTS

SPECIFICATIONS (Continued)

FUEL FILLER OPENING

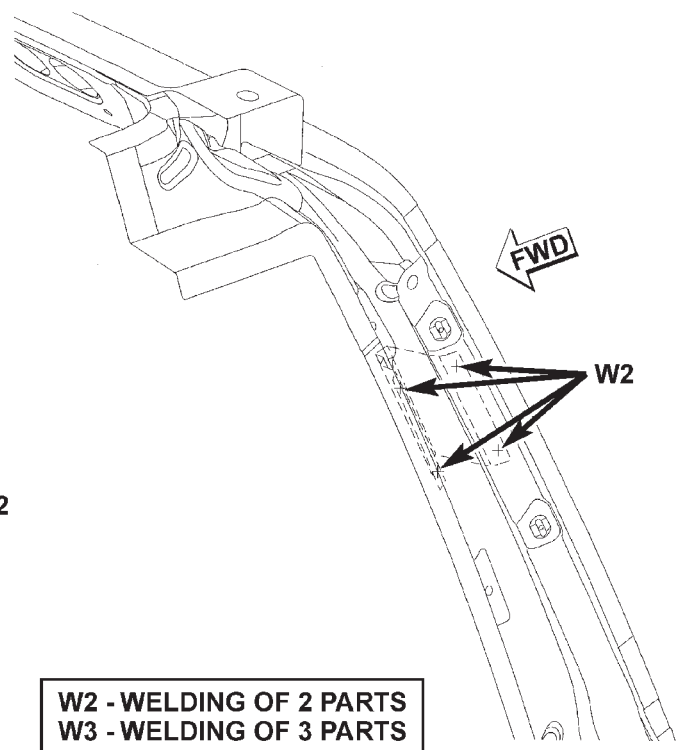
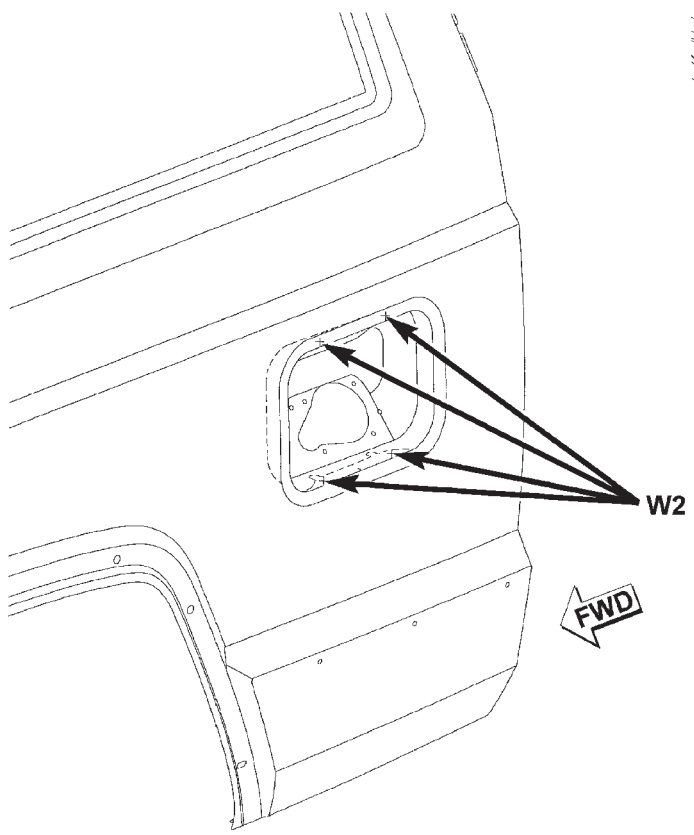

W2 - WELDING OF 2 PARTS
W3 - WELDING OF 3 PARTS
W4 - WELDING OF 4 PARTS

SPECIFICATIONS (Continued)

CARGO AREA FLOOR PAN

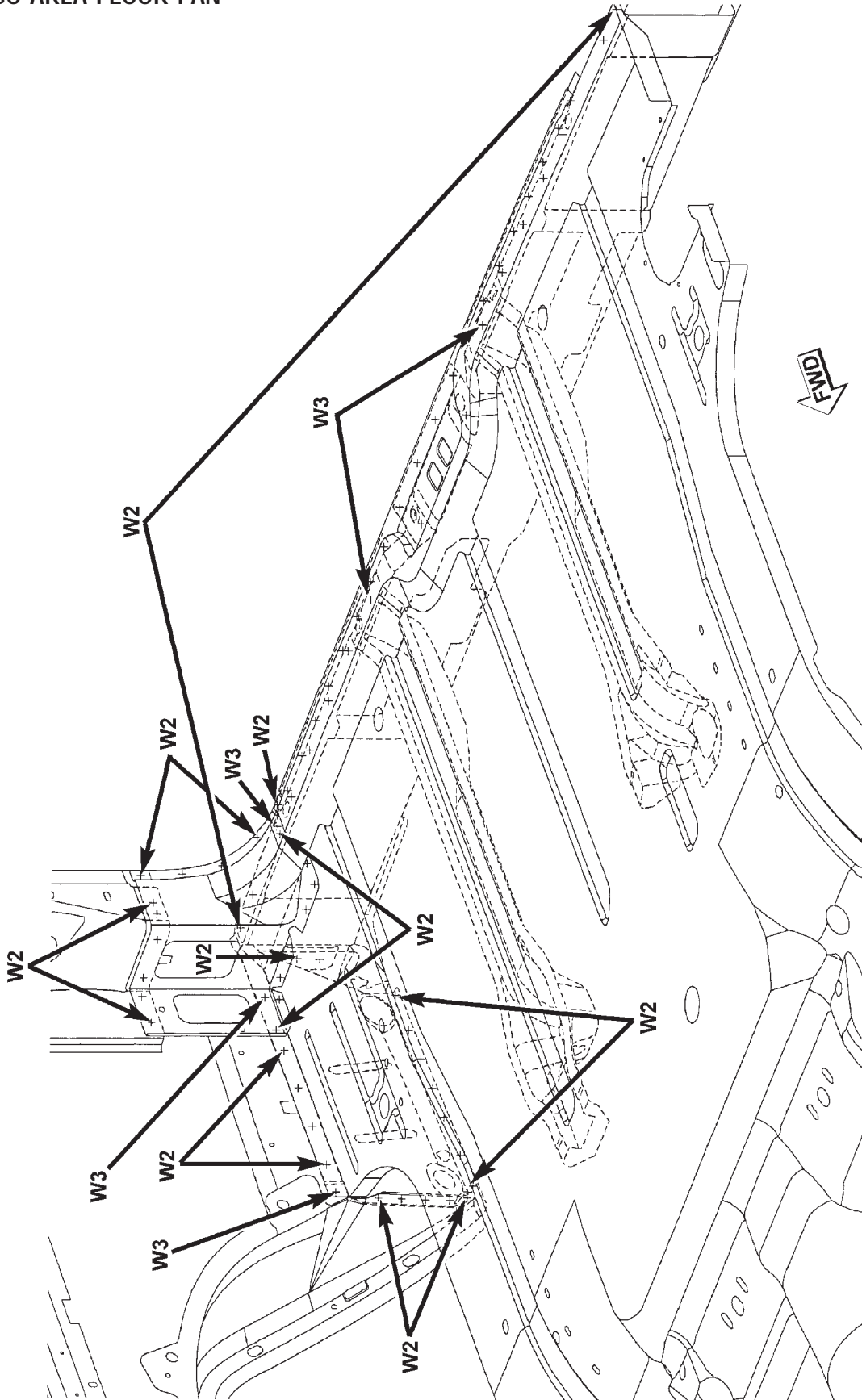

80b698eb

W2 - WELDING OF 2 PARTS
W3 - WELDING OF 3 PARTS
W4 - WELDING OF 4 PARTS

SPECIFICATIONS (Continued)

ROOF AND D—PILLAR

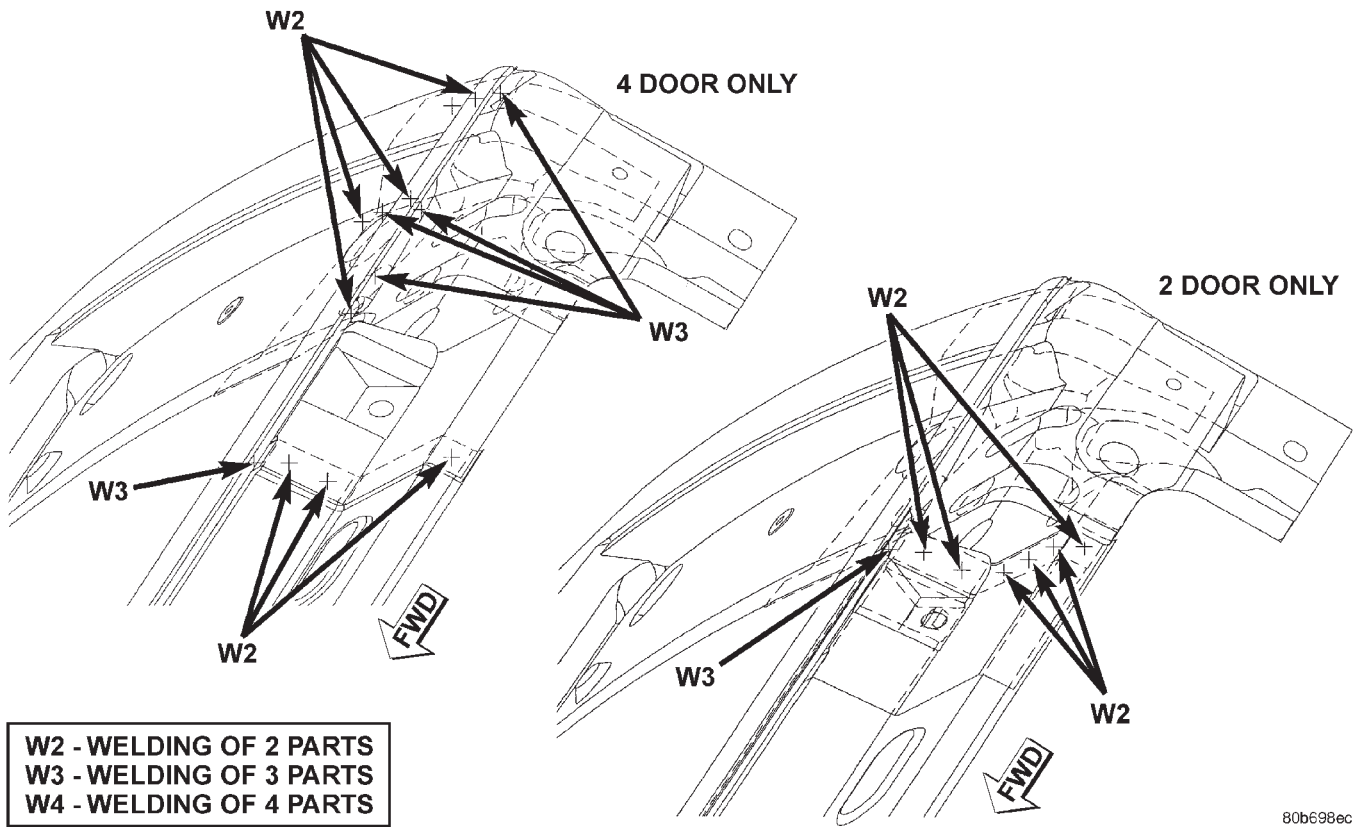

SPECIFICATIONS (Continued)

LIFTGATE OPENING

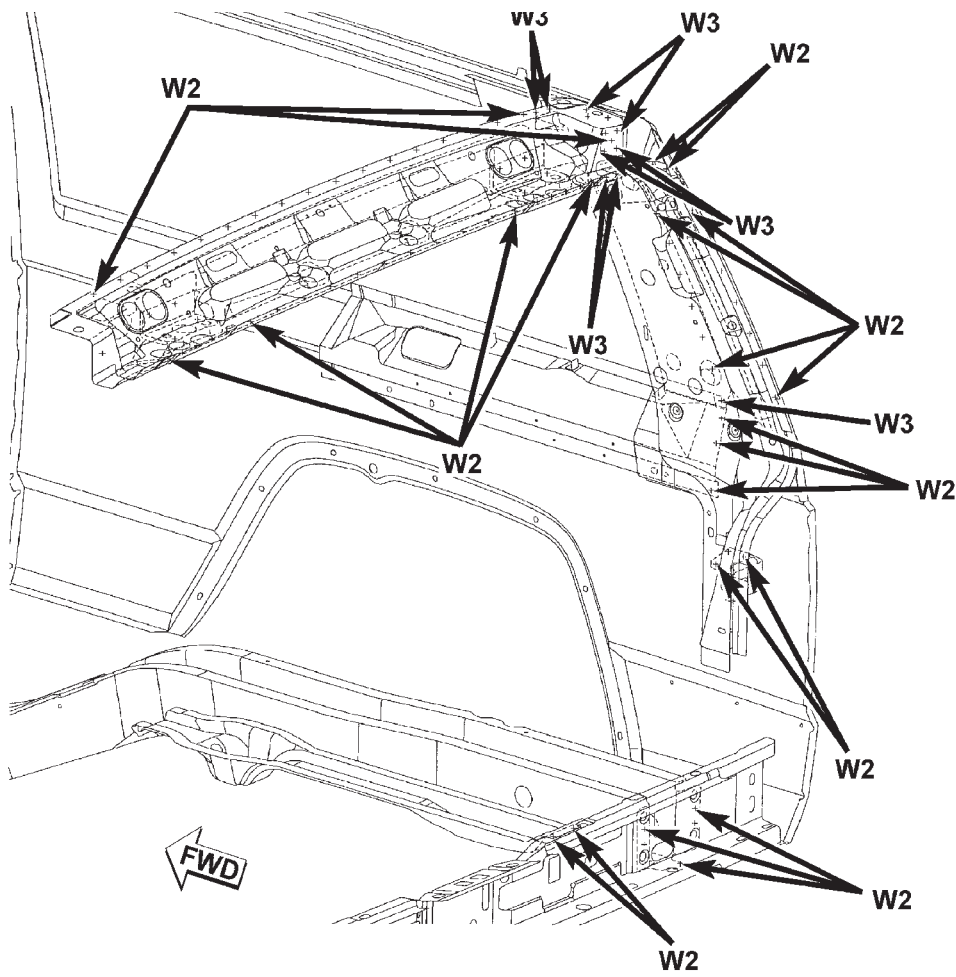

W2 - WELDING OF 2 PARTS
W3 - WELDING OF 3 PARTS
W4 - WELDING OF 4 PARTS

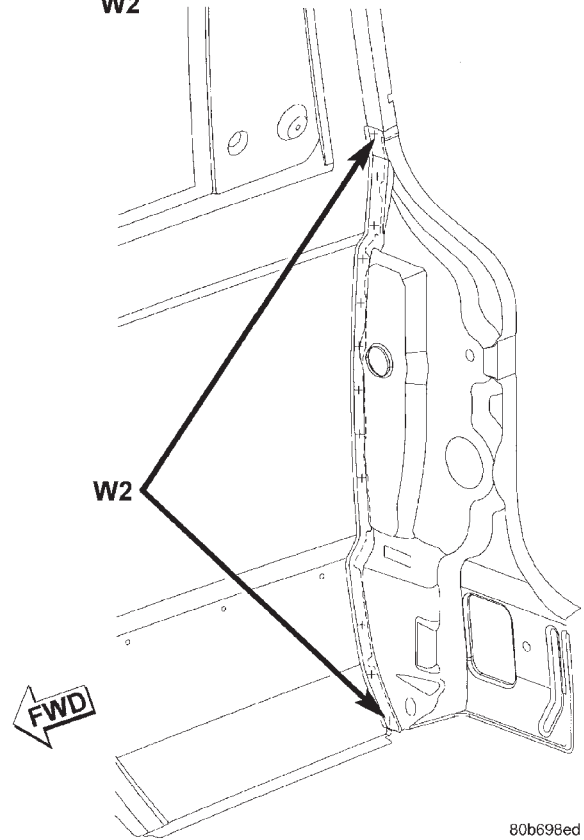

SPECIFICATIONS (Continued)

ROOF

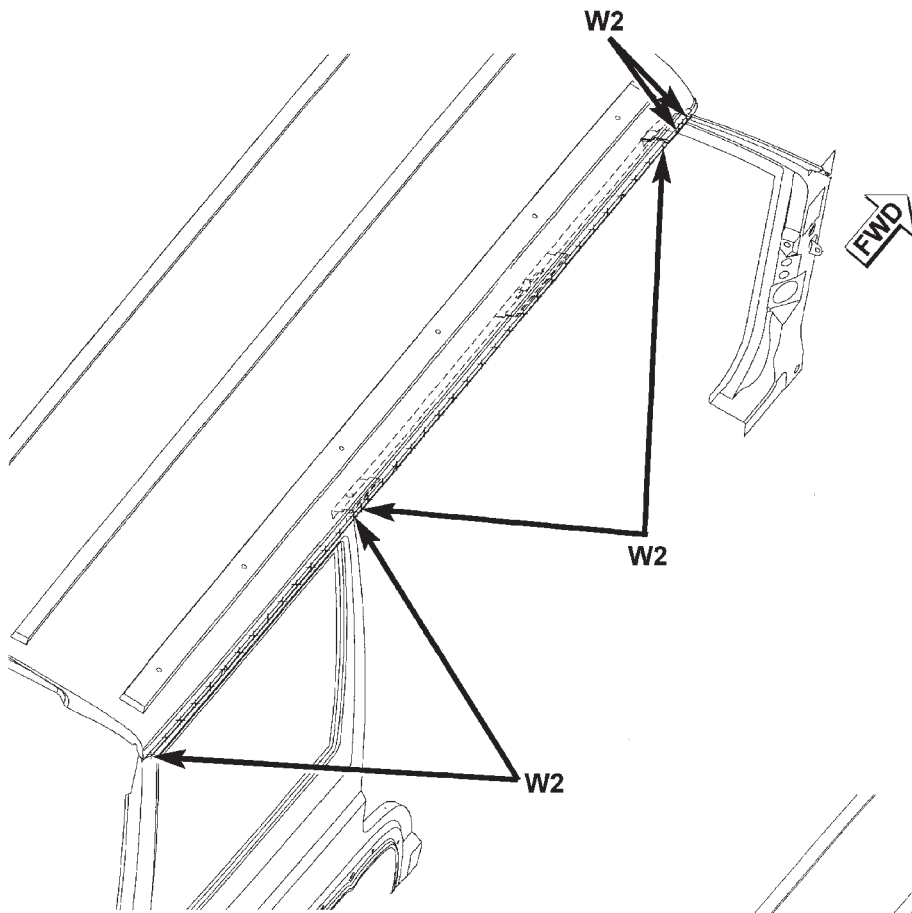

4 DOOR

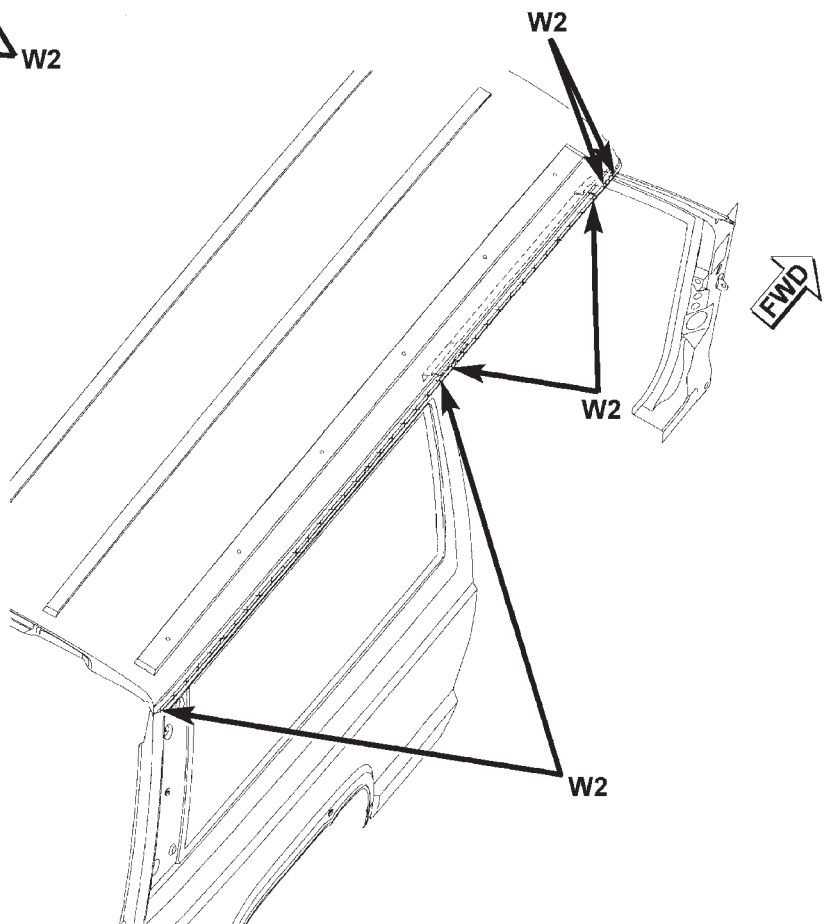

2 DOOR

W2 - WELDING OF 2 PARTS
W3 - WELDING OF 3 PARTS
W4 - WELDING OF 4 PARTS

SPECIFICATIONS (Continued)

ROOF

W2 - WELDING OF 2 PARTS
W3 - WELDING OF 3 PARTS
W4 - WELDING OF 4 PARTS

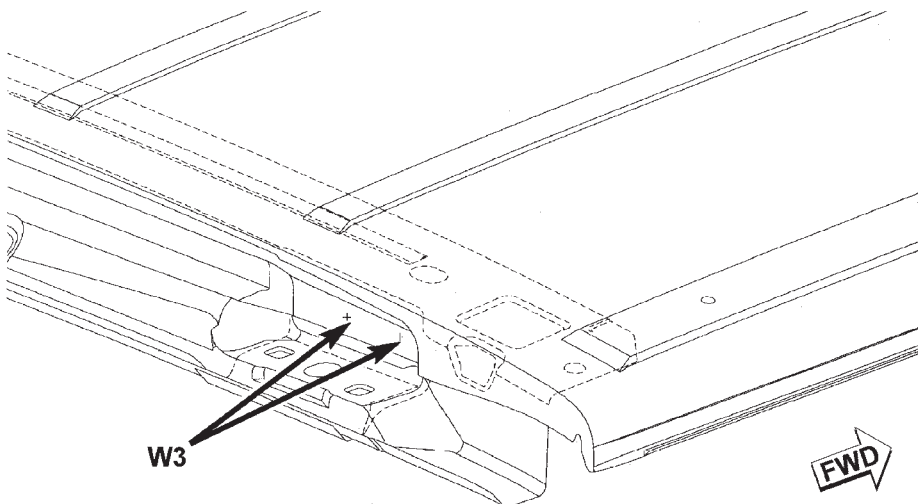
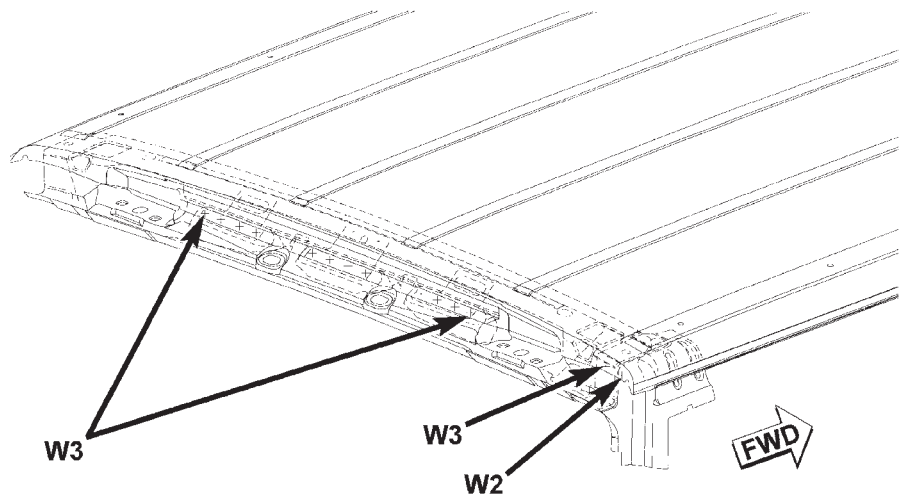
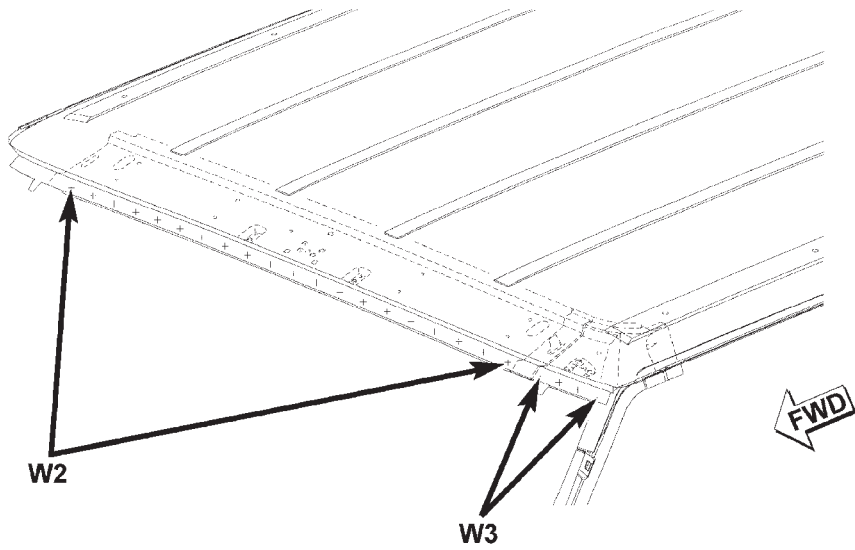

SPECIFICATIONS (Continued)

FRAME RAIL

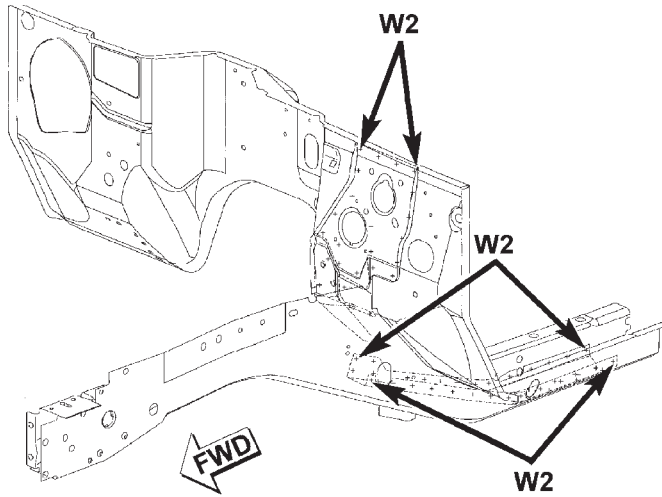

W2 - WELDING OF 2 PARTS
W3 - WELDING OF 3 PARTS
W4 - WELDING OF 4 PARTS

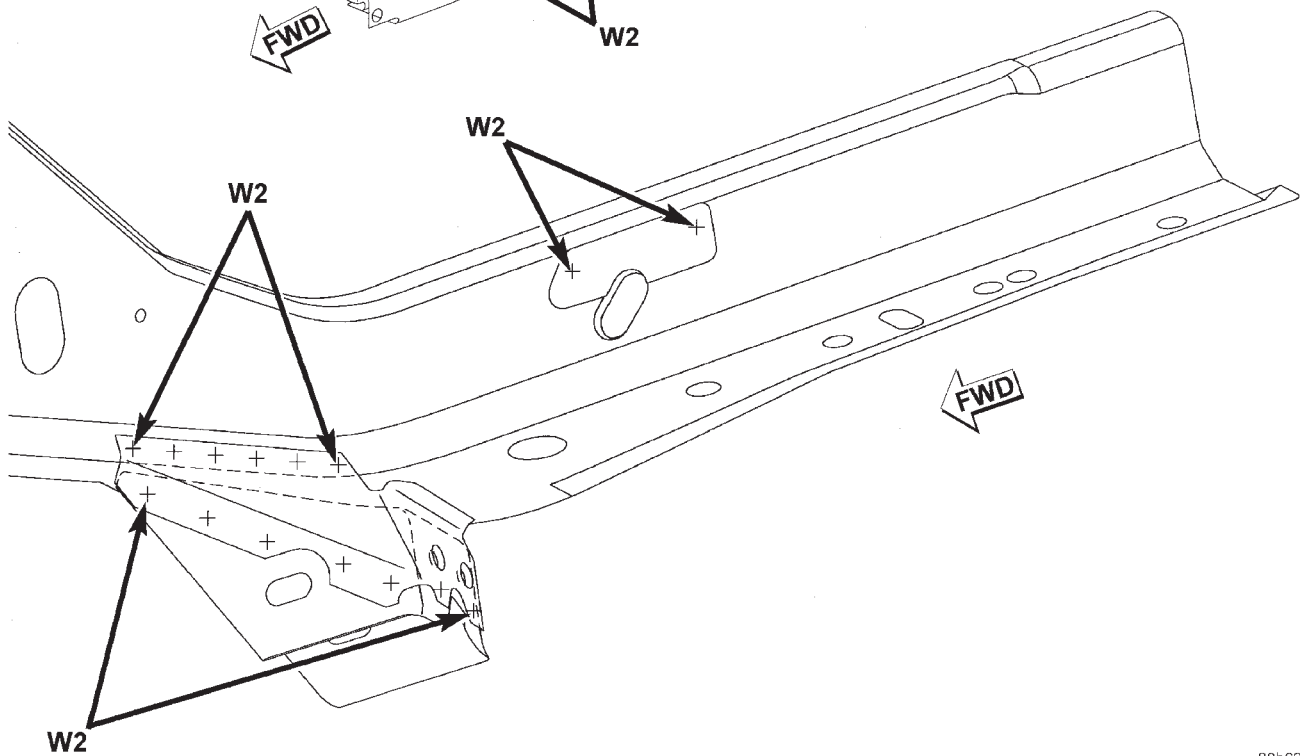
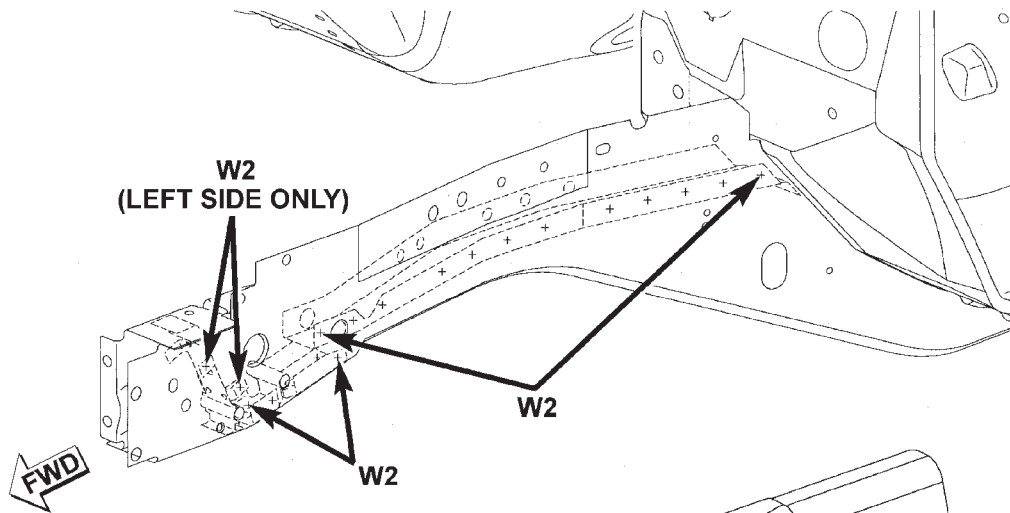

SPECIFICATIONS (Continued)

FRAME RAIL

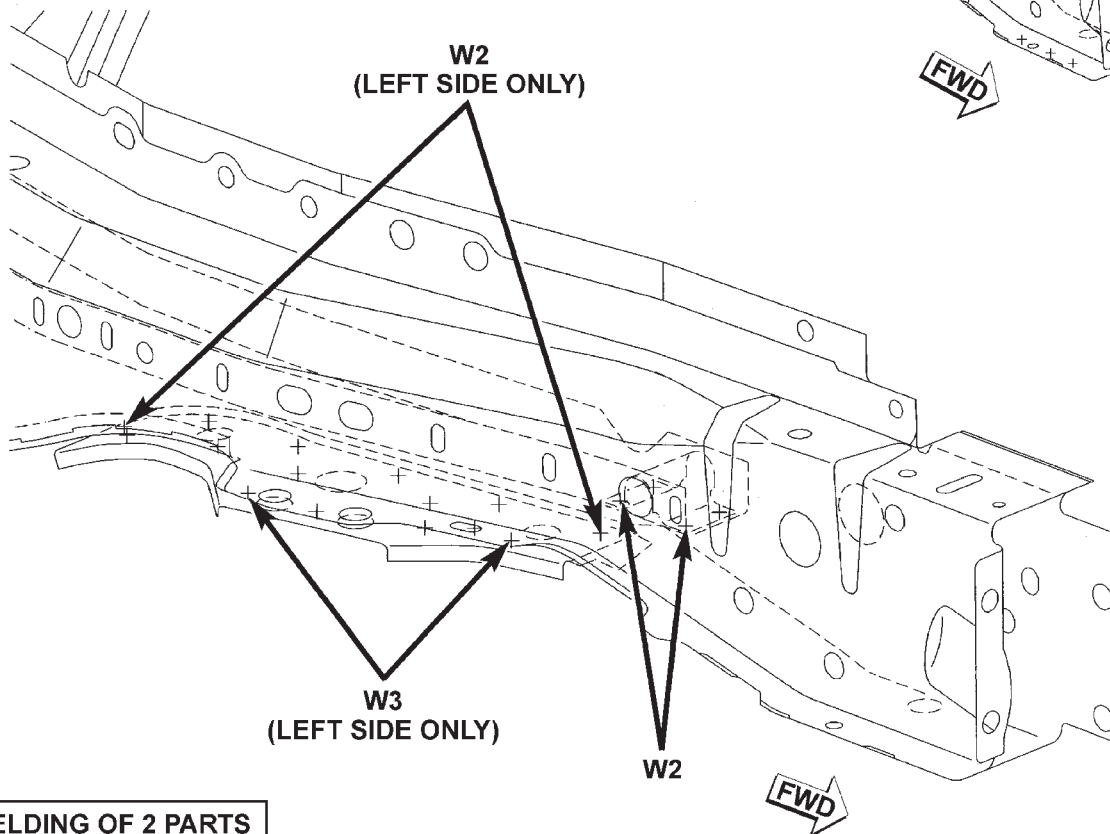
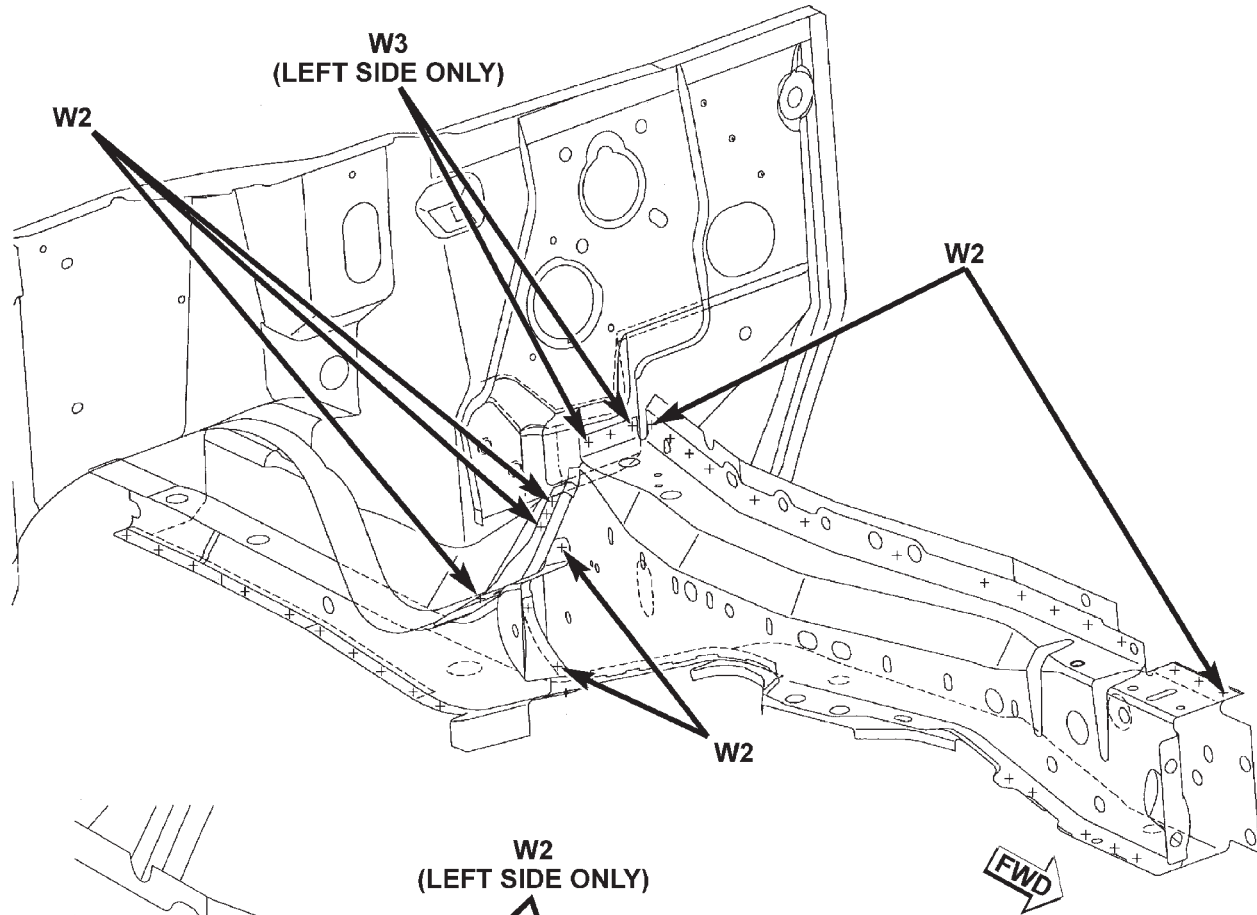

W2 - WELDING OF 2 PARTS
W3 - WELDING OF 3 PARTS
W4 - WELDING OF 4 PARTS

SPECIFICATIONS (Continued)

FRAME RAIL

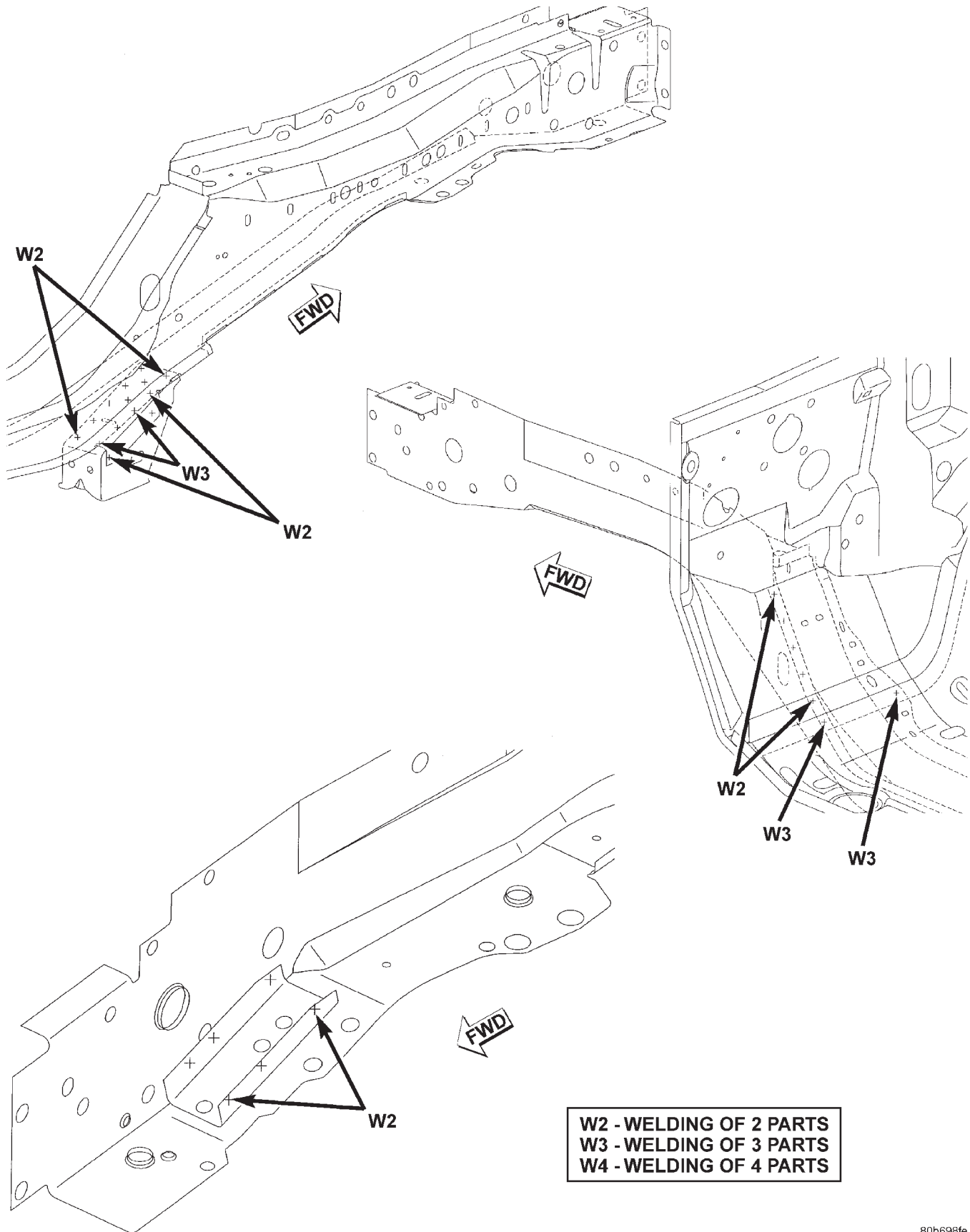

W2 - WELDING OF 2 PARTS
W3 - WELDING OF 3 PARTS
W4 - WELDING OF 4 PARTS

SPECIFICATIONS (Continued)

FRAME RAIL

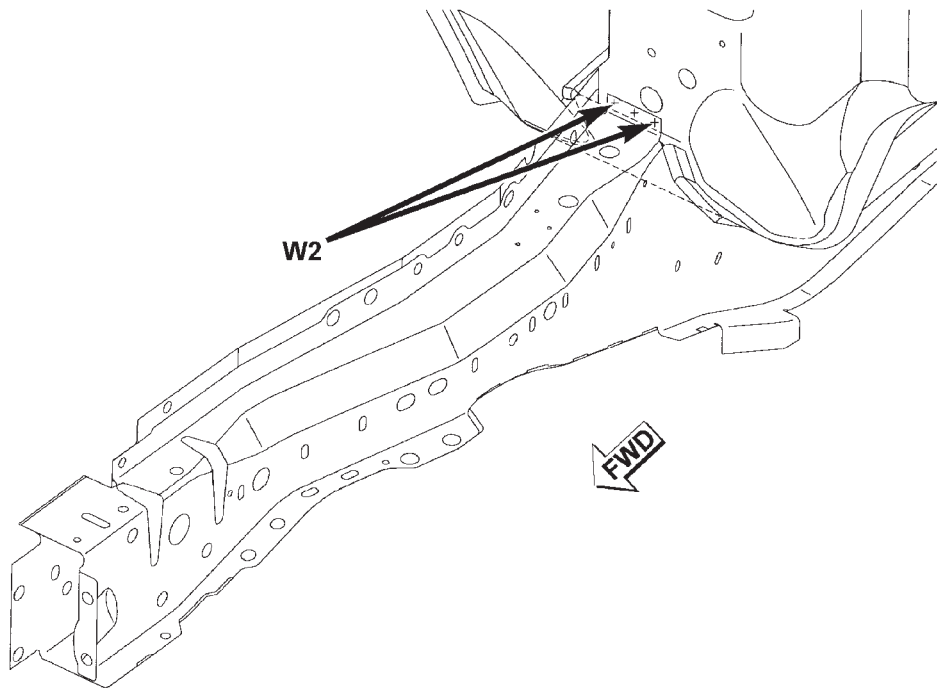
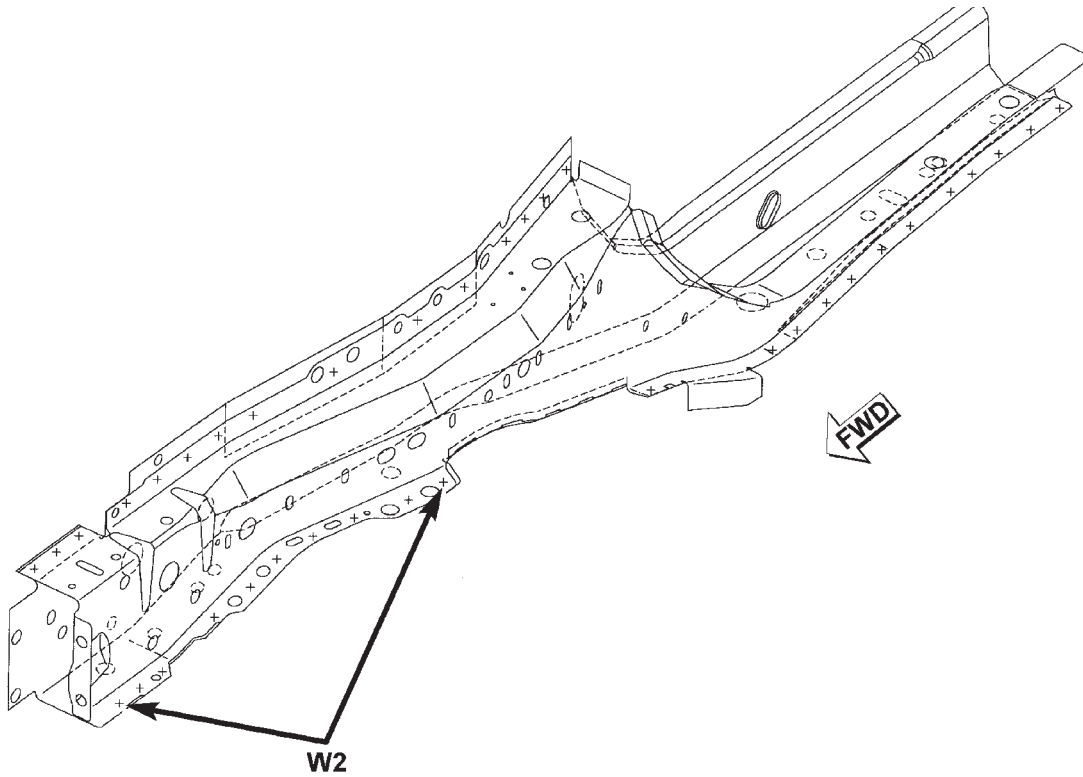

W2 - WELDING OF 2 PARTS
W3 - WELDING OF 3 PARTS
W4 - WELDING OF 4 PARTS

SPECIFICATIONS (Continued)

REINFORCEMENT

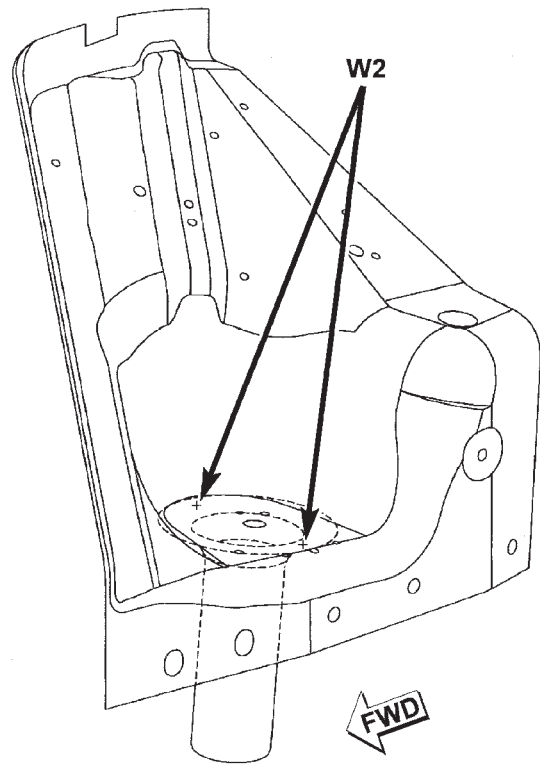

W2 - WELDING OF 2 PARTS
W3 - WELDING OF 3 PARTS
W4 - WELDING OF 4 PARTS

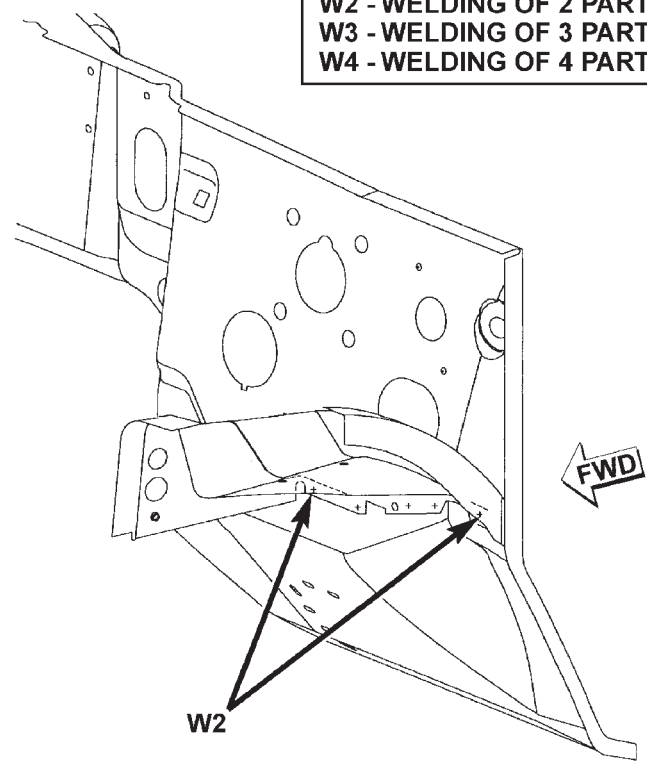

80b69900

SPECIFICATIONS (Continued)

FRONT INNER FENDER

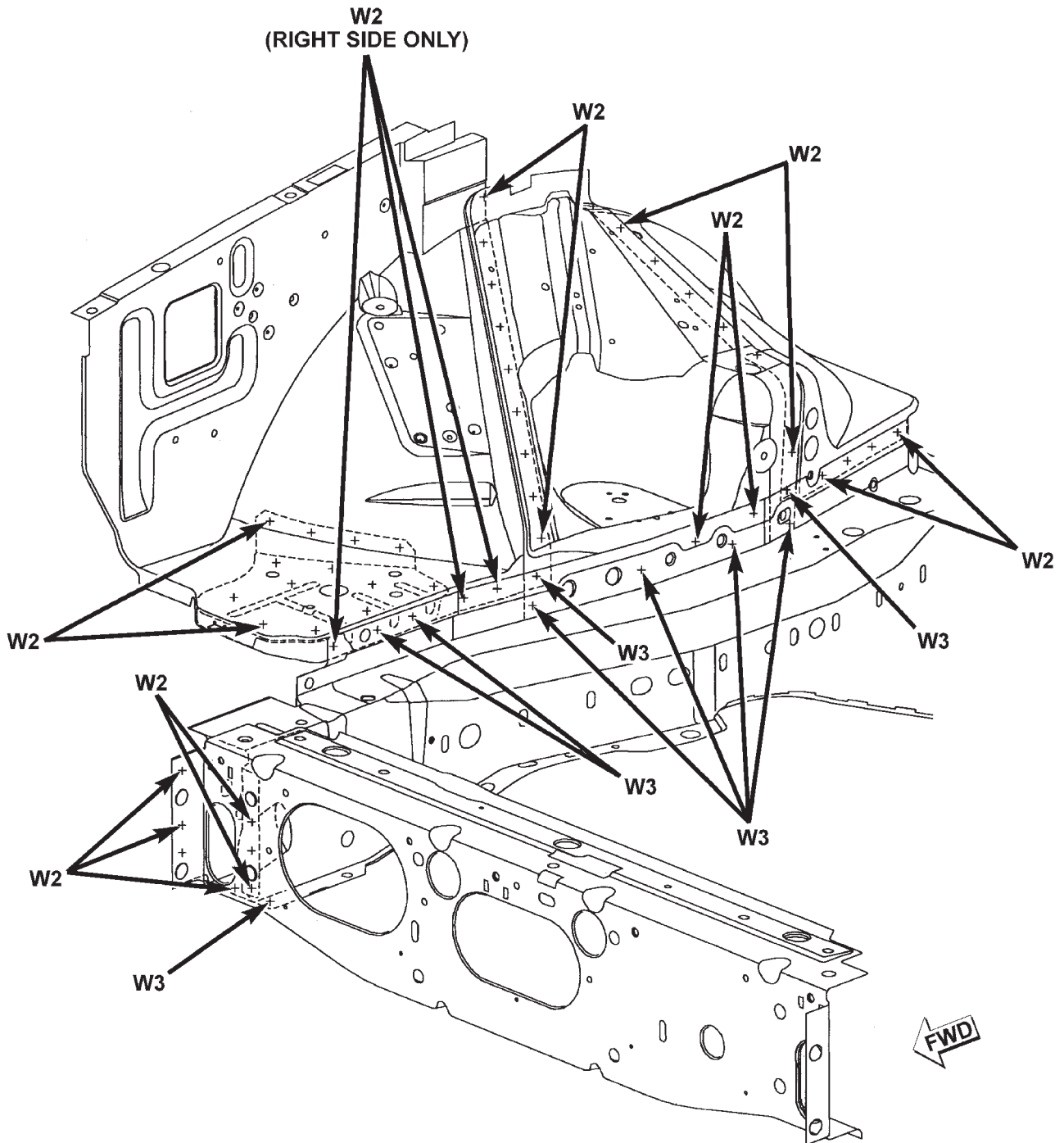

W2 - WELDING OF 2 PARTS
W3 - WELDING OF 3 PARTS
W4 - WELDING OF 4 PARTS

SPECIFICATIONS (Continued)

FRONT INNER FENDER AND RADIATOR CLOSURE PANEL

W2 - WELDING OF 2 PARTS
W3 - WELDING OF 3 PARTS
W4 - WELDING OF 4 PARTS

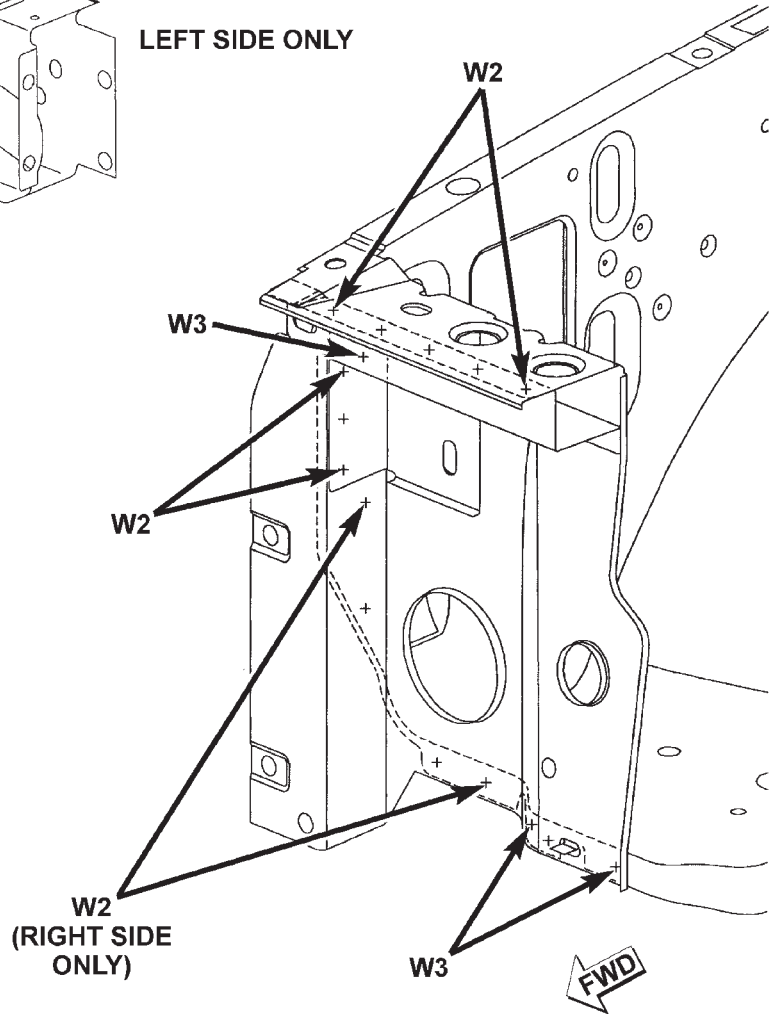
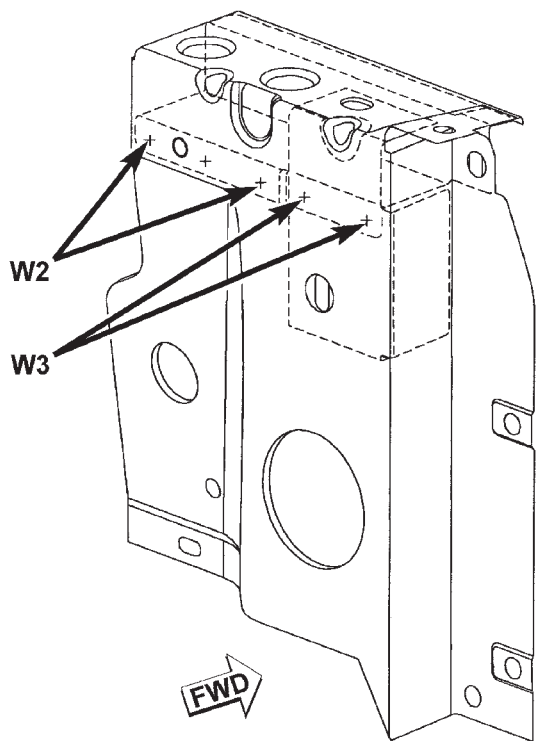
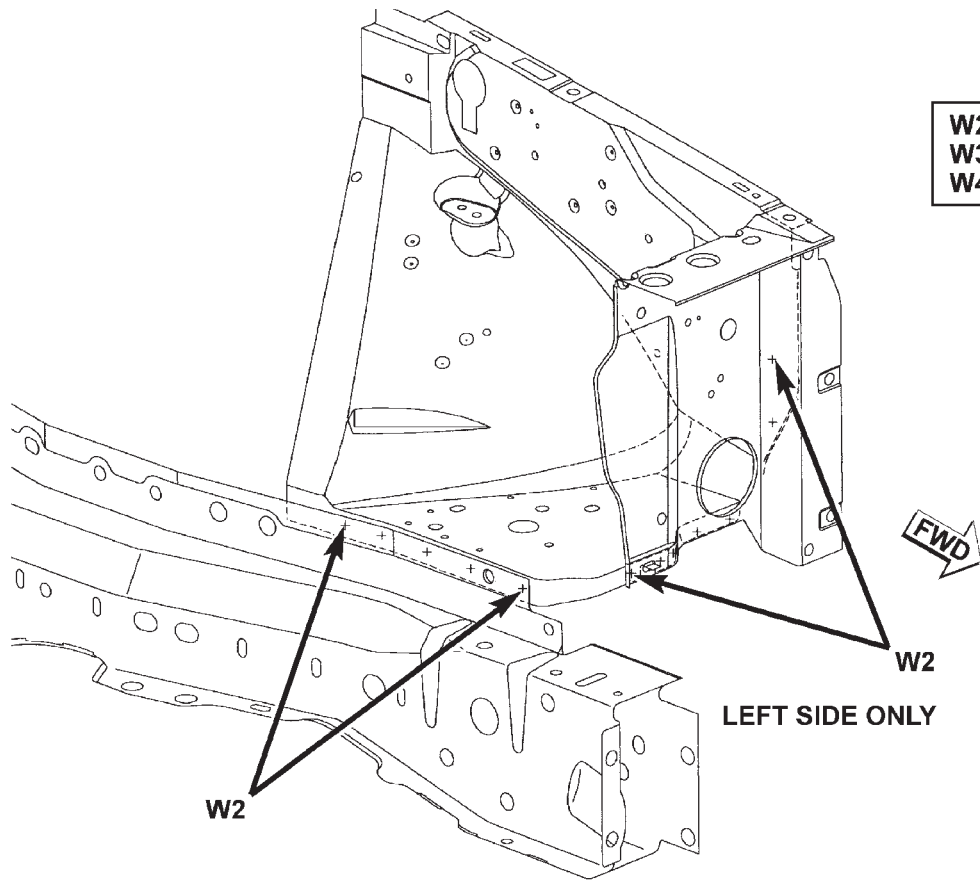

SPECIFICATIONS (Continued)

REINFORCEMENT

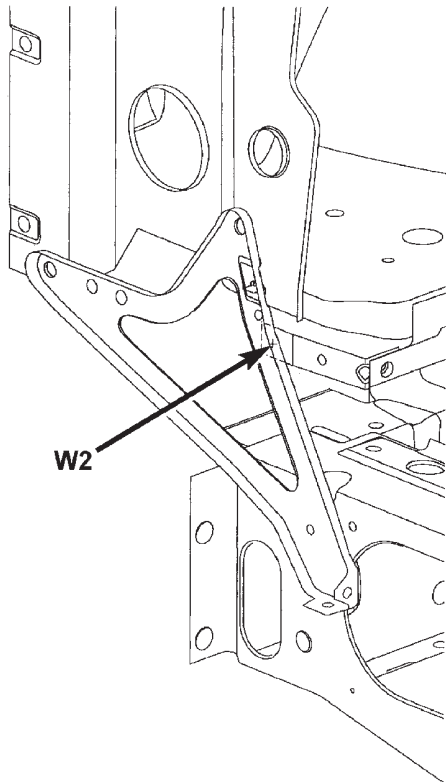

W2 - WELDING OF 2 PARTS
W3 - WELDING OF 3 PARTS
W4 - WELDING OF 4 PARTS

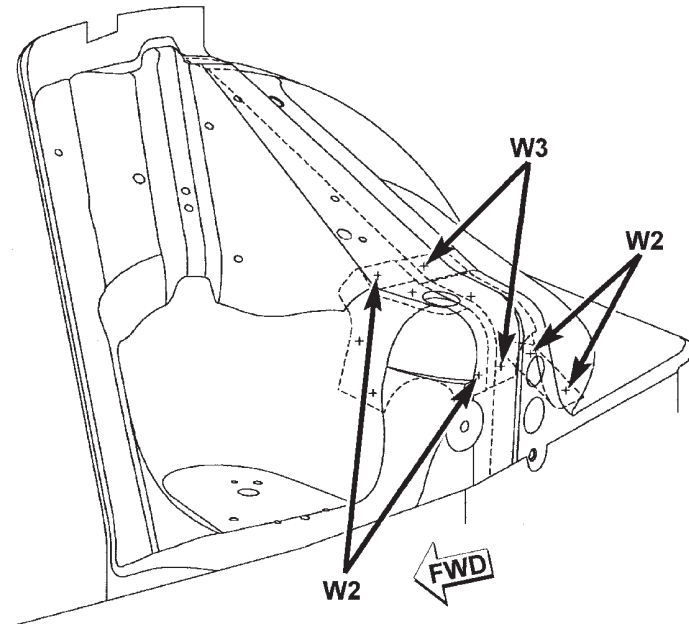

80b69903

FRONT FENDER

W2 - WELDING OF 2 PARTS
W3 - WELDING OF 3 PARTS
W4 - WELDING OF 4 PARTS

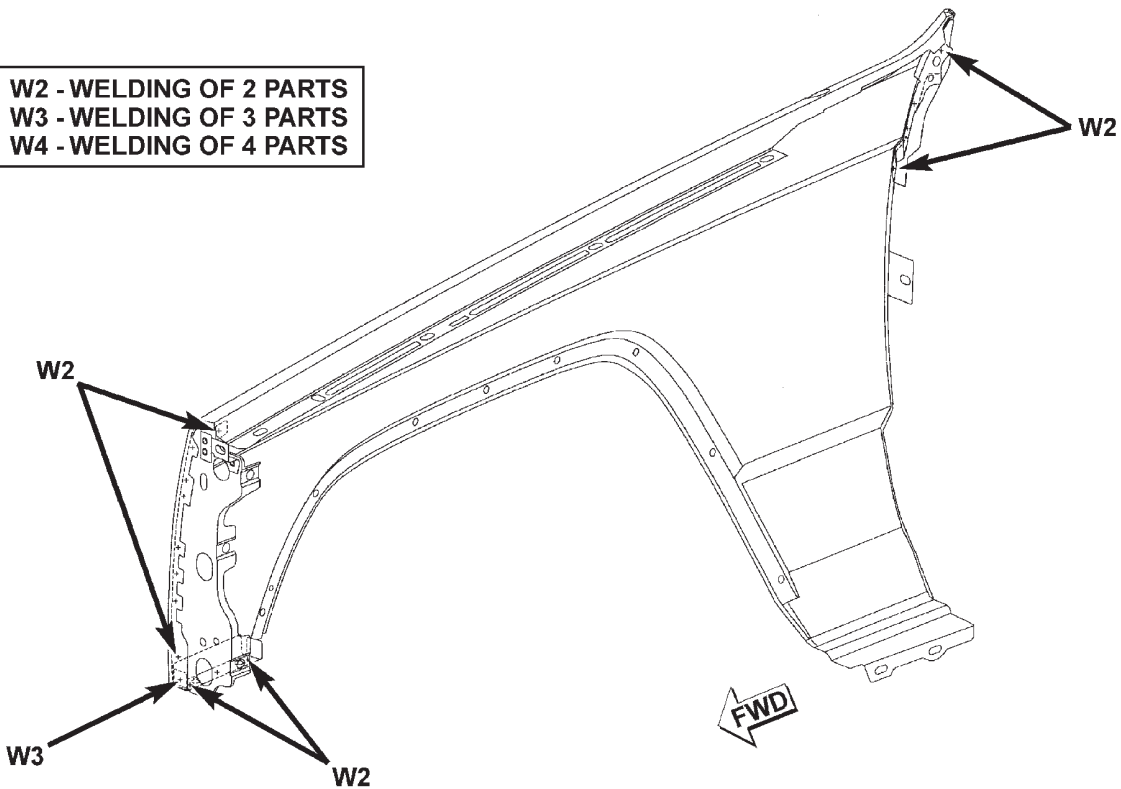

80b69904

SPECIFICATIONS (Continued)

BODY SIDE

W2 - WELDING OF 2 PARTS
W3 - WELDING OF 3 PARTS
W4 - WELDING OF 4 PARTS

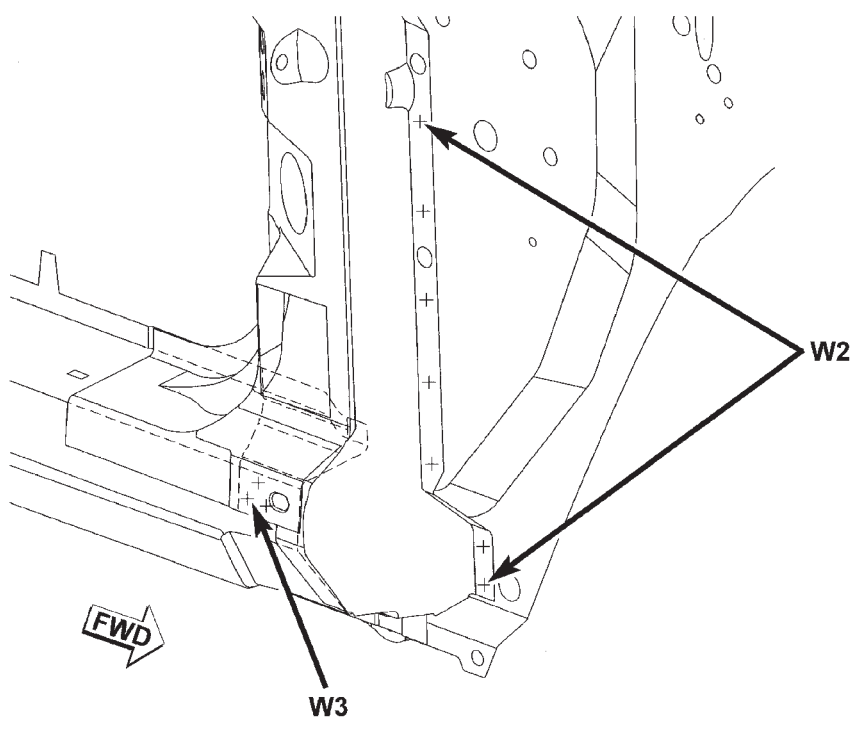
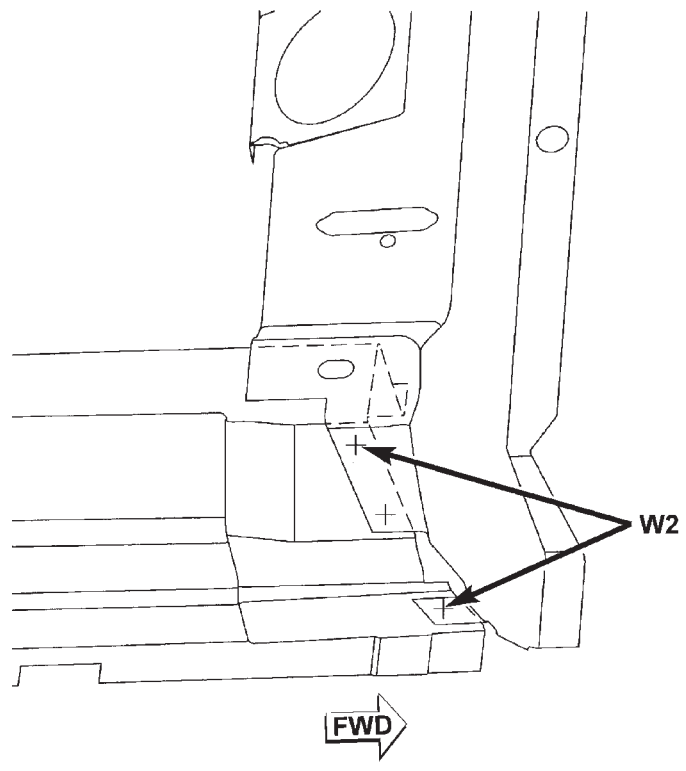
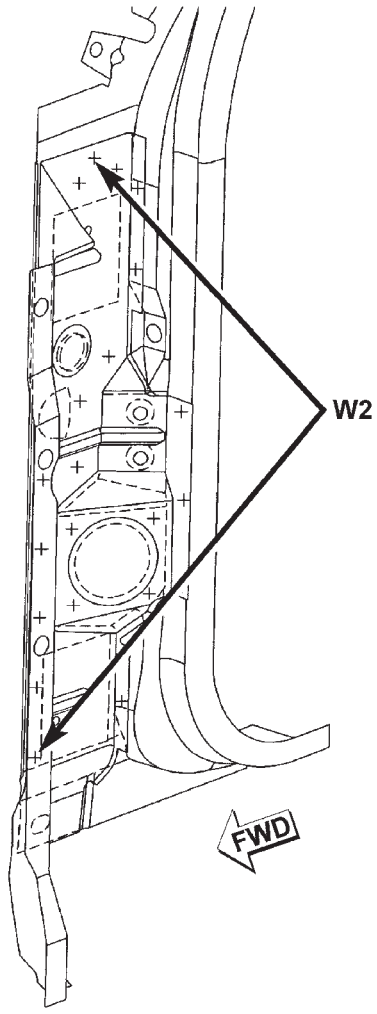

RIGHT SIDE SHOWN

SPECIFICATIONS (Continued)

REAR WHEELHOUSE

W2 - WELDING OF 2 PARTS
W3 - WELDING OF 3 PARTS
W4 - WELDING OF 4 PARTS

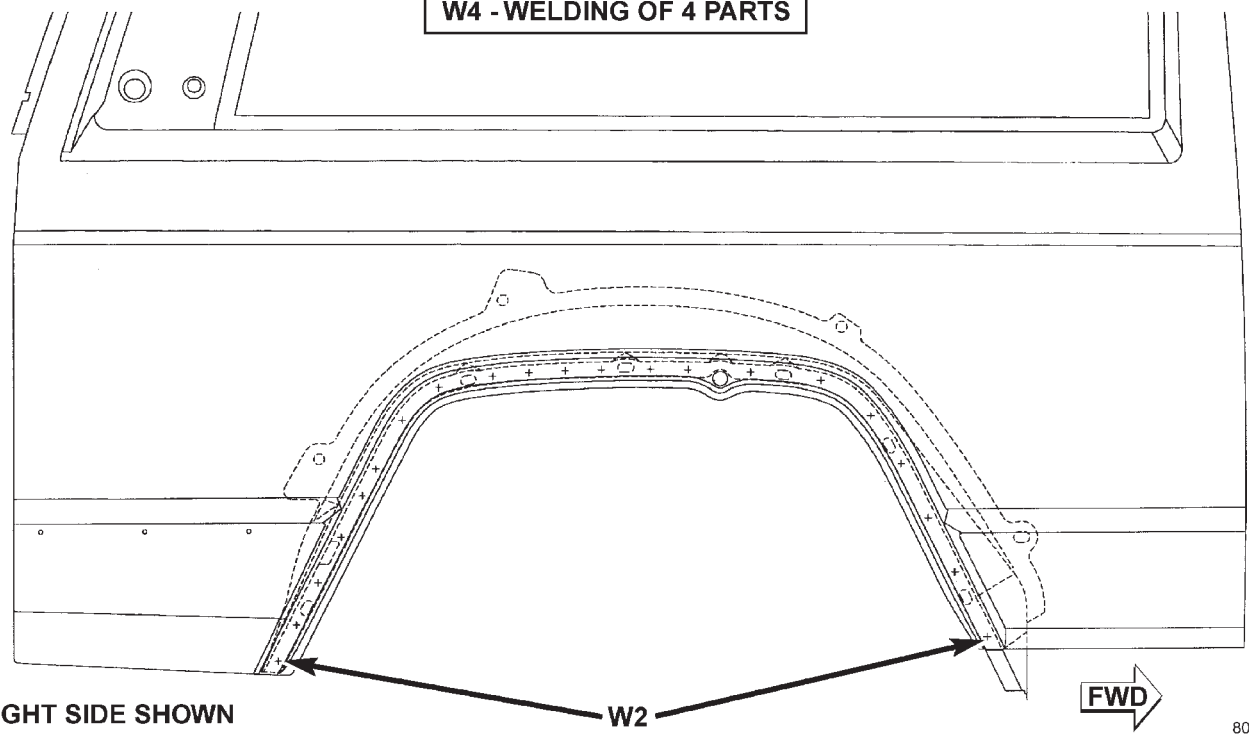

RIGHT SIDE SHOWN



80b69906

SPECIFICATIONS (Continued)

REAR INNER WHEELHOUSE

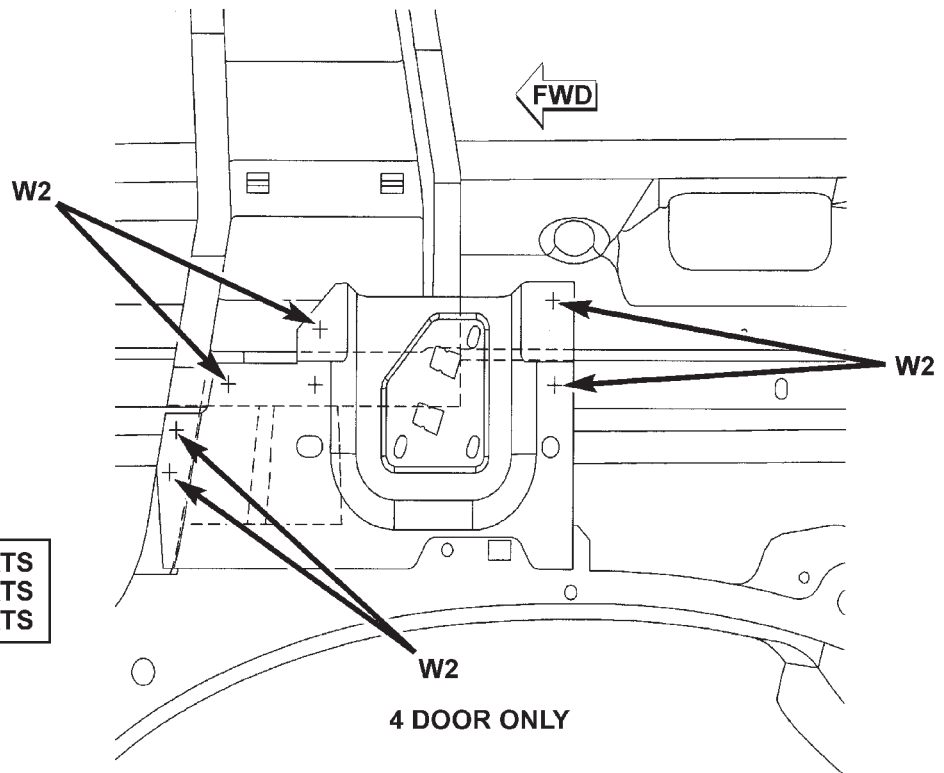
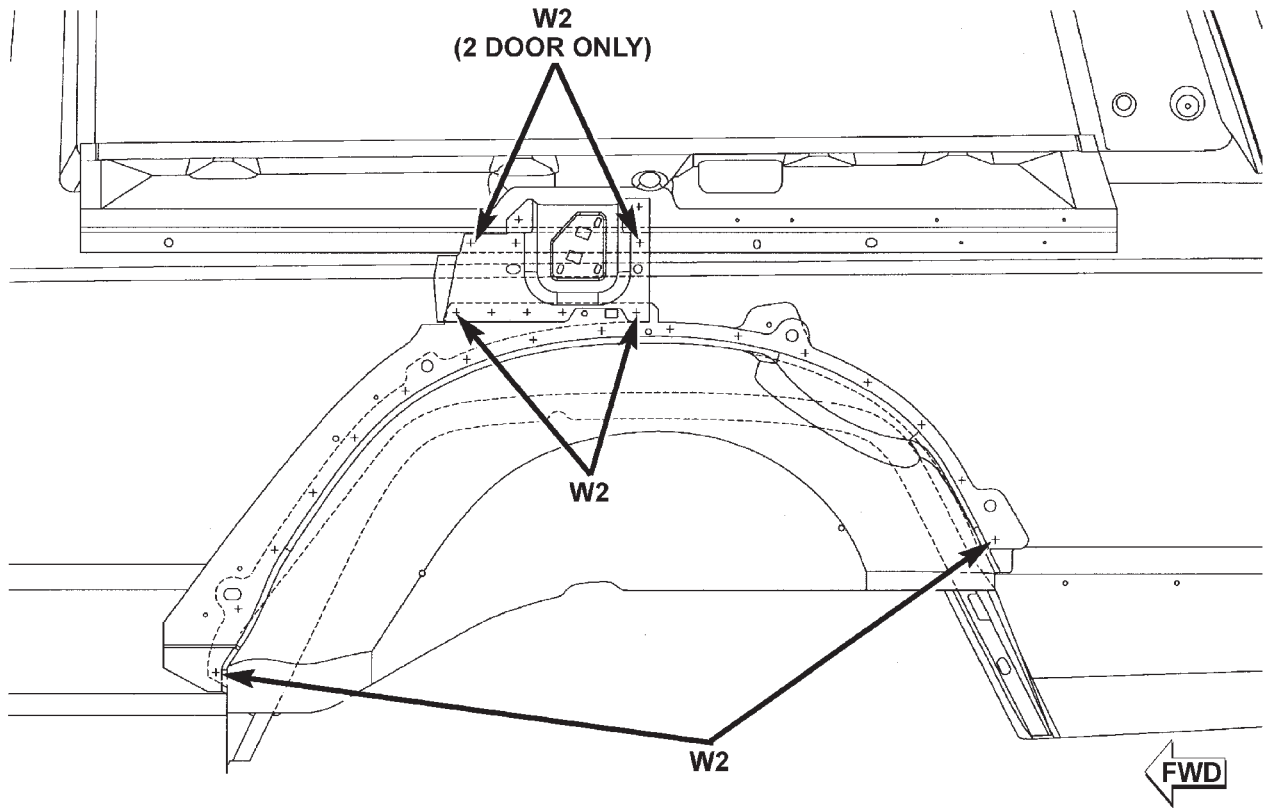

W2 - WELDING OF 2 PARTS
W3 - WELDING OF 3 PARTS
W4 - WELDING OF 4 PARTS

4 DOOR ONLY

RIGHT SIDE SHOWN

SPECIFICATIONS (Continued)

BODY SIDE

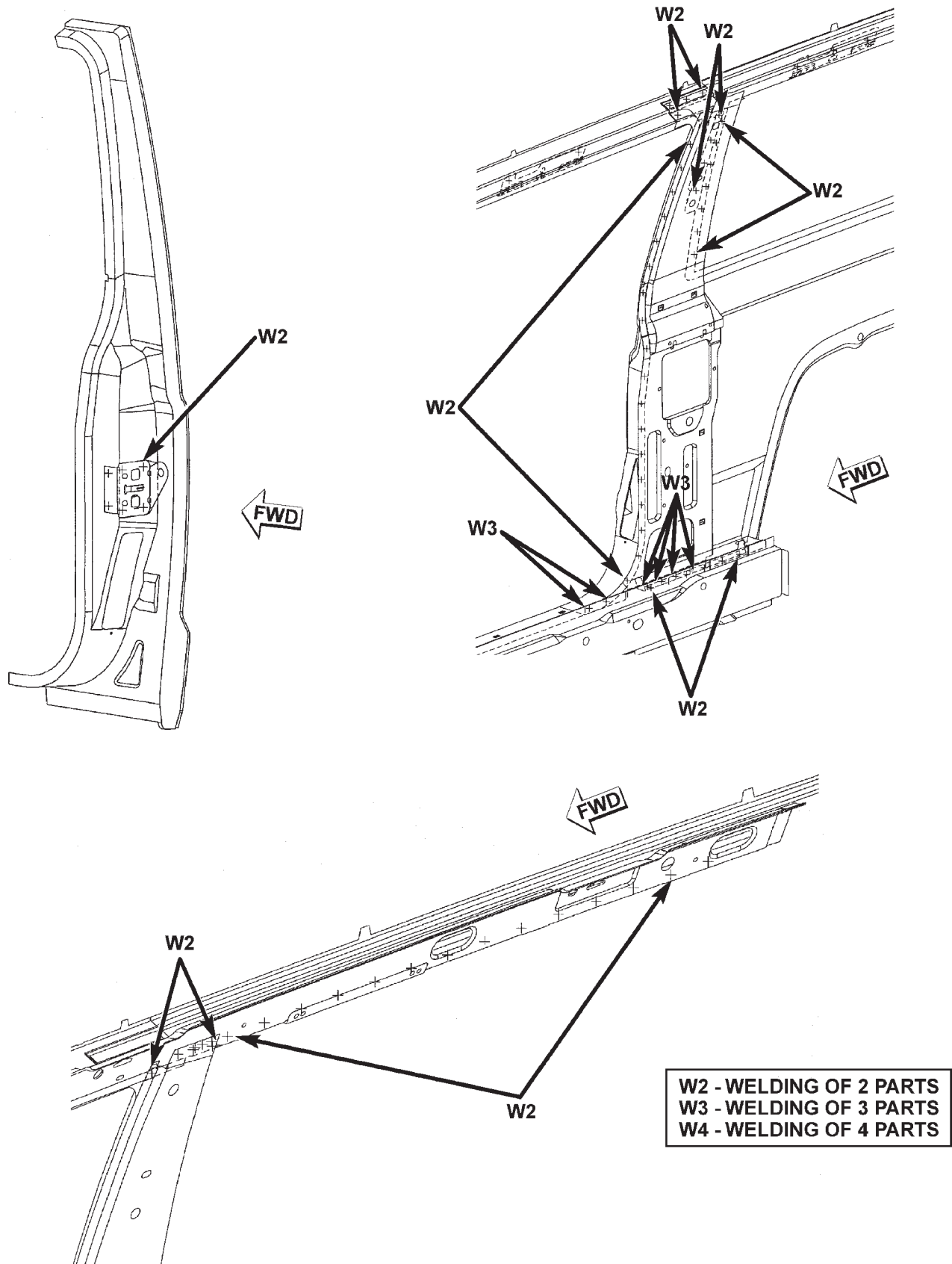

RIGHT SIDE SHOWN

SPECIFICATIONS (Continued)

BODY SIDE

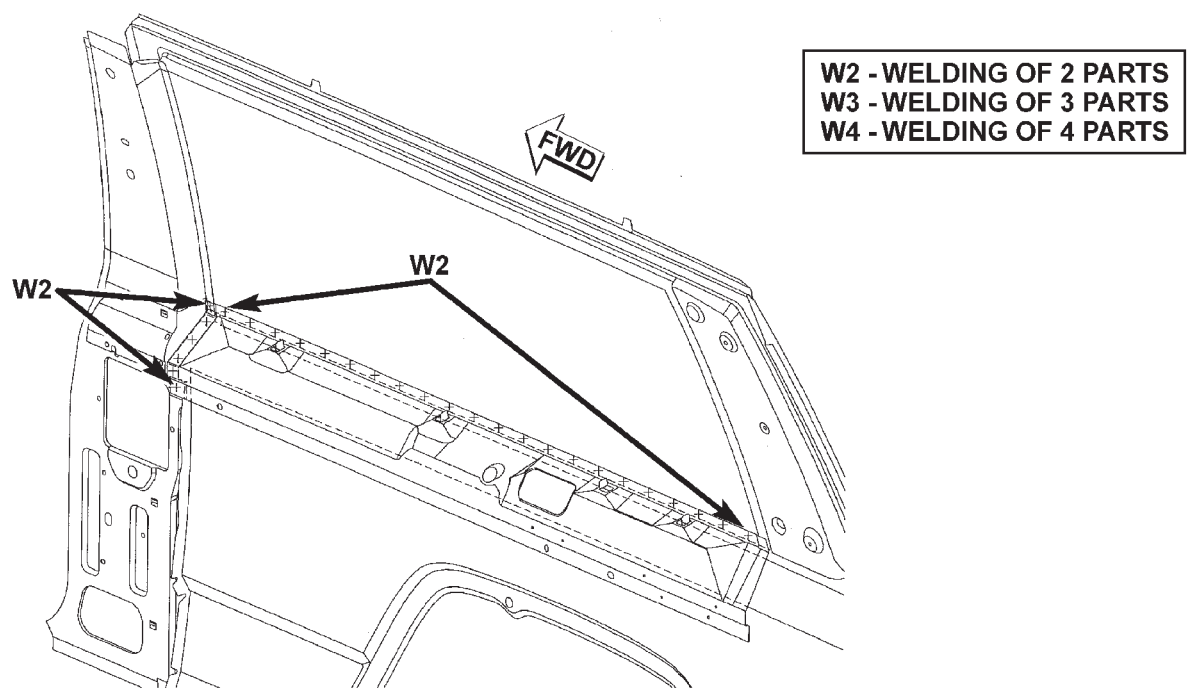

W2 - WELDING OF 2 PARTS
W3 - WELDING OF 3 PARTS
W4 - WELDING OF 4 PARTS

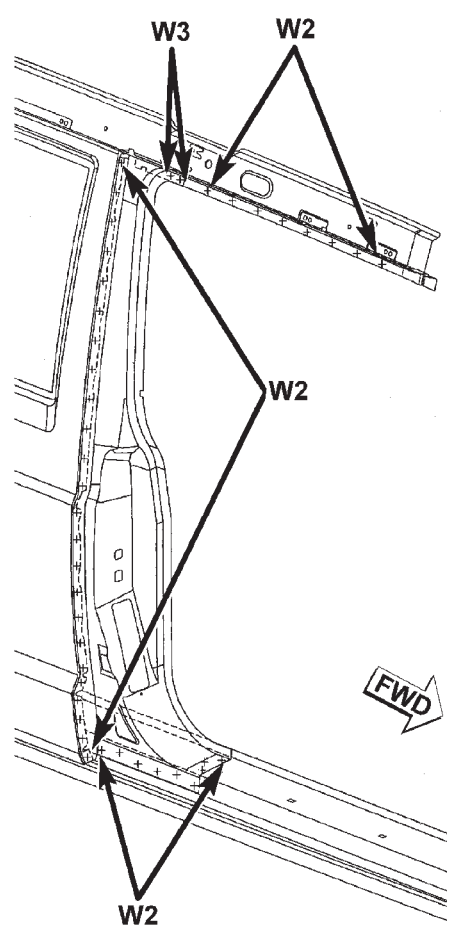

RIGHT SIDE SHOWN

SPECIFICATIONS (Continued)

BODY SIDE

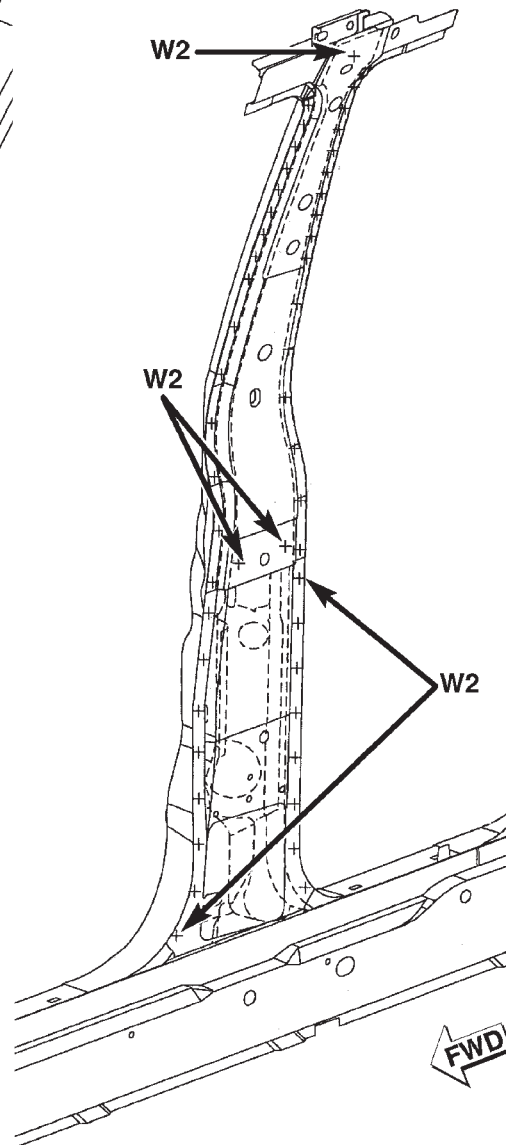
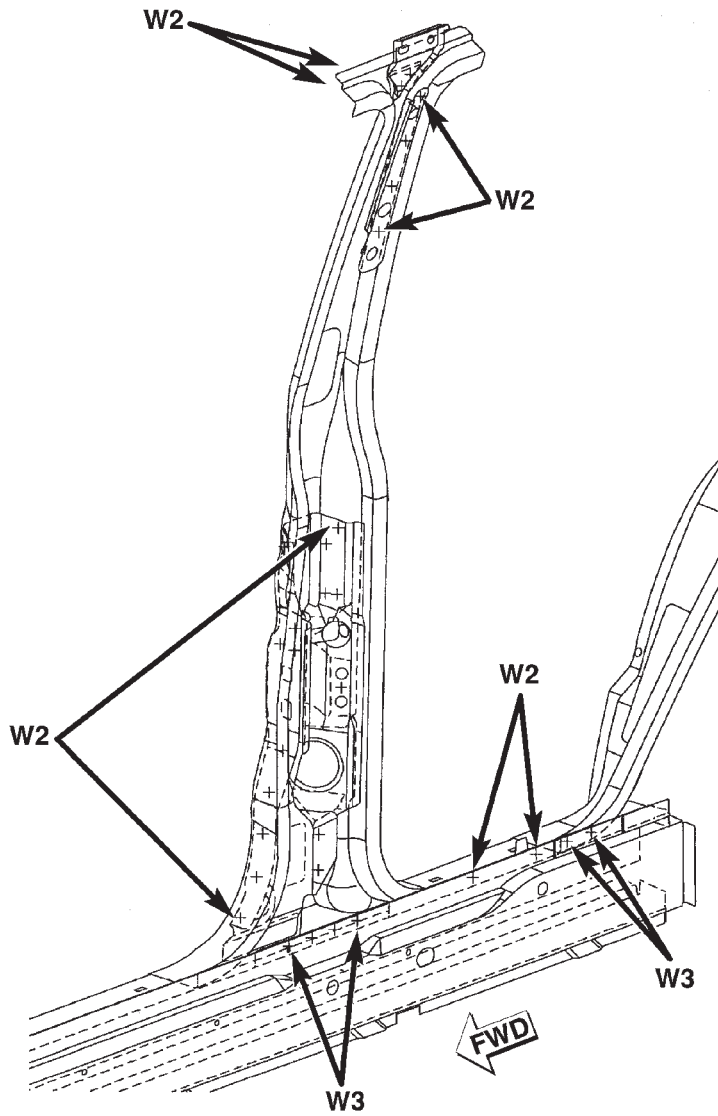

W2 - WELDING OF 2 PARTS
W3 - WELDING OF 3 PARTS
W4 - WELDING OF 4 PARTS

SPECIFICATIONS (Continued)

BODY SIDE

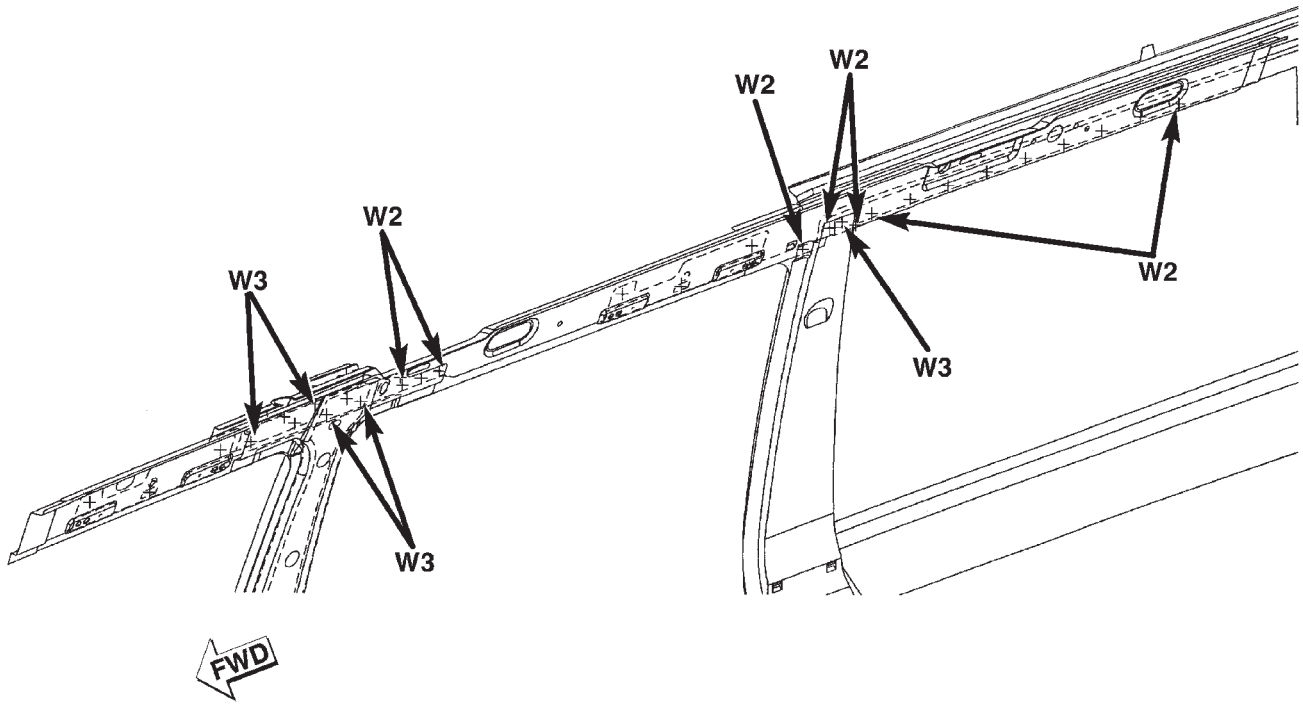

W2 - WELDING OF 2 PARTS
W3 - WELDING OF 3 PARTS
W4 - WELDING OF 4 PARTS

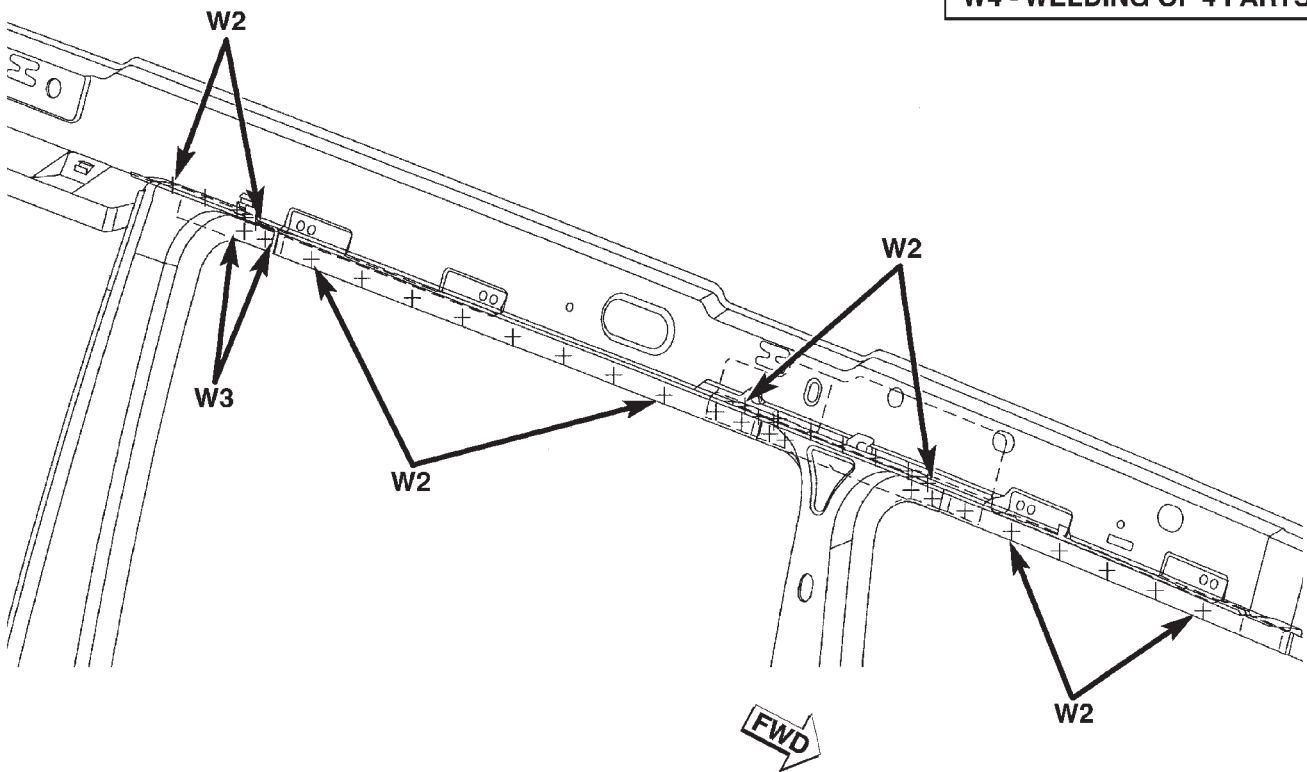

SPECIFICATIONS (Continued)

BODY SIDE

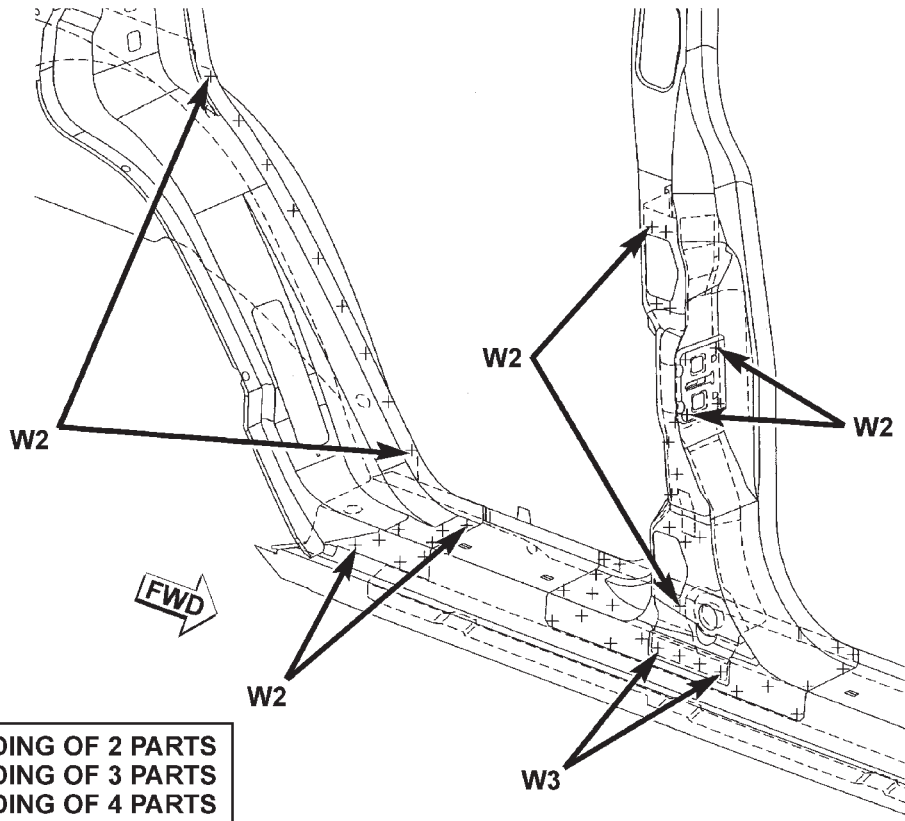

SPECIFICATIONS (Continued)

BODY SIDE

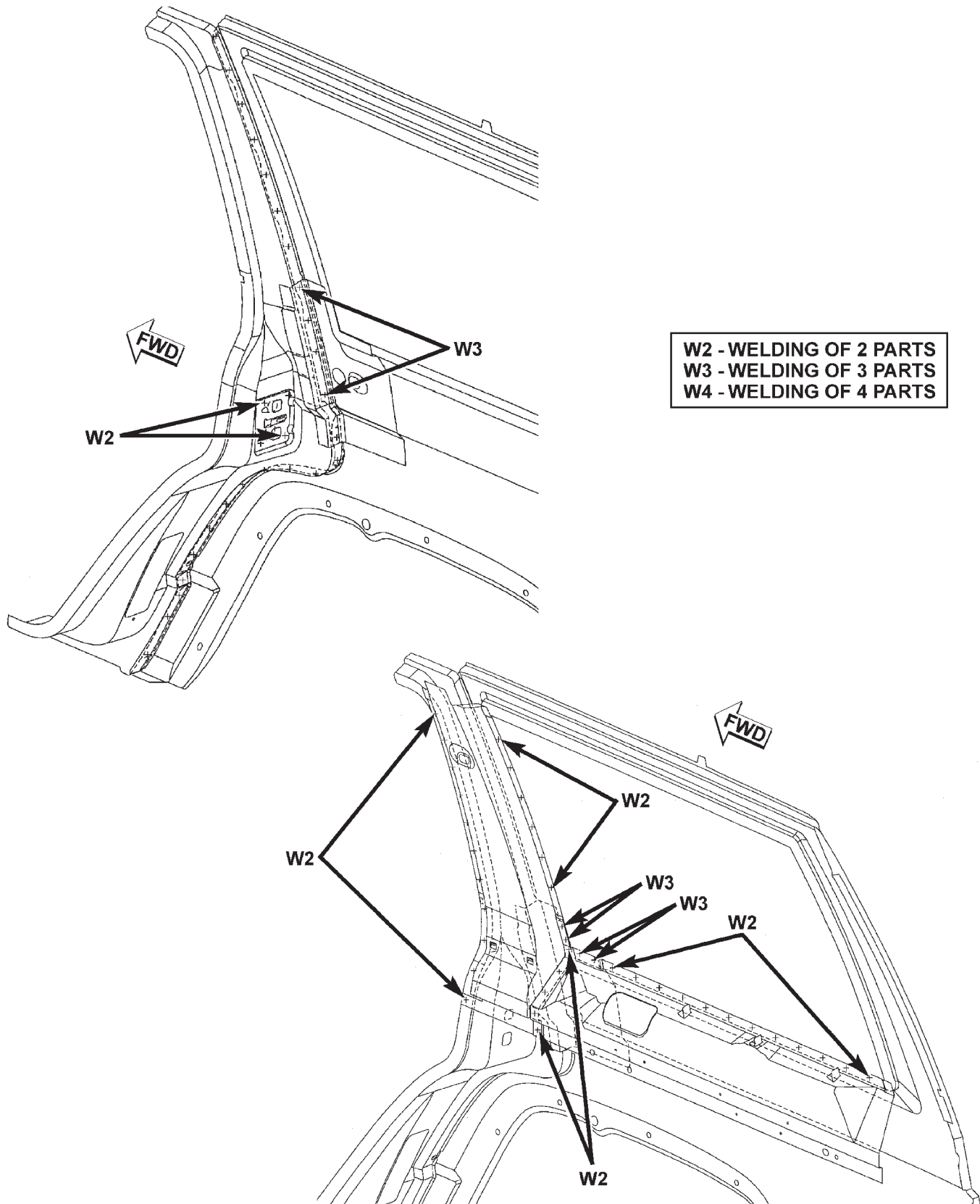

SPECIFICATIONS (Continued)

UNDERBODY

80c698ef

W2 - WELDING OF 2 PARTS
W3 - WELDING OF 3 PARTS
W4 - WELDING OF 4 PARTS

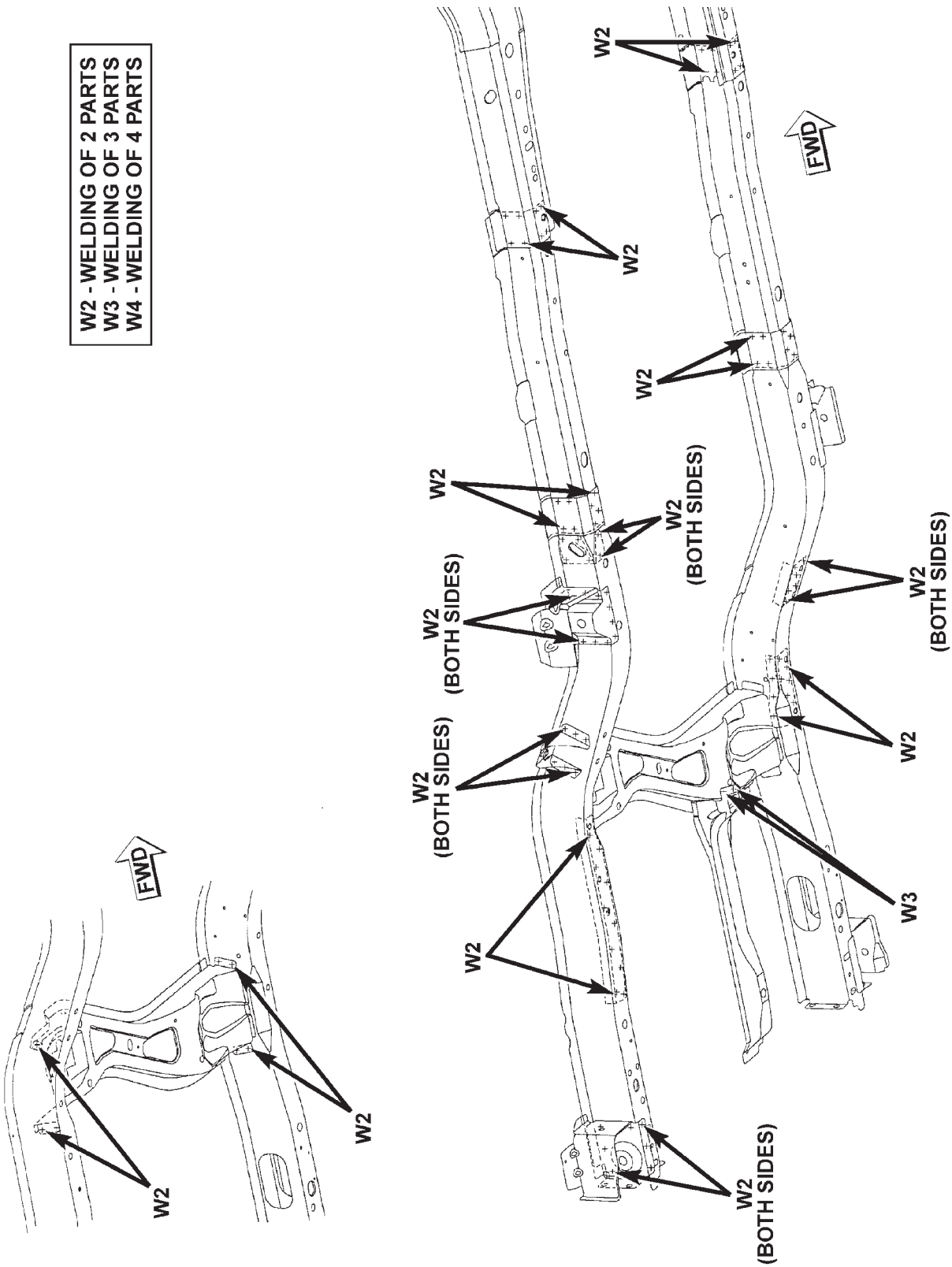

SPECIFICATIONS (Continued)

UNDERBODY

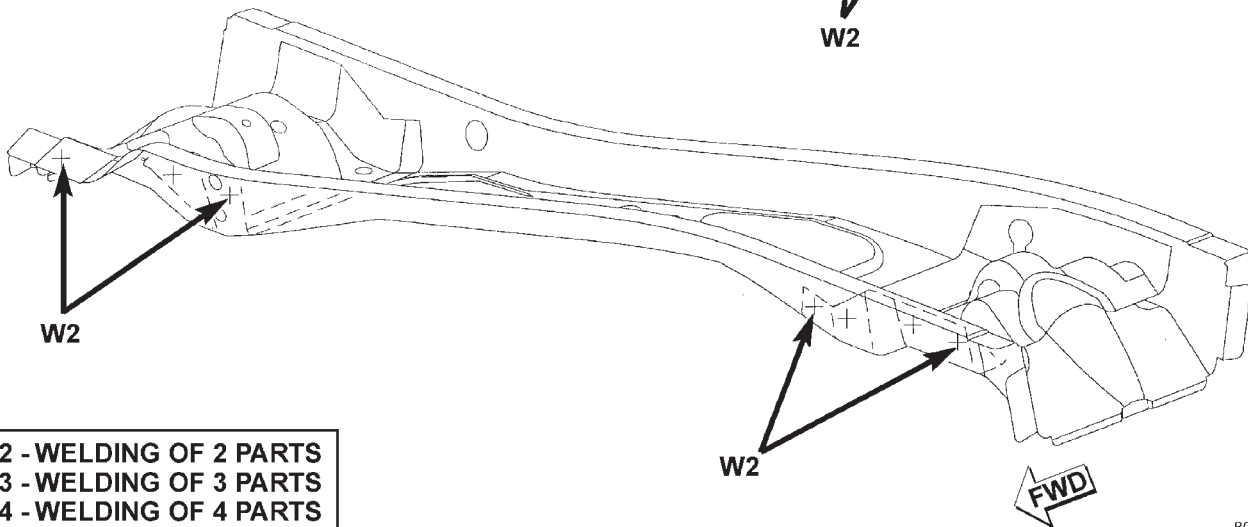
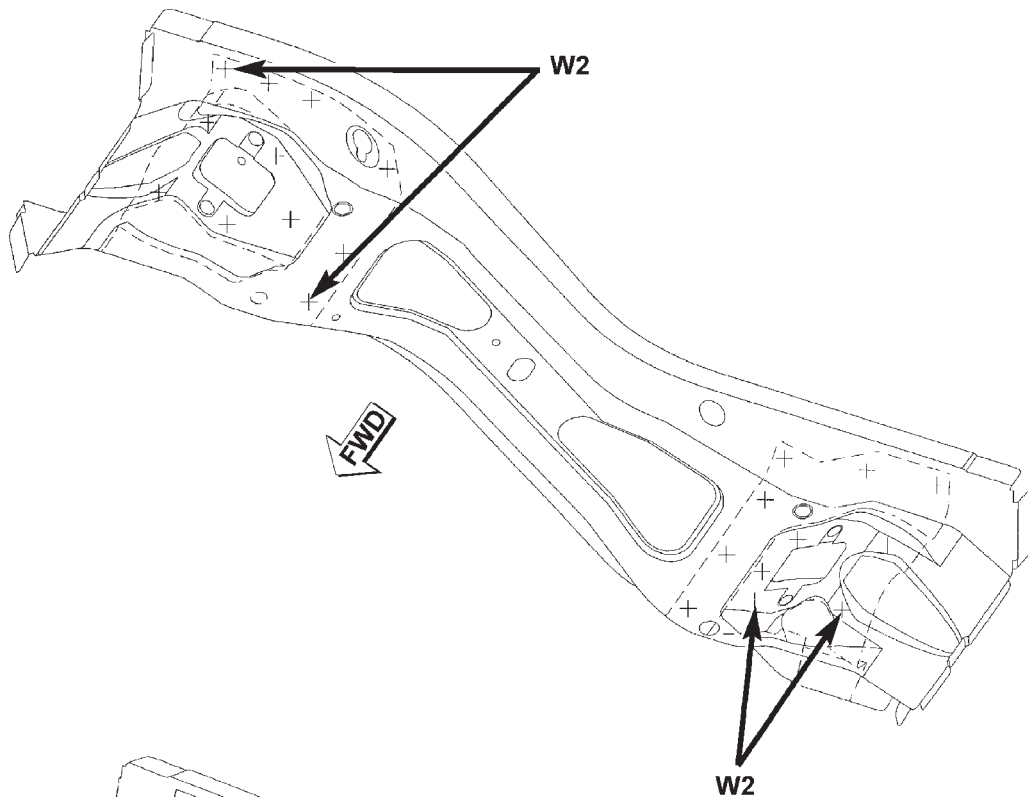
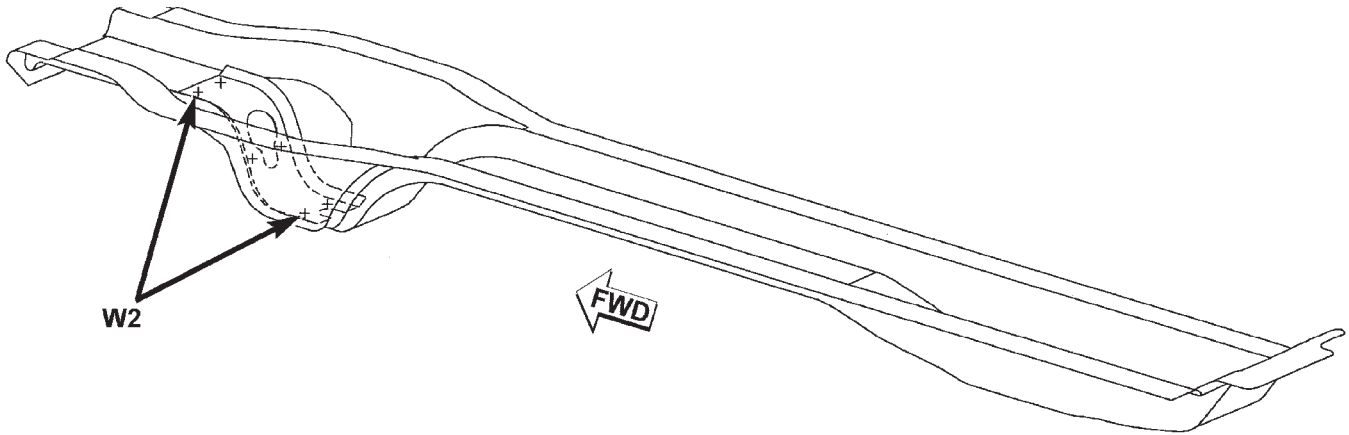

W2 - WELDING OF 2 PARTS
W3 - WELDING OF 3 PARTS
W4 - WELDING OF 4 PARTS

SPECIFICATIONS (Continued)

UNDERBODY

W2 - WELDING OF 2 PARTS
W3 - WELDING OF 3 PARTS
W4 - WELDING OF 4 PARTS

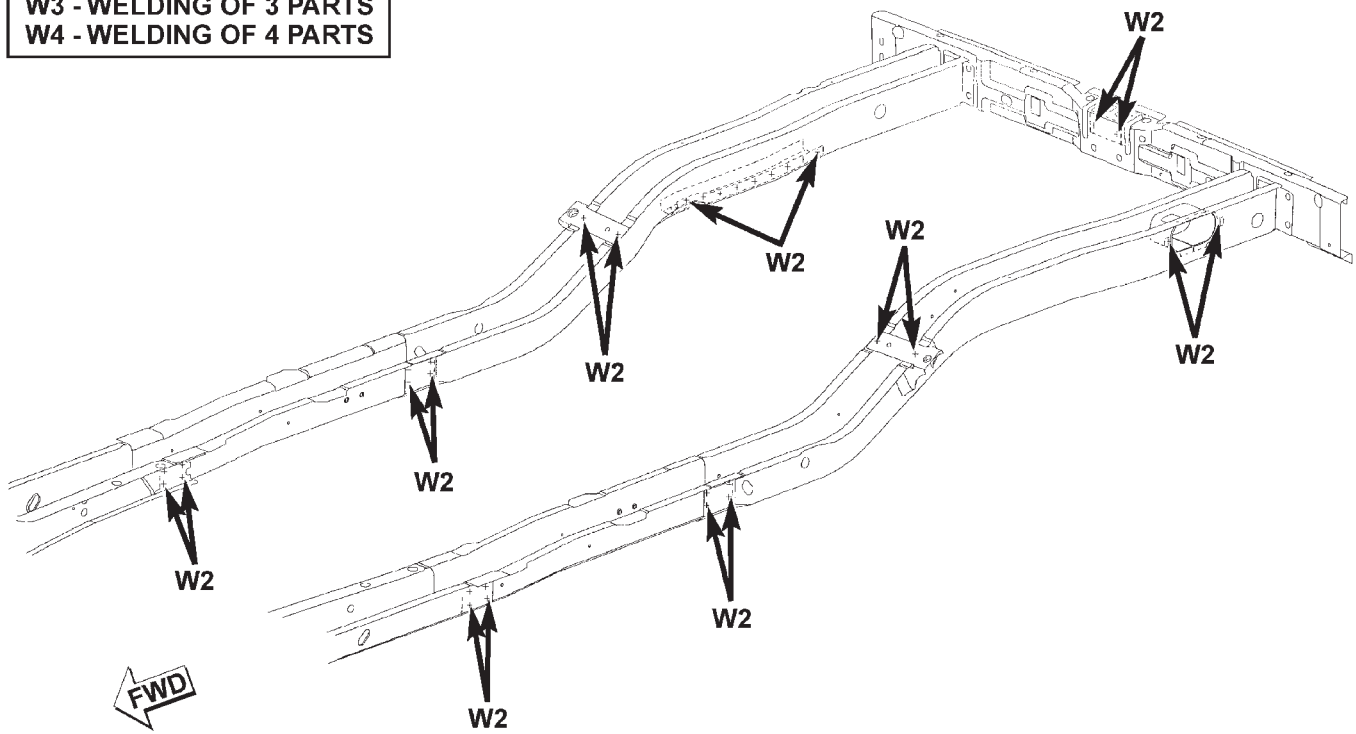

SPECIFICATIONS (Continued)

UNDERBODY

80c69812

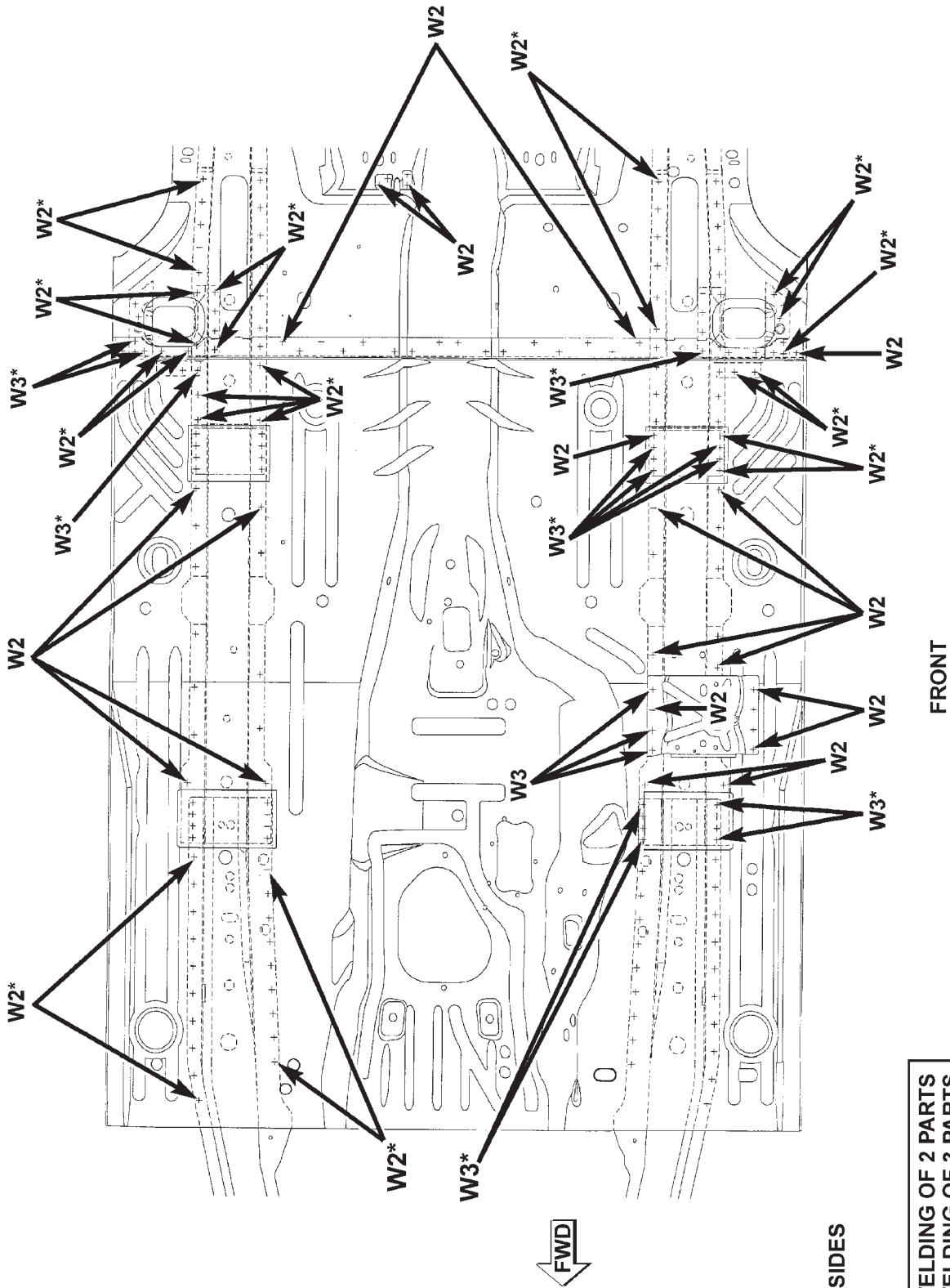

*BOTH SIDES

- W2 - WELDING OF 2 PARTS
- W3 - WELDING OF 3 PARTS
- W4 - WELDING OF 4 PARTS

SPECIFICATIONS (Continued)

UNDERBODY

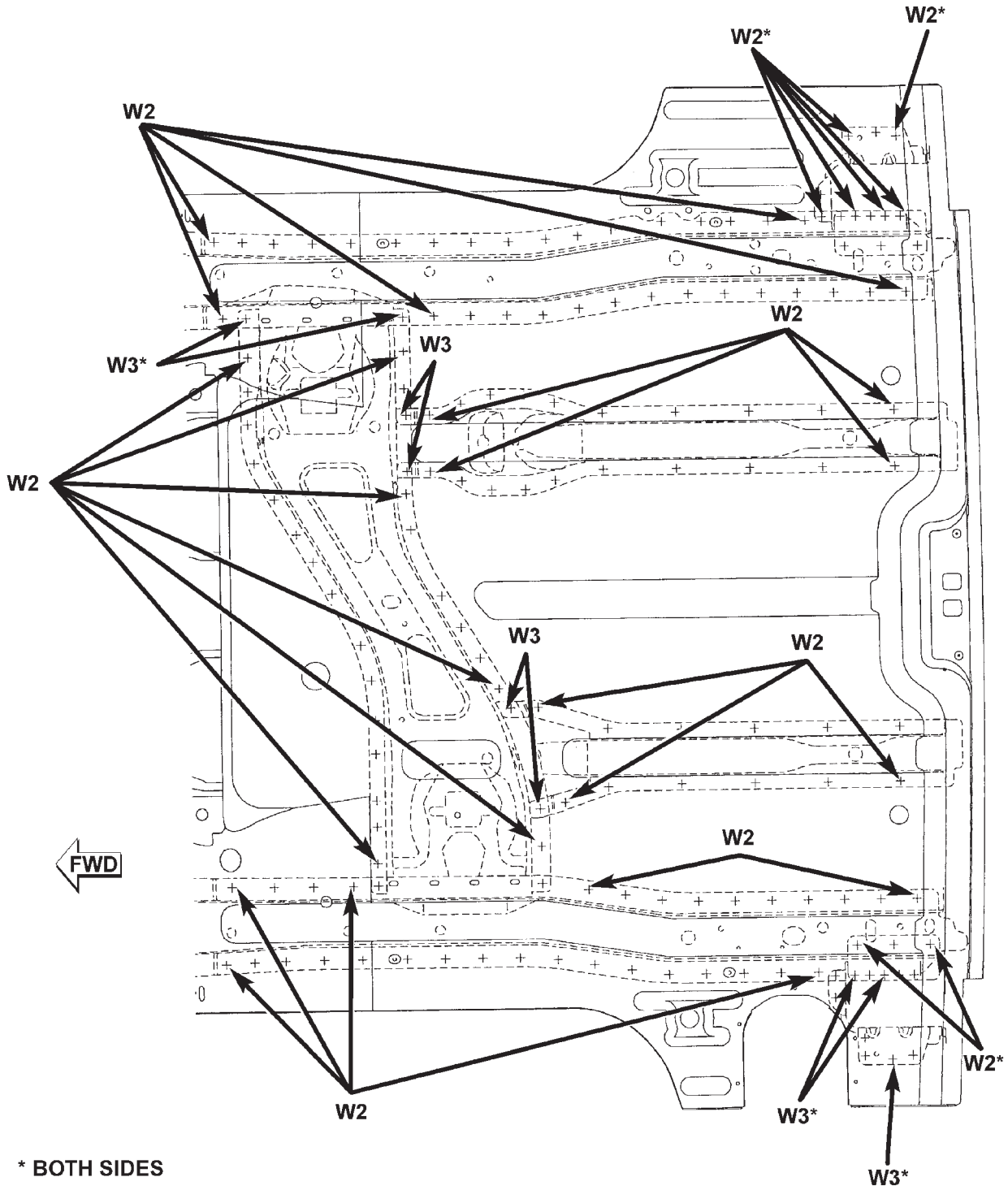

* BOTH SIDES

W2 - WELDING OF 2 PARTS
W3 - WELDING OF 3 PARTS
W4 - WELDING OF 4 PARTS

REAR

SPECIFICATIONS (Continued)

UNDERBODY

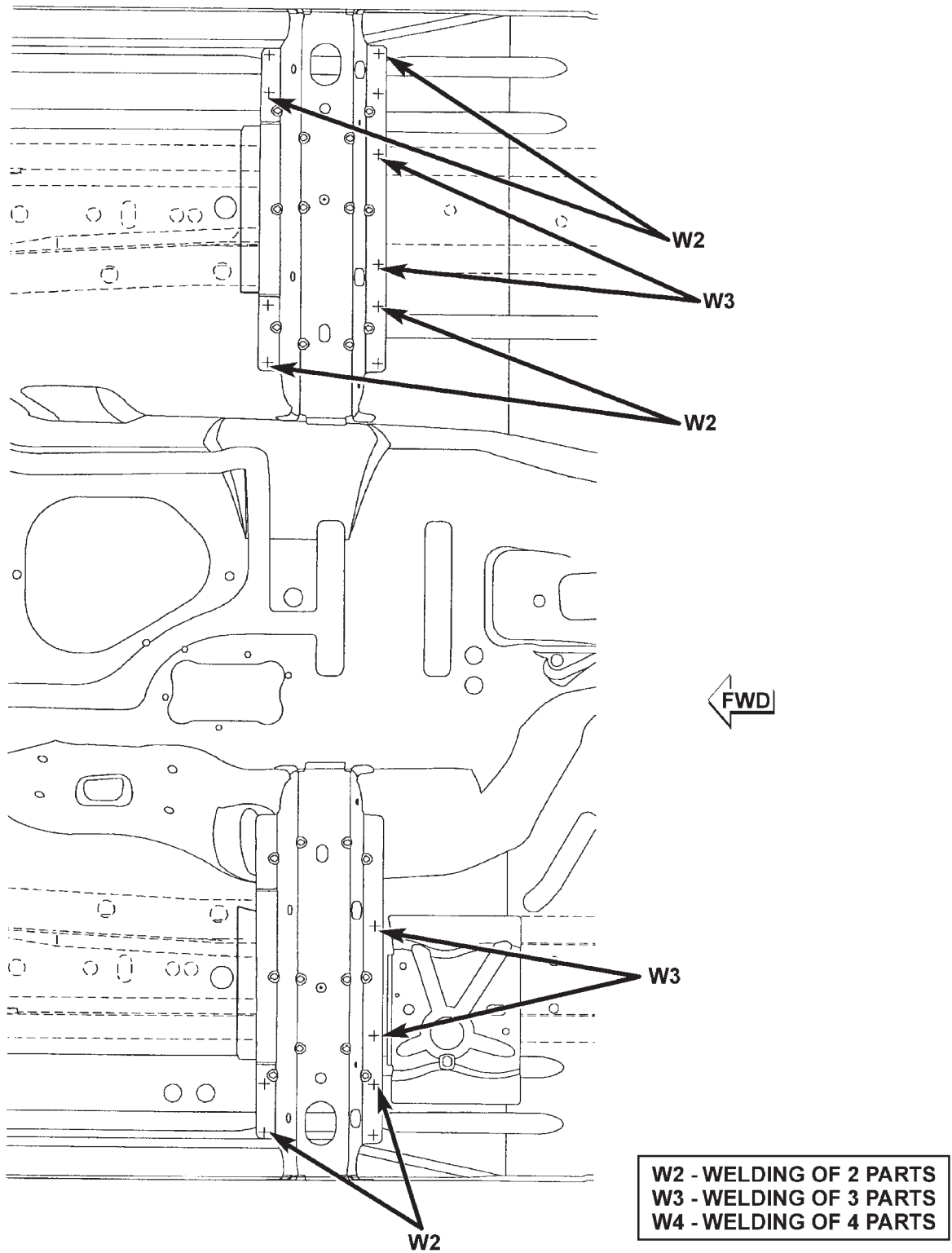

SPECIFICATIONS (Continued)

UNDERBODY

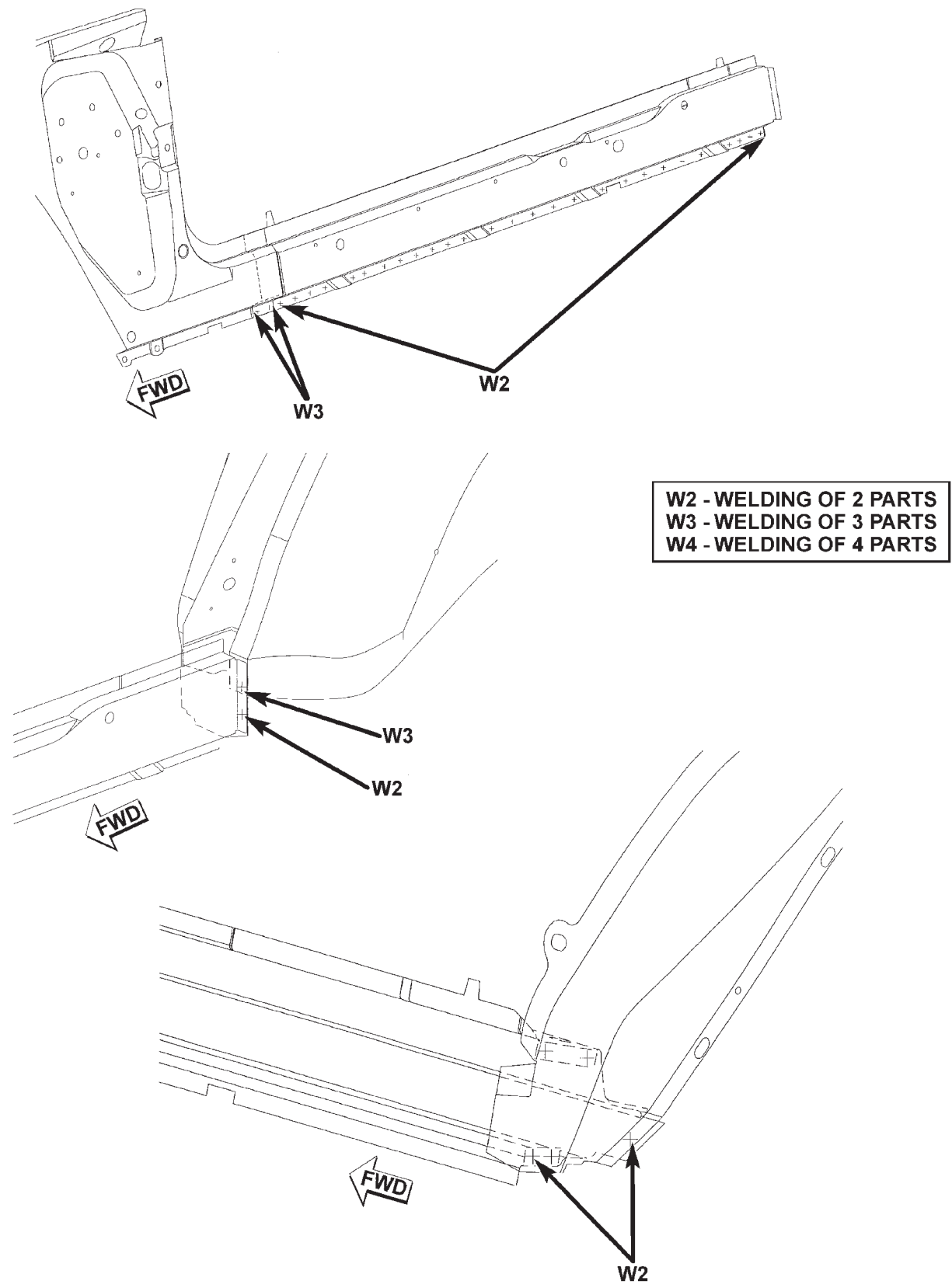

SPECIFICATIONS (Continued)

UNDERBODY

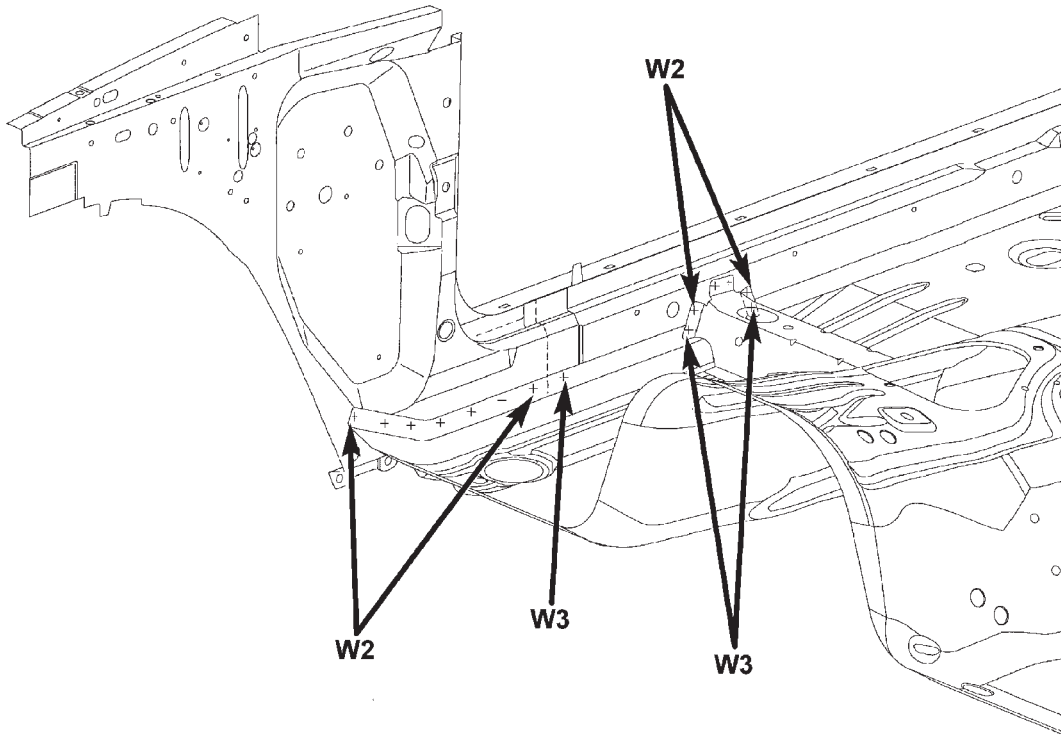

W2 - WELDING OF 2 PARTS
W3 - WELDING OF 3 PARTS
W4 - WELDING OF 4 PARTS

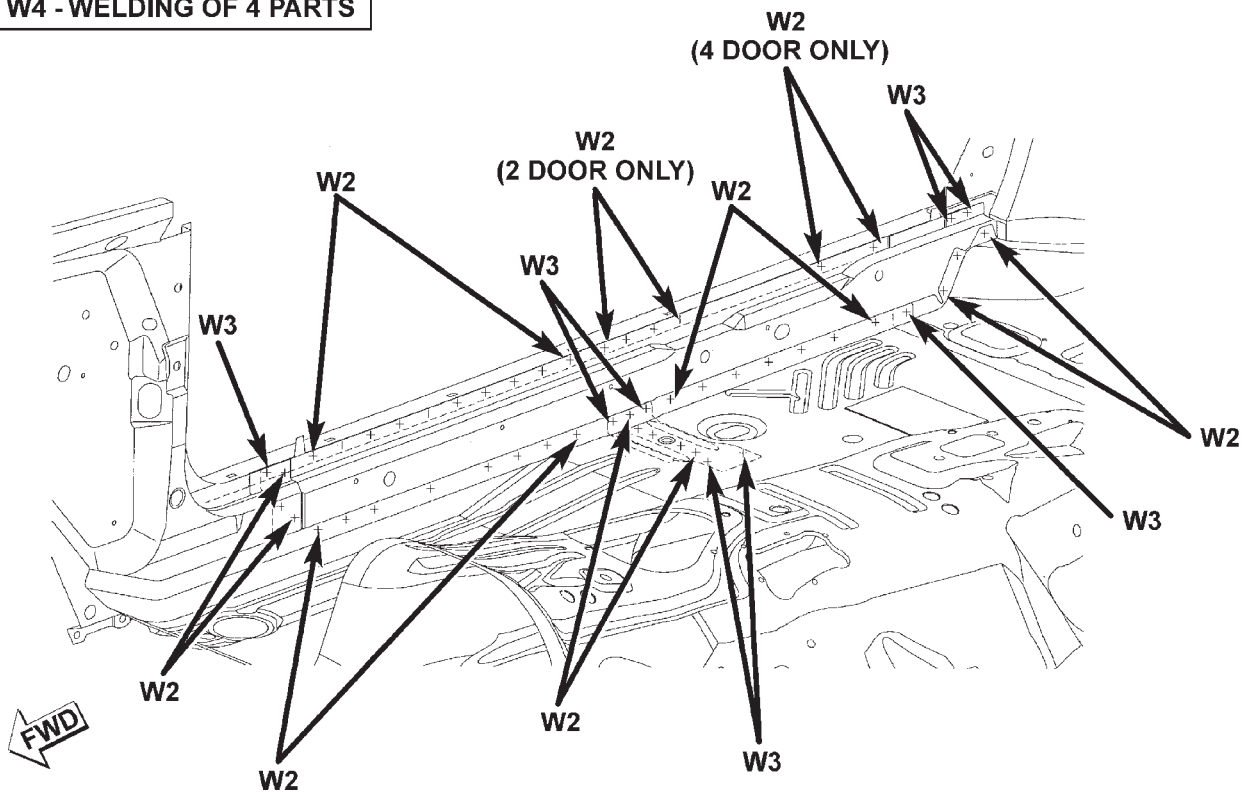

SPECIFICATIONS (Continued)

UNDERBODY

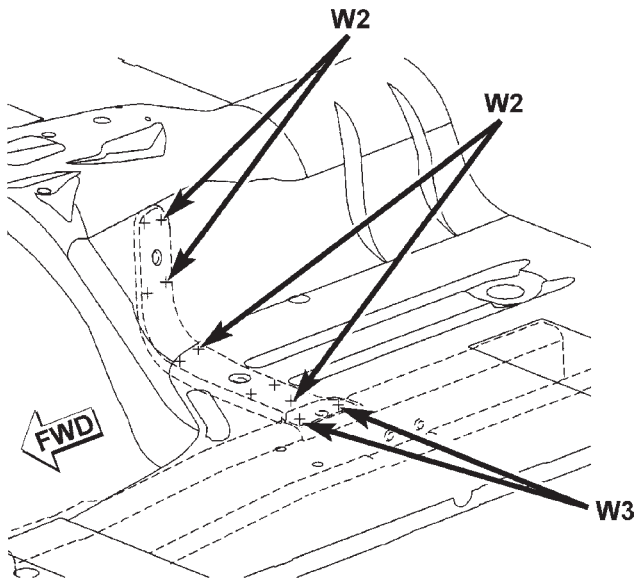

LEFT SIDE

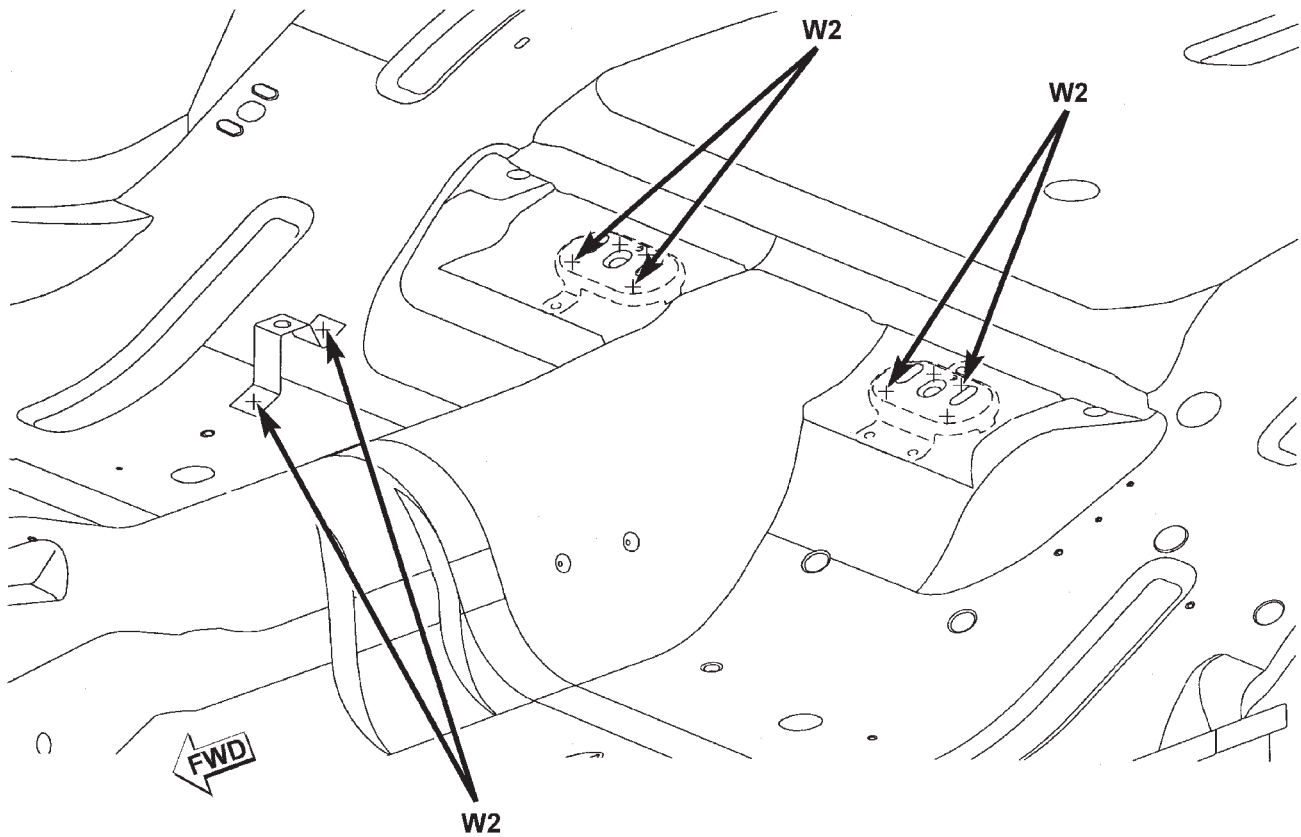
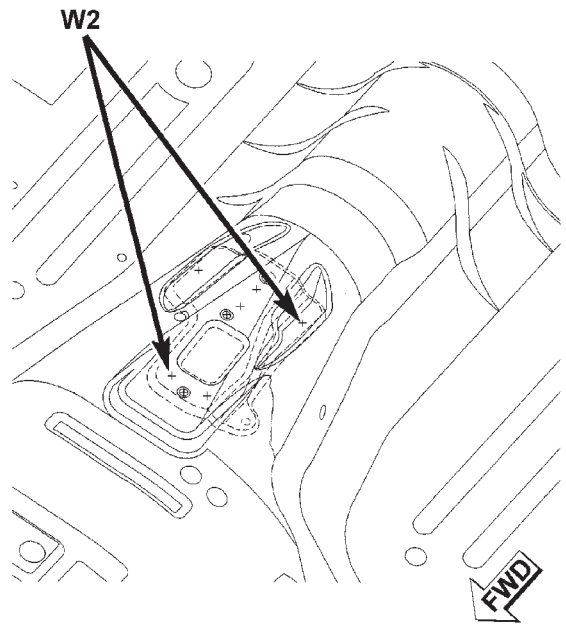

W2 - WELDING OF 2 PARTS
W3 - WELDING OF 3 PARTS
W4 - WELDING OF 4 PARTS

SPECIFICATIONS (Continued)

UNDERBODY

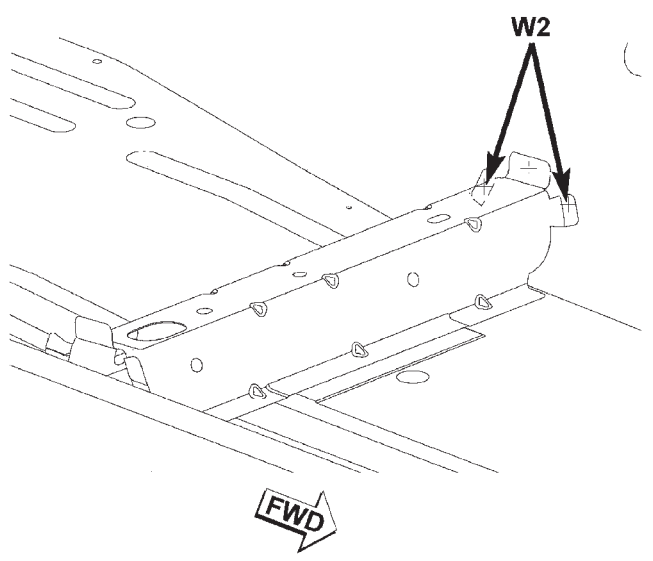
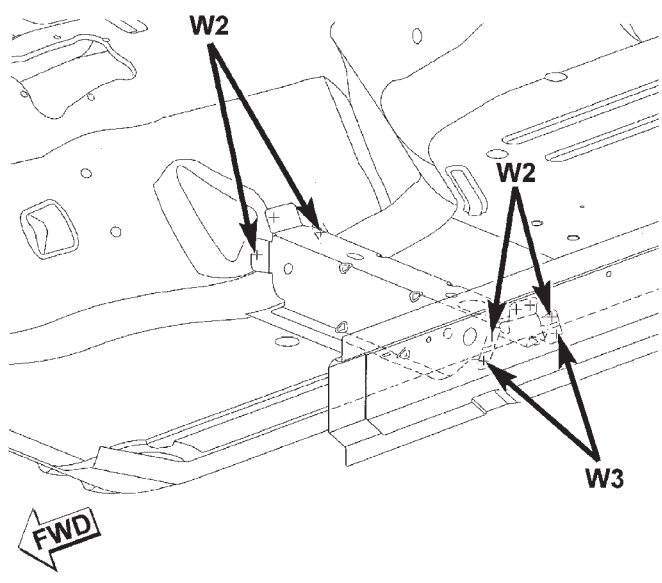

W2 - WELDING OF 2 PARTS
W3 - WELDING OF 3 PARTS
W4 - WELDING OF 4 PARTS

SPECIFICATIONS (Continued)

UNDERBODY

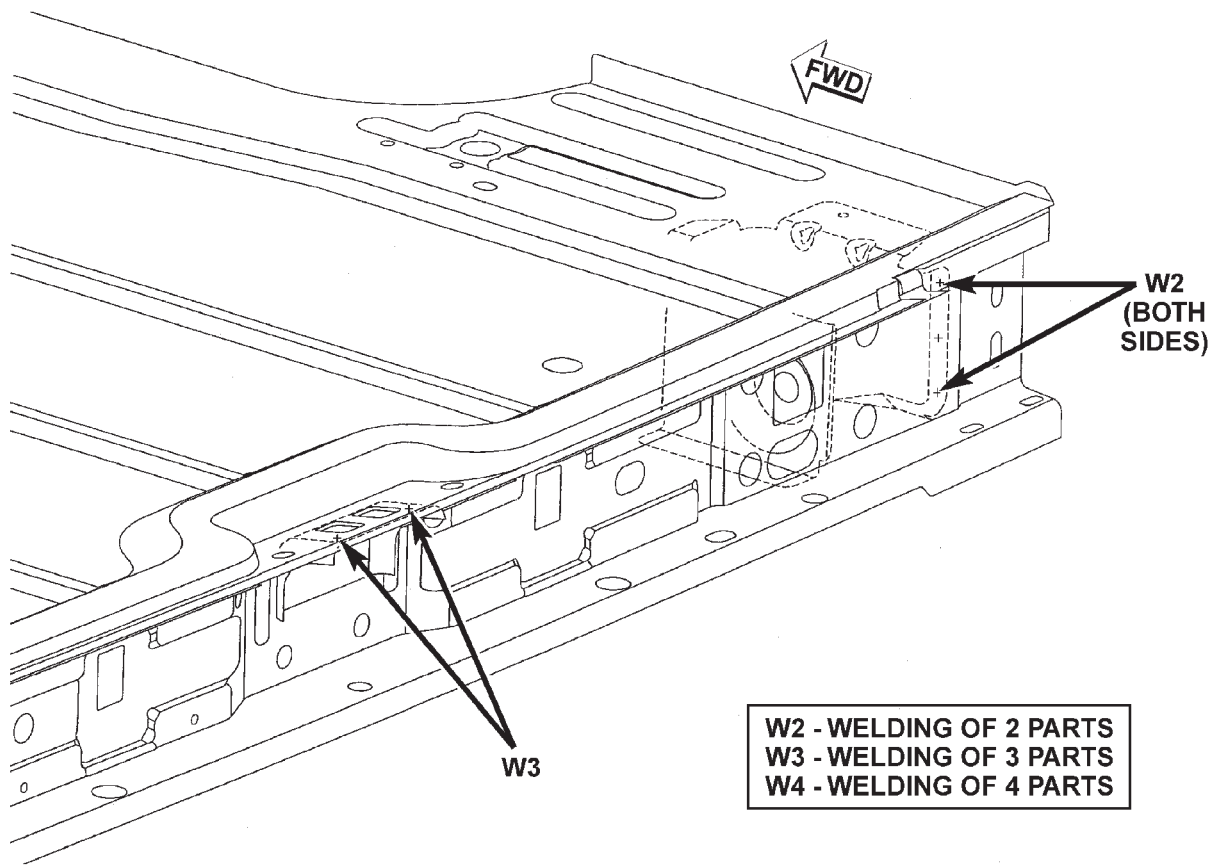
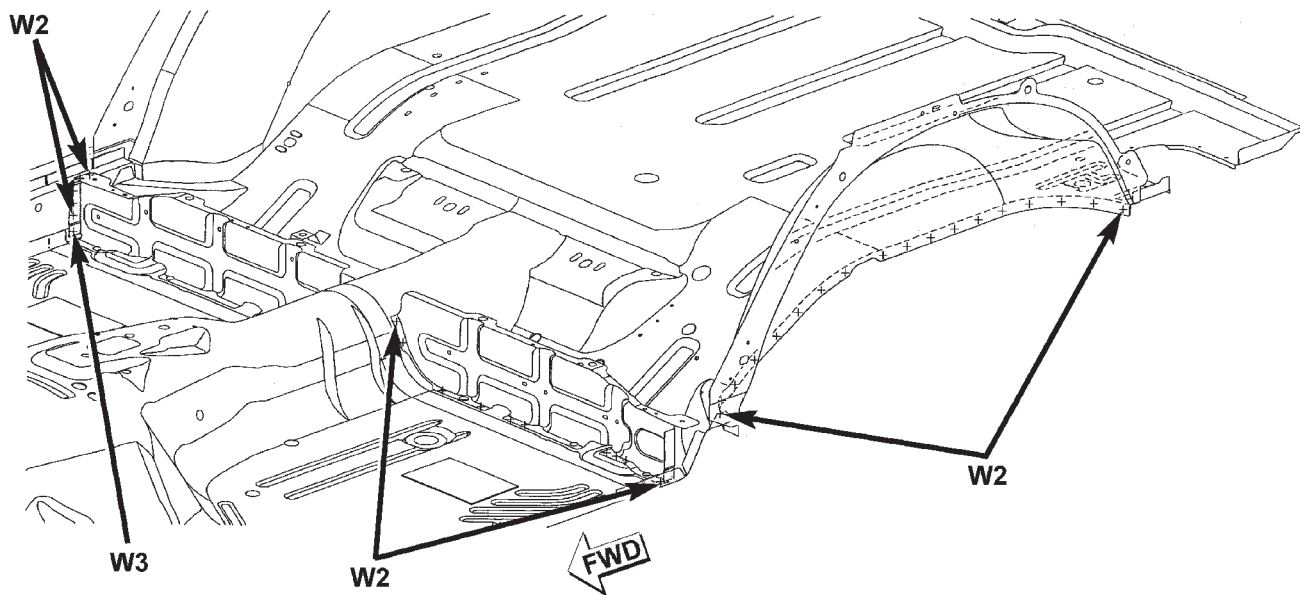

W2 - WELDING OF 2 PARTS
W3 - WELDING OF 3 PARTS
W4 - WELDING OF 4 PARTS

SPECIFICATIONS (Continued)

BODY SEALING LOCATIONS

APPLICATION METHODS

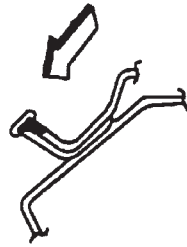

HOLD GUN NOZZLE IN DIRECTION OF ARROW IN ORDER TO EFFECTIVELY SEAL METAL JOINTS.

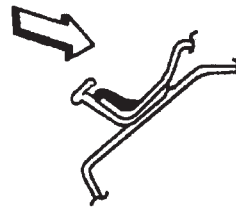

DO NOT HOLD GUN NOZZLE IN DIRECTION OF ARROW. SEALER APPLIED AS SHOWN IN INEFFECTIVE.

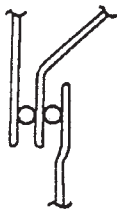

3 METAL THICKNESS

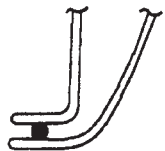

2 METAL THICKNESS

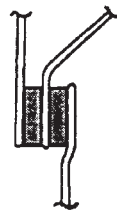



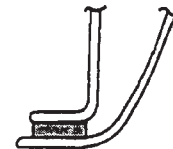

3 METAL THICKNESS

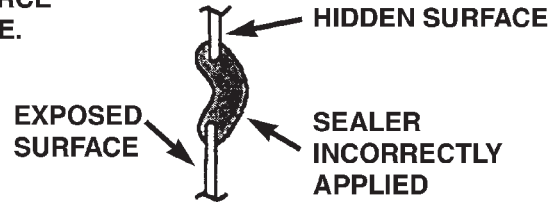
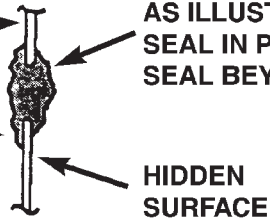

2 METAL THICKNESS

EXPOSED SURFACE →
WORK SEAL ON METAL SURFACE TO GET GOOD ADHESIVE. EDGE MUST BE FEATHERED AS SHOWN.



SYMBOLS	
	THUMBGRADEABLE SEALER
	EXTRUDABLE THERMOPLASTIC
	EXPOSED THERMOPLASTIC SEALANT
	HIDDEN SEALANT

SPECIFICATIONS (Continued)

COWL AND DASH PANEL

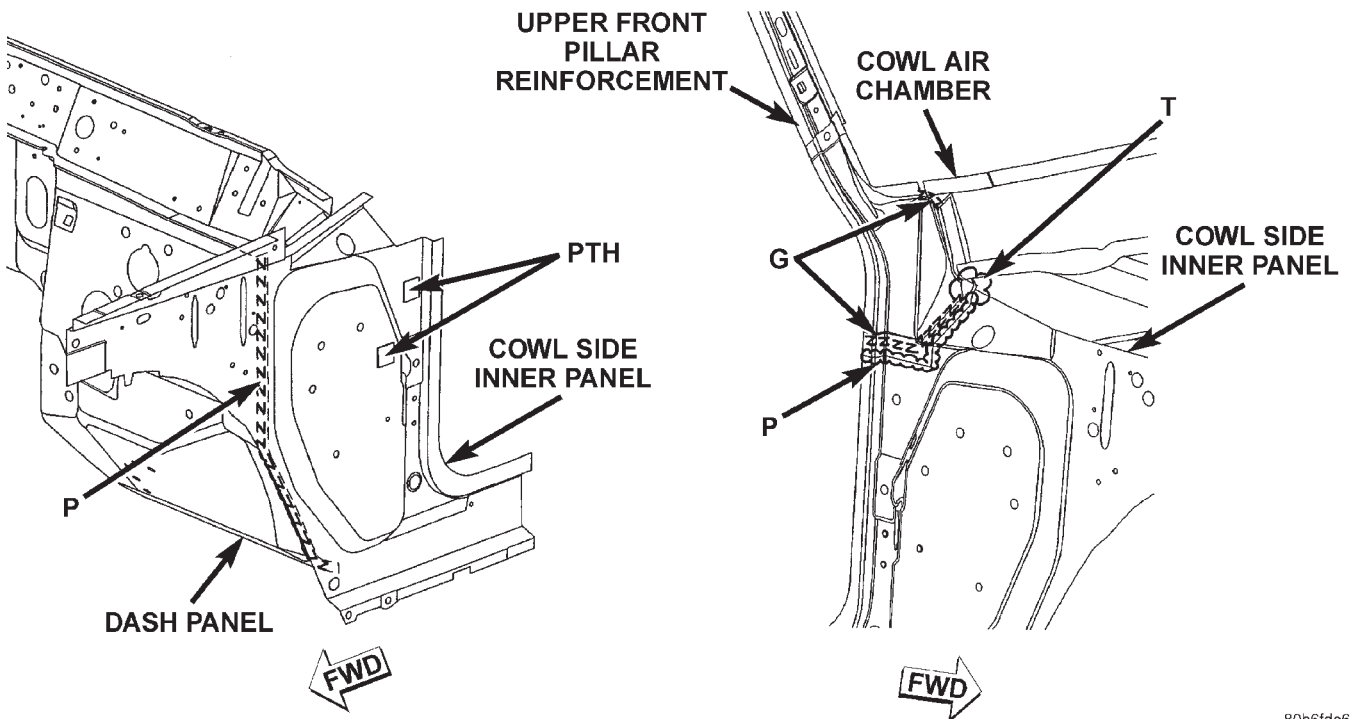
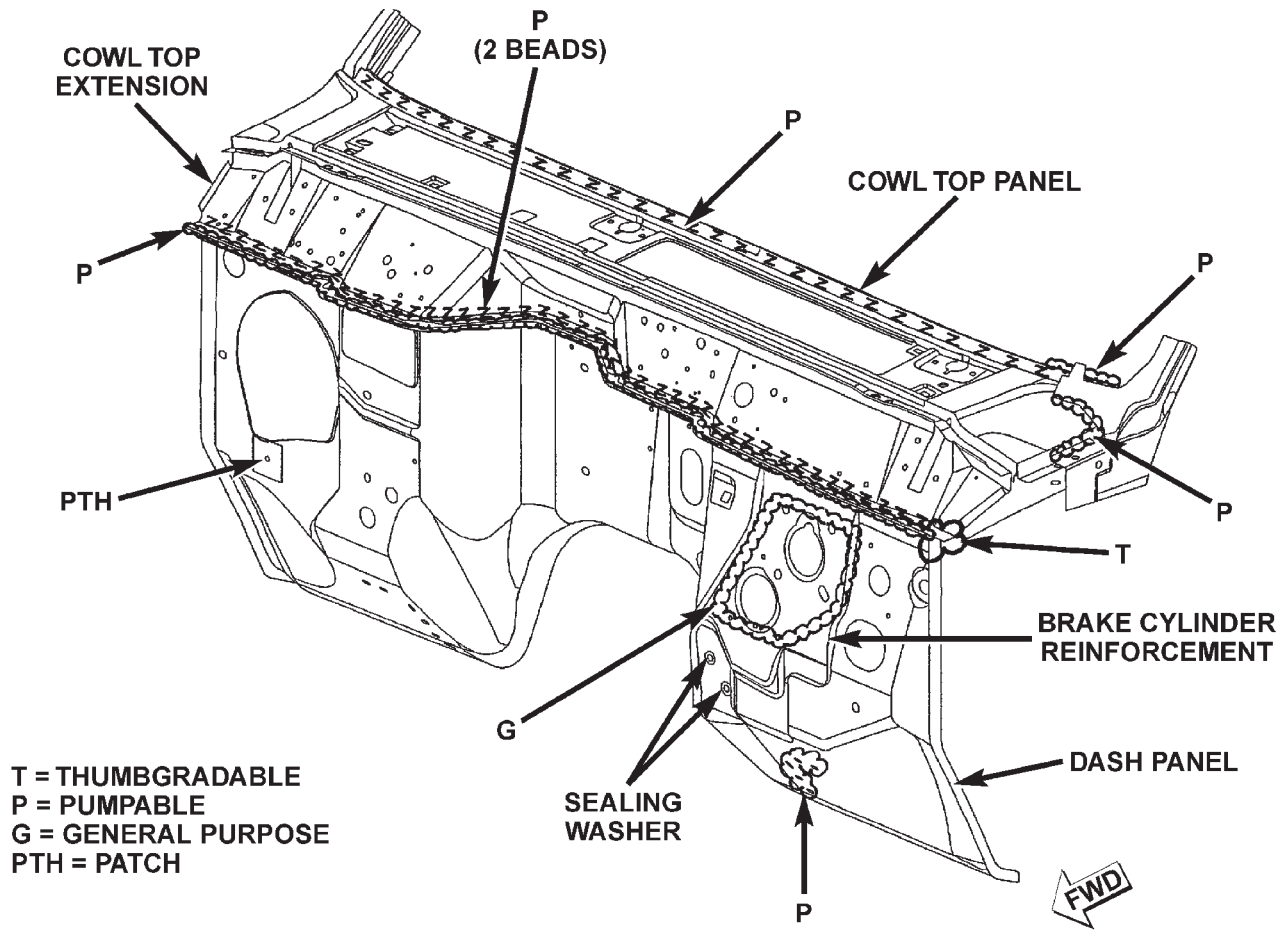

SPECIFICATIONS (Continued)

DASH PANEL AND FLOOR PAN

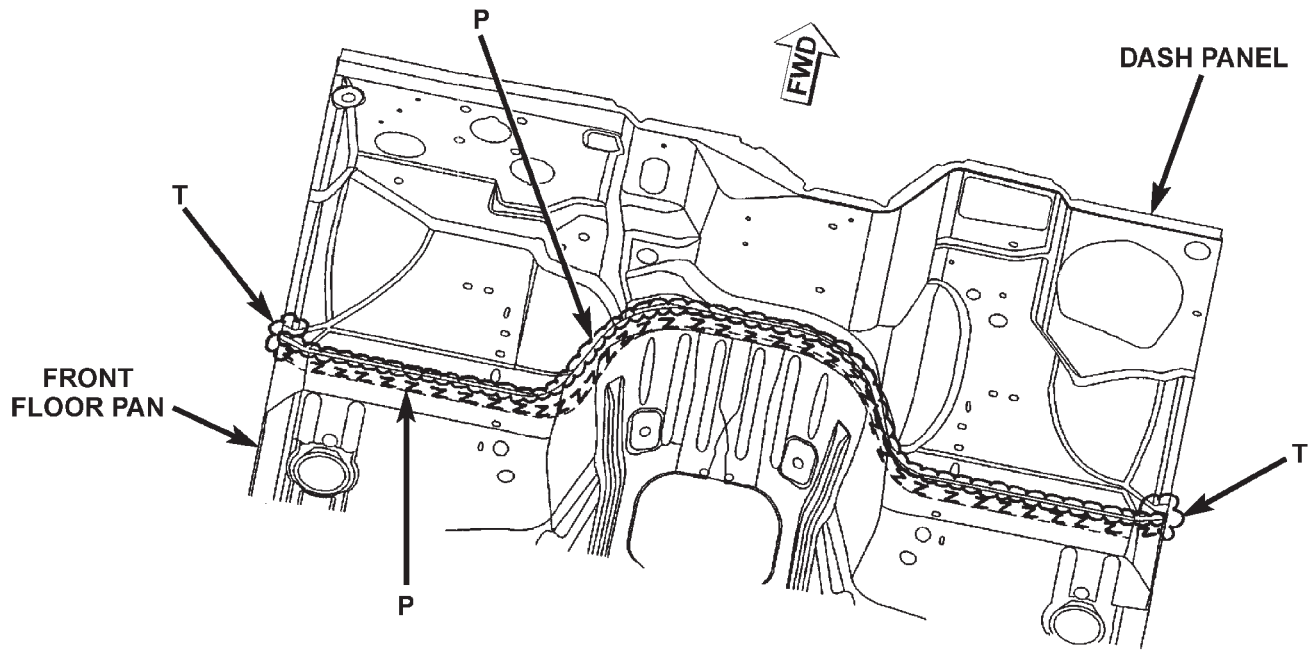

T = THUMBGRADABLE
P = PUMPABLE

SPECIFICATIONS (Continued)

FLOOR PAN

P = PUMPABLE
G = GENERAL PURPOSE

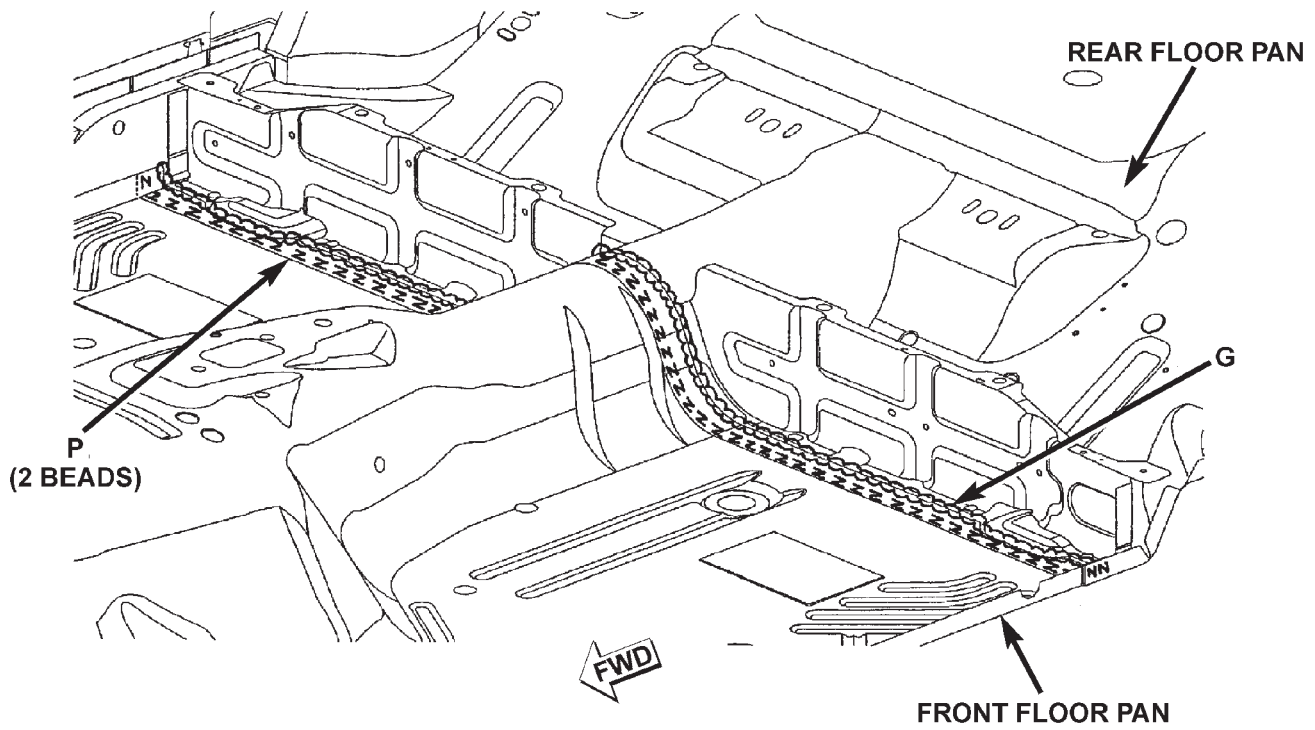
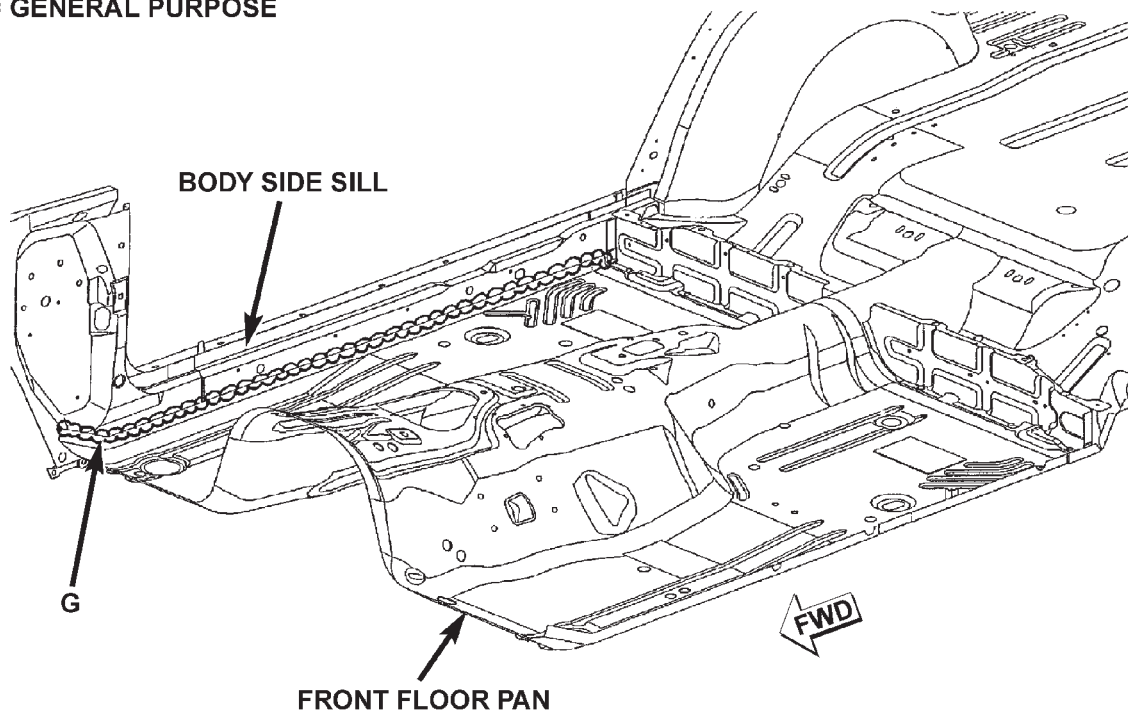

SPECIFICATIONS (Continued)

REAR INNER WHEELHOUSE

- T = THUMBGRADABLE
- P = PUMPABLE
- G = GENERAL PURPOSE

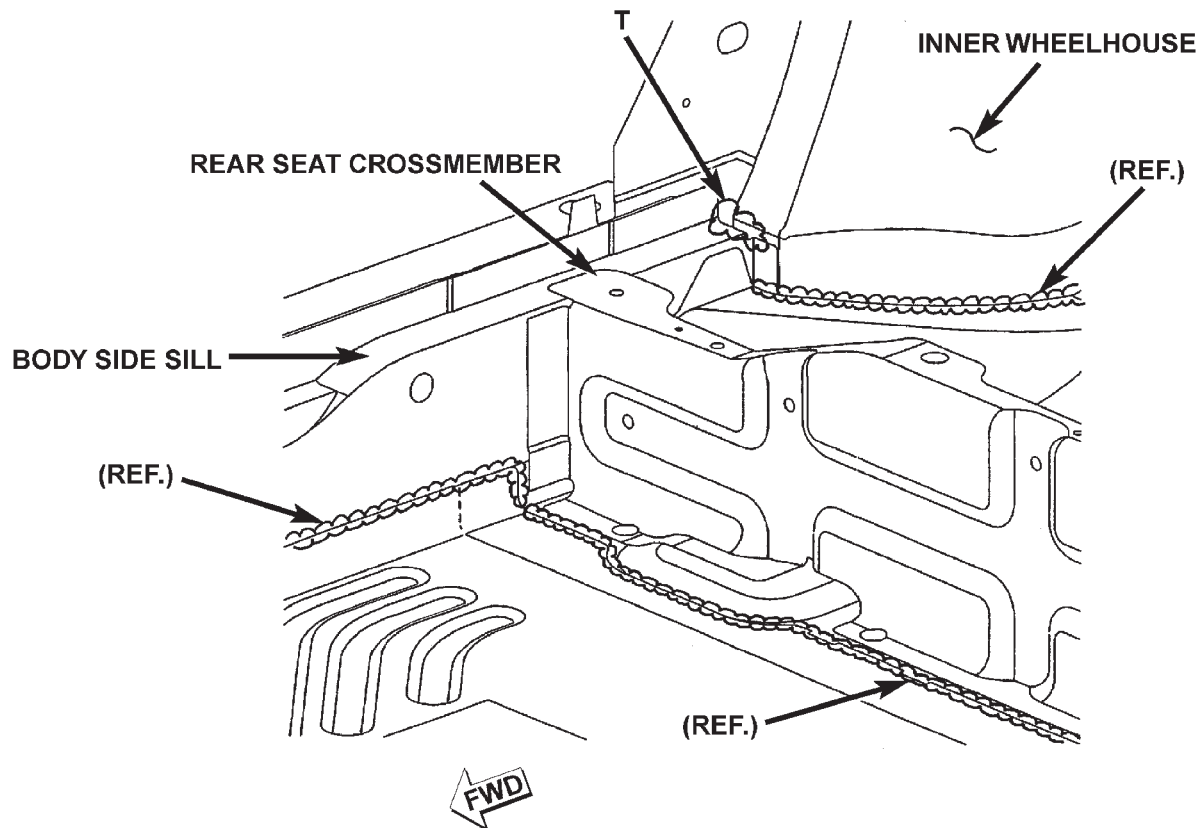
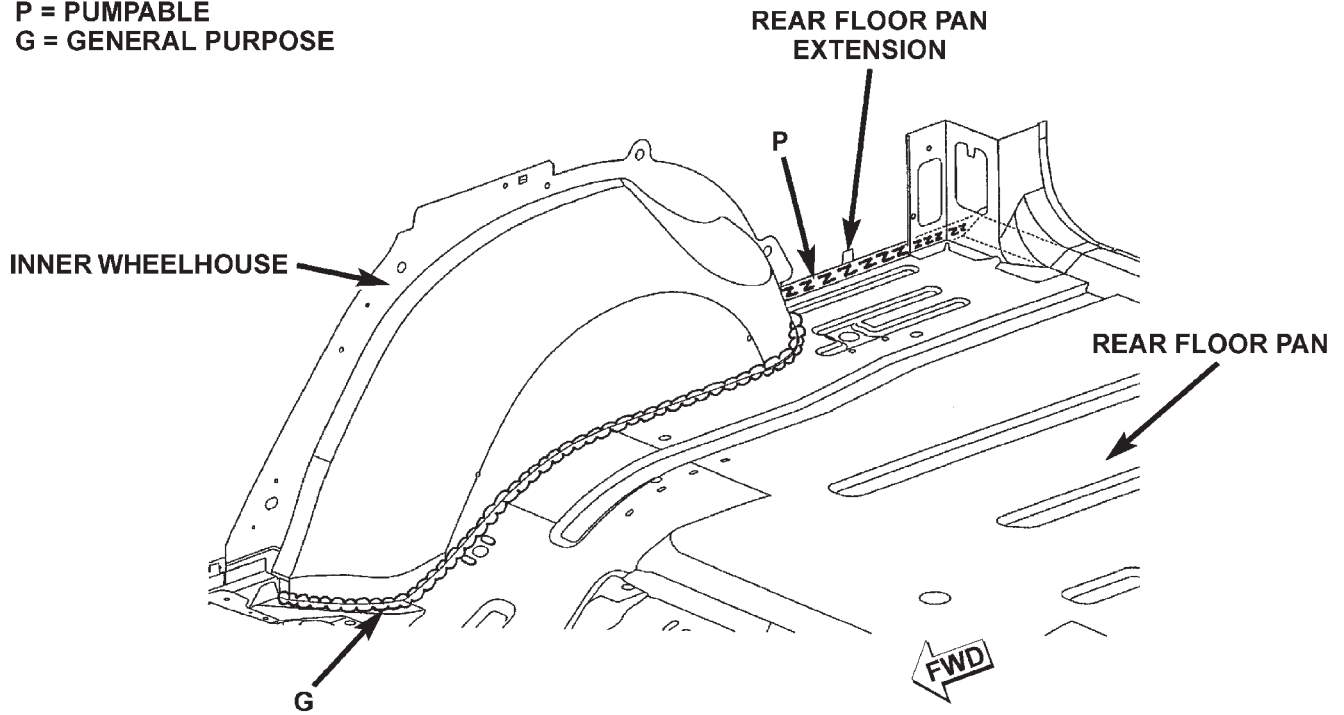

SPECIFICATIONS (Continued)

FRONT INNER WHEELHOUSE

T = THUMBGRADABLE
P = PUMPABLE

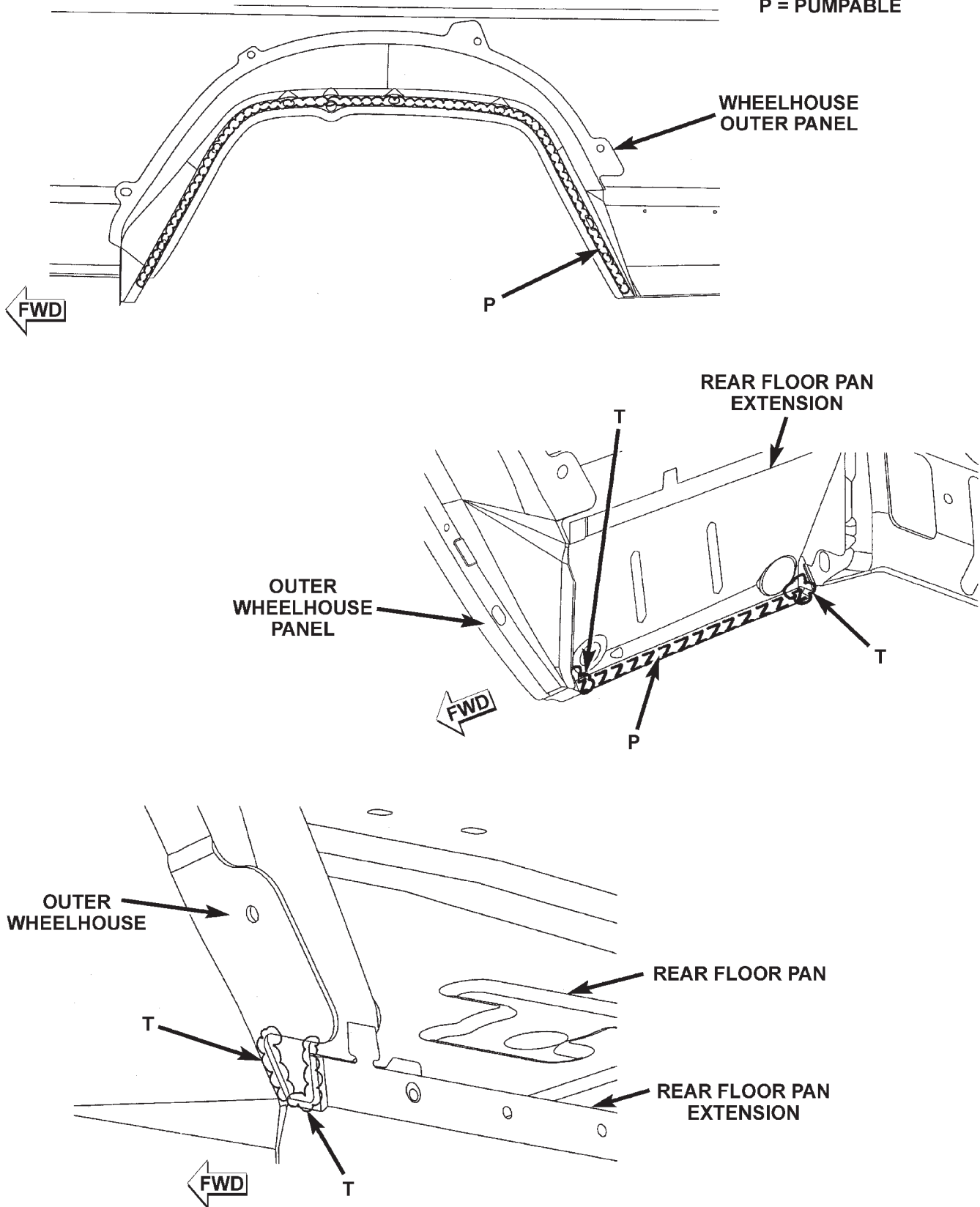

SPECIFICATIONS (Continued)

BODY SIDE

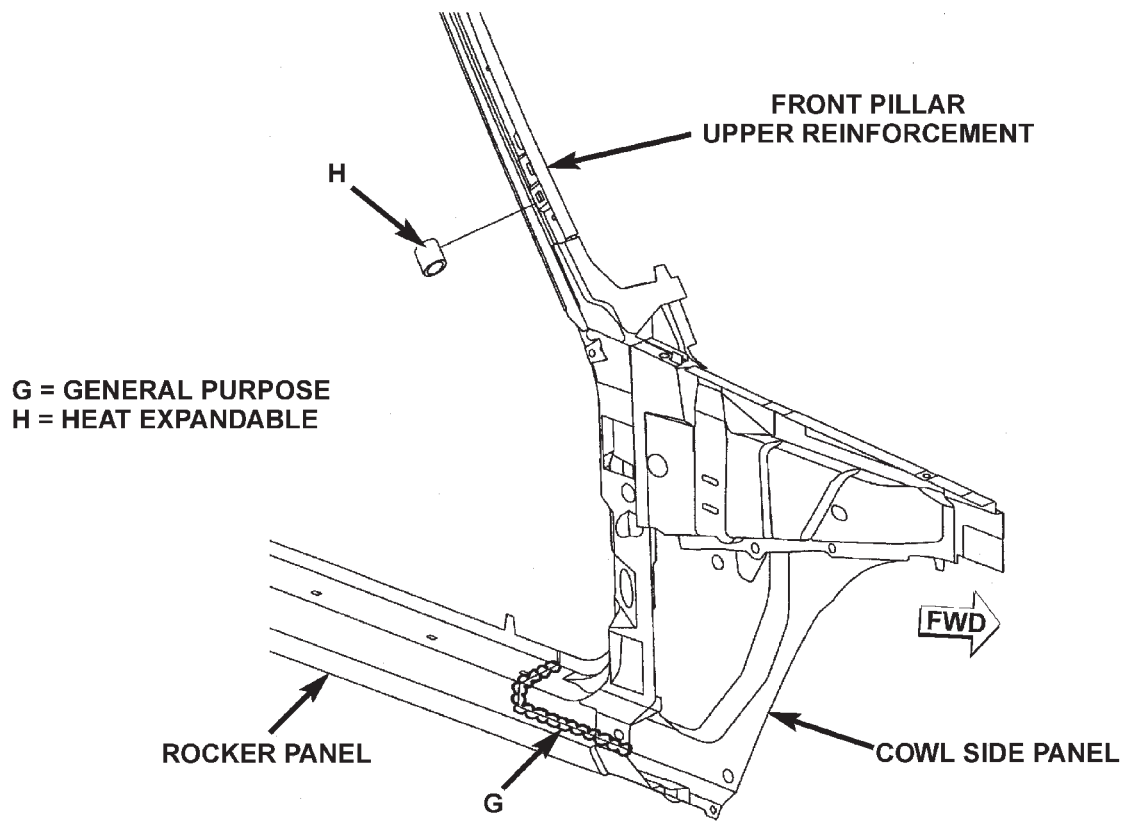

80b6fdeb

SPECIFICATIONS (Continued)

BODY SIDE

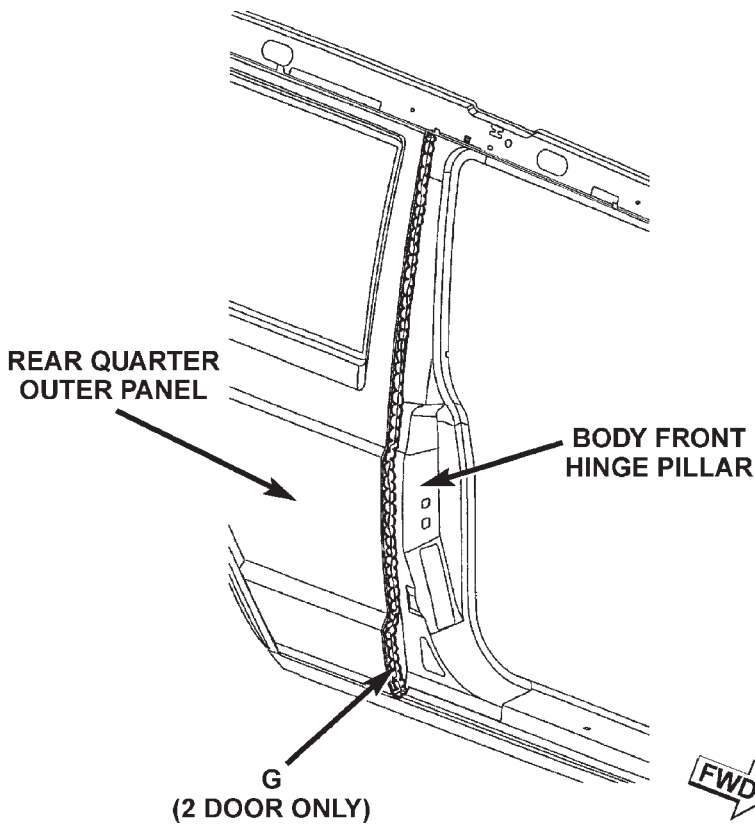
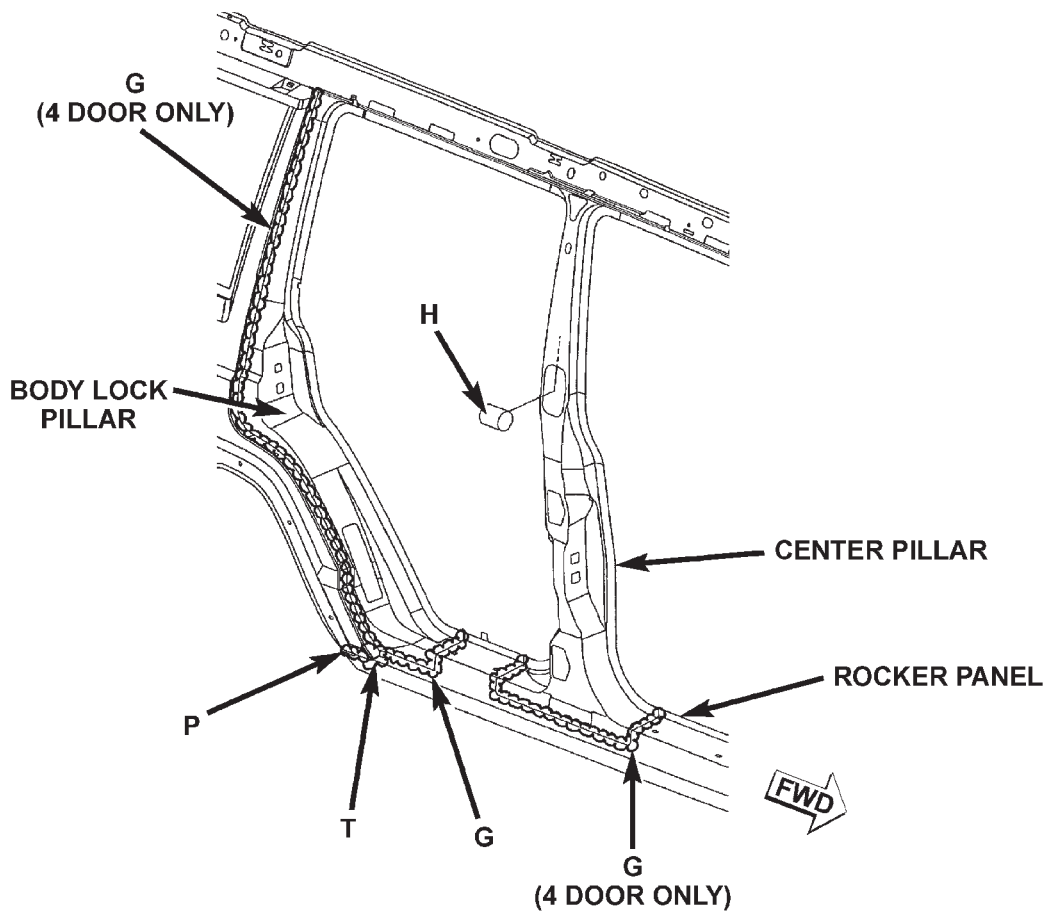

T = THUMBGRADABLE
P = PUMPABLE
G = GENERAL PURPOSE
H = HEAT EXPANDABLE

SPECIFICATIONS (Continued)

BODY SIDE

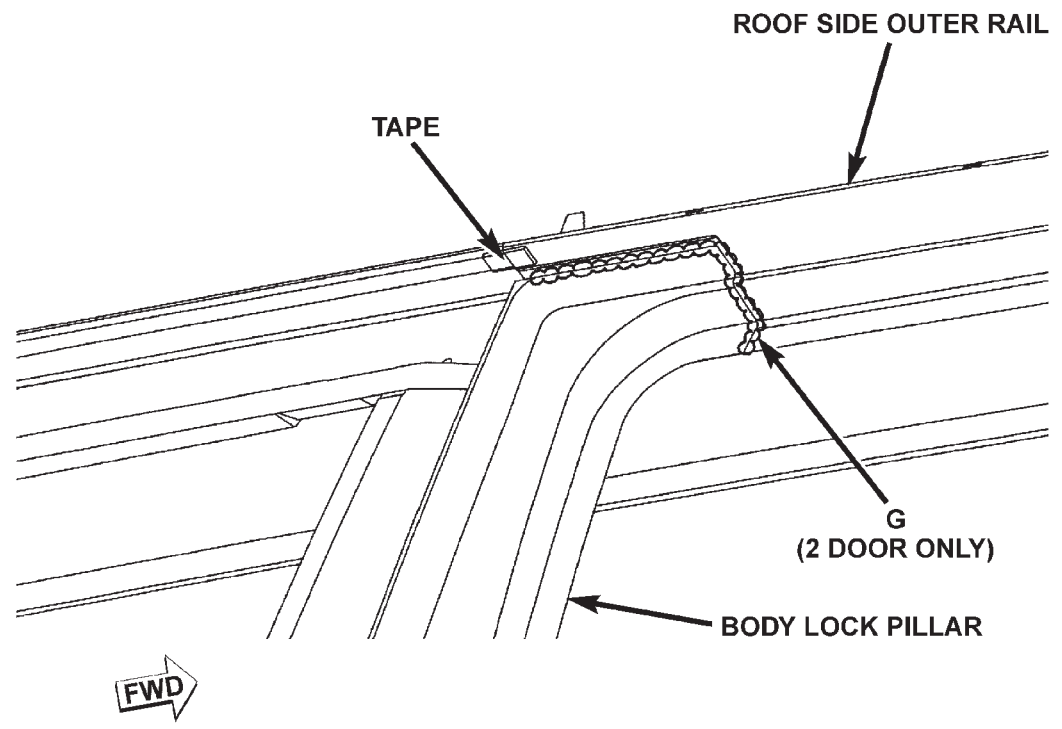
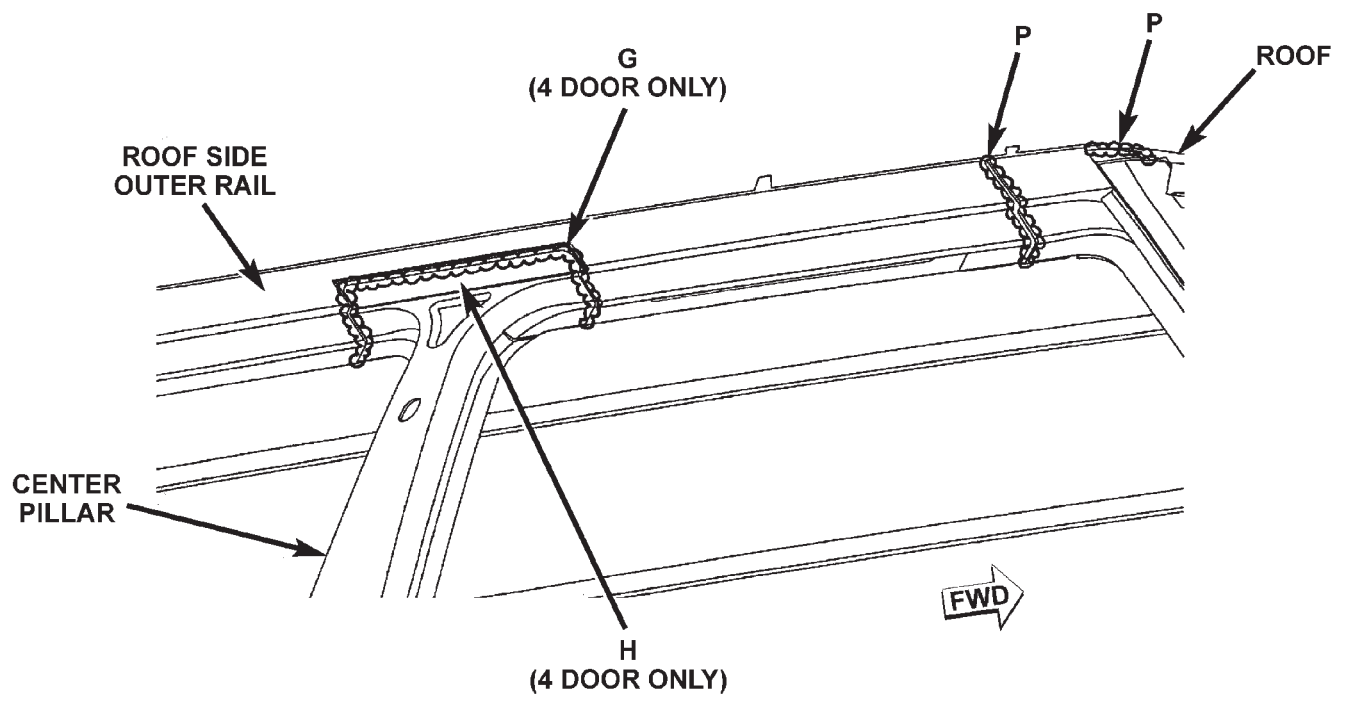

P = PUMPABLE
G = GENERAL PURPOSE
H = HEAT EXPANDABLE

SPECIFICATIONS (Continued)

ROOF PANEL

P = PUMPABLE

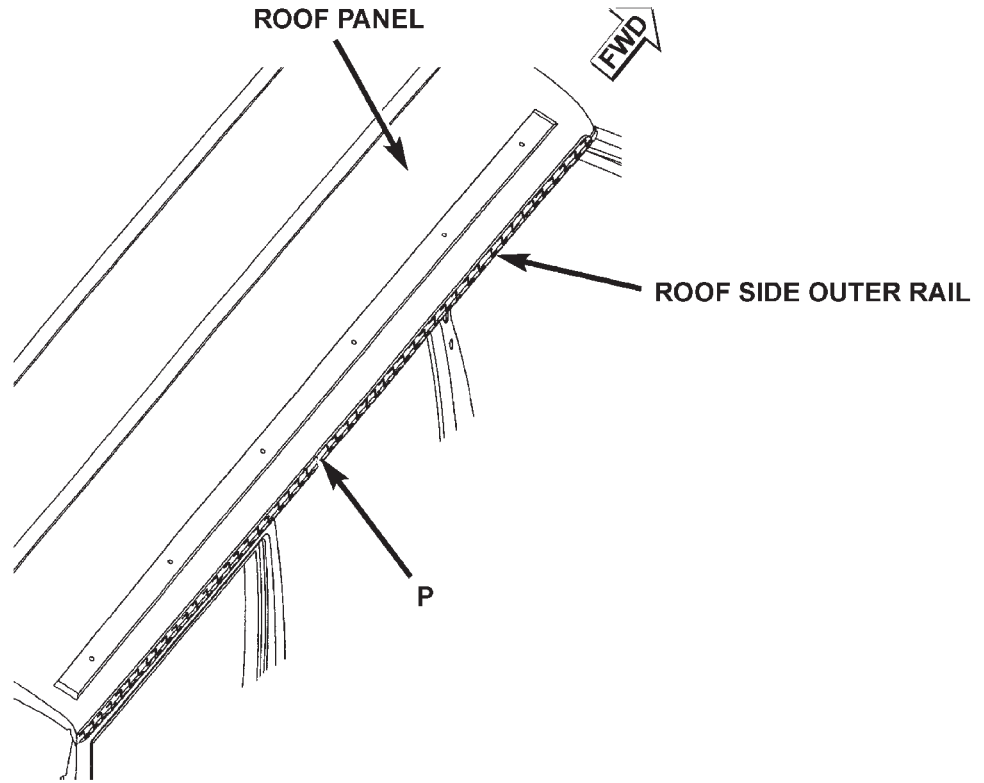

80b6fdee

SPECIFICATIONS (Continued)

FUEL FILLER HOUSING

T = THUMBGRADABLE
P = PUMPABLE

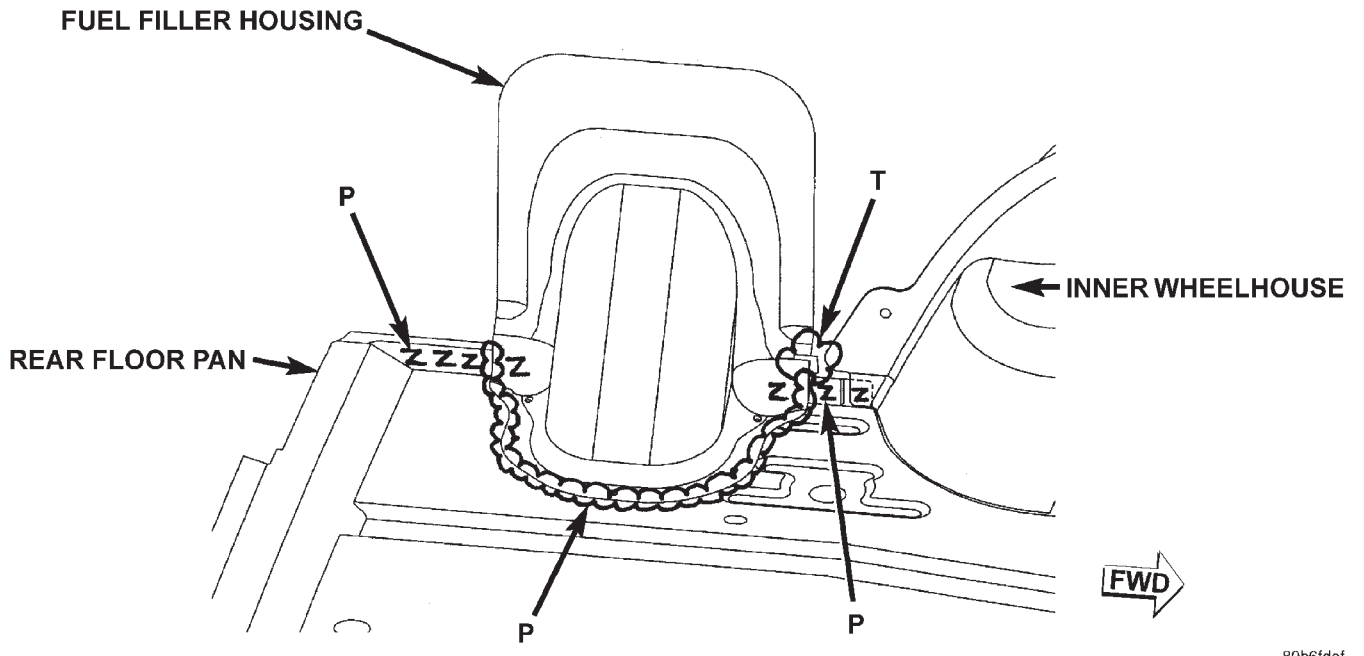
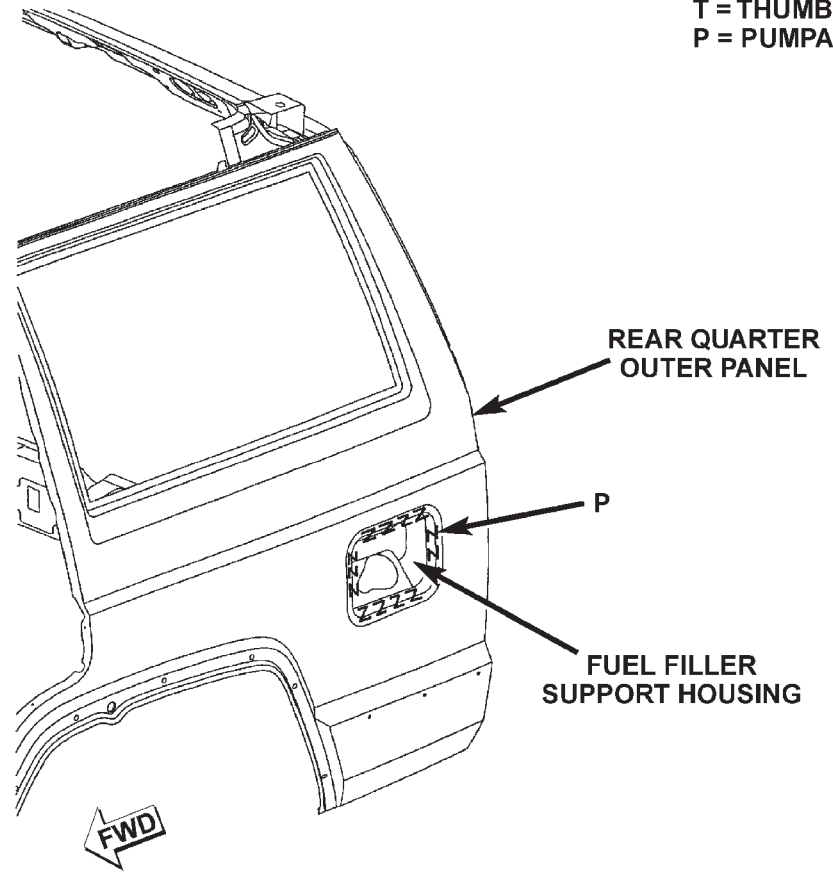

SPECIFICATIONS (Continued)

LIFTGATE OPENING

LIFTGATE HEADER
PANEL

T = THUMBGRADABLE
P = PUMPABLE

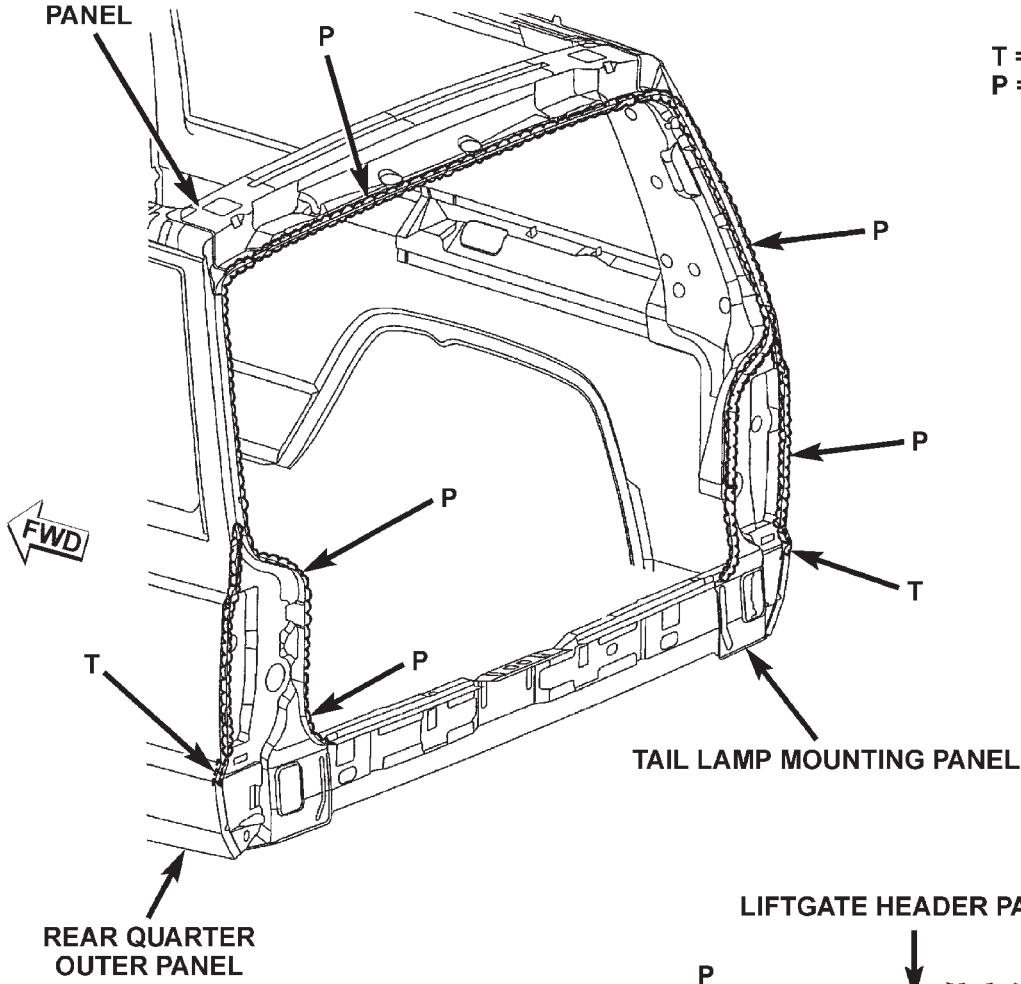

LIFTGATE HEADER
PANEL

TAPE

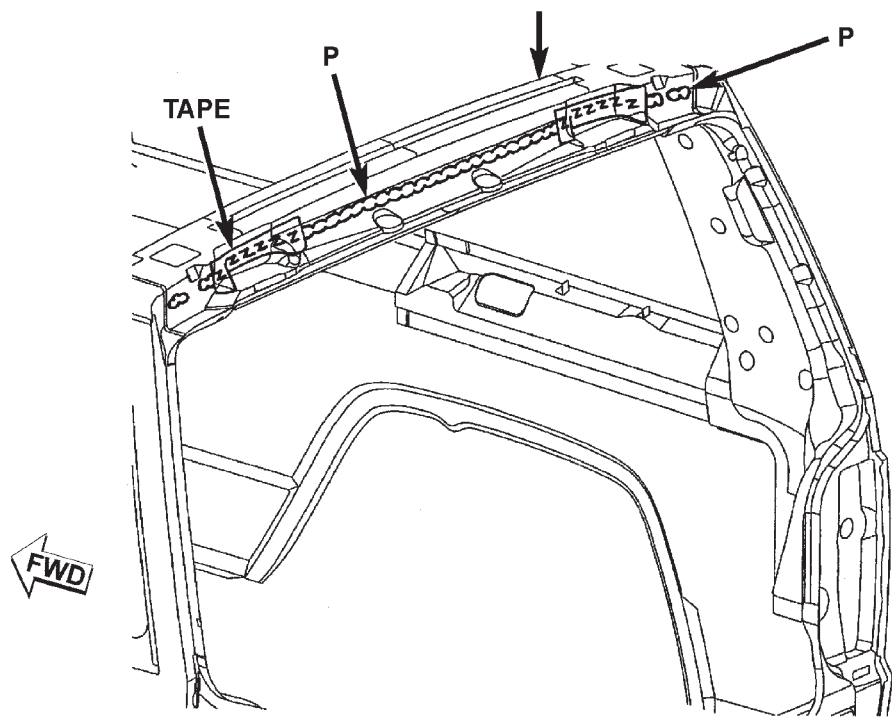

SPECIFICATIONS (Continued)

STRUCTURAL ADHESIVE LOCATIONS

LEFT QUARTER PANEL

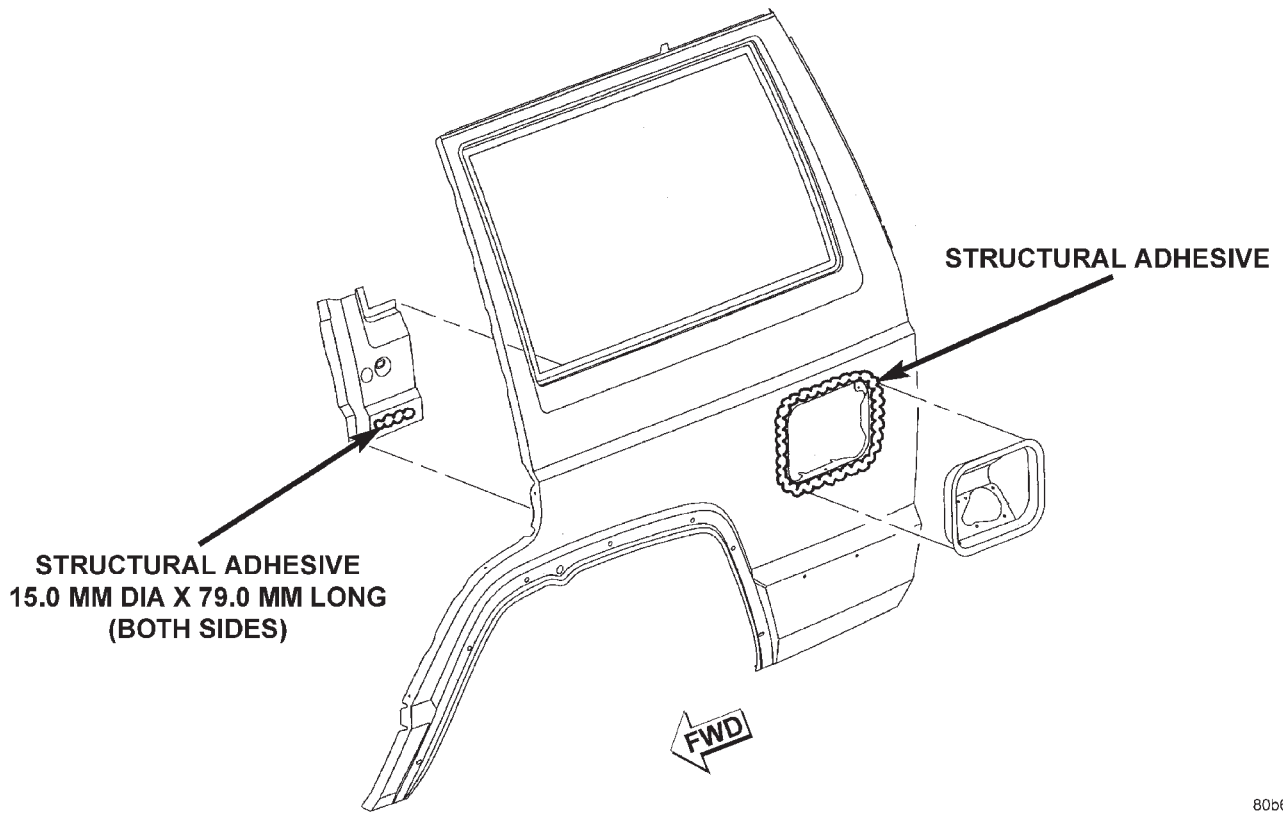

SPECIFICATIONS (Continued)

REAR WHEELHOUSE

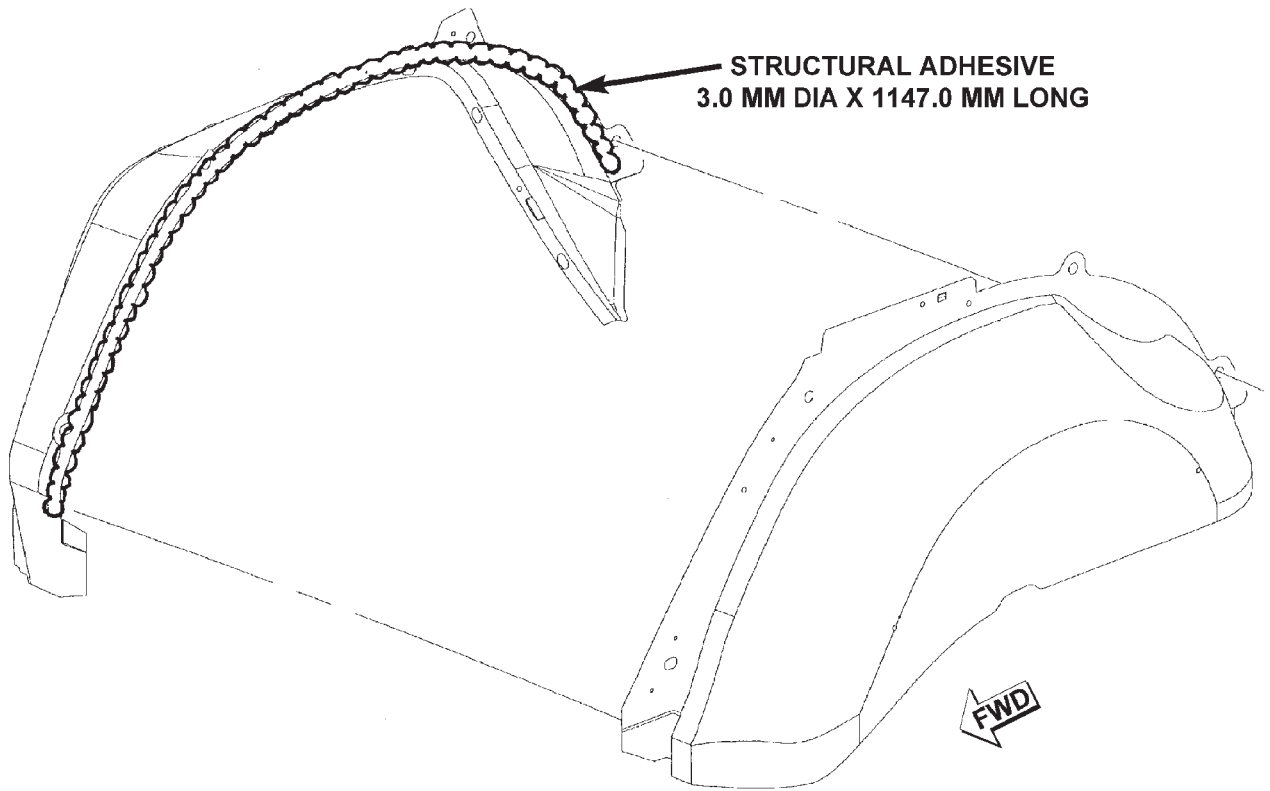

80b6fde4

SPECIFICATIONS (Continued)

ROOF BOWS

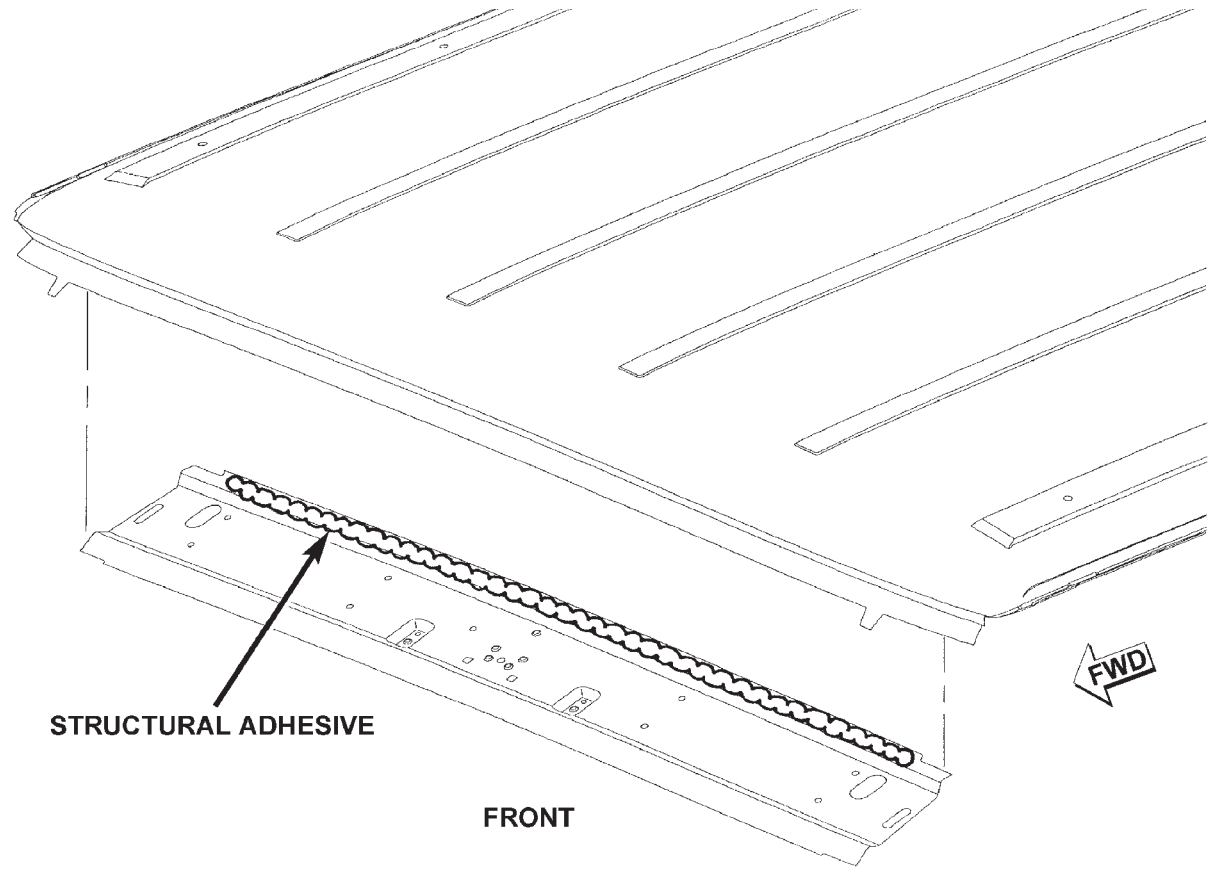

STRUCTURAL ADHESIVE

FRONT

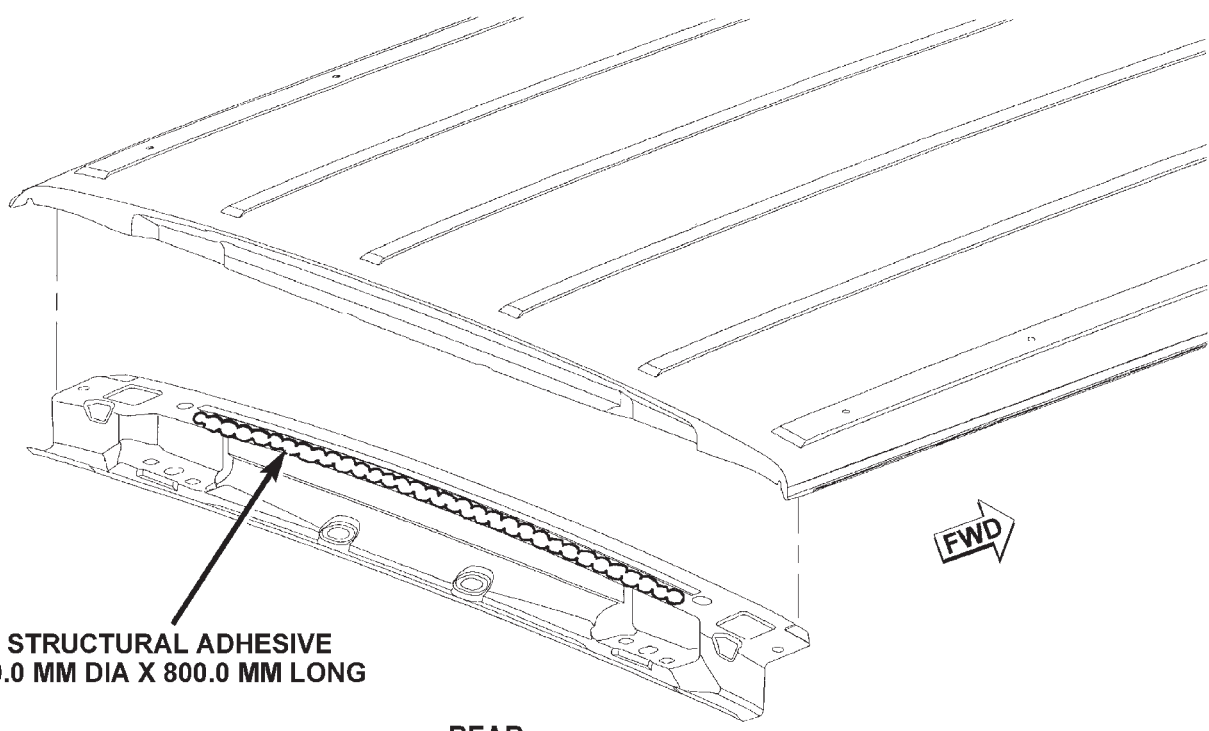

STRUCTURAL ADHESIVE
10.0 MM DIA X 800.0 MM LONG

REAR

SPECIFICATIONS (Continued)

BODY GAP AND FLUSH MEASUREMENTS

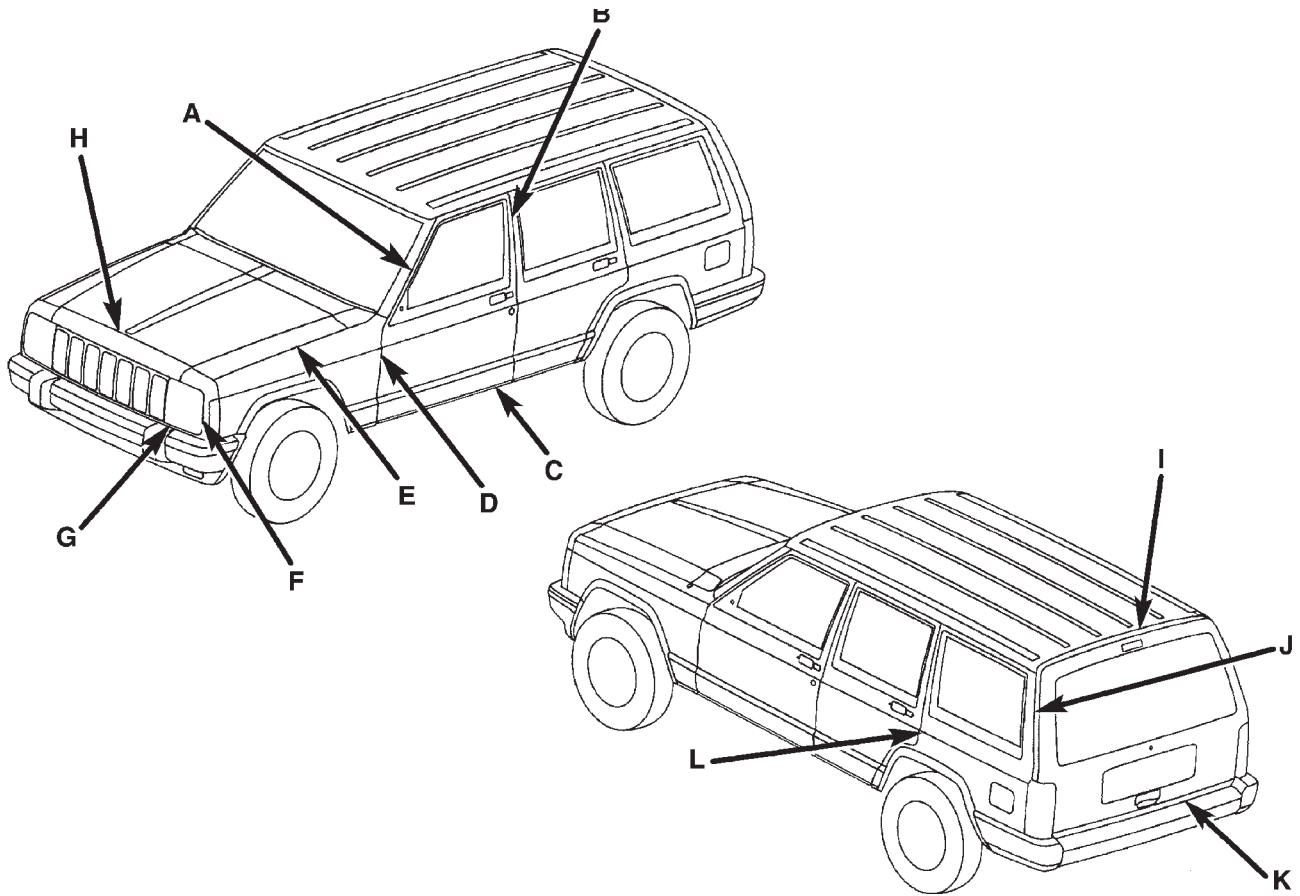

	LOCATION	GAP	FLUSH
A	Front Door to Windshield Pillar	6.4 +/- 2.0	1.6 +/- 2.0
B	Front Door to Rear Door	6.4 +/- 1.5	0.0 +/- 1.5
C	Front Door to Aperture at Sill	8.1 +/- 1.5	0.0 +/- 1.5
D	Front Door to Fender	6.4 +/- 1.5	0.0 +/- 1.5
E	Hood to Fender	5.6 +/- 1.5	0.5 +/- 1.5
F	Headlamp to Fender	5.6 +/- 1.5	0.5 +/- 1.5
G	Headlamp to Grille	N/A	0.74 +/- 1.0
H	Grille to Hood	6.0 +/- 1.5	0.24 +/- 1.5
I	Liftgate to Roof	7.5 +/- 1.5	0.5 +/- 1.5
J	Liftgate to Aperture	6.5 +/- 1.5	0.0 +/- 1.5
K	Liftgate to Fascia	X.X +/- 2.0	N/A
L	Rear Door to Quarter Panel	6.4 +/- 1.5	0.0 +/- 1.5

NOTE: ALL MEASUREMENTS ARE IN MM.

SPECIFICATIONS (Continued)

BODY OPENING DIMENSIONS

WINDSHIELD OPENING

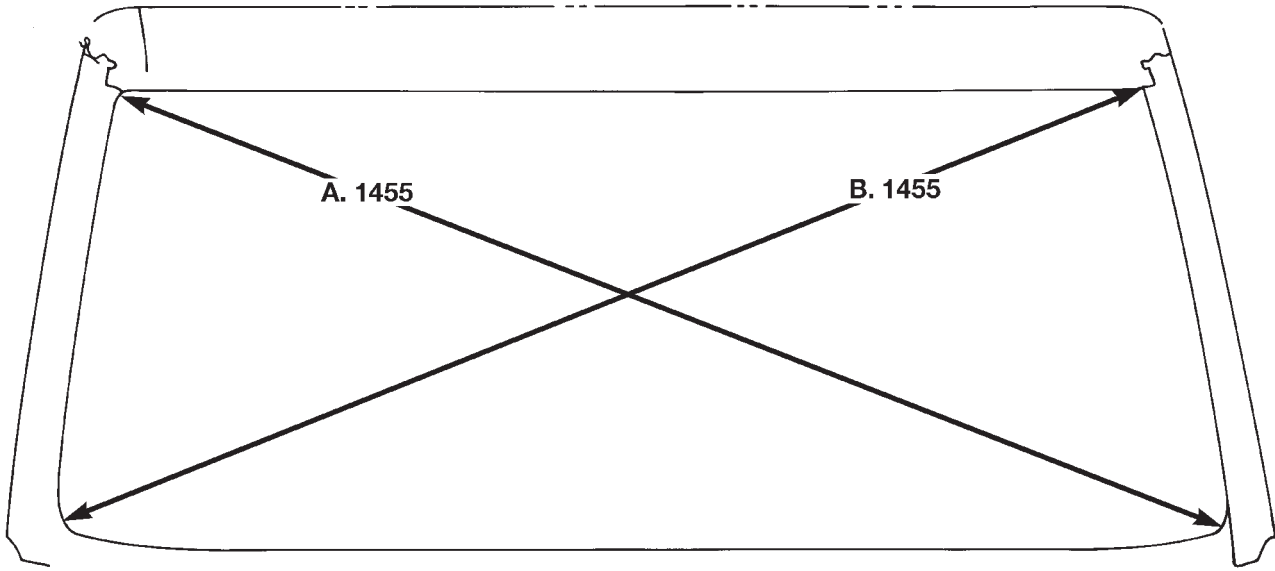

80ae834e

- A. & B. Center of radius at bottom to center of radius at top

SPECIFICATIONS (Continued)

FRONT DOOR OPENING 2-DOOR

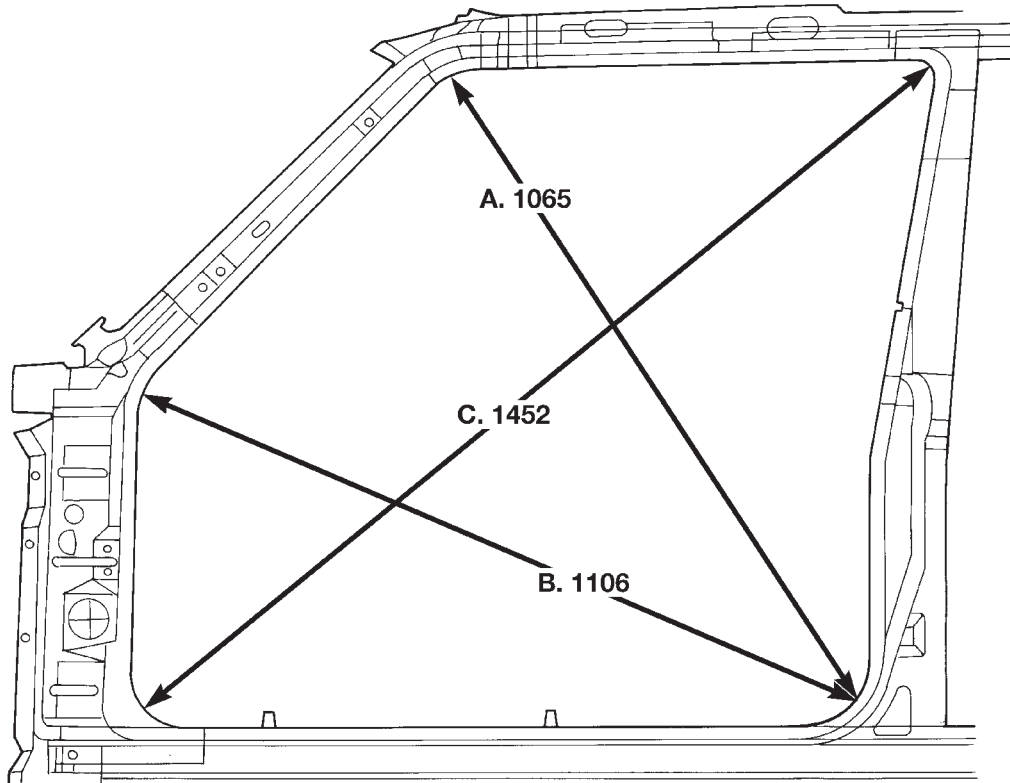

80ae834f

- A. Center of front door lower rear radius to center of A-pillar radius
- B. Center of radius at bottom rear to center of radius at lower A-pillar
- C. Center of radius at bottom front to center of radius at top rear

SPECIFICATIONS (Continued)

FRONT DOOR OPENING 4-DOOR

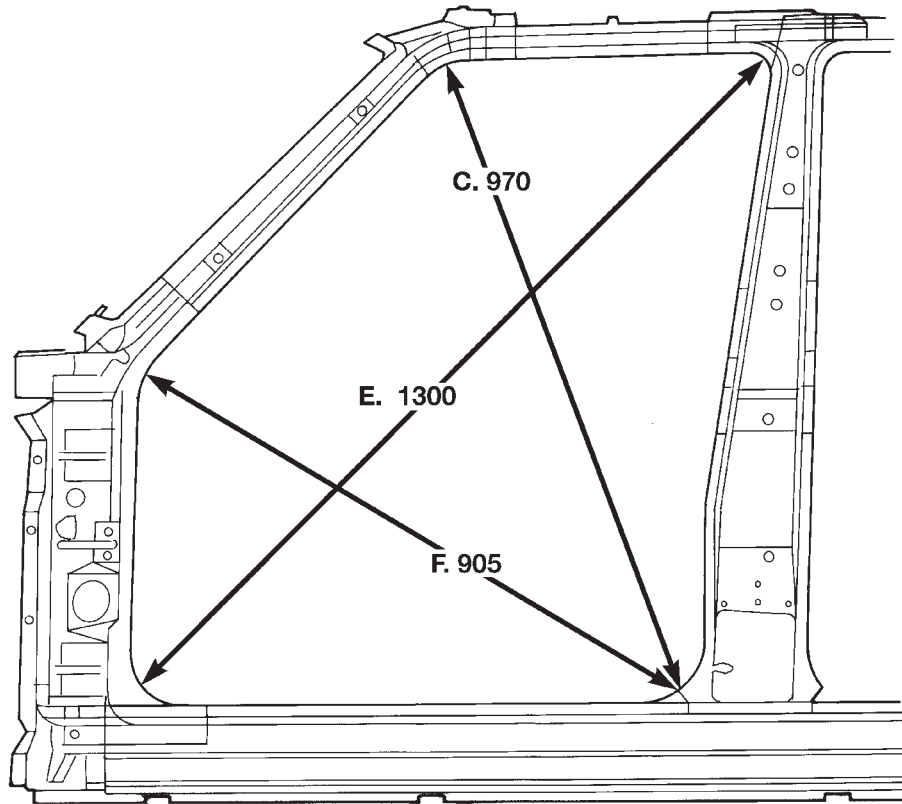

80ae8351

- C. Center of front door lower rear radius to center of A-pillar radius
- E. Center of radius at bottom rear to center of radius at lower A-pillar
- F. Center of radius at bottom front to center of radius at top rear

SPECIFICATIONS (Continued)

REAR DOOR OPENING

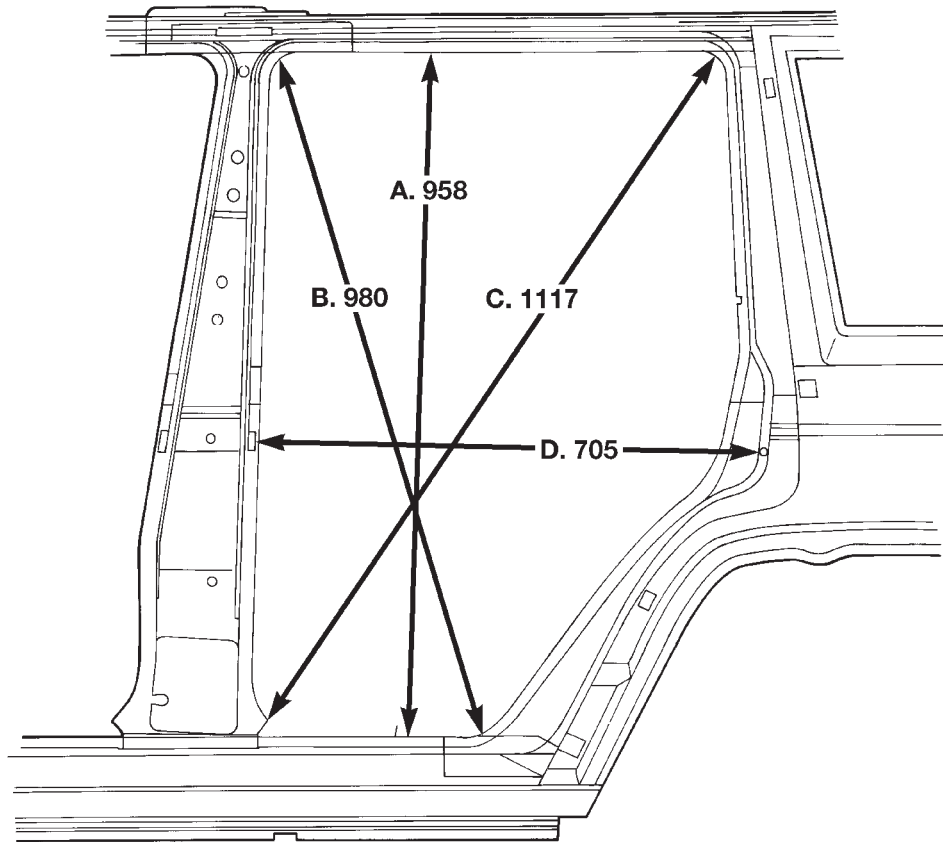

80ae8352

- A. Quarter panel to front outer body side upper and lower seam
- B. Center of front upper door radius to center of rear lower door radius
- C. Center of front lower door radius to center of rear upper door radius
- D. Flange to rear door striker mount

SPECIFICATIONS (Continued)

QUARTER WINDOW OPENING 2-DOOR

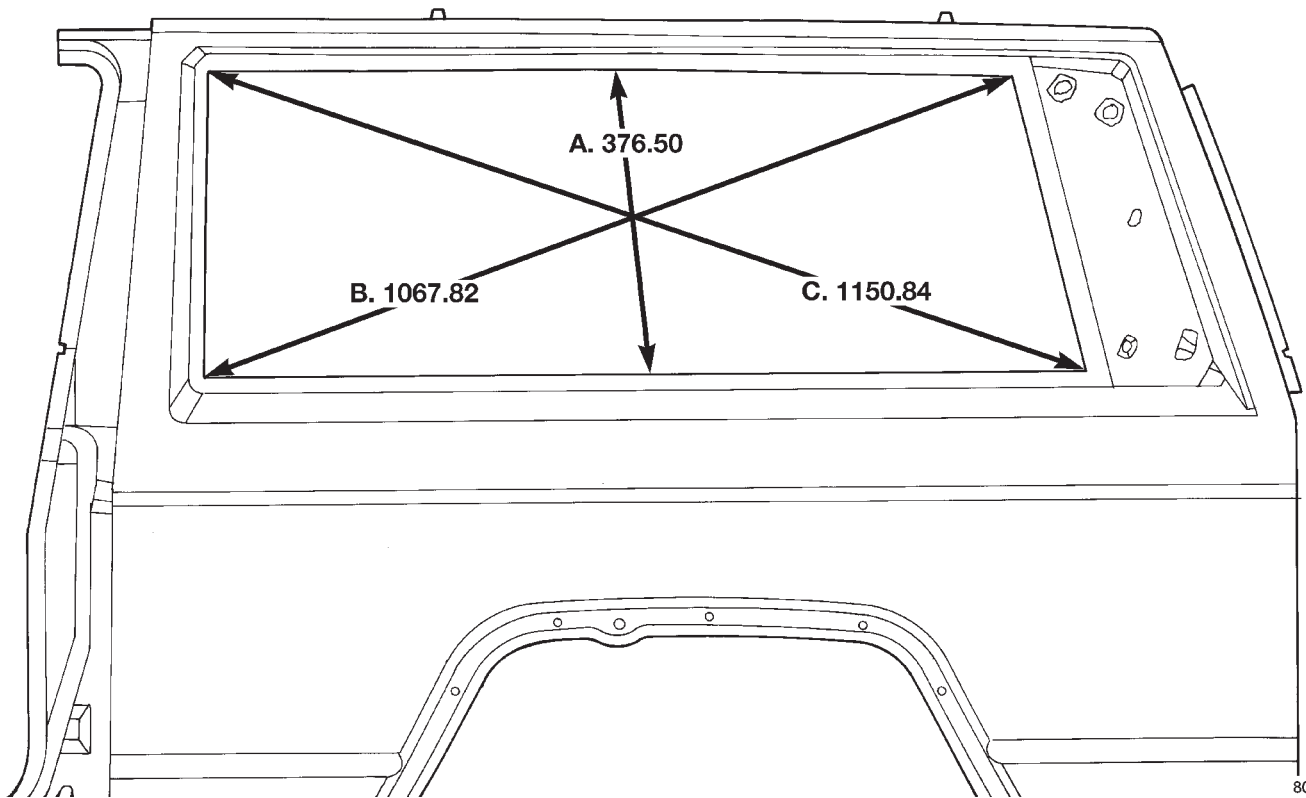

80aac308

- A. Center of upper and lower rear quarter window opening
- B. Center of radius front lower corner to center of radius rear upper corner
- C. Center of radius front upper corner to center of radius rear lower corner

SPECIFICATIONS (Continued)

QUARTER WINDOW OPENING 4-DOOR

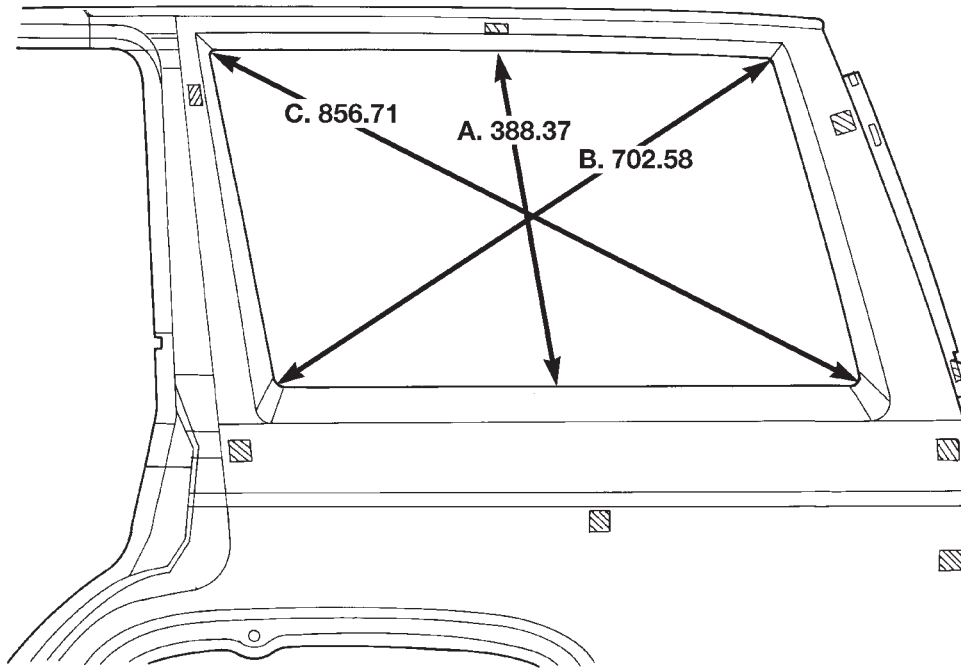

80a9f0f9

- A. Center of upper and lower rear quarter window opening
- B. Center of radius front lower corner to center of radius rear upper corner
- C. Center of radius front upper corner to center of radius rear lower corner

SPECIFICATIONS (Continued)

ENGINE COMPARTMENT

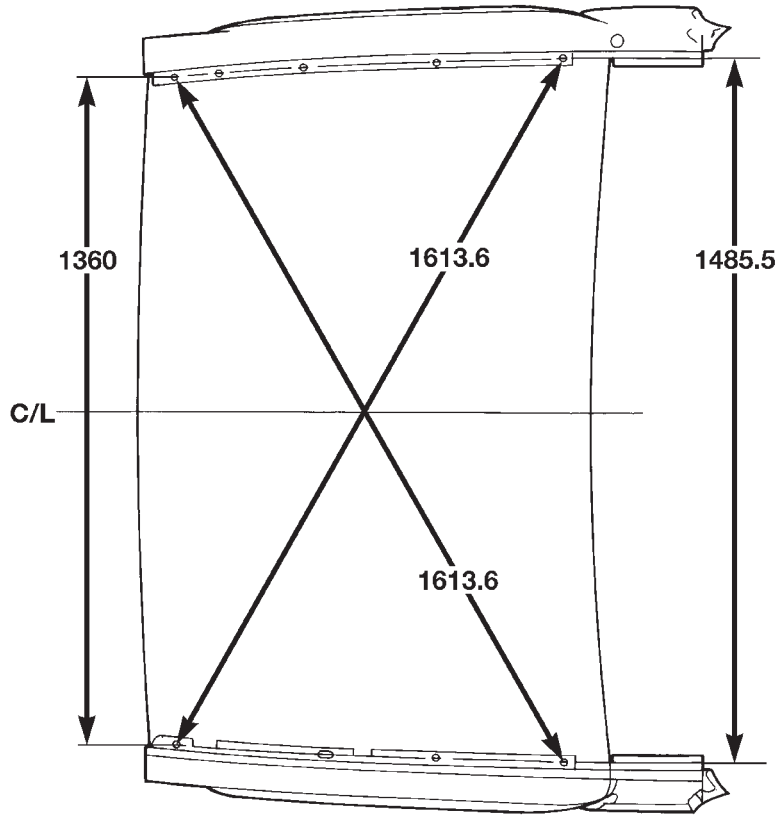

80ae8354

SPECIFICATIONS (Continued)

LIFTGATE OPENING

LIFTGATE OPENING

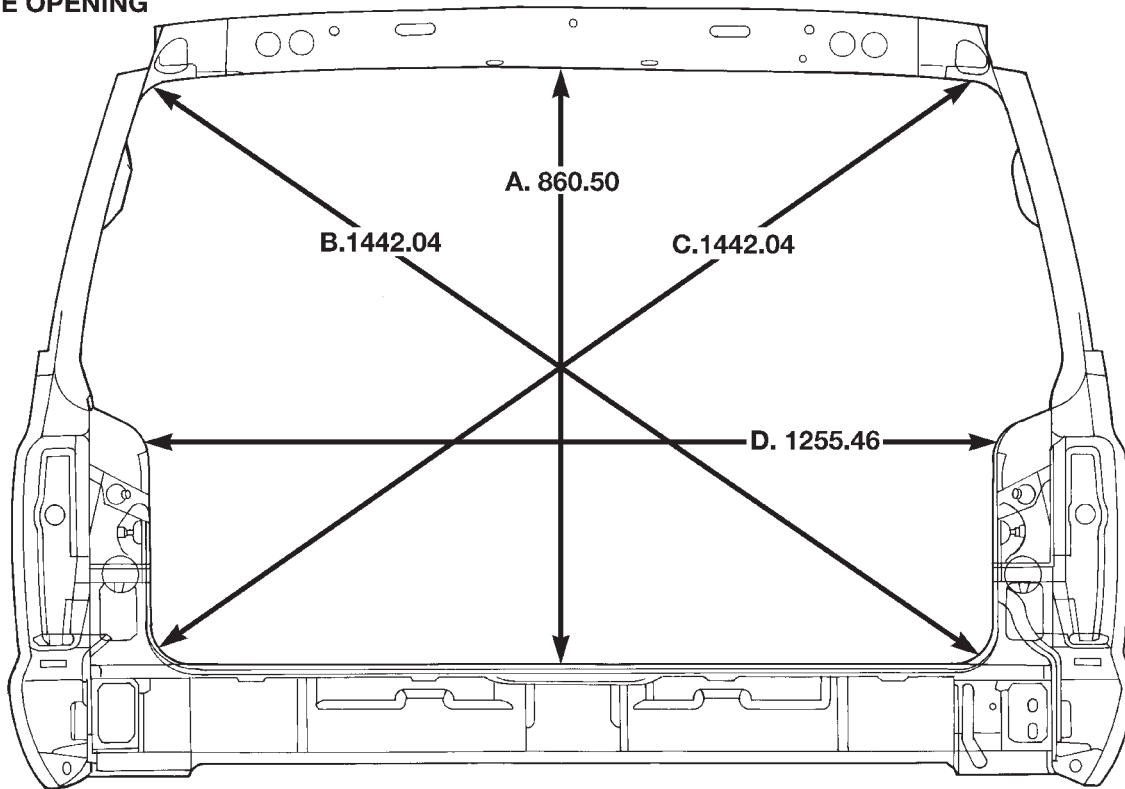

80b3c727

- A. Center of upper liftgate opening to liftgate striker mount
- B. & C. Center of radius upper corner to center of radius lower corner
- D. Distance between outer quarter panel to tail lamp mounting panel to inner quarter panel seams

TORQUE SPECIFICATIONS

DESCRIPTION	TORQUE
Bucket Seat to Floor Pan Bolt . . .	27 N·m (20 ft. lbs.)
Bucket Seat to Floor Pan Nut . . .	40 N·m (30 ft. lbs.)
Front Door Hinge Bolts	3 N·m (2 ft. lbs.)
Front Door Latch Screw	11 N·m (8 ft. lbs.)
Front Door Latch Striker Screw	28 N·m (20 ft. lbs.)
Front Seat Belt Anchor Bolt	43 N·m (32 ft. lbs.)
Front Retractor Anchor Bolt	43 N·m (32 ft. lbs.)
Front Seat Belt Buckle Anchor Bolt	43 N·m (32 ft. lbs.)
GOP to Support Bracket Nut	4 N·m (38 in. lbs.)
GOP to Fender Nut	4 N·m (38 in. lbs.)
Liftgate Hinge to Body and/or Liftgate Bolt	26 N·m (19 ft. lbs.)
Liftgate Latch Screw	13 N·m (9 ft. lbs.)
Liftgate Latch Striker Nut	54 N·m (40 ft. lbs.)

DESCRIPTION	TORQUE
Rear Door Hinge Bolt	3 N·m (2 ft. lbs.)
Rear Door Latch Screw	11 N·m (8 ft. lbs.)
Rear Door Latch Striker Screw	28 N·m (20 ft. lbs.)
Rear Shoulder Belt Lower Anchor Bolt	43 N·m (32 ft. lbs.)
Rear Seatback Pivot Bolt	33 N·m (25 ft. lbs.)
Rear Seat Belt/Buckle Anchor Bolt	43 N·m (32 ft. lbs.)
Rear Shoulder Belt Upper Anchor Bolt	43 N·m (32 ft. lbs.)

SPECIAL TOOLS

BODY

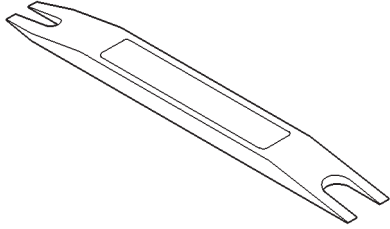

Remover, Moldings C-4829