

# EMISSION CONTROL SYSTEM

## CONTENTS

	page		page
EXHAUST EMISSION CONTROLS—2.5L DIESEL ENGINE .....	6	ON-BOARD DIAGNOSTICS—2.5L DIESEL ENGINE .....	1

## ON-BOARD DIAGNOSTICS—2.5L DIESEL ENGINE

### INDEX

	page		page
<b>GENERAL INFORMATION</b>		<b>DESCRIPTION AND OPERATION</b>	
SYSTEM DESCRIPTION—2.5L DIESEL ENGINE .	1	DIAGNOSTIC TROUBLE CODES .....	2

### GENERAL INFORMATION

#### SYSTEM DESCRIPTION—2.5L DIESEL ENGINE

The 2.5L diesel Engine Control Module (ECM) and Powertrain Control Module (PCM) monitor and control many different circuits in the fuel injection pump and engine systems. If the ECM senses a problem with a monitored circuit that indicates an actual problem, a Diagnostic Trouble Code (DTC) will be stored in the PCM's memory, and eventually may illuminate the Check Engine Lamp constantly while the key is on. If the problem is repaired, or is intermittent, the ECM will erase the DTC after 40 warm-up cycles. A warm-up cycle consists of starting the vehicle when the engine is cold, then the engine to warms up to a certain temperature, and finally, the engine temperature falls to a normal operating temperature, then the key is turned off.

Certain criteria must be met for a DTC to be entered into ECM memory. The criteria may be a specific range of engine rpm, engine or fuel temperature and/or input voltage to the ECM. A DTC indicates that the ECM has identified an abnormal signal in a circuit or the system. A DTC may indicate the result of a failure, but never identify the failed component directly.

There are several operating conditions that the ECM does not monitor and set a DTC for. Refer to the following Monitored Circuits and Non-Monitored Circuits in this section.

### ECM MONITORED SYSTEMS

The ECM can detect certain problems in the electrical system.

**Open or Shorted Circuit** – The ECM will not distinguish between an open or a short to ground, however the ECM can determine if sensor output (which is the input to ECM) is within proper range. It also determines if the circuit is open or shorted.

**Output Device Current Flow** – The ECM senses whether the output devices are electrically connected.

If there is a problem with the circuit, the ECM senses whether the circuit is open, shorted to ground (-), or shorted to (+) voltage.

### ECM NON-MONITORED SYSTEMS

The ECM does not monitor the following circuits, systems or conditions that could have malfunctions that result in driveability problems. A DTC will not be displayed for these conditions.

**Fuel Pressure:** Fuel pressure is controlled by the fuel injection pump. The ECM cannot detect fuel pressure problems in this component. The ECM does a comparison analysis of fuel quantity, fuel timing, fuel temperature, and control sleeve sensor inputs to determine if a fuel problem exists.

**Cylinder Compression:** The ECM cannot detect uneven, low, or high engine cylinder compression.

**Exhaust System:** The ECM cannot detect a plugged, restricted or leaking exhaust system.

**Fuel Injector Malfunctions:** The ECM cannot determine if the fuel injector is clogged, or the wrong injector is installed. The fuel injectors on the diesel engine are **not controlled** by the ECM, although a

## GENERAL INFORMATION (Continued)

defective fuel injector sensor **is monitored** by the ECM.

**Vacuum Assist:** Leaks or restrictions in the vacuum circuits of vacuum assisted engine control system devices are not monitored by the ECM.

**ECM System Ground:** The ECM cannot determine a poor system ground. However, a DTC may be generated as a result of this condition.

**ECM/PCM Connector Engagement:** The ECM cannot determine spread or damaged connector pins. However, a DTC may be generated as a result of this condition.

## HIGH AND LOW LIMITS

The ECM compares input signals from each input device. It will establish high and low limits that are programmed into it for that device. If the inputs are not within specifications and other DTC criteria are met, a DTC will be stored in memory. Other DTC criteria might include engine rpm limits or input voltages from other sensors or switches. The other inputs might have to be sensed by the ECM when it senses a high or low input voltage from the control system device in question.

## DESCRIPTION AND OPERATION

## DIAGNOSTIC TROUBLE CODES

On the following pages, a list of DTC's is provided for the 2.5L diesel engine. A DTC indicates that the ECM has recognized an abnormal signal in a circuit

or the system. A DTC may indicate the result of a failure, but most likely will not identify the failed component directly.

## ACCESSING DIAGNOSTIC TROUBLE CODES

A stored DTC can be displayed through the use of the DRB III® scan tool. The DRB III® connects to the data link connector. The data link connector is located under the instrument panel near bottom of the steering column (Fig. 1).

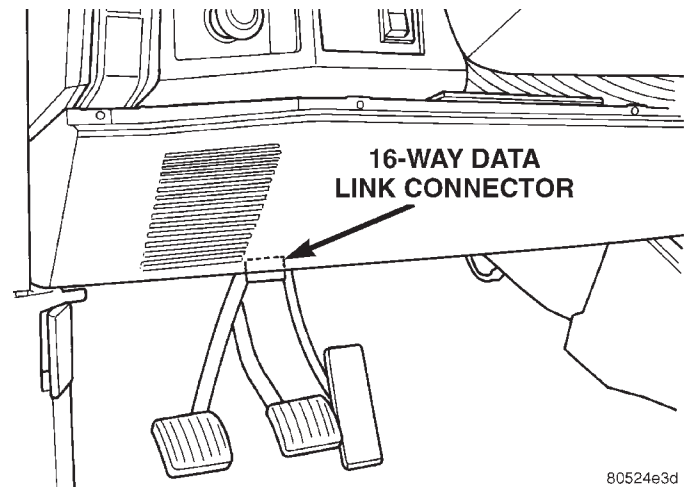

80524e3d

*Fig. 1 Data Link Connector Location—Typical*

## ERASING TROUBLE CODES

After the problem has been repaired, use the DRB III® scan tool to erase a DTC.

## DESCRIPTION AND OPERATION (Continued)

## MSA CONTROLLER DRBIII® CODES

Generic Scan Tool Code	DRB III® Scan Tool Display
P0115	Temperature of Engine Coolant SRC High Exceeded Temperature of Engine Coolant SRC Low Exceeded
P0180	Fuel Temperature Sensor SRC High Exceeded Fuel Temperature Sensor SRC Low Exceeded
P0235	Turbocharger Boost Sensor Signal High Exceeded Turbocharger Boost Sensor Signal Low Exceeded Turbocharger Boost Sensor Supply High Exceeded Turbocharger Boost Sensor Supply High Exceeded Turbocharger Boost Sensor Plausibility
P0400	EGR Open Circuit EGR Short Circuit
P0500	Veh. Speed Sensor PEC Frequency Too High Veh. Speed Sensor SRC High Exceeded Veh. Speed Sensor Plausibility
P0725	Engine Speed Sensor Dyn. Plausibility Engine Speed Sensor Over Speed Recognition Engine Speed Sensor Static Plausibility
P1105	Atmosphere Pressure Sensor SRC High Exceeded Atmosphere Pressure Sensor SRC Low Exceeded
P1110	Air Temp. Sensor SRC High Exceeded Air Temp. Sensor SRC Low Exceeded
P1201	Needle Movement Sensor SRC High Exceeded Needle Movement Sensor SRC Low Exceeded
P1220	Fuel Quantity Actuator Neg Gov Deviation Cold Fuel Quantity Actuator Neg Gov Deviation Warm Fuel Quantity Actuator Pos Gov Deviation Cold Fuel Quantity Actuator Pos Gov Deviation Warm
P1225	Control Sleeve Sensor Signal High Exceeded Control Sleeve Sensor Start End Pos. Not Attained Control Sleeve Sensor Stop End Pos. Not Attained
P1230	Timing Governing Negative Governor Deviation Timing Governing Positive Governor Deviation
P1515	Accel. Pedal Sensor Signal High Exceeded Accel. Pedal Sensor Supply SRC High Exceeded Accel. Pedal Sensor Supply SRC Low Exceeded Accel. Pedal Sensor Plausibility

## DESCRIPTION AND OPERATION (Continued)

Generic Scan Tool Code	DRB III® Scan Tool Display
P1520	Vehicle Speed Gov Analog Ctrl Control Contact Alone
P1600	Battery Voltage SRC High Exceeded
P1605	Terminal #15 Plausibility After Startup
P1610	Regulator Lower Regulator Limit Regulator Upper Regulator Limit
P1615	Microcontroller Gate-Array Monitoring Microcontroller Gate-Array Watchdog Microcontroller Prepare Fuel Quantity Stop Microcontroller Recovery Was Occurred Microcontroller Redundant Overrun Monitoring
P1620	U_REF (2.5V)
P1630	Solenoid Valve Controller Open Circuit Solenoid Valve Controller Short Circuit
P1635	Glow Relay Controller Open Circuit Glow Relay Controller Short Circuit
P1660	Redundant Emer. Stop Plausibility In After-Run Redundant Emer. Stop Powerstage Defective
P1680	EEPROM Plausibility Checksum Error for Adj. EEPROM Plausibility Checksum Error in CC212 EEPROM Plausibility Communication With EEPROM EEPROM Plausibility Func. Switch Wrong or Missing EEPROM Plausibility VIN Checksum Error
P1685	Vehicle Theft Alarm Immobilizer Signal Lost Vehicle Theft Alarm Invalid SKIM Message
P1690	Fan Control Open Circuit Fan Control Short Circuit
P1695	AC Control Short Circuit AC Control OpenCircuit
P1703	Brake Signal Plaus With Redundant Contact
P1725	Inductive Aux. Speed Sensor Dynamic Plausibility Inductive Aux. Speed Sensor Overspeed Recognition Inductive Aux Speed Sensor Plausibility Inductive Aux. Speed Sensor Static Plausibility

## DESCRIPTION AND OPERATION (Continued)

## PCM DRBIII® CODES

Generic Scan Tool Code	DRBIII Scan Tool Display
P0117	Engine Coolant Volts Low
P0118	Engine Coolant Volts High
P0462	Fuel Level Sending Unit volts Too Low
P0463	Fuel Level Sending Unit volts Too High
P0500	Vehicle Speed Signal
P0522	Oil Pressure Sense Low
P0523	Oil Pressure Sense High
P0601	Internal Controller Failure
P0622	Generator Field Not Switching Properly
P1296	5 VDC Output
P1391	Loss of Cam or Crank
P1492	Ambient/Batt temp Sen Volts Too High
P1493	Ambient/Batt temp Sen Volts Too Low
P1594	Charging System Voltage Too High
P1682	Charge Output Low
P1685	SKIM Invalid Key
P1686	No SKIM Bus Message Recieved
P1687	No MIC Bus Message
P1696	PCM Failure EEPROM Write Denied

# EXHAUST EMISSION CONTROLS—2.5L DIESEL ENGINE

## INDEX

	page		page
<b>DESCRIPTION AND OPERATION</b>		<b>REMOVAL AND INSTALLATION</b>	
EXHAUST GAS RECIRCULATION (EGR) SYSTEM .....	6	EGR TUBE .....	8
VACUUM HOSE ROUTING SCHEMATIC .....	6	EGR VALVE .....	7
<b>DIAGNOSIS AND TESTING</b>		ELECTRIC VACUUM MODULATOR (EVM) .....	8
EGR GAS FLOW TEST .....	7	<b>SPECIFICATIONS</b>	
EGR SOLENOID TEST .....	7	TORQUE CHART—2.5L DIESEL .....	8

## DESCRIPTION AND OPERATION

### VACUUM HOSE ROUTING SCHEMATIC

Vacuum for the EGR system is supplied by the internal engine mounted vacuum pump. Refer to EGR System Operation for vacuum pump information. Vacuum harness routing for emission related components is displayed in (Fig. 1).

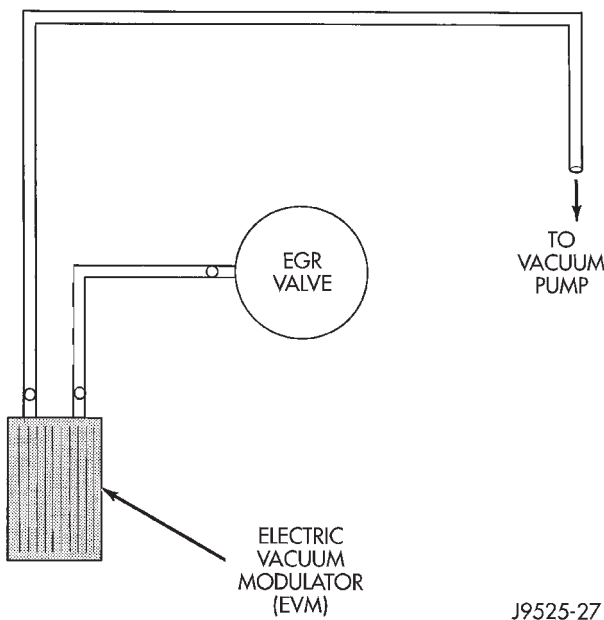

Fig. 1 Typical Hose Routing

## EXHAUST GAS RECIRCULATION (EGR) SYSTEM

### GENERAL INFORMATION

The EGR system reduces oxides of nitrogen (NOx) in the engine exhaust. This is accomplished by allow-

ing a predetermined amount of hot exhaust gas to recirculate and dilute the incoming fuel/air mixture.

A malfunctioning EGR system can cause engine stumble, sags or hesitation, rough idle, engine stalling and poor driveability.

### EGR SYSTEM OPERATION

The system consists of:

- An EGR valve assembly. The valve is located behind the intake manifold (Fig. 2).

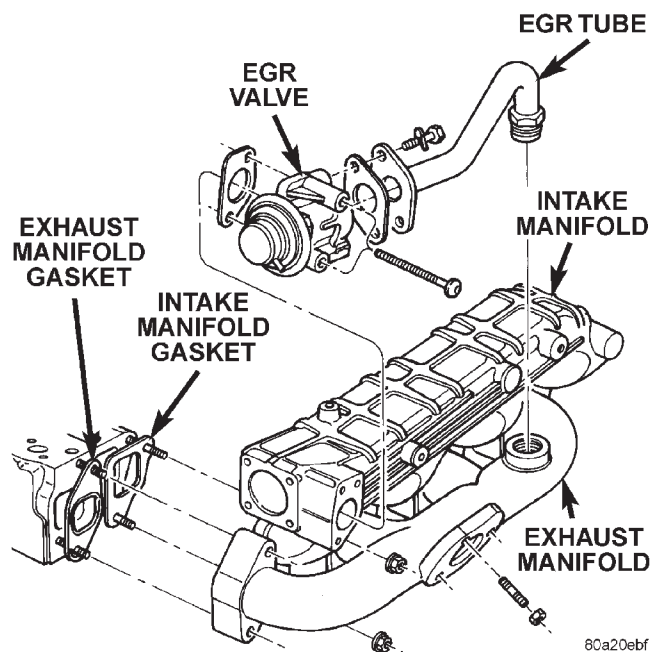

Fig. 2 EGR Valve and Tube Location

- An Electric Vacuum Modulator (EVM). The EVM is sometimes referred to as the EGR control solenoid or EGR duty cycle solenoid. The EVM serves two different functions. One is to control vacuum bleed-off of the EGR valve. The other is to control the "on time" of the EGR valve.

- The ECM operates the EVM. The ECM is located inside the vehicle in the center console.



## DESCRIPTION AND OPERATION (Continued)

- An EGR tube (Fig. 2) connecting a passage in the EGR valve to the rear of the exhaust manifold.
- The vacuum pump supplies vacuum for the EVM and the EGR valve. This pump also supplies vacuum for operation of the power brake booster. The pump is located internally in the front of the engine block (Fig. 3) and is driven by the crankshaft gear.

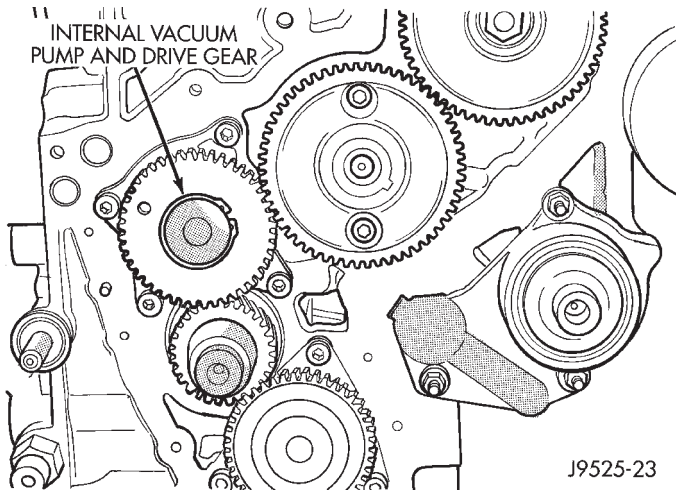

**Fig. 3 Internal Vacuum Pump**

- Vacuum lines and hoses to connect the various components.

When the ECM supplies a variable ground signal to the EVM, EGR system operation starts to occur. The ECM will monitor and determine when to supply and remove this variable ground signal. This will depend on inputs from the engine coolant temperature, throttle position and engine speed sensors.

When the variable ground signal is supplied to the EVM, vacuum from the vacuum pump will be allowed to pass through the EVM and on to the EGR valve with a connecting hose.

Exhaust gas recirculation will begin in this order when:

- The ECM determines that EGR system operation is necessary.
- The engine is running to operate the vacuum pump.
- A variable ground signal is supplied to the EVM.
- Variable vacuum passes through the EVM to the EGR valve.
- The inlet seat (poppet valve) at the bottom of the EGR valve opens to dilute and recirculate exhaust gas back into the intake manifold.

The EGR system will be shut down by the ECM after 60 seconds of continuous engine idling to improve idle quality.

## DIAGNOSIS AND TESTING

## EGR GAS FLOW TEST

Refer to the 1998 XJ/ZG Diesel Powertrain Diagnostic Manual for complete test procedure.

## EGR SOLENOID TEST

## VACUUM TEST

With the engine running, disconnect the vacuum supply line at the fitting on the EGR Solenoid. Minimum vacuum should be no less than 20 inches. If vacuum is lower, check for leaks in vacuum supply line. If leaks cannot be found, check for low vacuum at vacuum pump. Refer to Group 5, Brake System for procedures.

## REMOVAL AND INSTALLATION

## EGR VALVE

## REMOVAL

- (1) Remove the rubber hose from turbocharger to metal tube.
- (2) Disconnect vacuum line at EGR valve vacuum supply fitting (Fig. 2).
- (3) Loosen the tube fitting at exhaust manifold end of EGR tube (Fig. 2).
- (4) Remove the two bolts retaining the EGR tube to the side of EGR valve (Fig. 2).
- (5) Remove the two EGR valve mounting bolts (Fig. 2) and remove EGR valve.
- (6) Discard both of the old EGR mounting gaskets.

## INSTALLATION

- (1) Clean the intake manifold of any old gasket material.
- (2) Clean the end of EGR tube of any old gasket material.
- (3) Position the EGR valve and new gasket to the intake manifold.
- (4) Install two EGR valve mounting bolts. Do not tighten bolts at this time.
- (5) Position new gasket between EGR valve and EGR tube.
- (6) Install two EGR tube bolts. Tighten all four mounting bolts to 23 N·m (204 in. lbs.).
- (7) Tighten EGR tube fitting at exhaust manifold.
- (8) Connect vacuum line to EGR valve.
- (9) Install the rubber hose from turbocharger to metal tube.

## REMOVAL AND INSTALLATION (Continued)

**EGR TUBE**

The EGR tube connects the EGR valve to the rear of the exhaust manifold (Fig. 2).

**REMOVAL**

- (1) Remove rubber hose from turbocharger to metal tube.
- (2) Remove two EGR tube mounting bolts at EGR valve end of tube (Fig. 2).
- (3) Loosen fitting at exhaust manifold end of tube (Fig. 2).
- (4) Remove EGR tube and discard old gasket.
- (5) Clean gasket mating surfaces and EGR tube flange gasket surfaces.
- (6) Check for signs of leakage or cracked surfaces at both ends of tube, exhaust manifold and EGR valve.

**INSTALLATION**

- (1) Install a new gasket to EGR valve end of EGR tube.
- (2) Position EGR tube to engine.
- (3) Loosely tighten fitting at exhaust manifold end of tube.
- (4) Install 2 mounting bolts at EGR valve end of tube. Tighten bolts to 23 N·m (204 in. lbs.) torque.
- (5) Tighten fitting at exhaust manifold end of tube.
- (6) Install hose from turbocharger to metal tube.

**ELECTRIC VACUUM MODULATOR (EVM)**

The EVM (EGR Duty Cycle Purge Solenoid) is mounted behind the PCM.

**REMOVAL**

- (1) Disconnect the negative battery cable.
- (2) Disconnect two vacuum hoses at EVM.
- (3) Remove mounting screws of EVM.
- (4) Remove the EVM to gain access to the EVM electrical connector.
- (5) Remove electrical connector at EVM.

**INSTALLATION**

- (1) Install electrical connector to EVM.
- (2) Install EVM and tighten mounting screws.
- (3) Connect vacuum hoses.
- (4) Connect the negative battery cable.

**SPECIFICATIONS****TORQUE CHART—2.5L DIESEL**

<b>Description</b>	<b>Torque</b>
EGR Valve Mounting Bolts . . .	23 N·m (204 in. lbs.)
EGR Tube Mounting Bolts . . . .	23 N·m (204 in. lbs.)
EGR Solenoid Mounting Bolt . . . .	2 N·m (20 in. lbs.)