

# BRAKES

## CONTENTS

	page		page
BASE BRAKE SYSTEM .....	1	ANTILOCK BRAKES .....	30

## BASE BRAKE SYSTEM

### INDEX

	page		page
<b>GENERAL INFORMATION</b>		<b>REMOVAL AND INSTALLATION</b>	
BRAKE SYSTEM .....	2	STOP LAMP SWITCH .....	14
SERVICE WARNINGS & CAUTIONS .....	2	BRAKE PEDAL .....	14
<b>DESCRIPTION AND OPERATION</b>		COMBINATION VALVE .....	14
BRAKE PEDAL .....	2	MASTER CYLINDER .....	15
STOP LAMP SWITCH .....	2	POWER BRAKE BOOSTER .....	15
RED BRAKE WARNING LAMP .....	2	FRONT DISC BRAKE CALIPER .....	16
POWER BRAKE BOOSTER .....	2	FRONT DISC BRAKE SHOES .....	18
MASTER CYLINDER .....	3	DISC BRAKE ROTOR .....	19
COMBINATION VALVE .....	4	DRUM BRAKE SHOES .....	19
FRONT DISC BRAKES .....	4	WHEEL CYLINDER .....	20
REAR DRUM BRAKE .....	5	BRAKE SUPPORT PLATE .....	20
PARKING BRAKE .....	5	REAR PARKING BRAKE CABLES .....	21
BRAKE HOSES AND LINES .....	6	PARKING BRAKE LEVER .....	21
<b>DIAGNOSIS AND TESTING</b>		<b>DISASSEMBLY AND ASSEMBLY</b>	
BASE BRAKE SYSTEM .....	6	MASTER CYLINDER RESERVOIR .....	22
STOP LAMP SWITCH .....	8	DISC BRAKE CALIPER .....	23
RED BRAKE WARNING LAMP .....	8	WHEEL CYLINDER .....	25
MASTER CYLINDER/POWER BOOSTER .....	9	<b>CLEANING AND INSPECTION</b>	
COMBINATION VALVE .....	9	CALIPER .....	25
DISC BRAKE ROTOR .....	10	REAR DRUM BRAKE .....	26
BRAKE DRUM .....	10	WHEEL CYLINDER .....	26
BRAKE LINE AND HOSES .....	11	<b>ADJUSTMENTS</b>	
BRAKE FLUID CONTAMINATION .....	11	STOP LAMP SWITCH .....	26
<b>SERVICE PROCEDURES</b>		REAR DRUM BRAKE .....	27
BRAKE FLUID LEVEL .....	11	PARKING BRAKE CABLE TENSIONER .....	28
MASTER CYLINDER BLEEDING .....	11	<b>SPECIFICATIONS</b>	
BASE BRAKE BLEEDING .....	12	BRAKE FLUID .....	28
DISC ROTOR MACHINING .....	12	BRAKE COMPONENTS .....	29
BRAKE DRUM MACHINING .....	12	TORQUE CHART .....	29
BRAKE TUBE FLARING .....	13	<b>SPECIAL TOOLS</b>	
		BASE BRAKES .....	29

## GENERAL INFORMATION

### BRAKE SYSTEM

Power assist front disc and rear drum brakes are standard equipment. Disc brake components consist of single piston calipers and ventilated rotors. Rear drum brakes are dual shoe units with cast brake drums.

The parking brake mechanism is lever and cable operated. The cables are attached to levers on the rear drum brake secondary shoes. The parking brakes are operated by a hand lever.

A dual diaphragm vacuum power brake booster is used for all applications. All models have an aluminum master cylinder with plastic reservoir.

All models are equipped with a combination valve. The valve contains a pressure differential valve and switch and a fixed rate rear proportioning valve.

Factory brake lining on all models consists of an organic base material combined with metallic particles. The original equipment linings do not contain asbestos.

### SERVICE WARNINGS & CAUTIONS

**WARNING: DUST AND DIRT ACCUMULATING ON BRAKE PARTS DURING NORMAL USE MAY CONTAIN ASBESTOS FIBERS FROM AFTERMARKET LININGS. BREATHING EXCESSIVE CONCENTRATIONS OF ASBESTOS FIBERS CAN CAUSE SERIOUS BODILY HARM. EXERCISE CARE WHEN SERVICING BRAKE PARTS. DO NOT CLEAN BRAKE PARTS WITH COMPRESSED AIR OR BY DRY BRUSHING. USE A VACUUM CLEANER SPECIFICALLY DESIGNED FOR THE REMOVAL OF ASBESTOS FIBERS FROM BRAKE COMPONENTS. IF A SUITABLE VACUUM CLEANER IS NOT AVAILABLE, CLEANING SHOULD BE DONE WITH A WATER DAMPENED CLOTH. DO NOT SAND, OR GRIND BRAKE LINING UNLESS EQUIPMENT USED IS DESIGNED TO CONTAIN THE DUST RESIDUE. DISPOSE OF ALL RESIDUE CONTAINING ASBESTOS FIBERS IN SEALED BAGS OR CONTAINERS TO MINIMIZE EXPOSURE TO YOURSELF AND OTHERS. FOLLOW PRACTICES PRESCRIBED BY THE OCCUPATIONAL SAFETY AND HEALTH ADMINISTRATION AND THE ENVIRONMENTAL PROTECTION AGENCY FOR THE HANDLING, PROCESSING, AND DISPOSITION OF DUST OR DEBRIS THAT MAY CONTAIN ASBESTOS FIBERS.**

**CAUTION:** Never use gasoline, kerosene, alcohol, motor oil, transmission fluid, or any fluid containing mineral oil to clean the system components. These fluids damage rubber cups and seals. Use only fresh brake fluid or Mopar brake cleaner to clean or

flush brake system components. These are the only cleaning materials recommended. If system contamination is suspected, check the fluid for dirt, discoloration, or separation into distinct layers. Also check the reservoir cap seal for distortion. Drain and flush the system with new brake fluid if contamination is suspected.

**CAUTION:** Use Mopar brake fluid, or an equivalent quality fluid meeting SAE/DOT standards J1703 and DOT 3. Brake fluid must be clean and free of contaminants. Use fresh fluid from sealed containers only to ensure proper antilock component operation.

**CAUTION:** Use Mopar multi-mileage or high temperature grease to lubricate caliper slide surfaces, drum brake pivot pins, and shoe contact points on the backing plates. Use multi-mileage grease or GE 661 or Dow 111 silicone grease on caliper slide pins to ensure proper operation.

## DESCRIPTION AND OPERATION

### BRAKE PEDAL

A suspended-type brake pedal is used, the pedal pivots on a shaft mounted in the pedal support bracket. The bracket is attached to the dash panel and steering support bracket. The unit is serviced as an assembly, except for the pedal pad.

### STOP LAMP SWITCH

The plunger type stop lamp switch is mounted on a bracket attached to the brake pedal support. The switch can be adjusted when necessary.

### RED BRAKE WARNING LAMP

A red warning lamp is used for the service brake portion of the hydraulic system. The lamp is located in the instrument cluster. The red warning light alerts the driver if a pressure differential exists between the front and rear hydraulic systems or the parking brakes are applied.

The lamp is turned on momentarily when the ignition switch is turned to the on position. This is a self test to verify the lamp is operational.

### POWER BRAKE BOOSTER

The booster assembly consists of a housing divided into separate chambers by two internal diaphragms. The outer edge of each diaphragm is attached to the booster housing. The diaphragms are connected to the booster primary push rod.

DESCRIPTION AND OPERATION (Continued)

Two push rods are used in the booster. The primary push rod connects the booster to the brake pedal. The secondary push rod connects the booster to the master cylinder to stroke the cylinder pistons.

The atmospheric inlet valve is opened and closed by the primary push rod. Booster vacuum supply is through a hose attached to an intake manifold fitting at one end and to the booster check valve at the other. The vacuum check valve in the booster housing is a one-way device that prevents vacuum leak back.

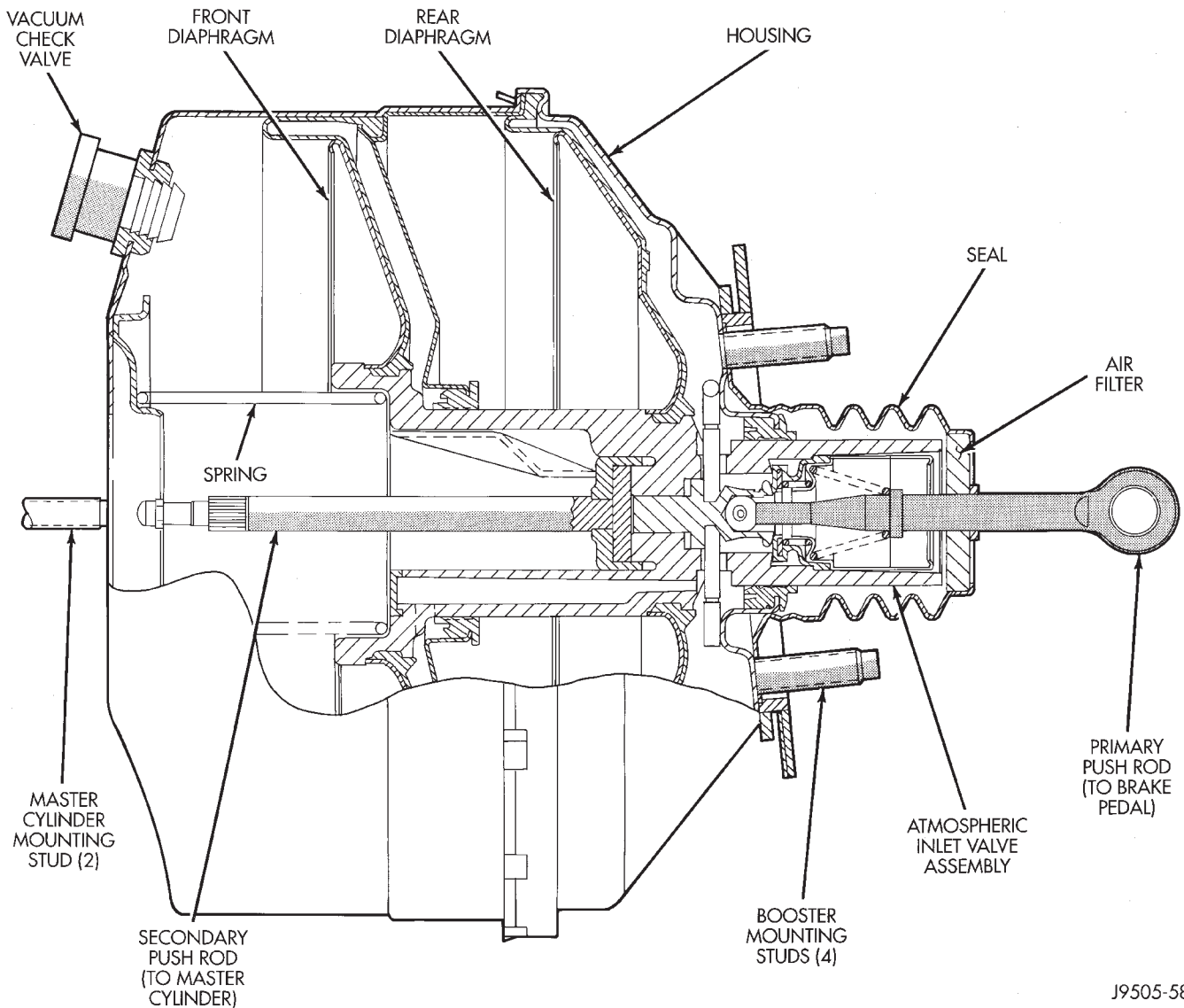
Power assist is generated by utilizing the pressure differential between normal atmospheric pressure and a vacuum. The vacuum needed for booster operation is taken directly from the engine intake manifold. The entry point for atmospheric pressure is through a filter and inlet valve at the rear of the housing (Fig. 1).

The chamber areas forward of the booster diaphragms are exposed to vacuum from the intake manifold. The chamber areas to the rear of the diaphragms, are exposed to normal atmospheric pressure of 101.3 kilopascals (14.7 pounds/square in.).

Brake pedal application causes the primary push rod to open the atmospheric inlet valve. This exposes the area behind the diaphragms to atmospheric pressure. The resulting pressure differential provides the extra apply force for power assist.

**MASTER CYLINDER**

The master cylinder has a removable nylon reservoir. The cylinder body is made of aluminum and contains a primary and secondary piston assembly. The cylinder body including the piston assemblies are not serviceable. If diagnosis indicates an internal problem with the cylinder body, it must be replaced



J9505-58

**Fig. 1 Power Brake Booster—Typical**

## DESCRIPTION AND OPERATION (Continued)

as an assembly. The reservoir and grommets are the only replaceable parts on the master cylinder.

**COMBINATION VALVE**

The combination valve contains a pressure differential valve and switch and a rear brake proportioning valve. The valve is not repairable and must be replaced as an assembly if diagnosis indicates this is necessary.

**PRESSURE DIFFERENTIAL VALVE**

The pressure differential switch is connected to the brake warning light. The switch is actuated by movement of the switch valve. The switch monitors fluid pressure in the separate front/rear brake hydraulic circuits.

A decrease or loss of fluid pressure in either hydraulic circuit will cause the switch valve to shuttle to the low pressure side. Movement of the valve pushes the switch plunger upward. This action closes the switch internal contacts completing the electrical circuit to the red warning light. The switch valve will remain in an actuated position until repairs to the brake system are made.

**PROPORTIONING VALVE**

The proportioning valve is used to balance front-rear brake action at high decelerations. The valve allows normal fluid flow during moderate braking. The valve only controls fluid flow during high decelerations brake stops.

**FRONT DISC BRAKES**

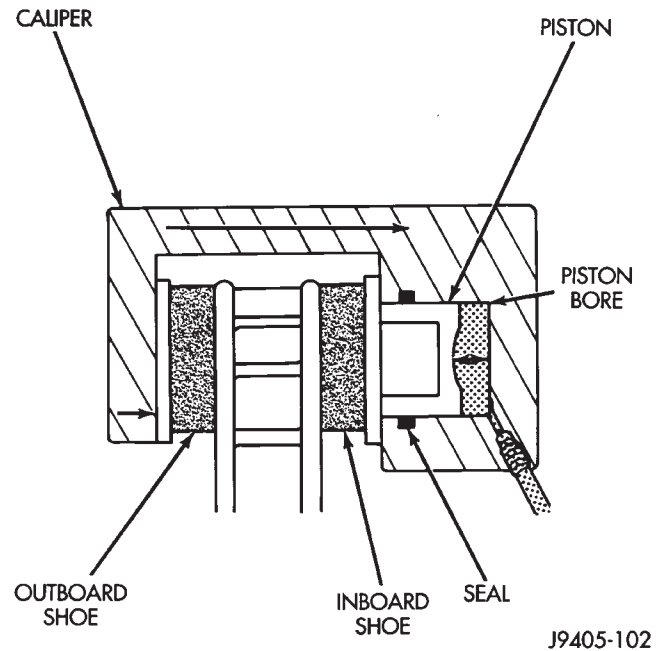
The calipers are a single piston type. The calipers are free to slide laterally, this allows continuous compensation for lining wear.

When the brakes are applied fluid pressure is exerted against the caliper piston. The fluid pressure is exerted equally and in all directions. This means pressure exerted against the caliper piston and within the caliper bore will be equal (Fig. 2).

Fluid pressure applied to the piston is transmitted directly to the inboard brake shoe. This forces the shoe lining against the inner surface of the disc brake rotor. At the same time, fluid pressure within the piston bore forces the caliper to slide inward on the mounting bolts. This action brings the outboard brake shoe lining into contact with the outer surface of the disc brake rotor.

In summary, fluid pressure acting simultaneously on both piston and caliper, produces a strong clamping action. When sufficient force is applied, friction will stop the rotors from turning and bring the vehicle to a stop.

Application and release of the brake pedal generates only a very slight movement of the caliper and



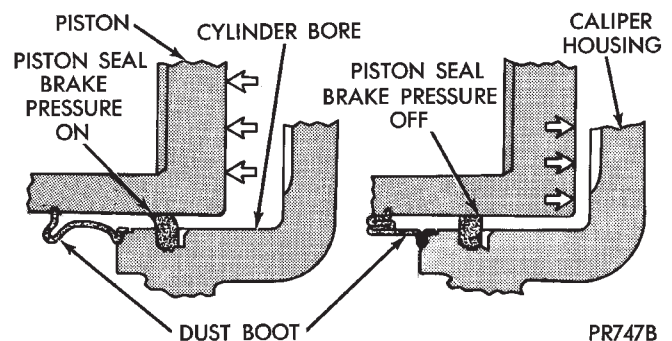
**Fig. 2 Brake Caliper Operation**

piston. Upon release of the pedal, the caliper and piston return to a rest position. The brake shoes do not retract an appreciable distance from the rotor. In fact, clearance is usually at, or close to zero. The reasons for this are to keep road debris from getting between the rotor and lining and in wiping the rotor surface clear each revolution.

The caliper piston seal controls the amount of piston extension needed to compensate for normal lining wear.

During brake application, the seal is deflected outward by fluid pressure and piston movement (Fig. 3). When the brakes (and fluid pressure) are released, the seal relaxes and retracts the piston.

The amount of piston retraction is determined by the amount of seal deflection. Generally the amount is just enough to maintain contact between the piston and inboard brake shoe.



**Fig. 3 Lining Wear Compensation By Piston Seal**

## DESCRIPTION AND OPERATION (Continued)

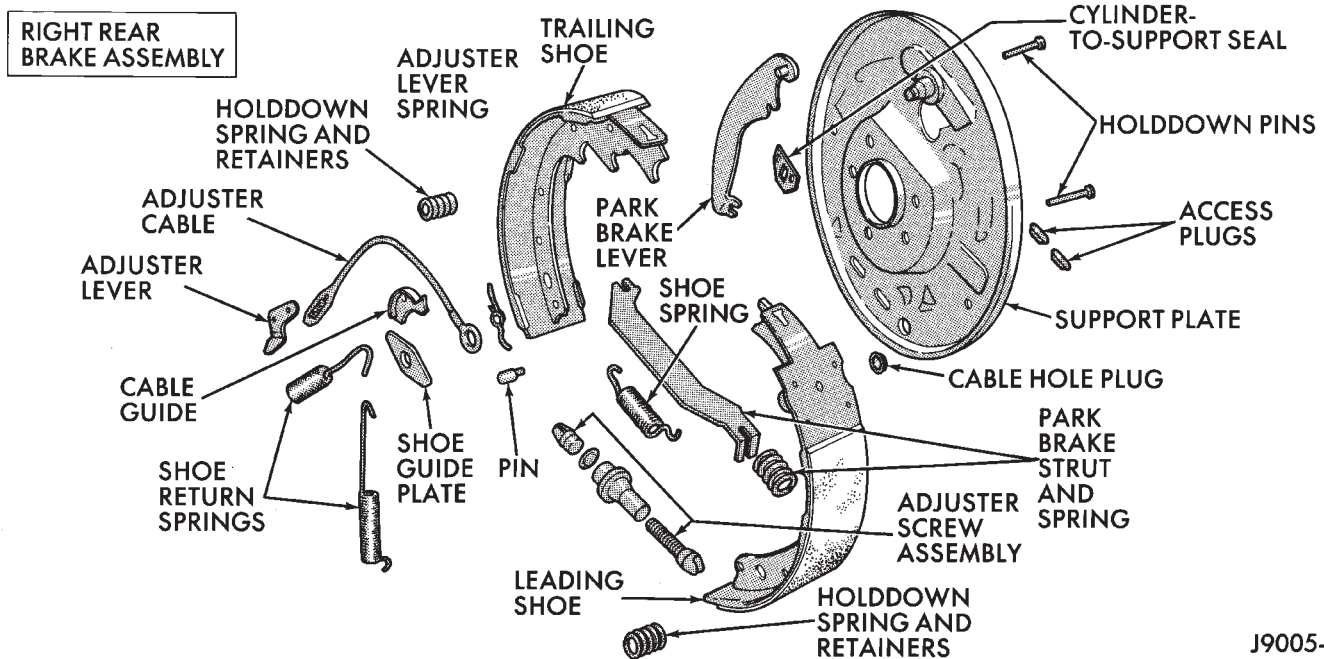


Fig. 4 Brake Components

**REAR DRUM BRAKE**

The brake systems use a leading shoe (primary) and trailing shoe (secondary) (Fig. 4). When the brake pedal is depressed hydraulic pressure pushes the rear brake wheel cylinder pistons outward. The wheel cylinder push rods then push the brake shoes outward against the brake drum. When the brake pedal is released return springs attached to the brake shoes pull the shoes back to their original position.

**PARKING BRAKE**

Parking brake adjustment is controlled by a cable tensioner mechanism. The cable tensioner, once adjusted at the factory, should not need further adjustment under normal circumstances. Adjustment may be required if a new tensioner, or cables are installed, or disconnected.

**PARKING BRAKE OPERATION**

A hand operated lever in the passenger compartment is the main application device. The front cable is connected between the hand lever and the tensioner. The tensioner rod is attached to the equalizer which is the connecting point for the rear cables (Fig. 5).

The rear cables are connected to the actuating lever on each secondary brake shoe. The levers are attached to the brake shoes by a pin either pressed into, or welded to the lever. A clip is used to secure the pin in the brake shoe. The pin allows each lever to pivot independently of the brake shoe.

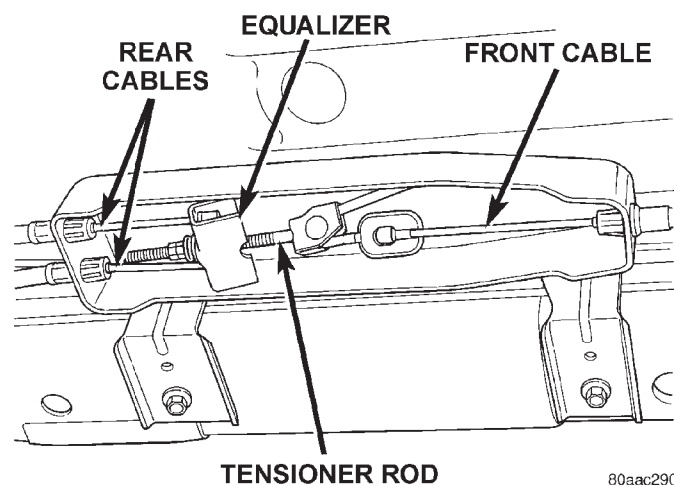


Fig. 5 Parking Brake Components

To apply the parking brakes, the hand lever is pulled upward. This pulls the rear brake shoe actuating levers forward, by means tensioner and cables. As the actuating lever is pulled forward, the parking brake strut (which is connected to both shoes), exerts a linear force against the primary brake shoe. This action presses the primary shoe into contact with the drum. Once the primary shoe contacts the drum, force is exerted through the strut. This force is transferred through the strut to the secondary brake shoe causing it to pivot into the drum as well.

A gear type ratcheting mechanism is used to hold the lever in an applied position. Parking brake release is accomplished by the hand lever release button.

## DESCRIPTION AND OPERATION (Continued)

A parking brake switch is mounted on the parking brake lever and is actuated by movement of the lever. The switch, which is in circuit with the red warning light in the dash, will illuminate the warning light whenever the parking brakes are applied.

## BRAKE HOSES AND LINES

Flexible rubber hose is used at both front brakes and at the rear axle junction block. Double walled steel tubing is used to connect the master cylinder to the major hydraulic braking components and then to the flexible rubber hoses.

## DIAGNOSIS AND TESTING

## BASE BRAKE SYSTEM

Base brake components consist of the brake shoes, calipers, wheel cylinders, brake drums, rotors, brake lines, master cylinder, booster, and parking brake components.

Brake diagnosis involves determining if the problem is related to a mechanical, hydraulic, or vacuum operated component.

The first diagnosis step is the preliminary check.

## PRELIMINARY BRAKE CHECK

(1) Check condition of tires and wheels. Damaged wheels and worn, damaged, or underinflated tires can cause pull, shudder, vibration, and a condition similar to grab.

(2) If complaint was based on noise when braking, check suspension components. Jounce front and rear of vehicle and listen for noise that might be caused by loose, worn or damaged suspension or steering components.

(3) Inspect brake fluid level and condition. Note that the brake reservoir fluid level will decrease in proportion to normal lining wear. **Also note that brake fluid tends to darken over time. This is normal and should not be mistaken for contamination.**

(a) If fluid level is abnormally low, look for evidence of leaks at calipers, wheel cylinders, brake lines, and master cylinder.

(b) If fluid appears contaminated, drain out a sample to examine. System will have to be flushed if fluid is separated into layers, or contains a substance other than brake fluid. The system seals and cups will also have to be replaced after flushing. Use clean brake fluid to flush the system.

(4) Check parking brake operation. Verify free movement and full release of cables and pedal. Also note if vehicle was being operated with parking brake partially applied.

(5) Check brake pedal operation. Verify that pedal does not bind and has adequate free play. If pedal

lacks free play, check pedal and power booster for being loose or for bind condition. Do not road test until condition is corrected.

(6) Check booster vacuum check valve and hose.

(7) If components checked appear OK, road test the vehicle.

## ROAD TESTING

(1) If complaint involved low brake pedal, pump pedal and note if it comes back up to normal height.

(2) Check brake pedal response with transmission in Neutral and engine running. Pedal should remain firm under constant foot pressure.

(3) During road test, make normal and firm brake stops in 25-40 mph range. Note faulty brake operation such as low pedal, hard pedal, fade, pedal pulsation, pull, grab, drag, noise, etc.

(4) Attempt to stop the vehicle with the parking brake only and note grab, drag, noise, etc.

## PEDAL FALLS AWAY

A brake pedal that falls away under steady foot pressure is generally the result of a system leak. The leak point could be at a brake line, fitting, hose, or caliper/wheel cylinder. If leakage is severe, fluid will be evident at or around the leaking component.

Internal leakage (seal by-pass) in the master cylinder caused by worn or damaged piston cups, may also be the problem cause.

An internal leak in the ABS or RWAL system may also be the problem with no physically evident.

## LOW PEDAL

If a low pedal is experienced, pump the pedal several times. If the pedal comes back up worn linings, rotors, drums, or rear brakes out of adjustment are the most likely causes. The proper course of action is to inspect and replace all worn component and make the proper adjustments.

## SPONGY PEDAL

A spongy pedal is most often caused by air in the system. However, thin brake drums or substandard brake lines and hoses can also cause a spongy pedal. The proper course of action is to bleed the system, and replace thin drums and substandard quality brake hoses if suspected.

## HARD PEDAL OR HIGH PEDAL EFFORT

A hard pedal or high pedal effort may be due to lining that is water soaked, contaminated, glazed, or badly worn. The power booster or check valve could also be faulty.

## PEDAL PULSATION

Pedal pulsation is caused by components that are loose, or beyond tolerance limits.

## DIAGNOSIS AND TESTING (Continued)

The primary cause of pulsation are disc brake rotors with excessive lateral runout or thickness variation, or out of round brake drums. Other causes are loose wheel bearings or calipers and worn, damaged tires.

**NOTE: Some pedal pulsation may be felt during ABS activation.**

### BRAKE DRAG

Brake drag occurs when the lining is in constant contact with the rotor or drum. Drag can occur at one wheel, all wheels, fronts only, or rears only.

Drag is a product of incomplete brake shoe release. Drag can be minor or severe enough to overheat the linings, rotors and drums.

Minor drag will usually cause slight surface charring of the lining. It can also generate hard spots in rotors and drums from the overheat-cool down process. In most cases, the rotors, drums, wheels and tires are quite warm to the touch after the vehicle is stopped.

Severe drag can char the brake lining all the way through. It can also distort and score rotors and drums to the point of replacement. The wheels, tires and brake components will be extremely hot. In severe cases, the lining may generate smoke as it chars from overheating.

Common causes of brake drag are:

- Seized or improperly adjusted parking brake cables.
- Loose/worn wheel bearing.
- Seized caliper or wheel cylinder piston.
- Caliper binding on corroded bushings or rusted slide surfaces.
- Loose caliper mounting.
- Drum brake shoes binding on worn/damaged support plates.
- Mis-assembled components.

If brake drag occurs at all wheels, the problem may be related to a blocked master cylinder return port, or faulty power booster (binds-does not release).

### BRAKE FADE

Brake fade is usually a product of overheating caused by brake drag. However, brake overheating and resulting fade can also be caused by riding the brake pedal, making repeated high deceleration stops in a short time span, or constant braking on steep mountain roads. Refer to the Brake Drag information in this section for causes.

### BRAKE PULL

Front brake pull condition could result from:

- Contaminated lining in one caliper
- Seized caliper piston

- Binding caliper
- Loose caliper
- Rusty caliper slide surfaces
- Improper brake shoes
- Damaged rotor

A worn, damaged wheel bearing or suspension component are further causes of pull. A damaged front tire (bruised, ply separation) can also cause pull.

A common and frequently misdiagnosed pull condition is where direction of pull changes after a few stops. The cause is a combination of brake drag followed by fade at one of the brake units.

As the dragging brake overheats, efficiency is so reduced that fade occurs. Since the opposite brake unit is still functioning normally, its braking effect is magnified. This causes pull to switch direction in favor of the normally functioning brake unit.

An additional point when diagnosing a change in pull condition concerns brake cool down. Remember that pull will return to the original direction, if the dragging brake unit is allowed to cool down (and is not seriously damaged).

### REAR BRAKE GRAB OR PULL

Rear grab or pull is usually caused by improperly adjusted or seized parking brake cables, contaminated lining, bent or binding shoes and support plates, or improperly assembled components. This is particularly true when only one rear wheel is involved. However, when both rear wheels are affected, the master cylinder or proportioning valve could be at fault.

### BRAKES DO NOT HOLD AFTER DRIVING THROUGH DEEP WATER PUDDLES

This condition is generally caused by water soaked lining. If the lining is only wet, it can be dried by driving with the brakes very lightly applied for a mile or two. However, if the lining is both soaked and dirt contaminated, cleaning and/or replacement will be necessary.

### BRAKE LINING CONTAMINATION

Brake lining contamination is mostly a product of leaking calipers or wheel cylinders, worn seals, driving through deep water puddles, or lining that has become covered with grease and grit during repair. Contaminated lining should be replaced to avoid further brake problems.

### WHEEL AND TIRE PROBLEMS

Some conditions attributed to brake components may actually be caused by a wheel or tire problem.

A damaged wheel can cause shudder, vibration and pull. A worn or damaged tire can also cause pull.

## DIAGNOSIS AND TESTING (Continued)

Severely worn tires with very little tread left can produce a grab-like condition as the tire loses and recovers traction. Flat-spotted tires can cause vibration and generate shudder during brake operation. A tire with internal damage such as a severe bruise, cut, or ply separation can cause pull and vibration.

## BRAKE NOISES

Some brake noise is common with rear drum brakes and on some disc brakes during the first few stops after a vehicle has been parked overnight or stored. This is primarily due to the formation of trace corrosion (light rust) on metal surfaces. This light corrosion is typically cleared from the metal surfaces after a few brake applications causing the noise to subside.

## BRAKE SQUEAK/SQUEAL

Brake squeak or squeal may be due to linings that are wet or contaminated with brake fluid, grease, or oil. Glazed linings and rotors with hard spots can also contribute to squeak. Dirt and foreign material embedded in the brake lining will also cause squeak/squeal.

A very loud squeak or squeal is frequently a sign of severely worn brake lining. If the lining has worn through to the brake shoes in spots, metal-to-metal contact occurs. If the condition is allowed to continue, rotors and drums can become so scored that replacement is necessary.

## BRAKE CHATTER

Brake chatter is usually caused by loose or worn components, or glazed/burnt lining. Rotors with hard spots can also contribute to chatter. Additional causes of chatter are out-of-tolerance rotors, brake lining not securely attached to the shoes, loose wheel bearings and contaminated brake lining.

## THUMP/CLUNK NOISE

Thumping or clunk noises during braking are frequently **not** caused by brake components. In many cases, such noises are caused by loose or damaged steering, suspension, or engine components. However, calipers that bind on the slide surfaces can generate a thump or clunk noise. In addition, worn out, improperly adjusted, or improperly assembled rear brake shoes can also produce a thump noise.

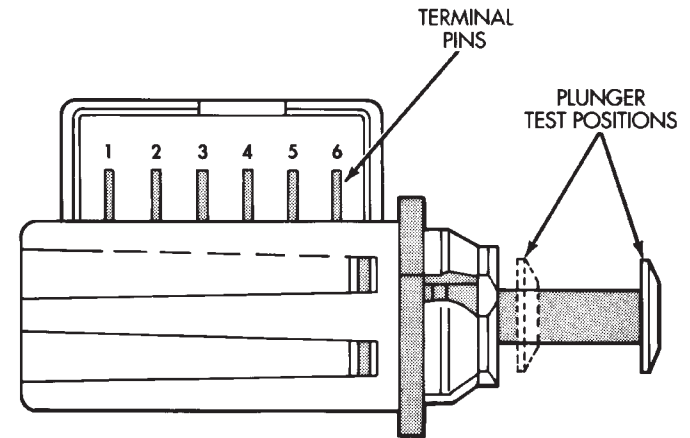
## STOP LAMP SWITCH

Stop lamp switch operation can be tested with an ohmmeter. The ohmmeter is used to check continuity between the pin terminals at different plunger positions (Fig. 6).

**NOTE:** The switch wire harness must be disconnected before testing switch continuity.

## SWITCH CIRCUIT IDENTIFICATION

- Terminals 1 and 2 are for brake sensor circuit.
- Terminals 5 and 6 are for the stop lamp circuit.
- Terminals 3 and 4 are for the speed control circuit.



J9405-88

**Fig. 6 Stop Lamp Switch Terminal Identification**

## SWITCH CONTINUITY TEST

(1) Check continuity between terminal pins 5 and 6 as follows:

(a) Pull plunger all the way out to fully extended position.

(b) Attach test leads to pins 5 and 6 and note ohmmeter reading.

(c) If continuity exists, proceed to next test. Replace switch if meter indicates lack of continuity (shorted or open).

(2) Check continuity between terminal pins 1 and 2 and pins 3 and 4 as follows:

(a) Push switch plunger inward to fully retracted position.

(b) Attach test leads to pins 1 and 2 and note ohmmeter reading.

(c) If continuity exists, switch is OK. Replace switch if meter indicates lack of continuity (switch is open).

## RED BRAKE WARNING LAMP

The red brake warning lamp will illuminate under the following conditions:

- Self test at start-up.
- Parking brakes are applied.
- Leak in front/rear brake hydraulic circuit.

If the red light remains on after start-up, first verify that the parking brakes are fully released. Then check pedal action and fluid level. If the lamp on and the brake pedal is low this indicates the pressure differential switch and valve have been actuated due to a leak in the hydraulic system.

On models with ABS brakes, the amber warning lamp only illuminates during the self test and when



DIAGNOSIS AND TESTING (Continued)

an ABS malfunction has occurred. The ABS lamp operates independently of the red warning lamp.  
 For additional information refer to Group 8W.

**MASTER CYLINDER/POWER BOOSTER**

- (1) Start engine and check booster vacuum hose connections. A hissing noise indicates vacuum leak. Correct any vacuum leak before proceeding.
- (2) Stop engine and shift transmission into Neutral.
- (3) Pump brake pedal until all vacuum reserve in booster is depleted.
- (4) Press and hold brake pedal under light foot pressure. The pedal should hold firm, if the pedal falls away master cylinder is faulty (internal leakage).
- (5) Start engine and note pedal action it should fall away slightly under light foot pressure then hold firm. If no pedal action is discernible, power booster, vacuum supply, or vacuum check valve is faulty. Proceed to the POWER BOOSTER VACUUM TEST.

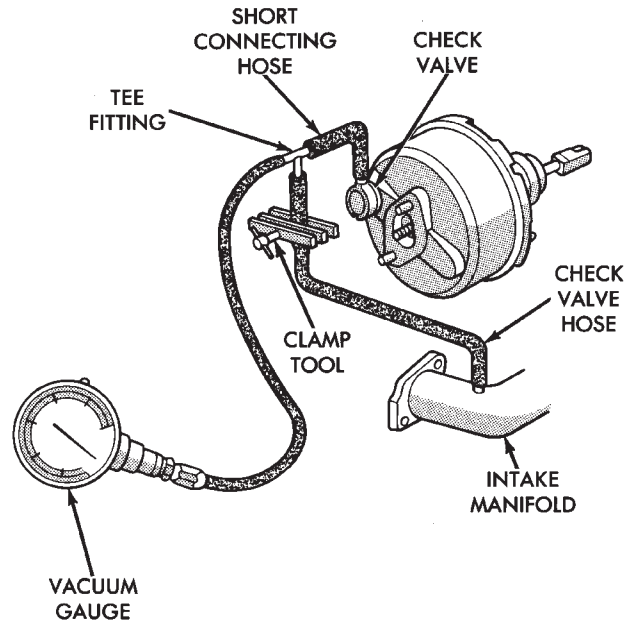
- (6) If the POWER BOOSTER VACUUM TEST passes, rebuild booster vacuum reserve as follows: Release brake pedal. Increase engine speed to 1500 rpm, close the throttle and immediately stop turn off ignition to stop engine.
- (7) Wait a minimum of 90 seconds and try brake action again. Booster should provide two or more vacuum assisted pedal applications. If vacuum assist is not provided, booster is faulty.

**POWER BOOSTER VACUUM TEST**

- (1) Connect vacuum gauge to booster check valve with short length of hose and T-fitting (Fig. 7).
- (2) Start and run engine at curb idle speed for one minute.
- (3) Observe the vacuum supply. If vacuum supply is not adequate, repair vacuum supply.
- (4) Clamp hose shut between vacuum source and check valve.
- (5) Stop engine and observe vacuum gauge.
- (6) If vacuum drops more than one inch HG (33 millibars) within 15 seconds, booster diaphragm or check valve is faulty.

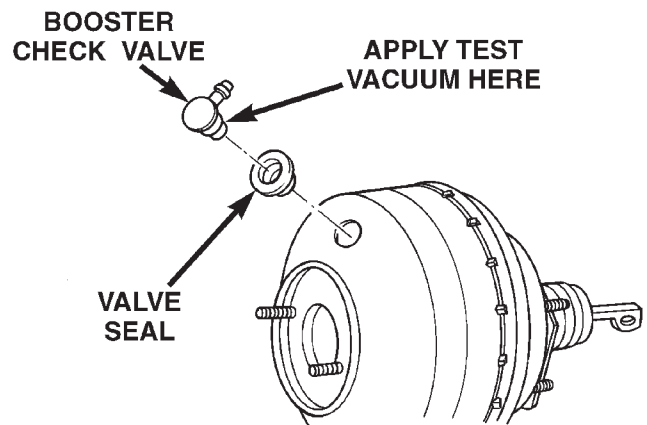
**POWER BOOSTER CHECK VALVE TEST**

- (1) Disconnect vacuum hose from check valve.
- (2) Remove check valve and valve seal from booster.
- (3) Use a hand operated vacuum pump for test.
- (4) Apply 15-20 inches vacuum at large end of check valve (Fig. 8).
- (5) Vacuum should hold steady. If gauge on pump indicates vacuum loss, check valve is faulty and should be replaced.



J9005-81

**Fig. 7 Typical Booster Vacuum Test Connections**



8031e866

**Fig. 8 Vacuum Check Valve And Seal**

**COMBINATION VALVE**

**PRESSURE DIFFERENTIAL SWITCH**

- (1) Have helper sit in drivers seat to apply brake pedal and observe red brake warning light.
- (2) Raise vehicle on hoist.
- (3) Connect bleed hose to a rear wheel cylinder and immerse hose end in container partially filled with brake fluid.
- (4) Have helper press and hold brake pedal to floor and observe warning light.
  - (a) If warning light illuminates, switch is operating correctly.
  - (b) If light fails to illuminate, check circuit fuse, bulb, and wiring. The parking brake switch can be used to aid in identifying whether or not the brake

## DIAGNOSIS AND TESTING (Continued)

light bulb and fuse is functional. Repair or replace parts as necessary and test differential pressure switch operation again.

(5) If warning light still does not illuminate, switch is faulty. Replace combination valve assembly, bleed brake system and verify proper switch and valve operation.

**REAR PROPORTIONING VALVE**

The valve controls fluid flow. If fluid enters the valve and does not exit the valve the combination valve must be replaced.

**DISC BRAKE ROTOR**

The rotor braking surfaces should not be refinished unless necessary.

Light surface rust and scale can be removed with a lathe equipped with dual sanding discs. The rotor surfaces can be restored by machining in a disc brake lathe if surface scoring and wear are light.

Replace the rotor under the following conditions:

- severely scored
- tapered
- hard spots
- cracked
- below minimum thickness

**ROTOR MINIMUM THICKNESS**

Measure rotor thickness at the center of the brake shoe contact surface. Replace the rotor if worn below minimum thickness, or if machining would reduce thickness below the allowable minimum.

Rotor minimum thickness is usually specified on the rotor hub. The specification is either stamped or cast into the hub surface.

**ROTOR RUNOUT**

Check rotor lateral runout with dial indicator C-3339 (Fig. 9). Excessive lateral runout will cause brake pedal pulsation and rapid, uneven wear of the brake shoes. Position the dial indicator plunger approximately 25.4 mm (1 in.) inward from the rotor edge. Maximum allowable rotor runout is 0.102 mm (0.004 in.).

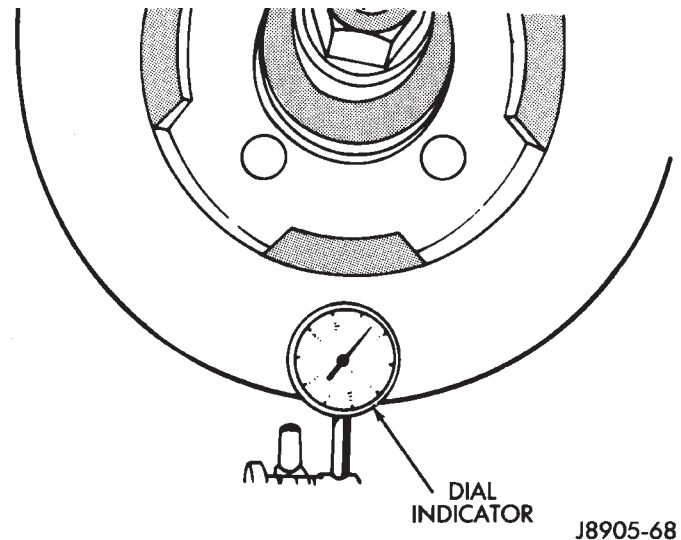
**ROTOR THICKNESS VARIATION**

Variations in rotor thickness will cause pedal pulsation, noise and shudder.

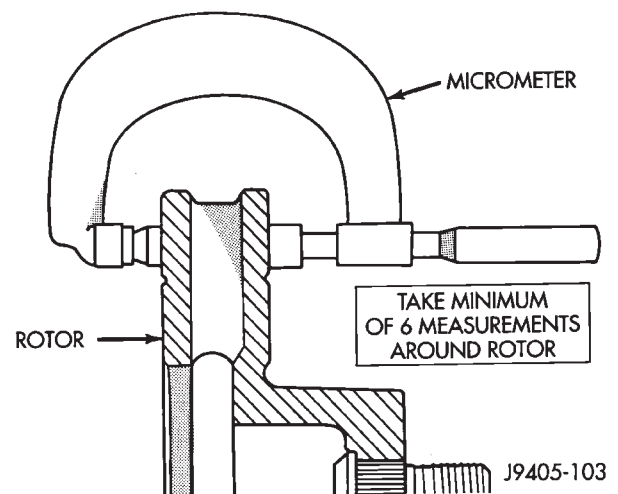
Measure rotor thickness at 6 to 12 points around the rotor face (Fig. 10).

Position the micrometer approximately 25.4 mm (1 in.) from the rotor outer circumference for each measurement.

Thickness should not vary by more than 0.013 mm (0.0005 in.) from point-to-point on the rotor. Machine or replace the rotor if necessary.



**Fig. 9 Checking Rotor Runout And Thickness Variation**



**Fig. 10 Measuring Rotor Thickness**

**BRAKE DRUM**

The maximum allowable diameter of the drum braking surface is indicated on the drum outer edge. Generally, a drum can be machined to a maximum of 1.52 mm (0.060 in.) oversize. Always replace the drum if machining would cause drum diameter to exceed the size limit indicated on the drum.

**BRAKE DRUM RUNOUT**

Measure drum diameter and runout with an accurate gauge. The most accurate method of measurement involves mounting the drum in a brake lathe and checking variation and runout with a dial indicator.

Variations in drum diameter should not exceed 0.076 mm (0.003 in.). Drum runout should not exceed 0.20 mm (0.008 in.) out of round. Machine the drum

**DIAGNOSIS AND TESTING (Continued)**

if runout or variation exceed these values. Replace the drum if machining causes the drum to exceed the maximum allowable diameter.

**BRAKE LINE AND HOSES**

Flexible rubber hose is used at both front brakes and at the rear axle junction block. Inspect the hoses whenever the brake system is serviced, at every engine oil change, or whenever the vehicle is in for service.

Inspect the hoses for surface cracking, scuffing, or worn spots. Replace any brake hose immediately if the fabric casing of the hose is exposed due to cracks or abrasions.

Also check brake hose installation. Faulty installation can result in kinked, twisted hoses, or contact with the wheels and tires or other chassis components. All of these conditions can lead to scuffing, cracking and eventual failure.

The steel brake lines should be inspected periodically for evidence of corrosion, twists, kinks, leaks, or other damage. Heavily corroded lines will eventually rust through causing leaks. In any case, corroded or damaged brake lines should be replaced.

Factory replacement brake lines and hoses are recommended to ensure quality, correct length and superior fatigue life. Care should be taken to make sure that brake line and hose mating surfaces are clean and free from nicks and burrs. Also remember that right and left brake hoses are not interchangeable.

Use new copper seal washers at all caliper connections. Be sure brake line connections are properly made (not cross threaded) and tightened to recommended torque.

**BRAKE FLUID CONTAMINATION**

Indications of fluid contamination are swollen or deteriorated rubber parts.

Swollen rubber parts indicate the presence of petroleum in the brake fluid.

To test for contamination, put a small amount of drained brake fluid in clear glass jar. If fluid separates into layers, there is mineral oil or other fluid contamination of the brake fluid.

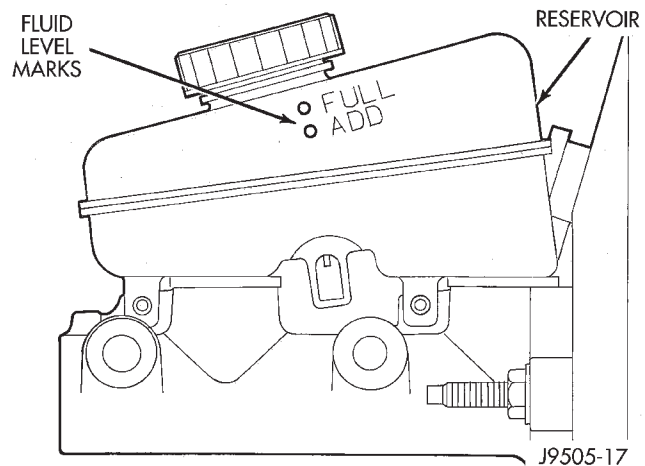
If brake fluid is contaminated, drain and thoroughly flush system. Replace master cylinder, proportioning valve, caliper seals, wheel cylinder seals, Antilock Brakes hydraulic unit and all hydraulic fluid hoses.

**SERVICE PROCEDURES****BRAKE FLUID LEVEL**

Always clean the master cylinder reservoir and cap before adding fluid. This will prevent dirt from fall-

ing in the reservoir and contaminating the brake fluid.

The reservoir has a ADD and a FULL mark on the side (Fig. 11) fill to the FULL mark.



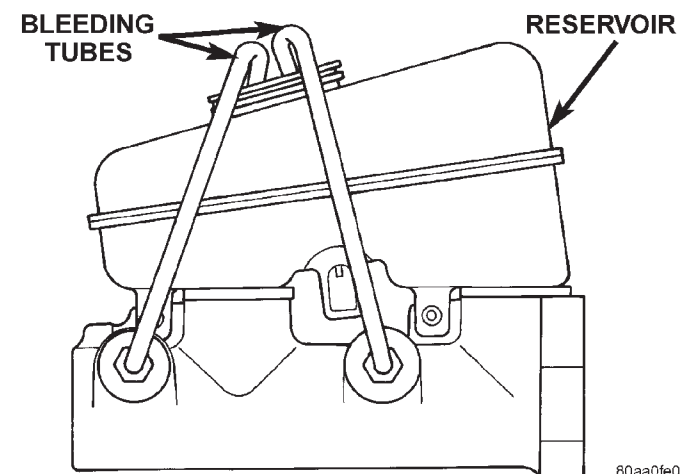
**Fig. 11 Master Cylinder Fluid Level**

**MASTER CYLINDER BLEEDING**

A new master cylinder should be bled before installation on the vehicle. Required bleeding tools include bleed tubes and a wood dowel to stroke the pistons. Bleed tubes can be fabricated from brake line.

**BLEEDING PROCEDURE**

- (1) Mount master cylinder in vise.
- (2) Attach bleed tubes to cylinder outlet ports. Then position each tube end into reservoir (Fig. 12).
- (3) Fill reservoir with fresh brake fluid.
- (4) Press cylinder pistons inward with wood dowel. Then release pistons and allow them to return under spring pressure. Continue bleeding operations until air bubbles are no longer visible in fluid.



**Fig. 12 Master Cylinder Bleeding—Typical**

## SERVICE PROCEDURES (Continued)

**BASE BRAKE BLEEDING**

Use Mopar brake fluid, or an equivalent quality fluid meeting SAE J1703-F and DOT 3 standards only. Use fresh, clean fluid from a sealed container at all times.

Do not pump the brake pedal at any time while bleeding. Air in the system will be compressed into small bubbles that are distributed throughout the hydraulic system. This will make additional bleeding operations necessary.

Do not allow the master cylinder to run out of fluid during bleed operations. An empty cylinder will allow additional air to be drawn into the system. Check the cylinder fluid level frequently and add fluid as needed.

Bleed only one brake component at a time in the following sequence:

- Master Cylinder
- Combination Valve
- Right Rear Wheel
- Left Rear Wheel
- Right Front Wheel
- Left Front Wheel

**MANUAL BLEEDING**

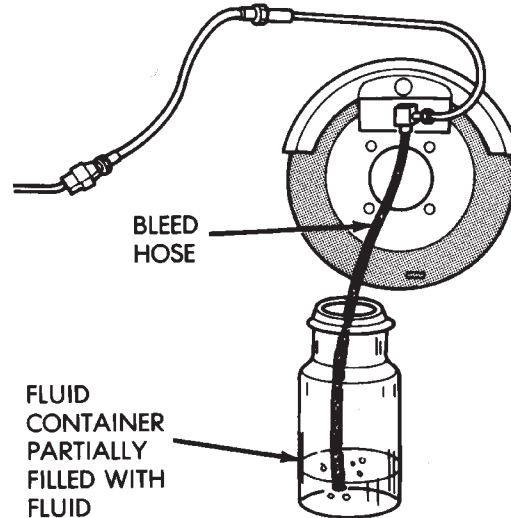
- (1) Remove reservoir filler caps and fill reservoir.
- (2) If calipers, or wheel cylinders were overhauled, open all caliper and wheel cylinder bleed screws. Then close each bleed screw as fluid starts to drip from it. Top off master cylinder reservoir once more before proceeding.
- (3) Attach one end of bleed hose to bleed screw and insert opposite end in glass container partially filled with brake fluid (Fig. 13). Be sure end of bleed hose is immersed in fluid.
- (4) Open up bleeder, then have a helper press down the brake pedal. Once the pedal is down close the bleeder. Repeat bleeding until fluid stream is clear and free of bubbles. Then move to the next wheel.

**PRESSURE BLEEDING**

Follow the manufacturers instructions carefully when using pressure equipment. Do not exceed the tank manufacturers pressure recommendations. Generally, a tank pressure of 15-20 psi is sufficient for bleeding.

Fill the bleeder tank with recommended fluid and purge air from the tank lines before bleeding.

Do not pressure bleed without a proper master cylinder adapter. The wrong adapter can lead to leakage, or drawing air back into the system. Use adapter provided with the equipment or Adapter 6921.



J8905-18

*Fig. 13 Bleed Hose Setup***DISC ROTOR MACHINING**

The disc brake rotor can be machined if scored or worn. The lathe must machine both sides of the rotor simultaneously with dual cutter heads. Equipment capable of machining only one side at a time may produce a tapered rotor. A hub mounted on-vehicle lathe is recommended. This type of lathe trues the rotor to the vehicles hub/bearing.

**CAUTION:** Brake rotors that do not meet minimum thickness specifications before or after machining must be replaced.

**BRAKE DRUM MACHINING**

The brake drums can be machined on a drum lathe when necessary. Initial machining cuts should be limited to 0.12 - 0.20 mm (0.005 - 0.008 in.) at a time as heavier feed rates can produce taper and surface variation. Final finish cuts of 0.025 to 0.038 mm (0.001 to 0.0015 in.) are recommended and will generally provide the best surface finish.

Be sure the drum is securely mounted in the lathe before machining operations. A damper strap should always be used around the drum to reduce vibration and avoid chatter marks.

The maximum allowable diameter of the drum braking surface is stamped or cast into the drum outer edge.

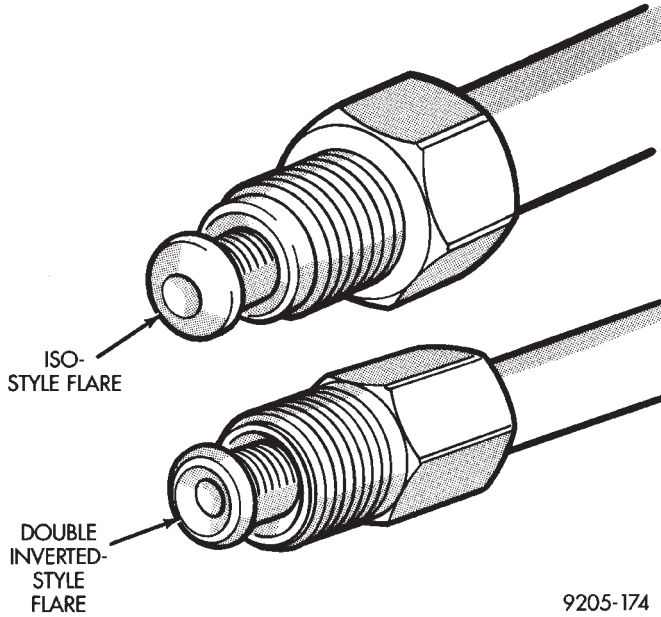
**CAUTION:** Replace the drum if machining will cause the drum to exceed the maximum allowable diameter.

SERVICE PROCEDURES (Continued)

**BRAKE TUBE FLARING**

A preformed metal brake tube is recommended and preferred for all repairs. However, double-wall steel tube can be used for emergency repair when factory replacement parts are not readily available.

Special bending tools are needed to avoid kinking or twisting of metal brake tubes. Special flaring tools are needed to make a double inverted flare or ISO flare (Fig. 14).



**Fig. 14 Inverted Flare And ISO Flare**

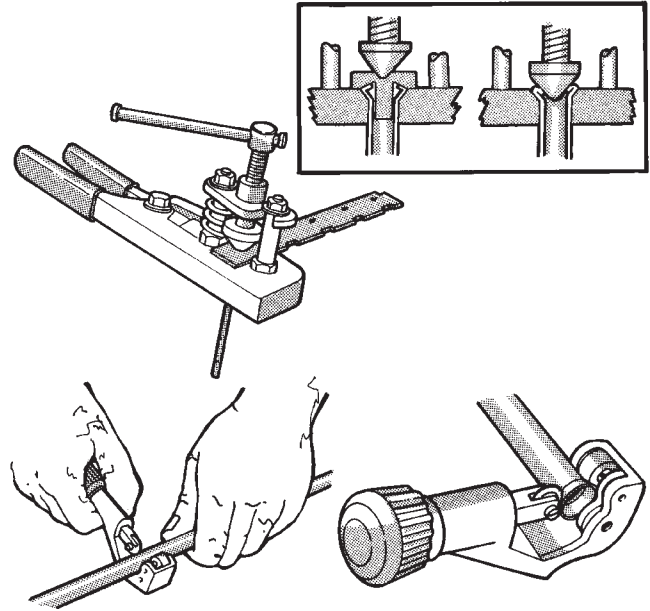
**DOUBLE INVERTED FLARING**

- (1) Cut off damaged tube with Tubing Cutter.
- (2) Ream cut edges of tubing to ensure proper flare.
- (3) Install replacement tube nut on the tube.
- (4) Insert tube in flaring tool.
- (5) Place gauge form over the end of the tube.
- (6) Push tubing through flaring tool jaws until tube contacts recessed notch in gauge that matches tube diameter.
- (7) Tighten the tool bar on the tube
- (8) Insert plug on gauge in the tube. Then swing compression disc over gauge and center tapered flaring screw in recess of compression disc (Fig. 15).
- (9) Tighten tool handle until plug gauge is squarely seated on jaws of flaring tool. This will start the inverted flare.
- (10) Remove the plug gauge and complete the inverted flare.

**ISO FLARING**

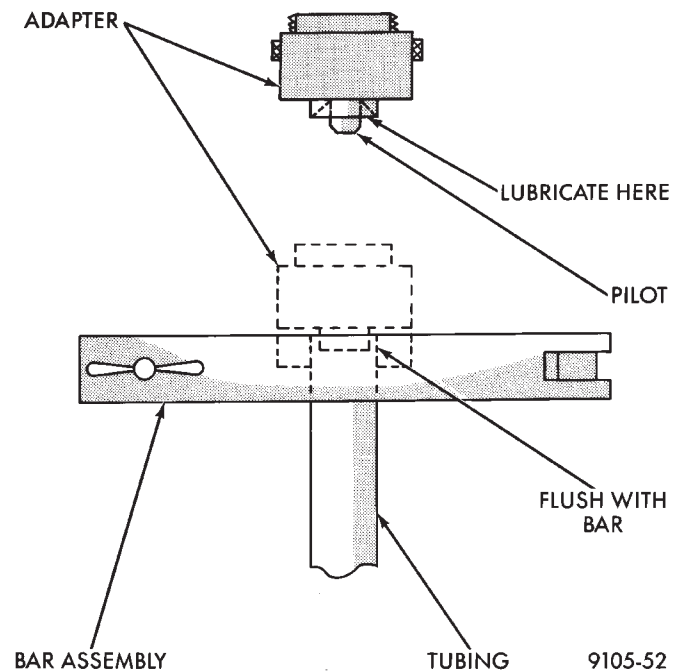
To make a ISO flare use Snap-On® Flaring Tool TFM-428 or equivalent.

- (1) Cut off damaged tube with Tubing Cutter.



**Fig. 15 Inverted Flare Tools**

- (2) Remove any burrs from the inside of the tube.
- (3) Install tube nut on the tube.
- (4) Position the tube in the flaring tool flush with the top of the tool bar (Fig. 16). Then tighten the tool bar on the tube.
- (5) Install the correct size adaptor on the flaring tool yoke screw.
- (6) Lubricate the adaptor.
- (7) Align the adaptor and yoke screw over the tube (Fig. 16).
- (8) Turn the yoke screw in until the adaptor is squarely seated on the tool bar.



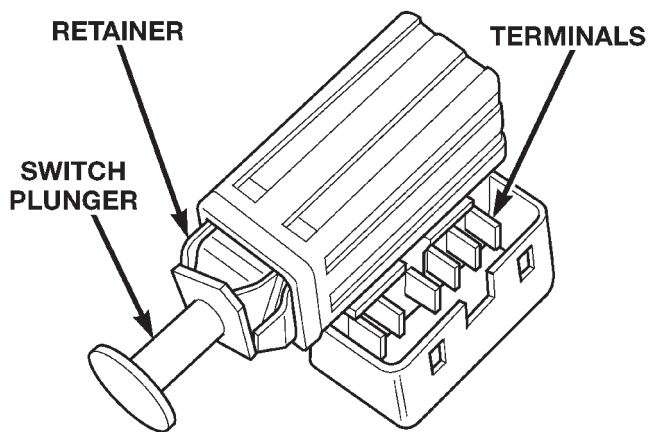
**Fig. 16 ISO Flaring**

## REMOVAL AND INSTALLATION

### STOP LAMP SWITCH

#### REMOVAL

- (1) Remove steering column cover and lower trim panel for switch access (if necessary).
- (2) Press brake pedal downward to fully applied position.
- (3) Rotate switch approximately 30° in counter-clockwise direction to unlock switch retainer. Then pull switch rearward and out of bracket.
- (4) Disconnect switch wire harness and remove switch from vehicle (Fig. 17).



80aafb2f

**Fig. 17 Stop Lamp Switch**

#### INSTALLATION

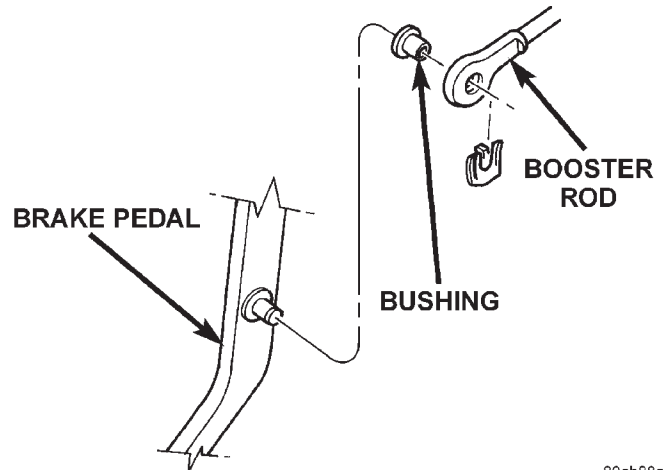
- (1) Pull switch plunger all the way out to fully extended position.
- (2) Connect harness wires to switch.
- (3) Press and hold brake pedal in applied position.
- (4) Install switch as follows: Align tab on switch with notch in switch bracket. Then insert switch in bracket and turn it clockwise about 30° to lock it in place.
- (5) Release brake pedal. Then pull pedal fully rearward. Pedal will set plunger to correct position as pedal pushes plunger into switch body. Switch will make ratcheting sound as it self adjusts.

### BRAKE PEDAL

#### REMOVAL

- (1) Remove knee blocker under the steering column.
- (2) Remove retainer clip securing booster push rod to pedal (Fig. 18).
- (3) Remove stop lamp switch.
- (4) Remove nuts securing the booster to the pedal support bracket and nuts to the column bracket.

- (5) Remove pedal and support bracket as an assembly from the vehicle.



80ab88a7

**Fig. 18 Booster Push Rod**

#### INSTALLATION

- (1) Install pedal and support bracket as an assembly into the vehicle.
- (2) Install nuts securing the booster to the pedal support bracket and nuts to the column bracket.
- (3) Tighten nuts to 39 N·m (29 ft. lbs.).
- (4) Lubricate the brake pedal pin and bushings with Mopar multi-mileage grease.
- (5) Install booster push rod on pedal pin and install new retainer clip.
- (6) Install knee blocker.

### COMBINATION VALVE

**NOTE: The combination valve is not repairable. The valve is serviced as an assembly only.**

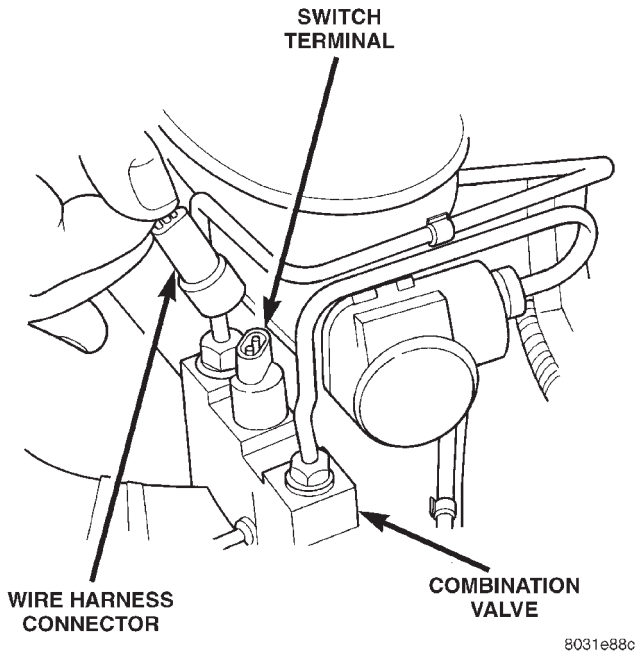
#### REMOVAL

- (1) Remove air cleaner cover and hose for access to valve.
- (2) Unsnap connector lock tabs and disconnect differential pressure switch wire at combination valve (Fig. 19). Do not pull switch wire to disconnect.
- (3) Disconnect brake lines at combination valve (Fig. 20).
- (4) Remove mounting nut and remove valve.

#### INSTALLATION

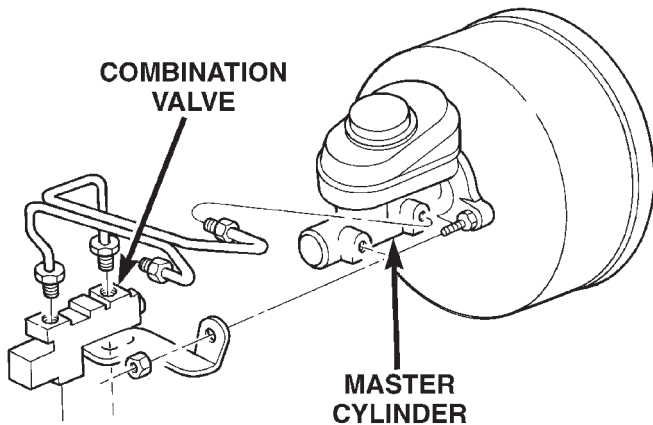
- (1) Install valve and tighten mounting nut to 17 N·m (155 in. lbs.).
- (2) Connect brake lines to replacement valve. Start line fittings by hand to avoid cross threading.
- (3) Tighten brake line fittings to 19 N·m (170 in. lbs.).
- (4) Connect wire to pressure differential switch.
- (5) Bleed base brakes.

REMOVAL AND INSTALLATION (Continued)



**Fig. 19 Differential Pressure Switch**

8031e88c



**Fig. 20 Combination Valve**

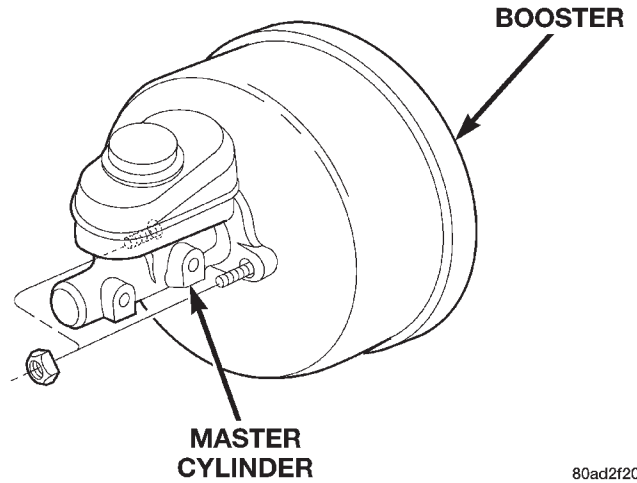
8031e88d

**MASTER CYLINDER**

**REMOVAL**

- (1) On RHD vehicles remove the coolant reserve/overflow tank. Refer to Group 7 Cooling System.
- (2) Remove brake lines at master cylinder and combination valve (Fig. 20).
- (3) Disconnect differential pressure switch wire from the combination valve.
- (4) Remove mounting nuts from the combination valve bracket and remove the valve (Fig. 20).
- (5) Remove mounting nuts from the master cylinder (Fig. 21).
- (6) Remove master cylinder.
- (7) Remove cylinder cover and drain fluid.

- (8) If master cylinder reservoir requires service, refer to reservoir replacement procedure in this section.



80ad2f20

**Fig. 21 Master Cylinder**

**INSTALLATION**

**NOTE:** If master cylinder is replaced, bleed cylinder before installation.

- (1) Remove protective sleeve from primary piston shank on new master cylinder.
- (2) Clean cylinder mounting surface of brake booster.
- (3) Install master cylinder onto brake booster studs.
- (4) Install mounting nuts and tighten to 17.5 N·m (155 in. lbs.).
- (5) Install combination valve and install mounting nuts.
- (6) Connect brake lines to master cylinder and combination valve and tighten to 19 N·m (170 in. lbs.).
- (7) Connect differential pressure switch wire to the combination valve.
- (8) On RHD vehicles install the coolant reserve/overflow tank. Refer to Group 7 Cooling System.
- (9) Fill and bleed base brake system.

**POWER BRAKE BOOSTER**

**REMOVAL**

- (1) On RHD vehicles remove the coolant reserve/overflow tank. Refer to Group 7 Cooling System.
- (2) Disconnect brake lines at master cylinder.
- (3) Disconnect wire at combination valve differential pressure switch.
- (4) Remove nut mounting combination valve bracket to booster studs and remove valve.
- (5) Remove nuts mounting master cylinder to booster studs and remove cylinder.

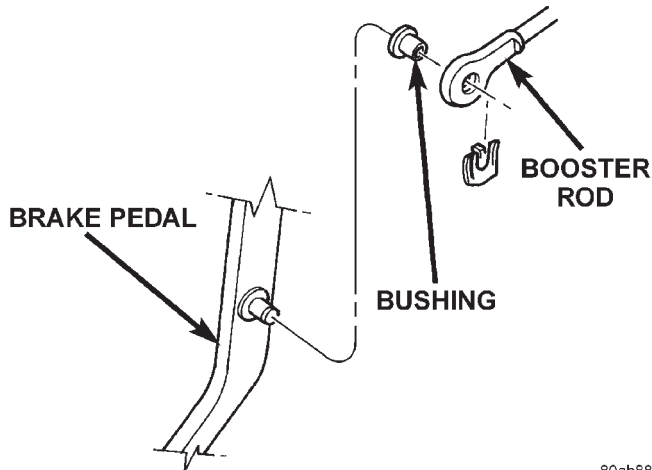
## REMOVAL AND INSTALLATION (Continued)

(6) Disconnect vacuum hose from booster check valve.

(7) Remove knee blocker under the steering column.

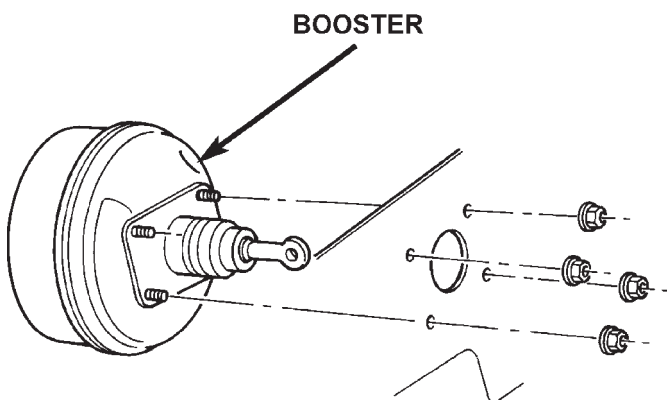
(8) Remove retaining clip that secures booster push rod to brake pedal (Fig. 22).

(9) Remove nuts attaching booster to passenger compartment side of dash panel (Fig. 23).



80ab88a7

Fig. 22 Booster Push Rod



80ab88a8

Fig. 23 Booster Mounting

(10) In engine compartment, slide booster studs out of dash panel, tilt booster upward, and remove booster from engine compartment.

(11) Remove dash seal from booster.

### INSTALLATION

(1) Install dash seal on booster.

(2) Align and position booster on dash panel.

(3) In passenger compartment, install booster mounting nuts. Tighten nuts just enough to hold booster in place.

(4) Slide booster push rod onto the brake pedal. Then secure push rod to pedal pin with retaining clip.

**NOTE: Lubricate the pedal pin and bushing with Mopar multi-mileage grease before installation.**

(5) Tighten booster mounting nuts to 39 N·m (29 ft. lbs.).

(6) Install the knee blocker.

(7) If original master cylinder is being installed, check condition of seal at rear of master cylinder. Replace seal if cut, or torn.

(8) Clean cylinder mounting surface of brake booster. Use shop towel wetted with brake cleaner for this purpose. Dirt, grease, or similar materials will prevent proper cylinder seating and could result in vacuum leak.

(9) Align and install master cylinder on booster studs. Install mounting nuts and tighten to 17.5 N·m (155 in. lbs.).

(10) Connect vacuum hose to booster check valve.

(11) Connect and secure brake lines to combination valve and master cylinder. Start all brake line fittings by hand to avoid cross threading.

(12) Install combination valve on booster studs. Tighten bracket mounting nuts to 17.5 N·m (155 in. lbs.).

(13) Connect wire to combination valve switch.

(14) On RHD vehicles install the coolant reserve/overflow tank. Refer to Group 7 Cooling System.

(15) Fill and bleed base brake system.

(16) Verify proper brake operation before moving vehicle.

## FRONT DISC BRAKE CALIPER

### REMOVAL

(1) Raise and support vehicle.

(2) Remove front wheel and tire assembly.

(3) Drain small amount of fluid from master cylinder brake reservoir with suction gun.

(4) Bottom caliper piston in bore with C-clamp. Position clamp screw on outboard brake shoe and clamp frame on rear of caliper (Fig. 24). **Do not allow clamp screw to bear directly on outboard shoe retainer spring. Use wood or metal spacer between shoe and clamp screw.**

(5) Remove brake hose mounting bolt and discard washers (Fig. 25).

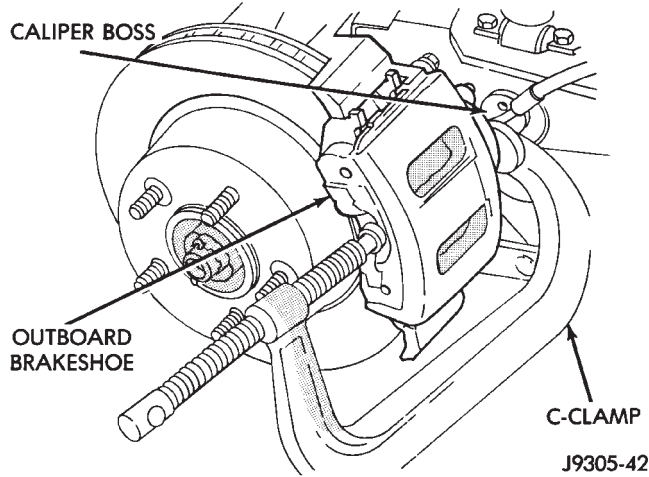
(6) Remove caliper mounting bolts (Fig. 26).

(7) Tilt top of caliper outward with pry tool if necessary (Fig. 27) and remove caliper.

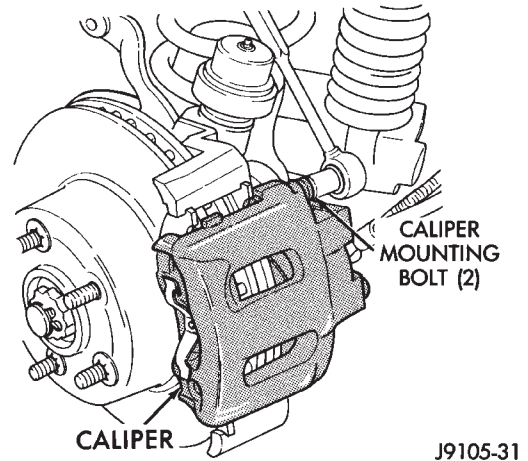
(8) Remove caliper from vehicle.



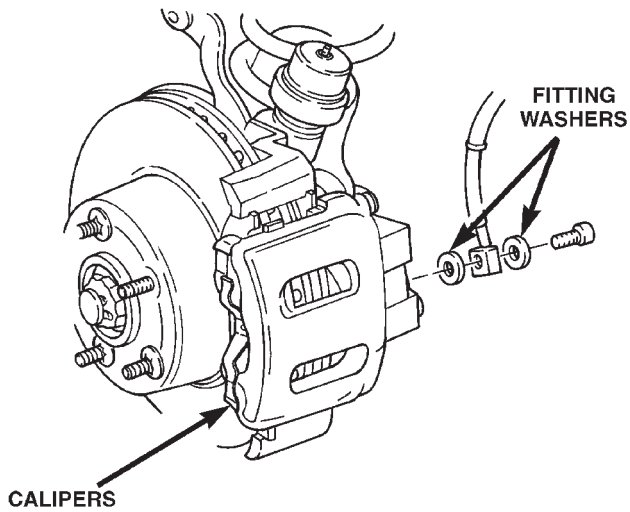
REMOVAL AND INSTALLATION (Continued)



**Fig. 24** *Bottoming Caliper Piston With C-Clamp*



**Fig. 26** *Caliper Mounting Bolts*



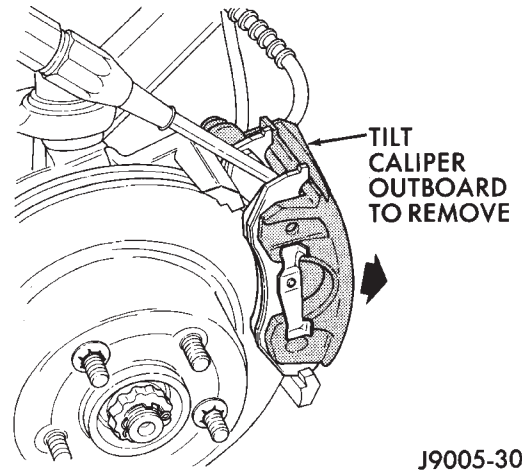
**Fig. 25** *Brake Hose And Bolt*

**INSTALLATION**

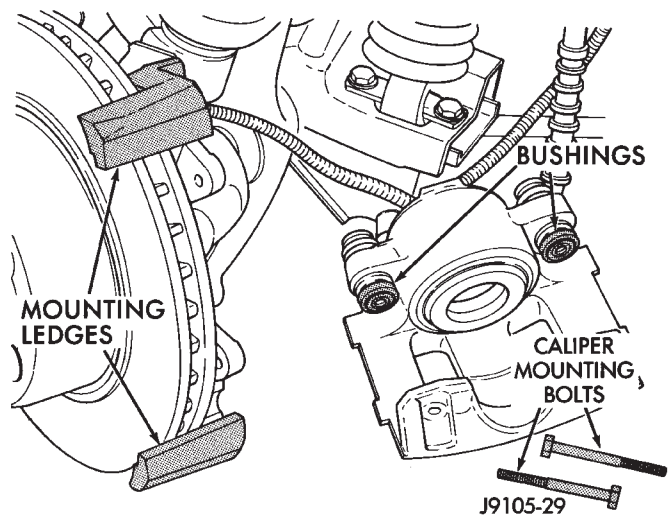
(1) Clean brake shoe mounting ledges with wire brush and apply light coat of Mopar multi-mileage grease to surfaces (Fig. 28).

(2) Install caliper by position notches at lower end of brake shoes on bottom mounting ledge. Then rotate caliper over rotor and seat notches at upper end of shoes on top mounting ledge (Fig. 29).

(3) Coat caliper mounting bolts with silicone grease. Then install and tighten bolts to 15 N·m (11 ft. lbs.).

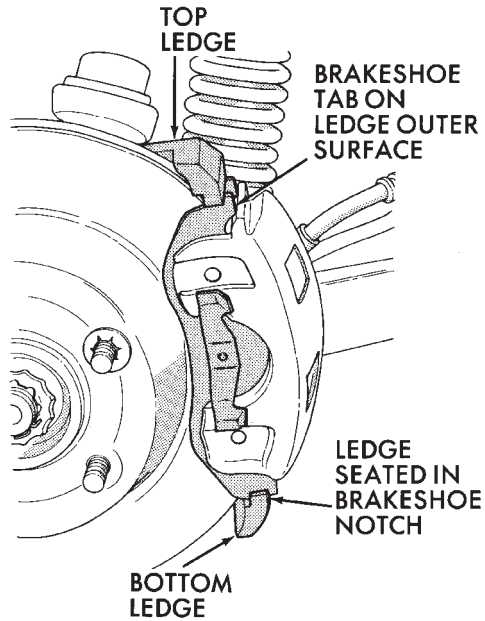


**Fig. 27** *Caliper Removal*



**Fig. 28** *Caliper Lubrication Points*

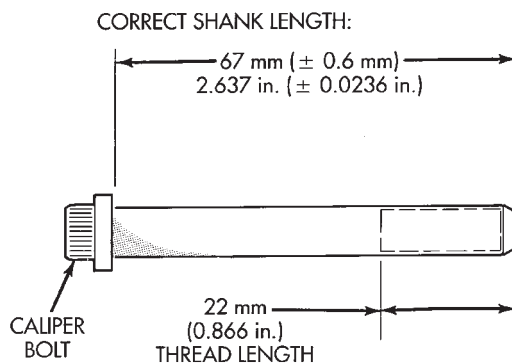
## REMOVAL AND INSTALLATION (Continued)



J9005-35

**Fig. 29 Caliper Installation**

**CAUTION:** If new caliper bolts are being installed, or if the original reason for repair was a drag/pull condition, check caliper bolt length before proceeding. Bolts must not have a shank length greater than 67.6 mm (2.66 in.) (Fig. 30).



J9405-154

**Fig. 30 Mounting Bolt Dimensions**

(4) Install brake hose to caliper with **new seal washers** and tighten fitting bolt to 31 N·m (23 ft. lbs.).

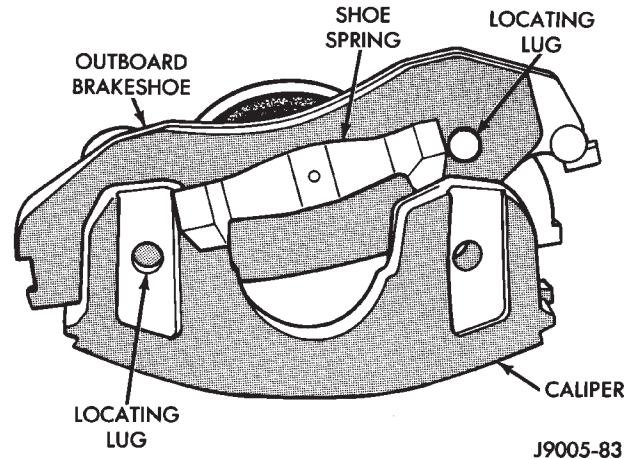
**CAUTION:** Verify brake hose is not twisted or kinked before tightening fitting bolt.

- (5) Bleed base brake system.
- (6) Install wheel and tire assemblies.
- (7) Remove supports and lower vehicle.
- (8) Verify firm pedal before moving vehicle.

## FRONT DISC BRAKE SHOES

## REMOVAL

- (1) Raise and support vehicle.
- (2) Remove wheel and tire assembly.
- (3) Remove caliper.
- (4) Pressing one end of outboard shoe inward to disengage shoe lug. Then rotate shoe upward until retainer spring clears caliper. Press opposite end of shoe inward to disengage shoe lug and rotate shoe up and out of caliper (Fig. 31).

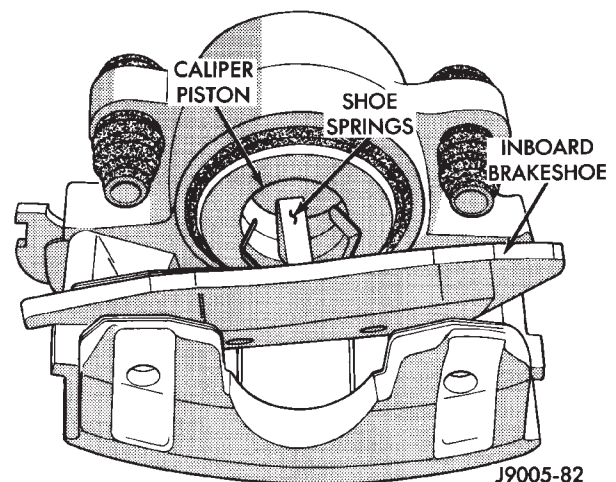


J9005-83

**Fig. 31 Outboard Brake Shoe Removal**

- (5) Grasp ends of inboard shoe and tilt shoe outward to release springs from caliper piston (Fig. 32) and remove shoe from caliper.

**NOTE:** If original brake shoes will be used, keep them in sets left and right. They are not interchangeable.



J9005-82

**Fig. 32 Inboard Brake Shoe Removal**

- (6) Secure caliper to nearby suspension part with wire. **Do not allow brake hose to support caliper weight.**

## REMOVAL AND INSTALLATION (Continued)

- (7) Wipe caliper off with shop rags or towels.

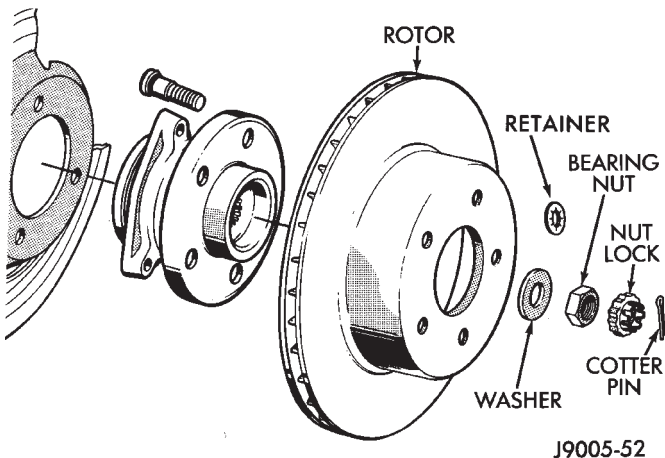
**CAUTION:** Do not use compressed air, this can unseat dust boot and force dirt into piston bore.

**INSTALLATION**

- (1) Install inboard shoe in caliper and verify shoe retaining is fully seated into the piston.
- (2) Starting one end of outboard shoe in caliper and rotating shoe downward into place. Verify shoe locating lugs and shoe spring are seated.
- (3) Install caliper.
- (4) Install wheel and tire assembly.
- (5) Remove support and lower vehicle.
- (6) Pump brake pedal until caliper pistons and brake shoes are seated.
- (7) Top off brake fluid level if necessary.

**DISC BRAKE ROTOR****REMOVAL**

- (1) Remove wheel and tire assemble.
- (2) Remove caliper.
- (3) Remove retainers securing rotor to hub studs (Fig. 33).
- (4) Remove rotor from hub.
- (5) If rotor shield requires service, remove front hub and bearing assembly.



**Fig. 33 Rotor & Hub**

**INSTALLATION**

- (1) If new rotor is being installed, remove protective coating from rotor surfaces with carburetor cleaner.
- (2) Install rotor on hub.
- (3) Install caliper.
- (4) Install wheel and tire assembly.

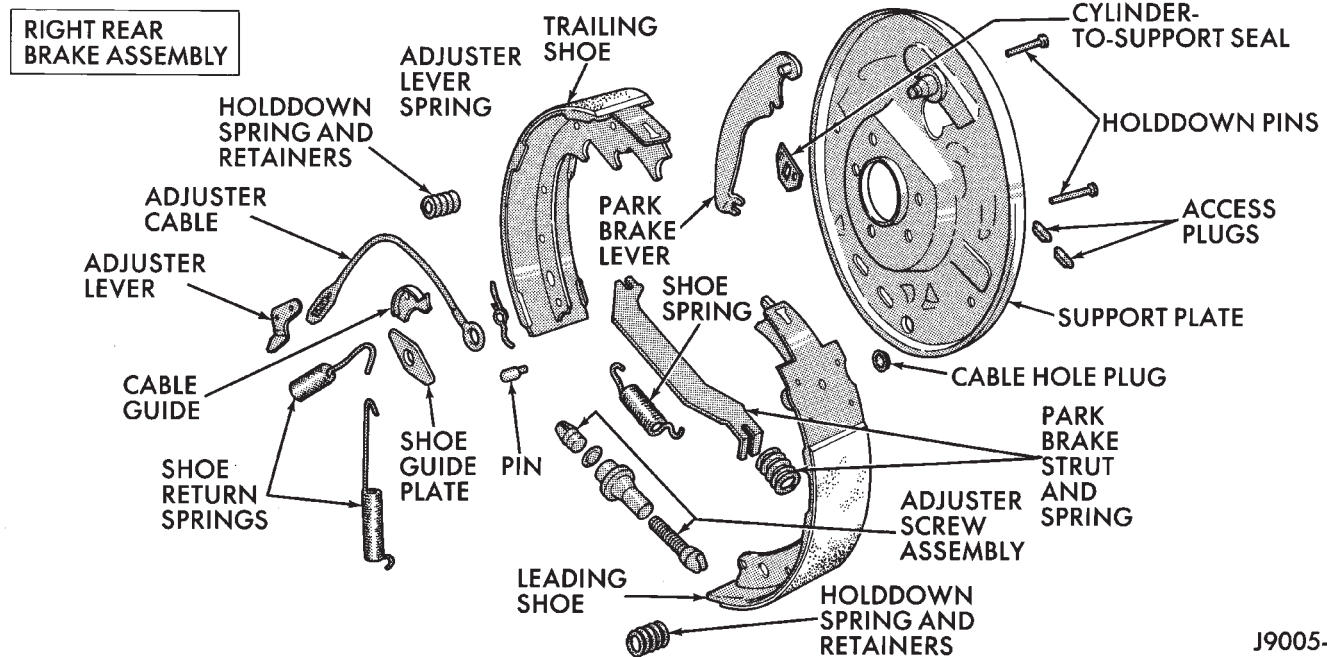
**DRUM BRAKE SHOES****REMOVAL**

- (1) Raise vehicle and remove rear wheels.
- (2) Remove and discard spring nuts securing drums to wheel studs.
- (3) Remove brake drums. If drums prove difficult to remove, retract brake shoes. Remove access plug at the rear of backing plate and back off adjuster screw with brake tool and screwdriver.
- (4) Remove U-clip and washer securing adjuster cable to parking brake lever (Fig. 34).
- (5) Remove primary and secondary return springs from anchor pin with brake spring pliers.
- (6) Remove hold-down springs, retainers and pins with standard retaining spring tool.
- (7) Install spring clamps on wheel cylinders to hold pistons in place.
- (8) Remove adjuster lever, adjuster screw and spring.
- (9) Remove adjuster cable and cable guide.
- (10) Remove brake shoes and parking brake strut.
- (11) Disconnect cable from parking brake lever and remove lever.

**INSTALLATION**

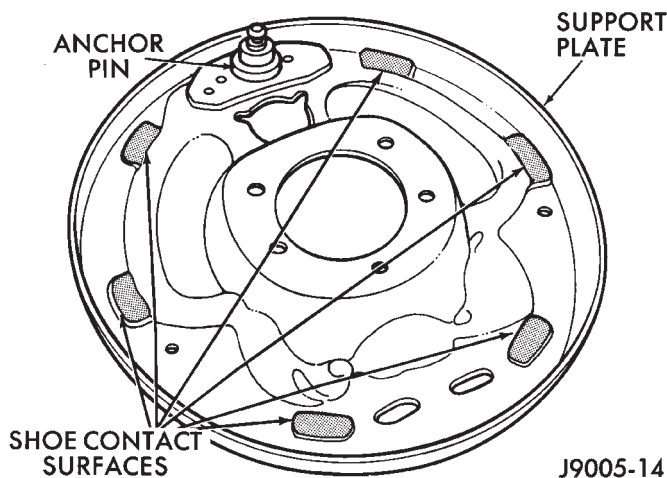
- (1) Clean support plate with brake cleaner.
- (2) If new drums are being installed, remove protective coating with carburetor cleaner followed by final rinse with brake cleaner.
- (3) Clean and lubricate anchor pin with light coat of Mopar multi-mileage grease.
- (4) Apply Mopar multi-mileage grease to brake shoe contact surfaces of support plate (Fig. 35).
- (5) Lubricate adjuster screw threads and pivot with spray lube.
- (6) Attach parking brake lever to secondary brake shoe. Use new washer and U-clip to secure lever.
- (7) Remove wheel cylinder clamps.
- (8) Attach parking brake cable to lever.
- (9) Install brake shoes on support plate. Secure shoes with new hold-down springs, pins and retainers.
- (10) Install parking brake strut and spring.
- (11) Install guide plate and adjuster cable on anchor pin.
- (12) Install primary and secondary return springs.
- (13) Install adjuster cable guide on secondary shoe.
- (14) Lubricate and assemble adjuster screw.
- (15) Install adjuster screw, spring and lever and connect to adjuster cable.
- (16) Adjust shoes to drum.
- (17) Install wheel/tire assemblies and lower vehicle.
- (18) Verify firm brake pedal before moving vehicle.

## REMOVAL AND INSTALLATION (Continued)



J9005-13

Fig. 34 Drum Brake Components—Typical



J9005-14

Fig. 35 Shoe Contact Surfaces

## WHEEL CYLINDER

## REMOVAL

- (1) Remove wheel and tire assembly.
- (2) Remove brake drum.
- (3) Disconnect wheel cylinder brake line.
- (4) Remove brake shoe return springs and move shoes out of engagement with cylinder push rods.
- (5) Remove cylinder attaching bolts and remove cylinder from support plate.

## INSTALLATION

- (1) Apply bead of silicone sealer around cylinder mounting surface of support plate.
- (2) Install cylinder mounting bolts and tighten to 20 N·m (15 ft. lbs.).

- (3) Connect brake line to cylinder.
- (4) Install brake shoe return spring.
- (5) Install brake drum.
- (6) Install wheel and tire assembly.
- (7) Bleed base brake system.

## BRAKE SUPPORT PLATE

## REMOVAL

- (1) Remove wheel and tire assembly and brake drum.
- (2) Remove brake shoe assembly.
- (3) Remove parking brake cable from parking brake lever.
- (4) Compress parking brake cable retainer tabs. Then push retainer and cable through and out of support plate.
- (5) Disconnect brake line at wheel cylinder.
- (6) Remove wheel cylinder from support plate.
- (7) Remove axle shaft, refer to Group 3 for procedures.
- (8) Remove bolts attaching support plate to axle and remove support plate.

## INSTALLATION

- (1) Apply bead of silicone sealer around axle mounting surface of support plate.
- (2) Install support plate on axle flange. Tighten attaching bolts to 115 N·m (85 ft. lbs.).
- (3) Apply bead of silicone sealer around wheel cylinder mounting surface and install wheel cylinder.
- (4) Install brake line in wheel cylinder.
- (5) Install parking brake cable in support plate.

REMOVAL AND INSTALLATION (Continued)

- (6) Install axle shaft, refer to Group 3 for procedure.
- (7) Connect parking brake cable to lever on secondary shoe and install brake shoes on support plate.
- (8) Adjust brake shoes to drum with brake gauge.
- (9) Install brake drum and wheel and tire assembly.
- (10) Bleed brake system.

REAR PARKING BRAKE CABLES

REMOVAL

- (1) Raise vehicle and loosen equalizer nuts until rear cables are slack.
- (2) Disengage cables from equalizer and compress cable retainers with a worm drive hose clamp.
- (3) Remove cables from the cable bracket (Fig. 36).
- (4) Remove rear wheel and brake drums.
- (5) Remove secondary brake shoe and disconnect cable from lever on brake shoe.
- (6) Compress cables retainer with worm drive hose clamp (Fig. 37) and remove cables from backing plates.

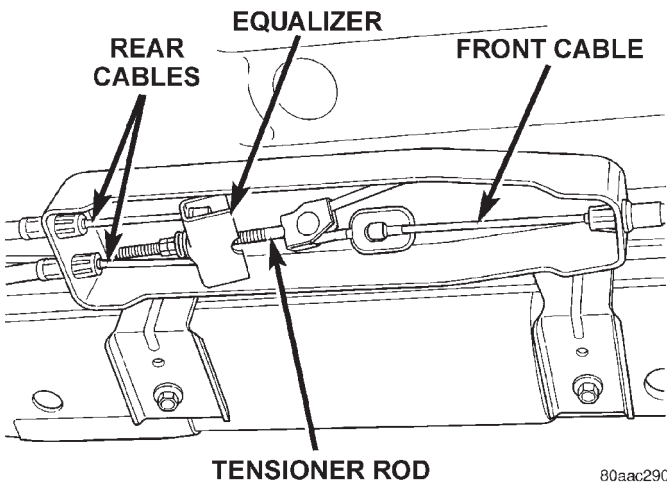


Fig. 36 Parking Brake Cables

INSTALLATION

- (1) Install new cables in backing plates. Be sure cable retainer is seated.
- (2) Attach cable to lever on brake shoe and install brake shoe on backing plate.
- (3) Adjust brake shoes to drum with brake gauge.
- (4) Install brake drums and wheels.
- (5) Install cables into the cable bracket and insure retainers are seated in the bracket.
- (6) Engage the cable ends into the equalizer and install equalizer nut.
- (7) Adjust parking brakes.

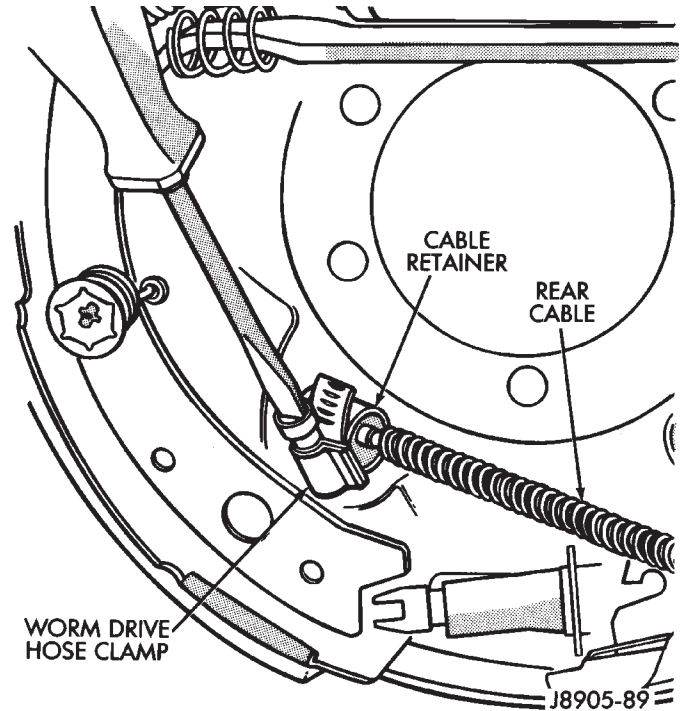


Fig. 37 Cable Retainer

PARKING BRAKE LEVER

The center console must be removed to service the parking brake lever. Refer to Group 23 Interior Components for service procedures.

REMOVAL

- (1) Release parking brakes.
- (2) Raise vehicle.
- (3) Remove adjusting nut from tensioner rod at the equalizer (Fig. 38).

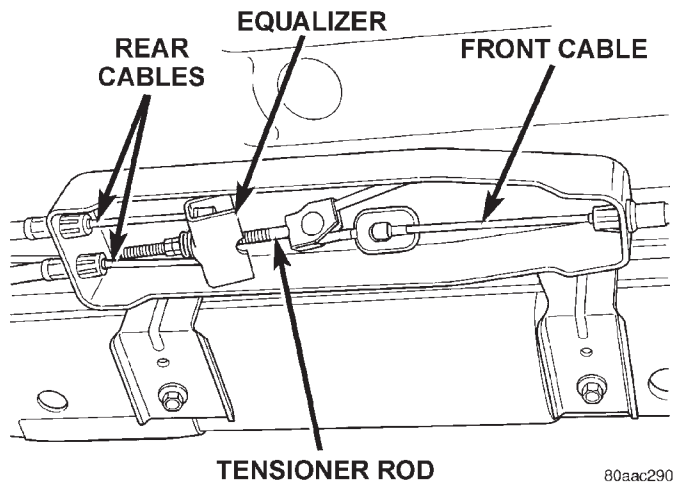


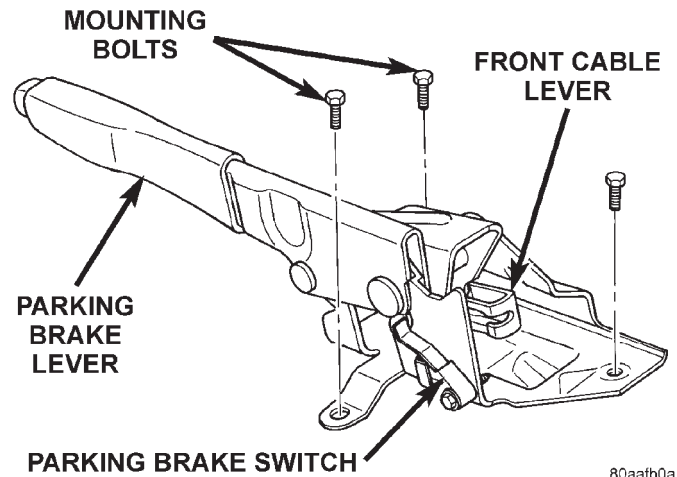
Fig. 38 Parking Brake Equalizer

- (4) Lower vehicle.
- (5) Disengage front cable from the cable lever.

## REMOVAL AND INSTALLATION (Continued)

(6) Compress cable retainer with worm drive hose clamp and remove the cable from the parking brake lever base.

(7) Disconnect parking brake lamp switch wire (Fig. 39).



80aafb0a

**Fig. 39 Parking Brake Lever Assembly**

(8) Remove parking brake lever assembly mounting bolts (Fig. 39).

(9) Remove lever assembly.

(10) Remove parking brake lamp switch.

## INSTALLATION

(1) Install parking brake lamp switch.

(2) Position lever assembly on floorpan and install lever mounting bolts.

(3) Tighten lever mounting bolts to 10 to 14 N·m (7 to 10 ft. lbs.).

(4) Insert front cable through the parking brake lever base. Insure the cable retainer is seated into the base.

(5) Attach the front cable to the cable lever (Fig. 39).

(6) Connect parking brake lamp switch wire.

(7) Raise vehicle.

(8) Install adjusting nut to the tensioner rod and adjust parking brakes.

(9) Lower vehicle.

(10) Verify correct parking brake operation.

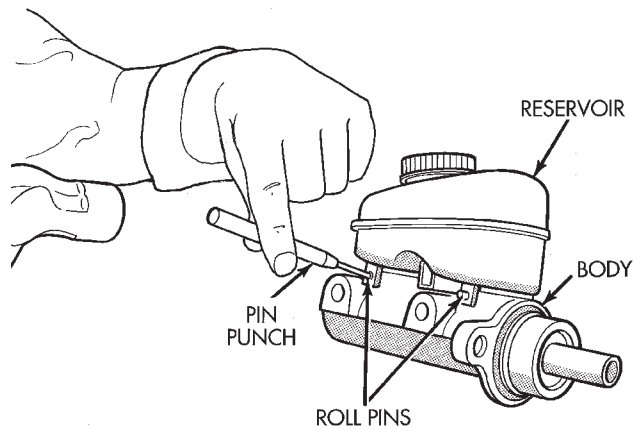
## DISASSEMBLY AND ASSEMBLY

## MASTER CYLINDER RESERVOIR

## REMOVAL

(1) Remove reservoir cap and empty fluid into drain container.

(2) Remove pins that retain reservoir to master cylinder. Use hammer and pin punch to remove pins (Fig. 40).

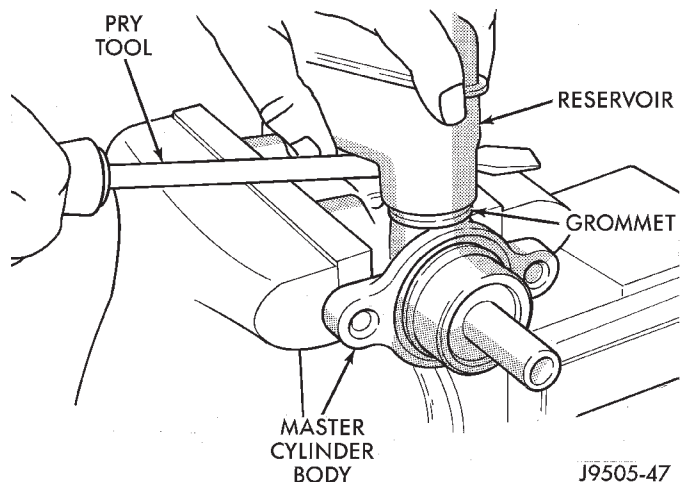


J9505-77

**Fig. 40 Reservoir Retaining Pins**

(3) Clamp cylinder body in vise with brass protective jaws.

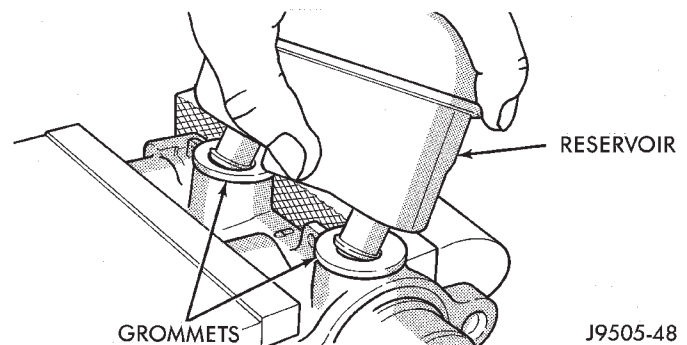
(4) Loosen reservoir from grommets with pry tool (Fig. 41).



J9505-47

**Fig. 41 Loosening Reservoir**

(5) Remove reservoir by rocking it to one side and pulling free of grommets (Fig. 42).



J9505-48

**Fig. 42 Reservoir Removal**

DISASSEMBLY AND ASSEMBLY (Continued)

(6) Remove old grommets from cylinder body (Fig. 43).

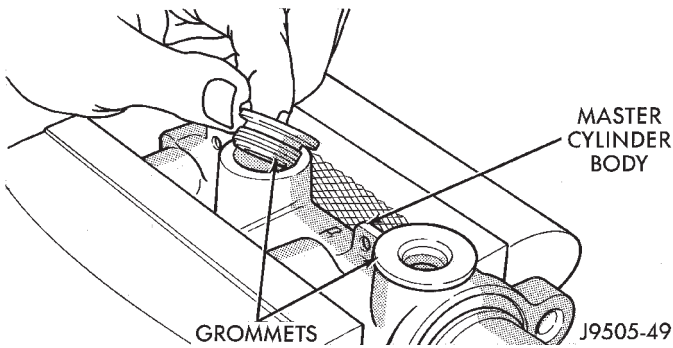


Fig. 43 Grommet Removal

INSTALLATION

**CAUTION:** Do not use any type of tool to install the grommets. Tools may cut, or tear the grommets creating a leak problem after installation. Install the grommets using finger pressure only.

(1) Lubricate new grommets with clean brake fluid and install new grommets in cylinder body (Fig. 44). Use finger pressure to install and seat grommets.

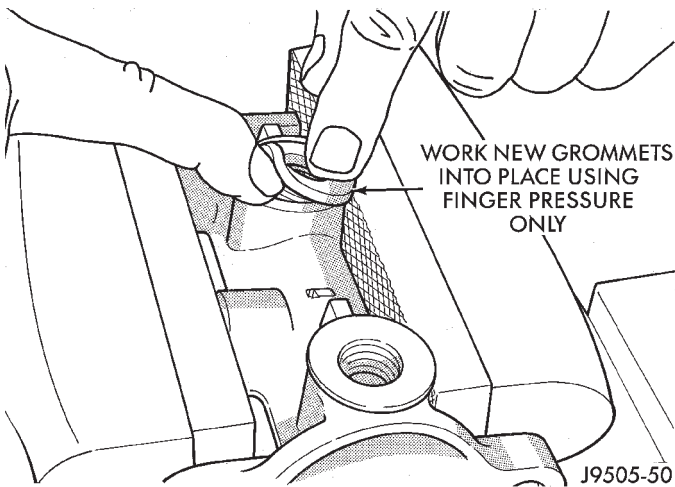


Fig. 44 Grommet Installation

(2) Start reservoir in grommets. Then rock reservoir back and forth while pressing downward to seat it in grommets.

(3) Install pins that retain reservoir to cylinder body.

(4) Fill and bleed master cylinder on bench before installation in vehicle.

DISC BRAKE CALIPER

DISASSEMBLY

- (1) Remove brake shoes from caliper.
- (2) Drain brake fluid out of caliper.
- (3) Take a piece of wood and pad it with one-inch thickness of shop towels. Place this piece in the out-

board shoe side of the caliper in front of the piston. This will cushion and protect caliper piston during removal (Fig. 45).

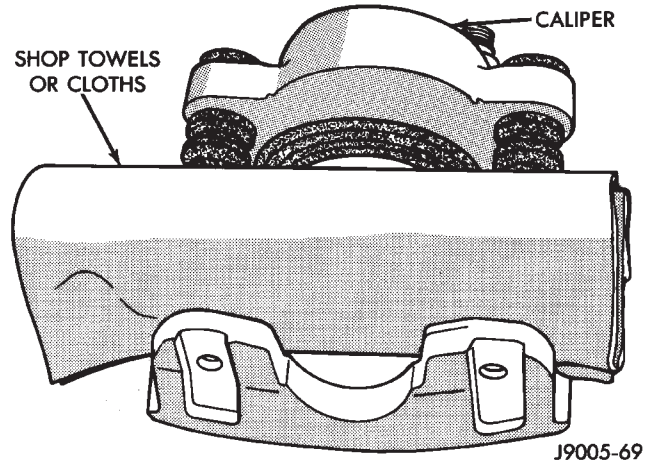


Fig. 45 Padding Caliper Interior

(4) Remove caliper piston with **short bursts** of low pressure compressed air. Direct air through fluid inlet port and ease piston out of bore (Fig. 46).

**CAUTION:** Do not blow the piston out of the bore with sustained air pressure. This could result in a cracked piston. Use only enough air pressure to ease the piston out.

**WARNING: NEVER ATTEMPT TO CATCH THE PISTON AS IT LEAVES THE BORE. THIS MAY RESULT IN PERSONAL INJURY.**

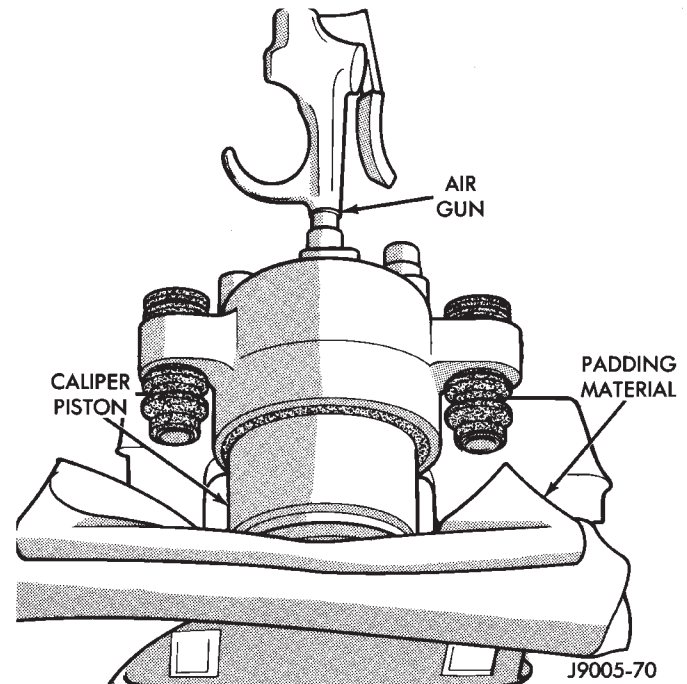
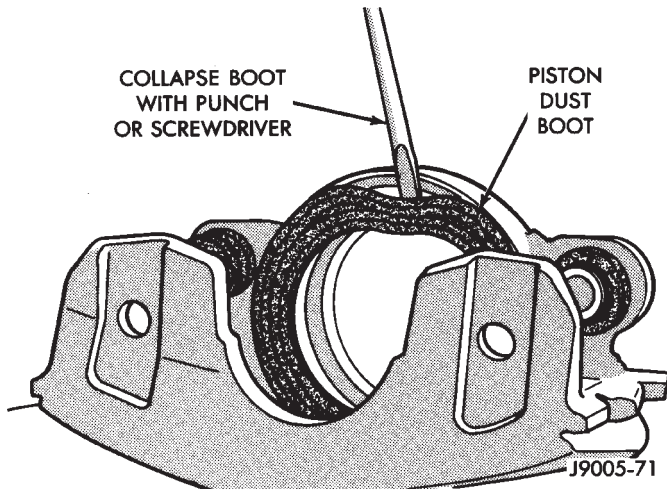


Fig. 46 Caliper Piston Removal

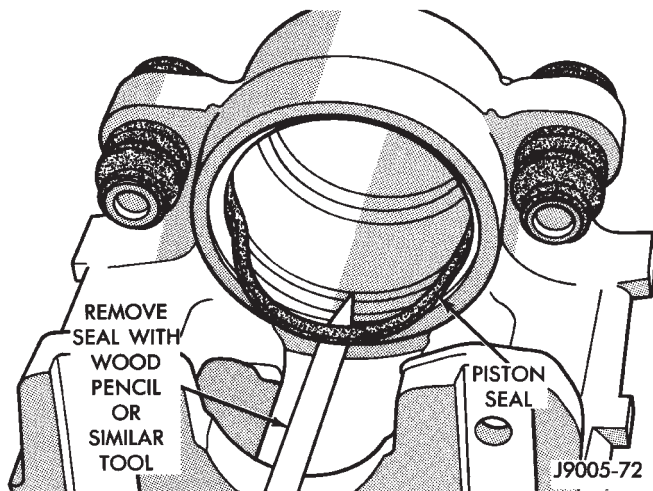
## DISASSEMBLY AND ASSEMBLY (Continued)

(5) Remove caliper piston dust boot with suitable pry tool (Fig. 47).



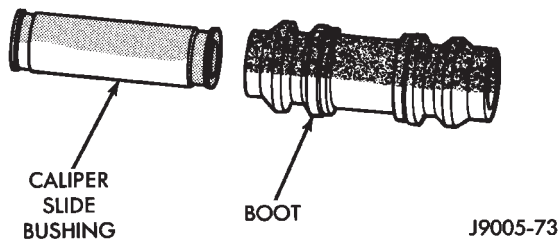
**Fig. 47 Caliper Piston Dust Boot Removal**

(6) Remove caliper piston seal with wood or plastic tool (Fig. 48). Do not use metal tools as they will scratch piston bore.



**Fig. 48 Piston Seal Removal**

(7) Remove caliper mounting bolt bushings and boots (Fig. 49).

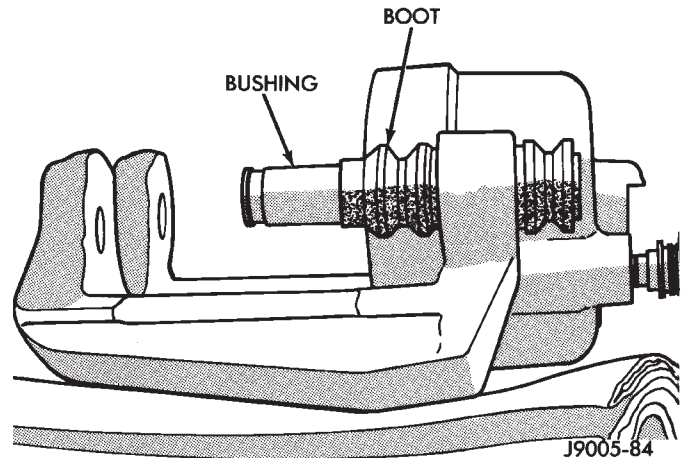


**Fig. 49 Mounting Bolt Bushing And Boot**

## ASSEMBLY

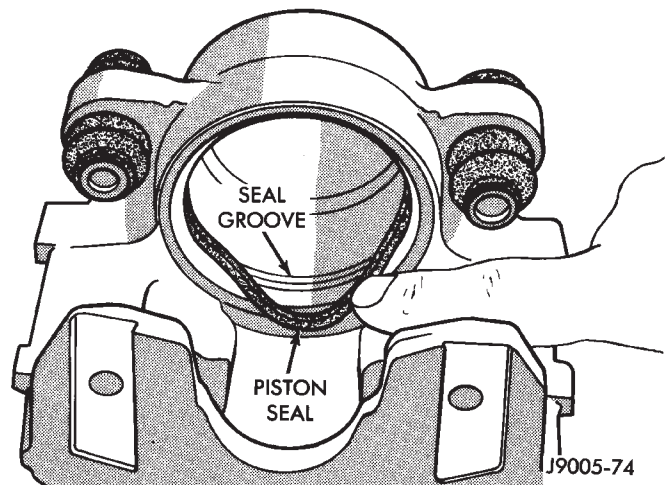
**CAUTION:** Dirt, oil, and solvents can damage caliper seals. Insure assembly area is clean and dry.

- (1) Lubricate caliper piston bore, new piston seal and piston with clean brake fluid.
- (2) Lubricate caliper bushings and interior of bushing boots with silicone grease.
- (3) Install bushing boots in caliper, then insert bushing into boot and push bushing into place (Fig. 50).



**Fig. 50 Bushings And Boots Installation**

(4) Install new piston seal into seal groove with finger (Fig. 51).

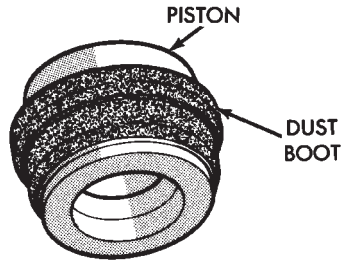


**Fig. 51 Piston Seal Installation**

- (5) Install new dust boot on caliper piston and seat boot in piston groove (Fig. 52).
- (6) Press piston into caliper bore by hand, use a turn and push motion to work piston into seal (Fig. 53).
- (7) Press caliper piston to bottom of bore.
- (8) Seat dust boot in caliper with Installer Tool C-4842 and Tool Handle C-4171 (Fig. 54).



DISASSEMBLY AND ASSEMBLY (Continued)



J9005-75

Fig. 52 Dust Boot On Piston

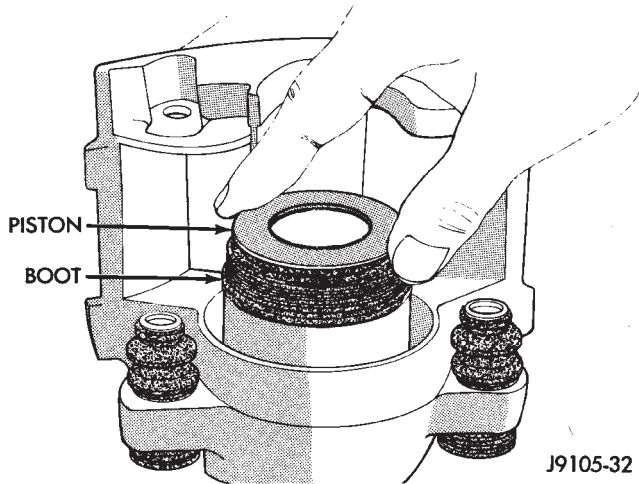


Fig. 53 Caliper Piston Installation

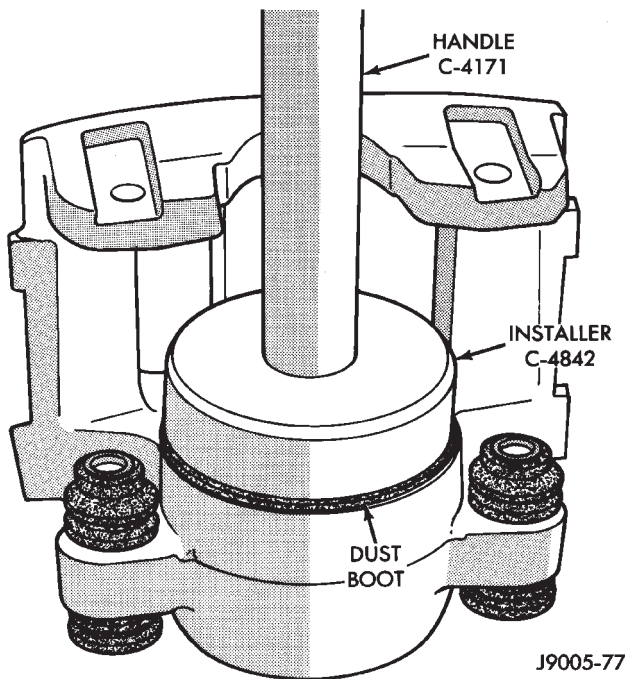


Fig. 54 Piston Dust Boot Installation

(9) Replace caliper bleed screw if removed.

WHEEL CYLINDER

DISASSEMBLY

- (1) Remove push rods and boots (Fig. 55).
- (2) Press pistons, cups and spring and expander out of cylinder bore.
- (3) Remove bleed screw.

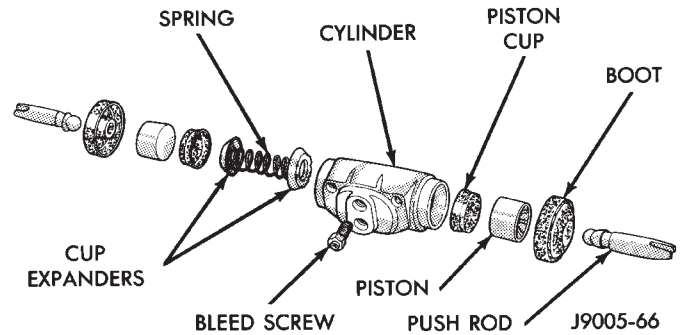


Fig. 55 Wheel Cylinder Components—Typical

ASSEMBLY

- (1) Lubricate wheel cylinder bore, pistons, piston cups and spring and expander with clean brake fluid.
- (2) Install first piston in cylinder bore. Then install first cup in bore and against piston. **Be sure lip of piston cup is facing inward (toward spring and expander) and flat side is against piston.**
- (3) Install spring and expander followed by remaining piston cup and piston.
- (4) Install boots on each end of cylinder and insert push rods in boots.
- (5) Install cylinder bleed screw.

CLEANING AND INSPECTION

CALIPER

CLEANING

Clean the caliper components with clean brake fluid or brake clean only. Wipe the caliper and piston dry with lint free towels or use low pressure compressed air.

**CAUTION:** Do not use gasoline, kerosene, thinner, or similar solvents. These products may leave a residue that could damage the piston and seal.

INSPECTION

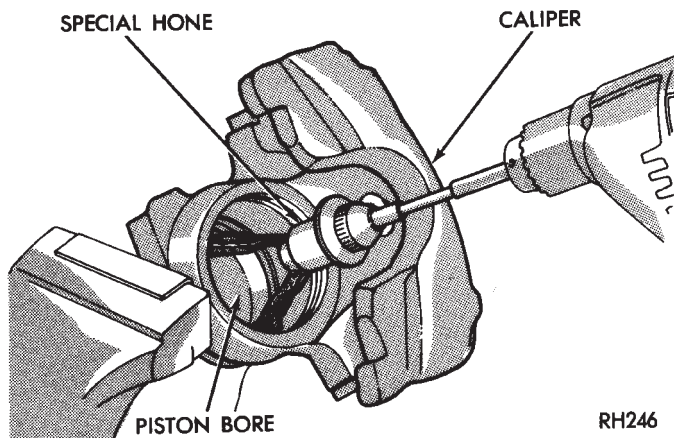
The piston is made from a phenolic resin (plastic material) and should be smooth and clean.

The piston must be replaced if cracked or scored. Do not attempt to restore a scored piston surface by sanding or polishing.

## CLEANING AND INSPECTION (Continued)

**CAUTION:** If the caliper piston is replaced, install the same type of piston in the caliper. Never interchange phenolic resin and steel caliper pistons. The pistons, seals, seal grooves, caliper bore and piston tolerances are different.

The bore can be **lightly** polished with a brake hone to remove very minor surface imperfections (Fig. 56). The caliper should be replaced if the bore is severely corroded, rusted, scored, or if polishing would increase bore diameter more than 0.025 mm (0.001 inch).



RH246

**Fig. 56 Polishing Piston Bore**

## REAR DRUM BRAKE

## CLEANING

Clean the individual brake components, including the support plate and wheel cylinder exterior, with a water dampened cloth or with brake cleaner. Do not use any other cleaning agents. Remove light rust and scale from the brake shoe contact pads on the support plate with fine sandpaper.

## INSPECTION

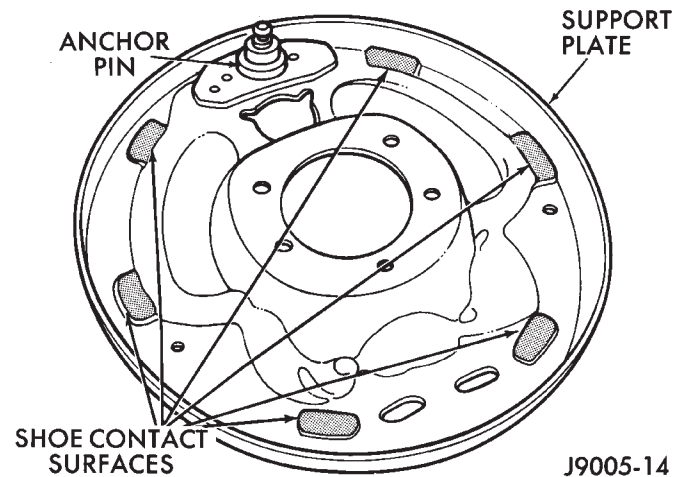
As a general rule, riveted brake shoes should be replaced when worn to within 0.78 mm (1/32 in.) of the rivet heads. Bonded lining should be replaced when worn to a thickness of 1.6 mm (1/16 in.).

Examine the lining contact pattern to determine if the shoes are bent or the drum is tapered. The lining should exhibit contact across its entire width. Shoes exhibiting contact only on one side should be replaced and the drum checked for runout or taper.

Inspect the adjuster screw assembly. Replace the assembly if the star wheel or threads are damaged, or the components are severely rusted or corroded.

Discard the brake springs and retainer components if worn, distorted or collapsed. Also replace the springs if a brake drag condition had occurred. Overheating will distort and weaken the springs.

Inspect the brake shoe contact pads on the support plate, replace the support plate if any of the pads are worn or rusted through. Also replace the plate if it is bent or distorted (Fig. 57).



**Fig. 57 Shoe Contact Surfaces**

## WHEEL CYLINDER

## CLEANING

Clean the cylinder and pistons with clean brake fluid or brake cleaner only. Do not use any other cleaning agents.

Dry the cylinder and pistons with compressed air. Do not use rags or shop towels to dry the cylinder components. Lint from cloth material will adhere to the cylinder bores and pistons.

## INSPECTION

Inspect the cylinder bore. Light discoloration and dark stains in the bore are normal and will not impair cylinder operation.

The cylinder bore can be lightly polished but only with crocus cloth. Replace the cylinder if the bore is scored, pitted or heavily corroded. Honing the bore to restore the surface is not recommended.

Inspect the cylinder pistons. The piston surfaces should be smooth and free of scratches, scoring and corrosion. Replace the pistons if worn, scored, or corroded. Do attempt to restore the surface by sanding or polishing.

Discard the old piston cups and the spring and expander. These parts are not reusable. The original dust boots may be reused but only if they are in good condition.

## ADJUSTMENTS

## STOP LAMP SWITCH

(1) Press and hold brake pedal in applied position.

## ADJUSTMENTS (Continued)

(2) Pull switch plunger all the way out to fully extended position.

(3) Release brake pedal. Then pull pedal fully rearward. Pedal will set plunger to correct position as pedal pushes plunger into switch body. Switch will make ratcheting sound as it self adjusts.

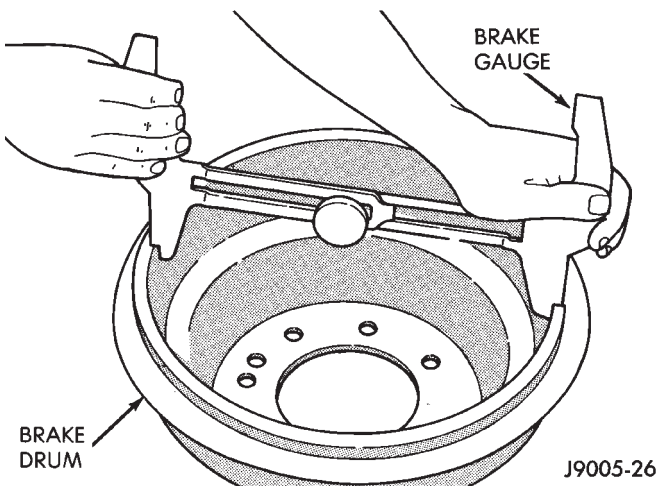
## REAR DRUM BRAKE

The rear drum brakes are equipped with a self-adjusting mechanism. Under normal circumstances, the only time adjustment is required is when the shoes are replaced, removed for access to other parts, or when one or both drums are replaced.

Adjustment can be made with a standard brake gauge or with adjusting tool. Adjustment is performed with the complete brake assembly installed on the backing plate.

## ADJUSTMENT WITH BRAKE GAUGE

- (1) Be sure parking brakes are fully released.
- (2) Raise rear of vehicle and remove wheels and brake drums.
- (3) Verify that left and right automatic adjuster levers and cables are properly connected.
- (4) Insert brake gauge in drum. Expand gauge until gauge inner legs contact drum braking surface. Then lock gauge in position (Fig. 58).



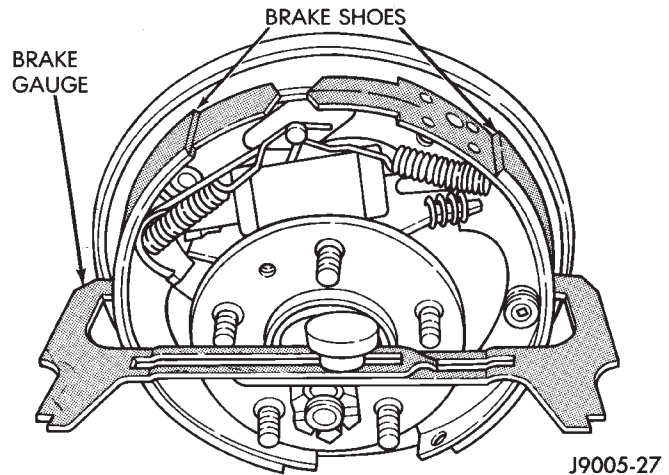
**Fig. 58 Adjusting Gauge On Drum**

(5) Reverse gauge and install it on brake shoes. Position gauge legs at shoe centers as shown (Fig. 59). If gauge does not fit (too loose/too tight), adjust shoes.

(6) Pull shoe adjuster lever away from adjuster screw star wheel.

(7) Turn adjuster screw star wheel (by hand) to expand or retract brake shoes. Continue adjustment until gauge outside legs are light drag-fit on shoes.

(8) Install brake drums and wheels and lower vehicle.



**Fig. 59 Adjusting Gauge On Brake Shoes**

- (9) Drive vehicle and make one forward stop followed by one reverse stop. Repeat procedure 8-10 times to operate automatic adjusters and equalize adjustment.

**NOTE:** Bring vehicle to complete standstill at each stop. Incomplete, rolling stops will not activate automatic adjusters.

## ADJUSTMENT WITH ADJUSTING TOOL

- (1) Be sure parking brake lever is fully released.
- (2) Raise vehicle so rear wheels can be rotated freely.
- (3) Remove plug from each access hole in brake support plates.
- (4) Loosen parking brake cable adjustment nut until there is slack in front cable.
- (5) Insert adjusting tool through support plate access hole and engage tool in teeth of adjusting screw star wheel (Fig. 60).
- (6) Rotate adjuster screw star wheel (move tool handle upward) until slight drag can be felt when wheel is rotated.
- (7) Push and hold adjuster lever away from star wheel with thin screwdriver.
- (8) Back off adjuster screw star wheel until brake drag is eliminated.
- (9) Repeat adjustment at opposite wheel. Be sure adjustment is equal at both wheels.
- (10) Install support plate access hole plugs.
- (11) Adjust parking brake cable and lower vehicle.
- (12) Drive vehicle and make one forward stop followed by one reverse stop. Repeat procedure 8-10 times to operate automatic adjusters and equalize adjustment.

## ADJUSTMENTS (Continued)

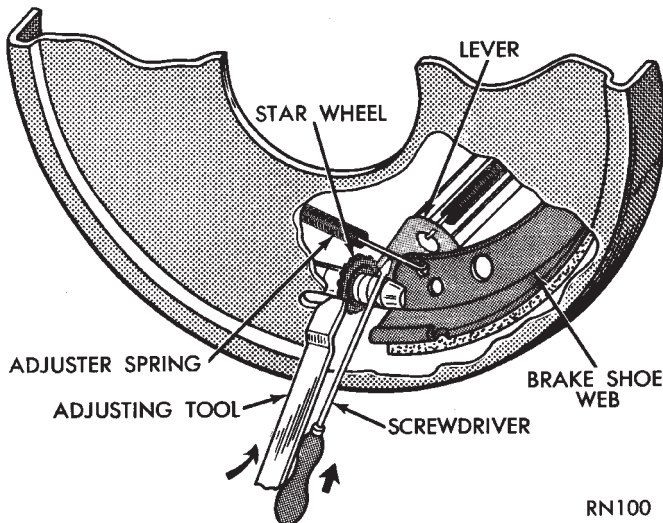


Fig. 60 Brake Adjustment

**NOTE:** Bring vehicle to complete standstill at each stop. Incomplete, rolling stops will not activate automatic adjusters.

## PARKING BRAKE CABLE TENSIONER

**NOTE:** Parking brake adjustment is only necessary when the tensioner, or a cable has been replaced or disconnected.

## ADJUSTMENT

- (1) Raise vehicle.
- (2) Back off tensioner adjusting nut to create slack in cables.
- (3) Remove rear wheel/tire assemblies and remove brake drums.
- (4) Check rear brake shoe adjustment with standard brake gauge.

**CAUTION:** Excessive shoe-to-drum clearance, or worn brake components will result in faulty parking brake adjustment and operation.

(5) Verify that parking brake cables operate freely and are not binding, or seized. Replace faulty cables, before proceeding.

(6) Reinstall brake drums and wheel/tire assemblies after brake shoe adjustment is complete.

(7) Lower vehicle enough for access to parking brake lever. Then **fully** apply parking brakes. Leave brakes applied until adjustment is complete.

(8) Raise vehicle and mark tensioner rod 6.5 mm (1/4 in.) from tensioner bracket (Fig. 61).

(9) Tighten adjusting nut at equalizer until mark on tensioner rod moves into alignment with tensioner bracket.

(10) Lower vehicle until rear wheels are 15-20 cm (6-8 in.) off shop floor.

(11) Release parking brake lever and verify that rear wheels rotate freely without drag.

(12) Lower vehicle.

**NOTE:** Do not loosen/tighten equalizer adjusting nut for any reason after completing adjustment.

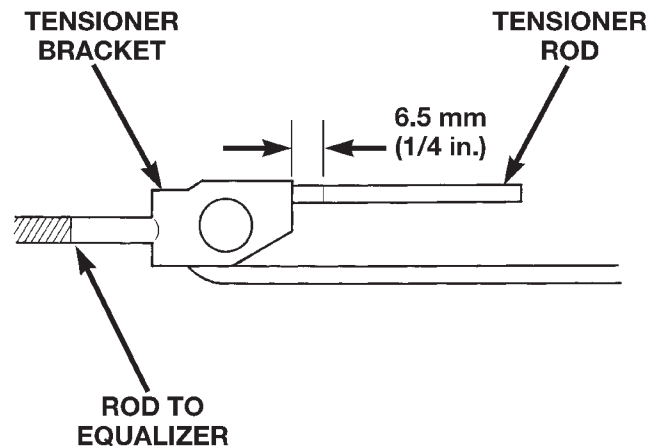


Fig. 61 Tensioner Rod Measurement

## SPECIFICATIONS

## BRAKE FLUID

The brake fluid used in this vehicle must conform to DOT 3 specifications and SAE J1703 standards. No other type of brake fluid is recommended or approved for usage in the vehicle brake system. Use only Mopar brake fluid or an equivalent from a tightly sealed container.

**CAUTION:** Never use reclaimed brake fluid or fluid from an container which has been left open. An open container will absorb moisture from the air and contaminate the fluid.

**CAUTION:** Never use any type of a petroleum-based fluid in the brake hydraulic system. Use of such type fluids will result in seal damage of the vehicle brake hydraulic system causing a failure of the vehicle brake system. Petroleum based fluids would be items such as engine oil, transmission fluid, power steering fluid ect.

SPECIFICATIONS (Continued)

**BRAKE COMPONENTS**

*Disc Brake Caliper*

Type ..... Sliding

**Disc Brake Rotor**

Type ..... Ventilated  
 Max. Runout ..... 0.12 mm  
 (0.005 in.)  
 Max. Thickness Variation ..... 0.013 mm  
 (0.0005 in.)  
 Min. Thickness ..... 22.7 mm  
 (0.8937 in.)

**Brake Drum**

Size ..... 9 in. or 10 in.

**Brake Booster**

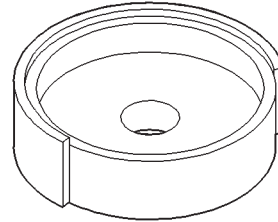
Type ..... Dual Diaphragm

**TORQUE CHART**

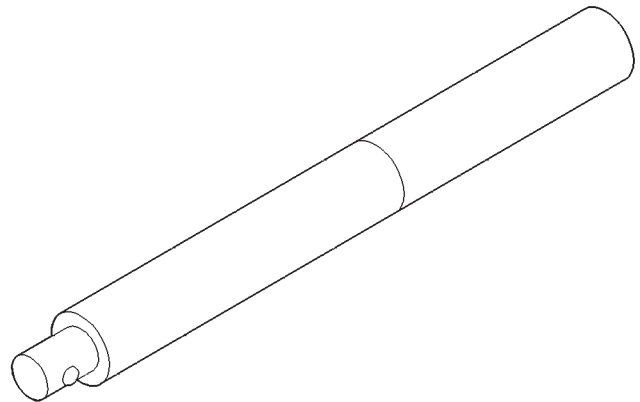
DESCRIPTION	TORQUE
<b>Brake Pedal</b>	
Pivot Bolt/Nut .....	35 N·m (26 ft. lbs.)
<b>Brake Booster</b>	
Mounting Nuts .....	39 N·m (29 ft. lbs.)
<b>Master Cylinder</b>	
Mounting Nuts .....	17.5 N·m (155 in. lbs.)
Brake Lines .....	19 N·m (170 in. lbs.)
<b>Combination Valve</b>	
Mounting Nuts .....	17.5 N·m (155 in. lbs.)
Brake Lines .....	19 N·m (170 in. lbs.)
<b>Caliper</b>	
Mounting Bolts .....	15 N·m (11 ft. lbs.)
Brake Hose Bolt .....	31 N·m (23 ft. lbs.)
<b>Wheel Cylinder</b>	
Mounting Bolts .....	10 N·m (7 ft. lbs.)
Brake Line .....	16 N·m (12 ft. lbs.)
<b>Parking Brake</b>	
Lever Screws .....	10-14 N·m (7-10 ft. lbs.)
Lever Bracket Screws . . .	10-14 N·m (7-10 ft. lbs.)
Cable Retainer Nut .....	1.5 N·m (14 in. lbs.)

SPECIAL TOOLS

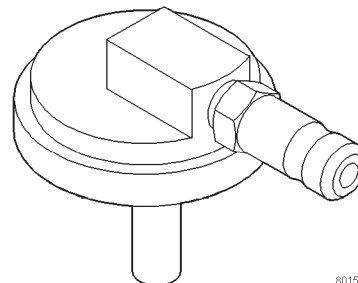
**BASE BRAKES**



*Installer Caliper Dust Boot C-4842*



*Handle C-4171*



8015c88d

*Adapter Pressure Bleeder 6921*

# ANTILOCK BRAKES

## INDEX

	page		page
<b>GENERAL INFORMATION</b>			
ANTILOCK BRAKE SYSTEM .....	30	<b>SERVICE PROCEDURES</b>	
<b>DESCRIPTION AND OPERATION</b>			
ANTILOCK BRAKE SYSTEM .....	30	BLEEDING ABS BRAKE SYSTEM .....	33
CONTROLLER ANTILOCK BRAKES .....	31	<b>REMOVAL AND INSTALLATION</b>	
HYDRAULIC CONTROL UNIT .....	31	HYDRAULIC CONTROL	
WHEEL SPEED SENSORS		UNIT/CONTROLLER ANTILOCK BRAKES .....	33
AND TONE WHEEL .....	32	FRONT WHEEL SPEED SENSOR .....	34
COMBINATION VALVE .....	32	REAR WHEEL SPEED SENSOR .....	34
ACCELERATION SWITCH .....	33	ACCELERATION SWITCH .....	36
ABS WARNING LAMP .....	33	<b>DISASSEMBLY AND ASSEMBLY</b>	
<b>DIAGNOSIS AND TESTING</b>			
ANTILOCK BRAKES .....	33	HYDRAULIC CONTROL UNIT/CONTROLLER	
		ANTILOCK BRAKE .....	36
		<b>SPECIFICATIONS</b>	
		TORQUE CHART .....	37

## GENERAL INFORMATION

### ANTILOCK BRAKE SYSTEM

The antilock brake system (ABS) is an electronically operated, all wheel brake control system.

The system is designed to prevent wheel lockup and maintain steering control during periods of high wheel slip when braking. Preventing lockup is accomplished by modulating fluid pressure to the wheel brake units.

The hydraulic system is a three channel design. The front wheel brakes are controlled individually and the rear wheel brakes in tandem (Fig. 1). The ABS electrical system is separate from other electrical circuits in the vehicle. A specially programmed controller antilock brake unit operates the system components.

ABS system major components include:

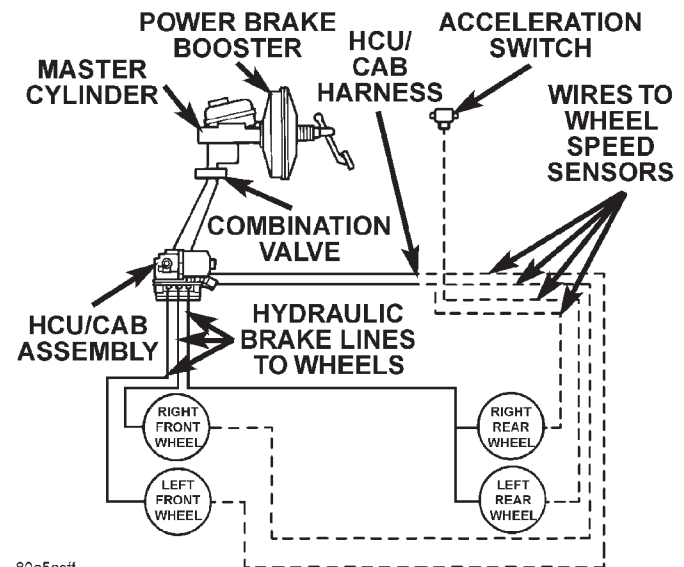
- Controller Antilock Brakes (CAB)
- Hydraulic Control Unit (HCU)
- Wheel Speed Sensors (WSS)
- Acceleration Switch
- ABS Warning Light

## DESCRIPTION AND OPERATION

### ANTILOCK BRAKE SYSTEM

The purpose of the antilock system is to prevent wheel lockup during periods of high wheel slip. Preventing lockup helps maintain vehicle braking action and steering control.

The antilock CAB activates the system whenever sensor signals indicate periods of high wheel slip.



**Fig. 1 Antilock Brake System**

High wheel slip can be described as the point where wheel rotation begins approaching 20 to 30 percent of actual vehicle speed during braking. Periods of high wheel slip occur when brake stops involve high pedal pressure and rate of vehicle deceleration.

Battery voltage is supplied to the CAB ignition terminal when the ignition switch is turned to Run position. The CAB performs a system initialization procedure at this point. Initialization consists of a static and dynamic self check of system electrical components.

The static check occurs after the ignition switch is turned to Run position. The dynamic check occurs when vehicle road speed reaches approximately 30 kph (18 mph). During the dynamic check, the CAB

## DESCRIPTION AND OPERATION (Continued)

briefly cycles the pump and solenoids to verify operation.

If an ABS component exhibits a fault during initialization, the CAB illuminates the amber warning light and registers a fault code in the microprocessor memory.

**NORMAL BRAKING**

During normal braking, the master cylinder, power booster and wheel brake units all function as they would in a vehicle without ABS. The HCU components are not activated.

**ANTILOCK BRAKING**

The antilock system prevents lockup during high slip conditions by modulating fluid apply pressure to the wheel brake units.

Brake fluid apply pressure is modulated according to wheel speed, degree of slip and rate of deceleration. A sensor at each wheel converts wheel speed into electrical signals. These signals are transmitted to the CAB for processing and determination of wheel slip and deceleration rate.

The ABS system has three fluid pressure control channels. The front brakes are controlled separately and the rear brakes in tandem. A speed sensor input signal indicating a high slip condition activates the CAB antilock program.

Two solenoid valves are used in each antilock control channel. The valves are all located within the HCU valve body and work in pairs to either increase, hold, or decrease apply pressure as needed in the individual control channels.

The solenoid valves are not static during antilock braking. They are cycled continuously to modulate pressure. Solenoid cycle time in antilock mode can be measured in milliseconds.

**CONTROLLER ANTILOCK BRAKES**

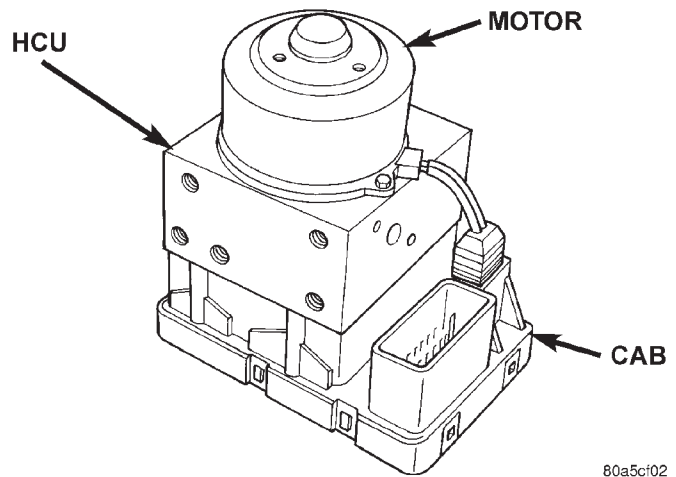
The CAB monitors wheel speed sensor inputs continuously while the vehicle is in motion. However, the CAB will not activate any ABS components as long as sensor inputs and the acceleration switch indicate normal braking.

The CAB is mounted to the HCU and operates the ABS system (Fig. 2) separate from other vehicle electrical circuits. CAB voltage source is through the ignition switch in the RUN position.

The CAB contains dual microprocessors. A logic block in each microprocessor receives identical sensor signals. These signals are processed and compared simultaneously.

The CAB contains a self check program that illuminates the ABS warning light when a system fault is detected. Faults are stored in a diagnostic program memory and are accessible with the DRB scan tool.

ABS faults remain in memory until cleared, or until after the vehicle is started approximately 50 times. Stored faults are **not** erased if the battery is disconnected.



**Fig. 2 Controller Antilock Brakes**

**HYDRAULIC CONTROL UNIT**

The HCU consists of a valve body, pump body, accumulators, pump motor, and wire harnesses (Fig. 2).

The pump, motor, and accumulators are combined into an assembly attached to the valve body. The accumulators store the extra fluid released to the system for ABS mode operation. The pump provides the fluid volume needed and is operated by a DC type motor. The motor is controlled by the CAB.

The valve body contains the solenoid valves. The valves modulate brake pressure during antilock braking and are controlled by the CAB.

The HCU provides three channel pressure control to the front and rear brakes. One channel controls the rear wheel brakes in tandem. The two remaining channels control the front wheel brakes individually.

During antilock braking, the solenoid valves are opened and closed as needed. The valves are not static. They are cycled rapidly and continuously to modulate pressure and control wheel slip and deceleration.

During normal braking, the HCU solenoid valves and pump are not activated. The master cylinder and power booster operate the same as a vehicle without an ABS brake system.

During antilock braking, solenoid valve pressure modulation occurs in three stages, pressure increase, pressure hold, and pressure decrease. The valves are all contained in the valve body portion of the HCU.

**Pressure Decrease**

The outlet valve is opened and the inlet valve is closed during the pressure decrease cycle.

## DESCRIPTION AND OPERATION (Continued)

A pressure decrease cycle is initiated when speed sensor signals indicate high wheel slip at one or more wheels. At this point, the CAB closes the inlet then opens the outlet valve, which also opens the return circuit to the accumulators. Fluid pressure is allowed to bleed off (decrease) as needed to prevent wheel lock.

Once the period of high wheel slip has ended, the CAB closes the outlet valve and begins a pressure increase or hold cycle as needed.

**Pressure Hold**

Both solenoid valves are closed in the pressure hold cycle. Fluid apply pressure in the control channel is maintained at a constant rate. The CAB maintains the hold cycle until sensor inputs indicate a pressure change is necessary.

**Pressure Increase**

The inlet valve is open and the outlet valve is closed during the pressure increase cycle. The pressure increase cycle is used to counteract unequal wheel speeds. This cycle controls re-application of fluid apply pressure due to changing road surfaces or wheel speed.

**WHEEL SPEED SENSORS AND TONE WHEEL**

A speed sensor is used at each wheel. The front sensors are mounted to the steering knuckles. The rear sensors at the outboard end of the axle.

The sensors convert wheel speed into a small AC electrical signal. This signal is transmitted to the CAB. The CAB converts the AC signal into a digital signal for each wheel. This voltage is generated by magnetic induction when a tone wheel passes by the stationary magnet of the wheel speed sensor.

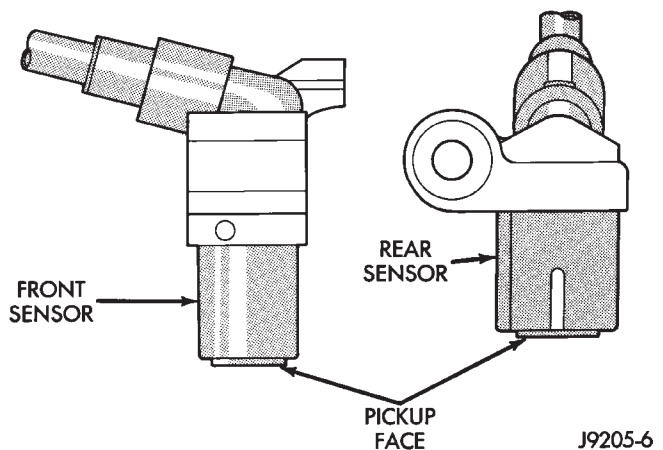
A gear type tone ring serves as the trigger mechanism for each sensor. The tone rings are mounted at the outboard ends of the front and rear axle shafts.

Different sensors are used at the front and rear wheels (Fig. 3). The front/rear sensors have the same electrical values but are not interchangeable. The sensors have a resistance between 900 and 1300 ohms.

**SPEED SENSOR AIR GAP****Front Sensor**

Front sensor air gap is fixed and not adjustable. Only rear sensor air gap is adjustable.

Although front air gap is not adjustable, it can be checked if diagnosis indicates this is necessary. Front air gap should be 0.36 to 1.5 mm (0.014 to 0.059 in.). If gap is incorrect, the sensor is either loose, or damaged.



**Fig. 3 Wheel Speed Sensors**

**Rear Sensor**

A rear sensor air gap adjustment is only needed when reinstalling an original sensor. Replacement sensors have an air gap spacer attached to the sensor pickup face. The spacer establishes correct air gap when pressed against the tone ring during installation. As the tone ring rotates, it peels the spacer off the sensor to create the required air gap. Rear sensor air gap is 0.92-1.275 mm (0.036-0.05 in.).

Sensor air gap measurement, or adjustment procedures are provided in this section. Refer to the front, or rear sensor removal and installation procedures as required.

**COMBINATION VALVE**

The combination valve contains a pressure differential valve and switch and a rear brake proportioning valve. The valve is not repairable and must be replaced as an assembly if diagnosis indicates this is necessary.

**PRESSURE DIFFERENTIAL VALVE**

The pressure differential switch is connected to the brake warning light. The switch is actuated by movement of the switch valve. The switch monitors fluid pressure in the separate front/rear brake hydraulic circuits.

A decrease or loss of fluid pressure in either hydraulic circuit will cause the switch valve to shuttle to the low pressure side. Movement of the valve pushes the switch plunger upward. This action closes the switch internal contacts completing the electrical circuit to the red warning light. The switch valve will remain in an actuated position until repairs to the brake system are made.

**PROPORTIONING VALVE**

The proportioning valve is used to balance front-rear brake action at high decelerations. The valve

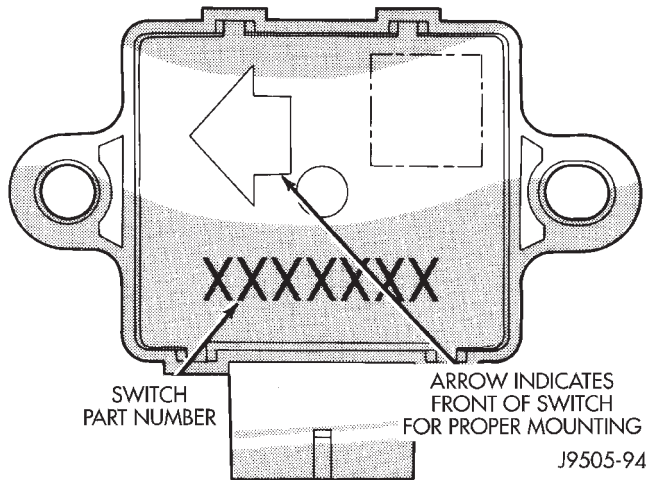


## DESCRIPTION AND OPERATION (Continued)

allows normal fluid flow during moderate braking. The valve only controls fluid flow during high decelerations brake stops.

**ACCELERATION SWITCH**

The acceleration switch is located under the rear seat. The switch (Fig. 4), provides an additional vehicle deceleration reference during 4WD operation. The switch is monitored by the CAB at all times. The switch reference signal is utilized by the CAB when all wheels are decelerating at the same speed.



**Fig. 4 Acceleration Switch**

**ABS WARNING LAMP**

The amber ABS warning lamp is located in the instrument cluster. The lamp illuminates at start-up to perform a self check. The lamp goes out when the self check program determines the system is operating normal. If an ABS component exhibits a fault the CAB will illuminate the lamp and register a trouble code in the microprocessor.

The lamp is controlled by the CAB. The lamp is illuminated when the CAB sends a ground signal to the ABS relay. The ABS relay then grounds the lamp circuit and illuminates the lamp.

**DIAGNOSIS AND TESTING****ANTILOCK BRAKES**

The ABS brake system performs several self-tests every time the ignition switch is turned on and the vehicle is driven. The CAB monitors the systems input and output circuits to verify the system is operating correctly. If the on board diagnostic system senses that a circuit is malfunctioning the system will set a trouble code in its memory.

**NOTE:** An audible noise may be heard during the self-test. This noise should be considered normal.

**NOTE:** The MDS or DRB III scan tool is used to diagnose the ABS system. For additional information refer to the Antilock Brake section in Group 8W. For test procedures refer to the Chassis Diagnostic Manual.

**SERVICE PROCEDURES****BLEEDING ABS BRAKE SYSTEM**

ABS system bleeding requires conventional bleeding methods plus use of the DRB scan tool. The procedure involves performing a base brake bleeding, followed by use of the scan tool to cycle and bleed the HCU pump and solenoids. A second base brake bleeding procedure is then required to remove any air remaining in the system.

- (1) Perform base brake bleeding. Refer to base brake section for procedure.
- (2) Connect scan tool to the Data Link Connector.
- (3) Select ANTILOCK BRAKES, followed by MISCELLANEOUS, then ABS BRAKES. Follow the instructions displayed. When scan tool displays TEST COMPLETE, disconnect scan tool and proceed.
- (4) Perform base brake bleeding a second time. Refer to base brake section for procedure.
- (5) Top off master cylinder fluid level and verify proper brake operation before moving vehicle.

**REMOVAL AND INSTALLATION****HYDRAULIC CONTROL UNIT/CONTROLLER ANTILOCK BRAKES****REMOVAL**

- (1) Remove negative battery cable from the battery.
- (2) Pull up on the CAB harness connector release (Fig. 5) and remove connector.
- (3) Remove brake lines from the HCU.
- (4) Remove HCU/CAB mounting nuts and bolt (Fig. 6) and remove HCU/CAB.

**INSTALLATION**

- (1) Install HCU/CAB on the mounting studs.
- (2) Install mounting nuts and bolt. Tighten to 11.5 N·m (102 in. lbs.).
- (3) Install brake lines to the HCU and tighten to 19 N·m (170 in. lbs.).
- (4) Install wiring harness connector to the CAB and push down on the release to secure the connector.
- (5) Install negative battery cable to the battery.
- (6) Bleed ABS brake system.

## REMOVAL AND INSTALLATION (Continued)

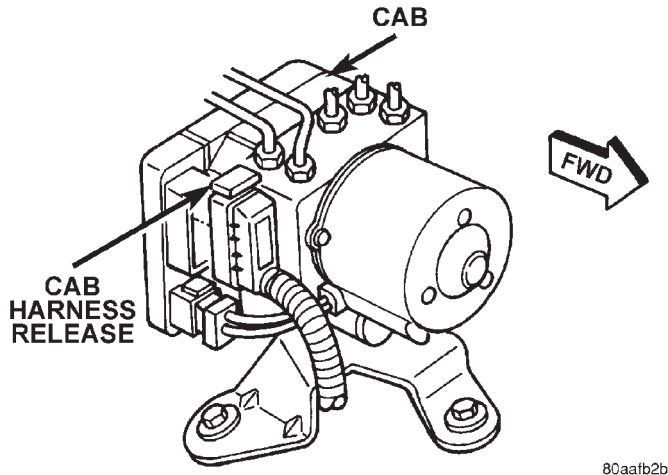


Fig. 5 CAB Harness Connector Release

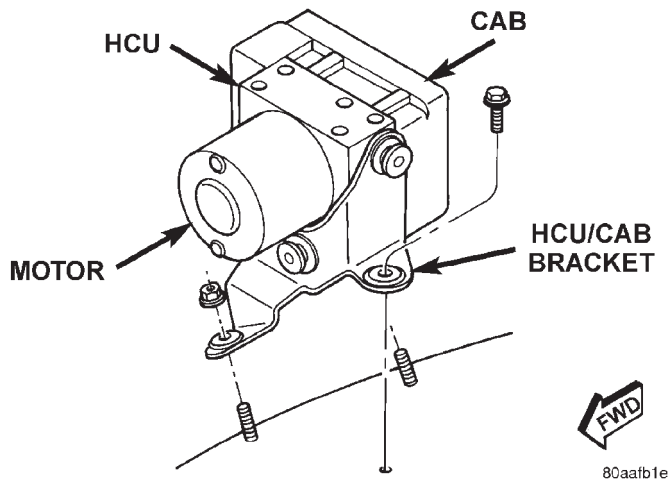


Fig. 6 HCU/CAB Mounting

## FRONT WHEEL SPEED SENSOR

## REMOVAL

- (1) Raise vehicle and turn wheel outward for easier access to sensor.
- (2) Remove sensor wire from mounting brackets.
- (3) Clean sensor and surrounding area with shop towel before removal.
- (4) Remove bolt attaching sensor to steering knuckle and remove sensor (Fig. 7).
- (5) Remove sensor wire from brackets on body and steering knuckle.
- (6) Unseat sensor wire grommet in wheel house panel.
- (7) In engine compartment, disconnect sensor wire connector at harness plug. Then remove sensor and wire.

## INSTALLATION

- (1) If **original** sensor will be installed, wipe all traces of old spacer material off sensor pickup face. Use a dry shop towel for this purpose.

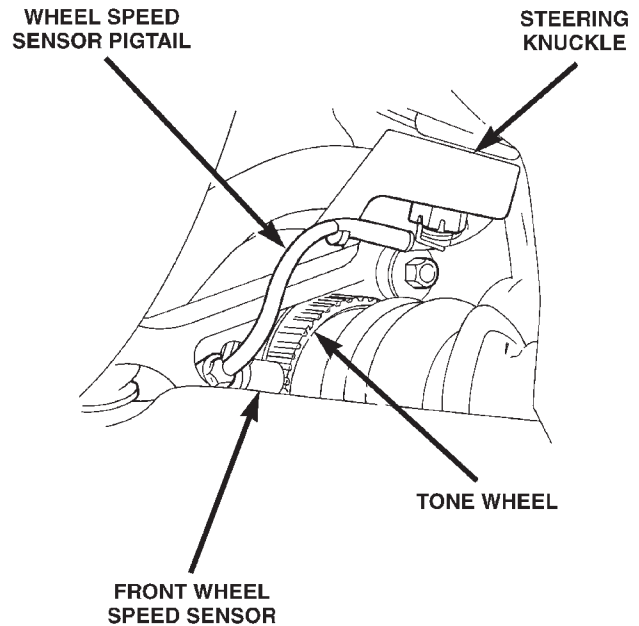


Fig. 7 Front Wheel Speed Sensor

- (2) Apply Mopar Lock N' Seal or Loctite<sup>®</sup> 242 to bolt that secures sensor in steering knuckle. Use new sensor bolt if original bolt is worn or damaged.

- (3) Position sensor on steering knuckle. Seat sensor locating tab in hole in knuckle and install sensor attaching bolt finger tight.

- (4) Tighten sensor attaching bolt to 4.7 N·m (42 in. lbs.).

- (5) If original sensor has been installed, check sensor air gap. Air gap should be 0.36 to 1.5 mm (0.014 to 0.059 in.). If gap is incorrect, sensor is either loose, or damaged.

- (6) Secure sensor wire to steering knuckle and body brackets.

- (7) Route sensor wire forward and behind shock absorber. Then attach sensor wire to spring seat bracket with grommets on sensor wire.

- (8) Route sensor wire to outer sill bracket. Remove all twists or kinks from wire.

- (9) Attach sensor wire to sill bracket with grommet. Be sure wire is free of twists and kinks.

- (10) Verify sensor wire routing. Wire should loop forward and above sill bracket. Loose end of wire should be below sill bracket and towards brake hose.

- (11) Seat sensor wire grommet in body panel and clip wire to brake line at grommet location.

- (12) Connect sensor wire to harness in engine compartment.

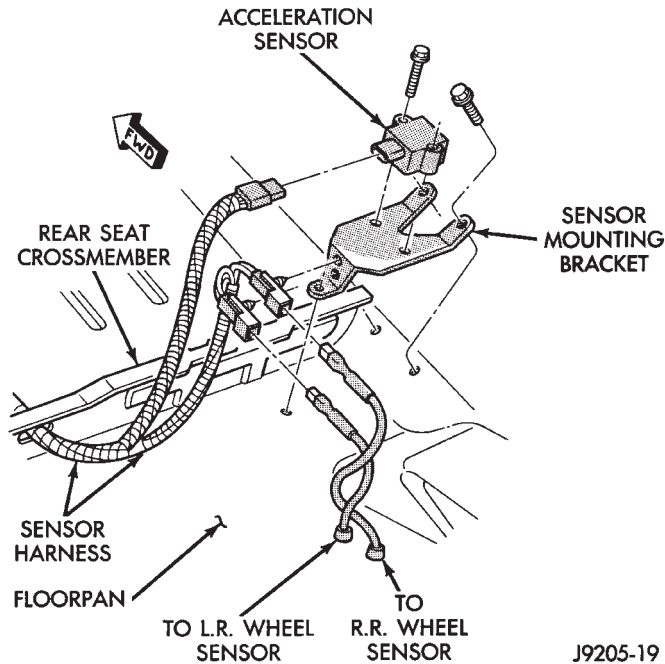
## REAR WHEEL SPEED SENSOR

## REMOVAL

- (1) Raise and fold rear seat forward for access to rear sensor connectors (Fig. 8).

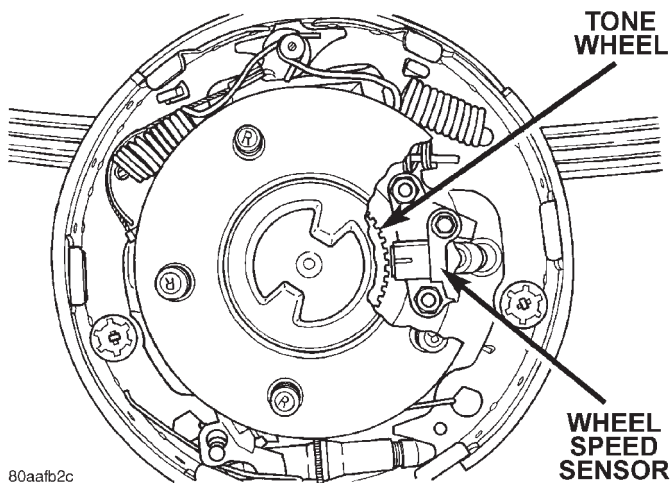
## REMOVAL AND INSTALLATION (Continued)

- (2) Disconnect sensors at rear harness connectors.
- (3) Push sensor grommets and sensor wires through floorpan.



**Fig. 8 Acceleration Switch And Rear Sensor Connections**

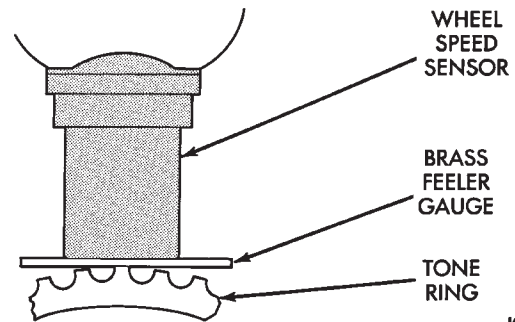
- (4) Raise vehicle.
- (5) Disconnect sensor wires at rear axle connectors.
- (6) Remove wheel and tire assembly.
- (7) Remove brake drum.
- (8) Remove clips securing sensor wires to brake lines, rear axle and, brake hose.
- (9) Unseat sensor wire support plate grommet.
- (10) Remove bolt attaching sensor to bracket and remove sensor (Fig. 9).



**Fig. 9 Rear Wheel Speed Sensor**

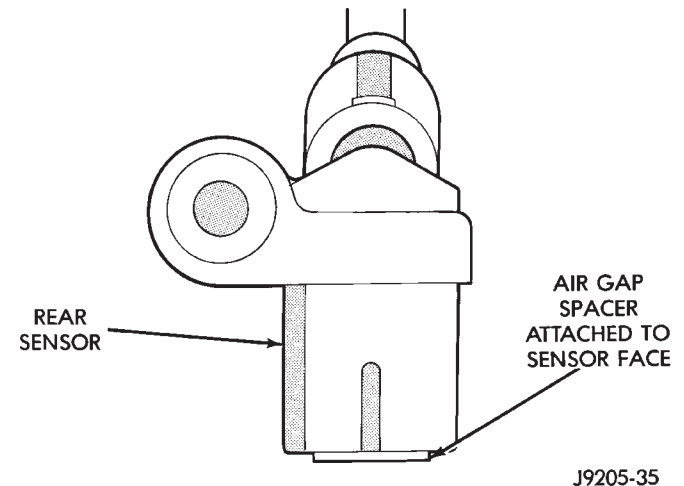
## INSTALLATION

- (1) If **original sensor** is being installed, remove any remaining pieces of cardboard spacer from sensor pickup face. Use dry shop towel only to remove old spacer material.
- (2) Insert sensor wire through support plate hole. Then seat sensor grommet in support plate.
- (3) Apply Mopar Lock N' Seal or Loctite® 242 to original sensor bolt. Use new bolt if original is worn or damaged.
- (4) Install sensor bolt finger tight only at this time.
- (5) If **original** rear sensor was installed, adjust sensor air gap to 0.92-1.275 mm (0.036-0.05 in.). Use feeler gauge to measure air gap (Fig. 10). Tighten sensor bolt to 13 N·m (115 in. lbs.).



**Fig. 10 Setting Air Gap On Original Rear Sensor**

- (6) If **new sensor** was installed, push cardboard spacer on sensor face against tone ring (Fig. 11). Then tighten sensor bolt to 13 N·m (115 in. lbs.). Correct air gap will be established as tone ring rotates and peels spacer off sensor face.



**Fig. 11 New Rear Sensor**

- (7) Route sensor wires to rear seat area.
- (8) Feed sensor wires through floorpan access hole and seat sensor grommets in floorpan.
- (9) Verify that rear sensor wires are secured to rear brake hose and axle with clips. Verify that wire is clear of rotating components.

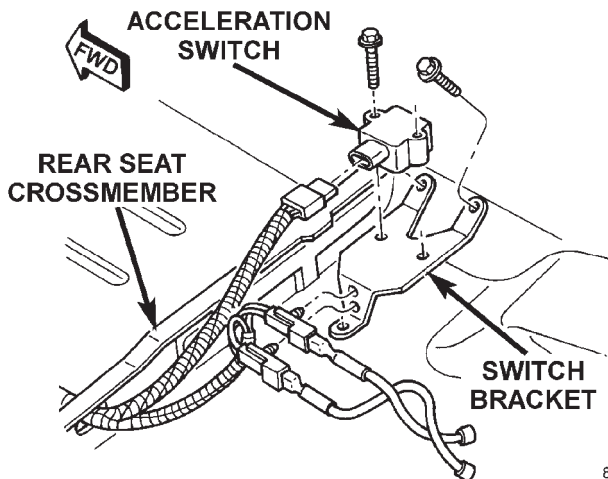
## REMOVAL AND INSTALLATION (Continued)

- (10) Install brake drum and wheel and tire assembly.
  - (11) Lower vehicle.
  - (12) Connect sensor wire to harness connector.
- Then reposition carpet and fold rear seat down.

## ACCELERATION SWITCH

## REMOVAL

- (1) Raise and fold rear seat assembly forward for access to sensor.
- (2) Disconnect switch harness.
- (3) Remove switch mounting screws (Fig. 12)
- (4) Remove the acceleration switch.



80aa1b1b

Fig. 12 Acceleration Switch Mounting

## INSTALLATION

**CAUTION:** The mercury switch (inside the acceleration switch), will not function properly if the switch is installed incorrectly. Verify that the switch locating arrow is pointing to the front of the vehicle (Fig. 13).

- (1) Position switch in mounting bracket.
- (2) Install switch mounting bolts and tighten to 3 N·m (27.5 in. lbs.).
- (3) Connect harness to switch. Be sure harness connector is firmly seated.
- (4) Move seat back to normal position.

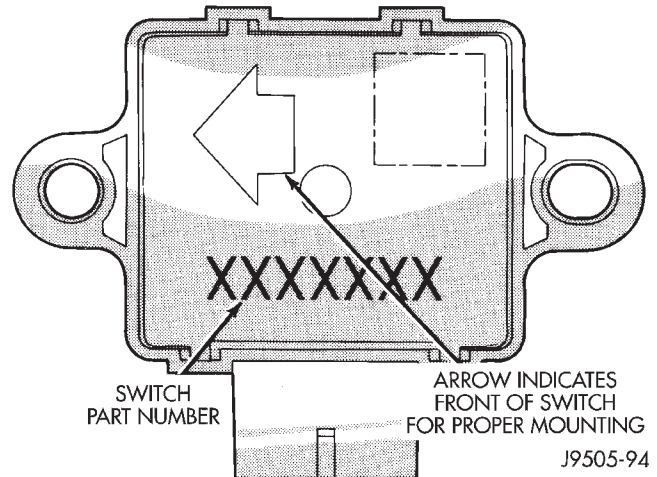


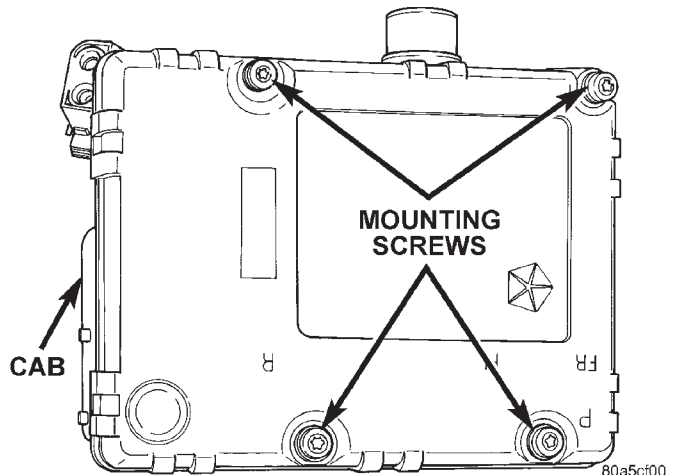
Fig. 13 Acceleration Switch

## DISASSEMBLY AND ASSEMBLY

HYDRAULIC CONTROL UNIT/CONTROLLER  
ANTILOCK BRAKE

## DISASSEMBLY

- (1) Remove pump motor connector from the CAB.
- (2) Remove CAB mounting screws from the HCU (Fig. 14).
- (3) Remove CAB from the HCU.



80a5c100

Fig. 14 CAB Mounting Screws

## ASSEMBLY

- (1) Install the CAB onto the HCU.
- (2) Install the CAB mounting screws and tighten to 1.8 N·m (16 in. lbs.).
- (3) Install pump motor connector to the CAB.

SPECIFICATIONS

TORQUE CHART

<b>DESCRIPTION</b>	<b>TORQUE</b>
<b>Acceleration Sensor</b>	
Sensor Bolt . . . . .	3 N·m (27.5 in. lbs.)
Bracket Bolt . . . . .	2.7 N·m (24 in. lbs.)
<b>Hydraulic Control Unit/Controller Antilock Brakes</b>	
Mounting Nuts . . . . .	11.5 N·m (102 in. lbs.)
Brake Lines . . . . .	19 N·m (170 in. lbs.)
<b>Controller Antilock Brakes</b>	
Mounting Screws . . . . .	1.8 N·m (16 in. lbs.)
<b>Wheel Speed Sensors</b>	
Front Mounting Bolt . . . . .	4.7 N·m (42 in. lbs.)
Rear Mounting Bolt . . . . .	13 N·m (115 in. lbs.)

