

# CHARGING SYSTEM

## CONTENTS

	page		page
<b>DESCRIPTION AND OPERATION</b>		<b>ON-BOARD DIAGNOSTIC TEST FOR</b>	
BATTERY TEMPERATURE SENSOR .....	2	CHARGING SYSTEM .....	3
CHARGING SYSTEM .....	1	<b>REMOVAL AND INSTALLATION</b>	
ELECTRONIC VOLTAGE REGULATOR .....	2	BATTERY TEMPERATURE SENSOR .....	4
GENERATOR .....	1	GENERATOR .....	3
<b>DIAGNOSIS AND TESTING</b>		<b>SPECIFICATIONS</b>	
BATTERY TEMPERATURE SENSOR .....	3	GENERATOR RATINGS .....	5
CHARGING SYSTEM .....	2	TORQUE CHART .....	5

## DESCRIPTION AND OPERATION

### CHARGING SYSTEM

#### DESCRIPTION

The charging system consists of:

- Generator
- Electronic Voltage Regulator (EVR) circuitry within the Powertrain Control Module (PCM)
- Ignition switch (refer to Group 8D, Ignition System for information)
- Battery (refer to Group 8A, Battery for information)
- Battery temperature sensor
- Generator Lamp (if equipped)
- Check Gauges Lamp (if equipped)
- Voltmeter (refer to Group 8E, Instrument Panel and Gauges for information)
- Wiring harness and connections (refer to Group 8W, Wiring for information)

#### OPERATION

The charging system is turned on and off with the ignition switch. The system is on when the engine is running and the ASD relay is energized. When the ASD relay is on, voltage is supplied to the ASD relay sense circuit at the PCM. This voltage is connected through the PCM and supplied to one of the generator field terminals (Gen. Source +) at the back of the generator.

The amount of DC current produced by the generator is controlled by the EVR (field control) circuitry contained within the PCM. This circuitry is connected in series with the second rotor field terminal and ground.

A battery temperature sensor, located in the battery tray housing, is used to sense battery temperature. This temperature data, along with data from

monitored line voltage, is used by the PCM to vary the battery charging rate. This is done by cycling the ground path to control the strength of the rotor magnetic field. The PCM then compensates and regulates generator current output accordingly.

All vehicles are equipped with On-Board Diagnostics (OBD). All OBD-sensed systems, including EVR (field control) circuitry, are monitored by the PCM. Each monitored circuit is assigned a Diagnostic Trouble Code (DTC). The PCM will store a DTC in electronic memory for certain failures it detects. Refer to On-Board Diagnostics in Group 25, Emission Control System for more DTC information.

The Check Gauges Lamp (if equipped) monitors: **charging system voltage**, engine coolant temperature and engine oil pressure. If an extreme condition is indicated, the lamp will be illuminated. This is done as reminder to check the three gauges. The signal to activate the lamp is sent via the CCD bus circuits. The lamp is located on the instrument panel. Refer to Group 8E, Instrument Panel and Gauges for additional information.

### GENERATOR

#### DESCRIPTION

The generator is belt-driven by the engine using a serpentine type drive belt. It is serviced only as a complete assembly. If the generator fails for any reason, the entire assembly must be replaced.

#### OPERATION

As the energized rotor begins to rotate within the generator, the spinning magnetic field induces a current into the windings of the stator coil. Once the generator begins producing sufficient current, it also provides the current needed to energize the rotor.

## DESCRIPTION AND OPERATION (Continued)

The Y type stator winding connections deliver the induced AC current to 3 positive and 3 negative diodes for rectification. From the diodes, rectified DC current is delivered to the vehicle electrical system through the generator battery terminal.

Although the generators appear the same externally, different generators with different output ratings are used on this vehicle. Be certain that the replacement generator has the same output rating and part number as the original unit. Refer to Generator Ratings in the Specifications section at the back of this group for amperage ratings and part numbers.

Noise emitting from the generator may be caused by: worn, loose or defective bearings; a loose or defective drive pulley; incorrect, worn, damaged or misadjusted fan drive belt; loose mounting bolts; a misaligned drive pulley or a defective stator or diode.

## BATTERY TEMPERATURE SENSOR

### DESCRIPTION

The battery temperature sensor is attached to the battery tray located under the battery.

### OPERATION

The battery temperature sensor is used to determine the battery temperature and control battery charging rate. This temperature data, along with data from monitored line voltage, is used by the PCM to vary the battery charging rate. System voltage will be higher at colder temperatures and is gradually reduced at warmer temperatures.

## ELECTRONIC VOLTAGE REGULATOR

### DESCRIPTION

The Electronic Voltage Regulator (EVR) is not a separate component. It is actually a voltage regulating circuit located within the Powertrain Control Module (PCM). The EVR is not serviced separately. If replacement is necessary, the PCM must be replaced.

### OPERATION

The amount of DC current produced by the generator is controlled by EVR circuitry contained within the PCM. This circuitry is connected in series with the generator's second rotor field terminal and its ground.

Voltage is regulated by cycling the ground path to control the strength of the rotor magnetic field. The EVR circuitry monitors system line voltage and battery temperature (refer to Battery Temperature Sensor for more information). It then compensates and regulates generator current output accordingly. Also

refer to Charging System Operation for additional information.

## DIAGNOSIS AND TESTING

### CHARGING SYSTEM

The following procedures may be used to diagnose the charging system if:

- the generator lamp (if equipped) is illuminated with the engine running
- the voltmeter (if equipped) does not register properly
- an undercharged or overcharged battery condition occurs.

Remember that an undercharged battery is often caused by:

- accessories being left on with the engine not running
- a faulty or improperly adjusted switch that allows a lamp to stay on. See Ignition-Off Draw Test in Group 8A, Battery for more information.

### INSPECTION

To perform a complete test of the charging system, refer to the appropriate Powertrain Diagnostic Procedures service manual and the DRB scan tool. Perform the following inspections before attaching the scan tool.

(1) Inspect the battery condition. Refer to Group 8A, Battery for procedures.

(2) Inspect condition of battery cable terminals, battery posts, connections at engine block, starter solenoid and relay. They should be clean and tight. Repair as required.

(3) Inspect all fuses in both the fuseblock and Power Distribution Center (PDC) for tightness in receptacles. They should be properly installed and tight. Repair or replace as required.

(4) Inspect generator mounting bolts for tightness. Replace or tighten bolts if required. Refer to the Generator Removal/Installation section of this group for torque specifications.

(5) Inspect generator drive belt condition and tension. Tighten or replace belt as required. Refer to Belt Tension Specifications in Group 7, Cooling System.

(6) Inspect automatic belt tensioner (if equipped). Refer to Group 7, Cooling System for information.

(7) Inspect generator electrical connections at generator field, battery output, and ground terminal (if equipped). Also check generator ground wire connection at engine (if equipped). They should all be clean and tight. Repair as required.

## DIAGNOSIS AND TESTING (Continued)

**BATTERY TEMPERATURE SENSOR**

To perform a complete test of this sensor and its circuitry, refer to the appropriate Powertrain Diagnostic Procedures manual. To test the sensor only, refer to the following:

(1) The sensor is located under the battery and is attached to the battery tray (Fig. 1). A two-wire pigtail harness is attached directly to the sensor. The opposite end of this harness connects the sensor to the engine wiring harness.

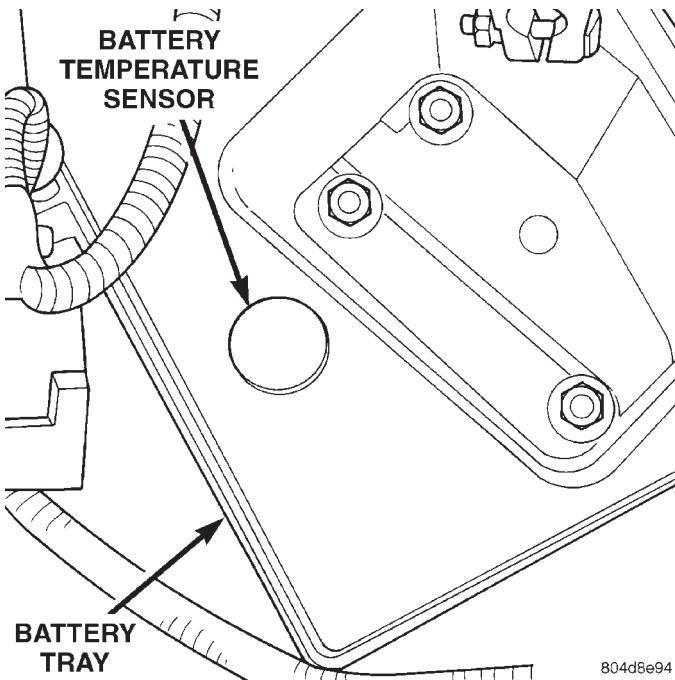

**Fig. 1 Battery Temperature Sensor**

(2) Disconnect the two-wire pigtail harness from the engine harness.

(3) Attach ohmmeter leads to the wire terminals of the pigtail harness.

(4) At room temperature of 25° C (75–80° F), an ohmmeter reading of 9,000 (9K) to 11,000 (11K) ohms should be observed.

(5) If reading is above or below the specification, replace the sensor.

(6) Refer to the Removal and Installation section for procedures.

**ON-BOARD DIAGNOSTIC TEST FOR CHARGING SYSTEM**

The Powertrain Control Module (PCM) monitors critical input and output circuits of the charging system, making sure they are operational. A Diagnostic Trouble Code (DTC) is assigned to each input and output circuit monitored by the On-Board Diagnostic (OBD) system. Some circuits are checked continuously and some are checked only under certain conditions.

For DTC information, refer to Diagnostic Trouble Codes in Group 25, Emission Control System. This will include a complete list of DTC's including DTC's for the charging system.

**REMOVAL AND INSTALLATION****GENERATOR****REMOVAL**

**WARNING: DISCONNECT NEGATIVE CABLE FROM BATTERY BEFORE REMOVING BATTERY OUTPUT WIRE (B+ WIRE) FROM GENERATOR. FAILURE TO DO SO CAN RESULT IN INJURY OR DAMAGE TO ELECTRICAL SYSTEM.**

- (1) Disconnect negative battery cable at battery.
- (2) Remove generator drive belt. Refer to Group 7, Cooling System for procedures.
- (3) Left Hand Drive (LHD) Vehicles Only: Remove generator pivot and mounting bolts/nut (Fig. 2) or (Fig. 3). Position generator for access to wire connectors.
- (4) Right Hand Drive (RHD) Vehicles Only: Remove upper nut (generator adjustment nut) and both belt adjustment bolts (Fig. 4). Remove generator lower nut/bolt. Position generator for access to wire connectors.
- (5) If equipped, unsnap plastic cover from B+ terminal.
- (6) Remove B+ terminal mounting nut at rear of generator (Fig. 5). Disconnect terminal from generator.
- (7) Disconnect field wire connector at rear of generator by pushing on connector tab.
- (8) Remove generator from vehicle.

**INSTALLATION**

- (1) Position generator to engine and snap field wire connector into rear of generator.
- (2) Install B+ terminal to generator mounting stud. Tighten mounting nut to 8.5 N·m (75 in. lbs.) torque.
- (3) If equipped, snap plastic cover to B+ terminal.
- (4) LHD Vehicles: Install generator fasteners and tighten as follows:
  - Generator upper mounting bolt-55 N·m (41 ft. lbs.) torque.
  - Generator lower pivot bolt/nut-55 N·m (41 ft. lbs.) torque.

**CAUTION: Never force a belt over a pulley rim using a screwdriver. The synthetic fiber of the belt can be damaged.**

## REMOVAL AND INSTALLATION (Continued)

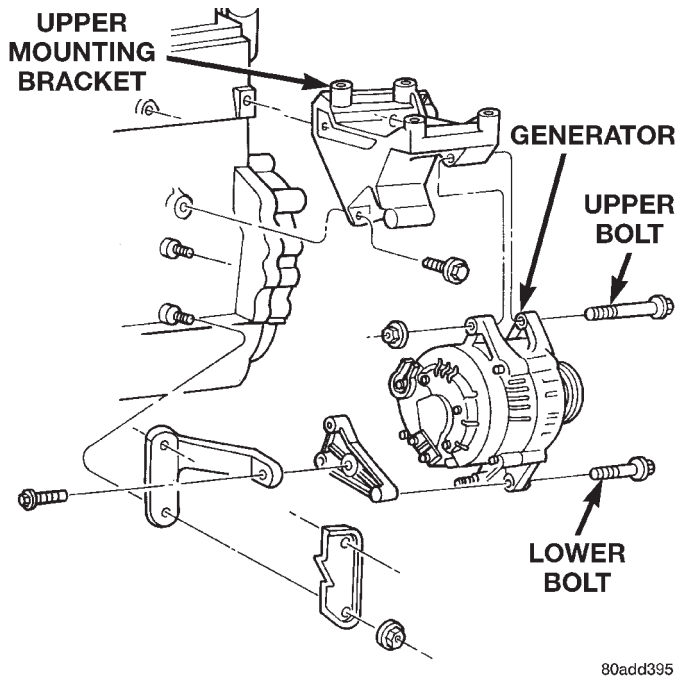

80add395

Fig. 2 Remove/Install Generator—2.5L Engine

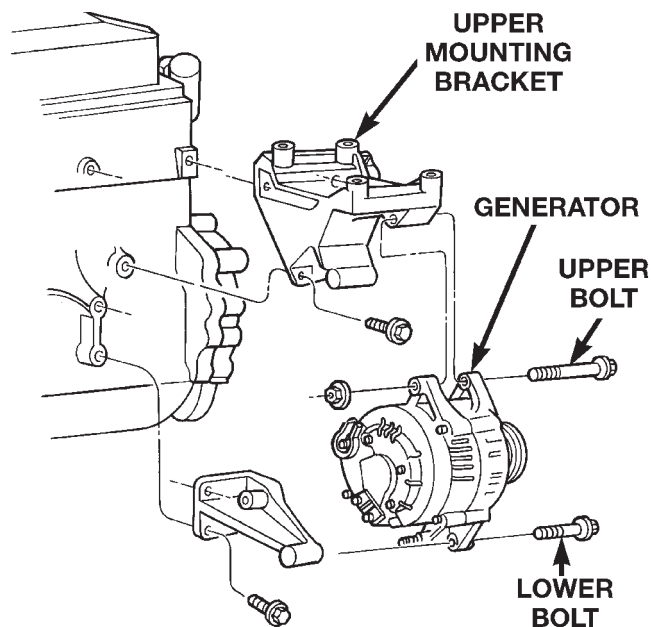

80add396

Fig. 3 Remove/Install Generator—4.0L Engine—LHD

**CAUTION:** When installing a serpentine accessory drive belt, the belt **MUST** be routed correctly. The water pump will be rotating in the wrong direction if the belt is installed incorrectly, causing the engine to overheat. Refer to belt routing label in engine compartment, or refer to Belt Schematics in Group 7, Cooling System.

(5) LHD Vehicles: Install generator drive belt. Refer to Group 7, Cooling System for procedures.

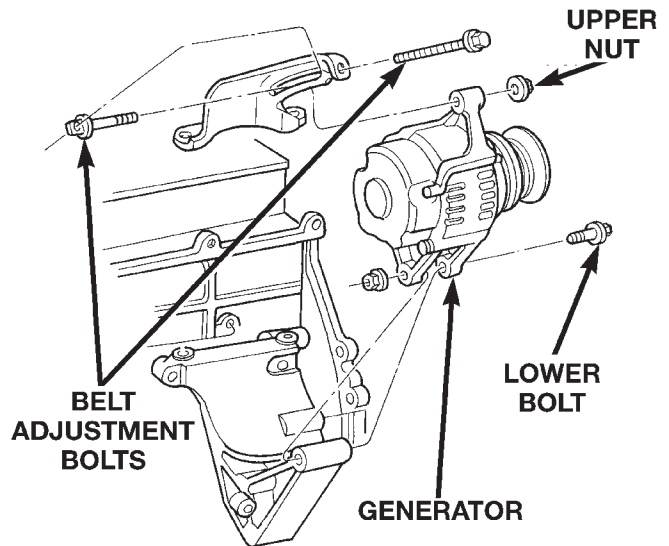

80a92a69

Fig. 4 Remove/Install Generator—4.0L Engine—RHD

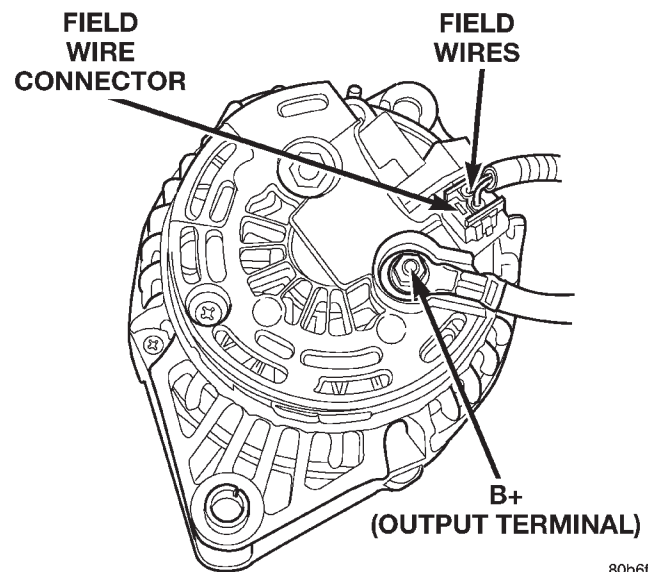

80b6f030

Fig. 5 Generator Connectors—Typical Bosch

(6) RHD Vehicles: Install upper nut (generator adjustment nut) and both belt adjustment bolts. Install generator lower nut/bolt.

(7) RHD Vehicles: On vehicles equipped with RHD, the generator is used to adjust the serpentine belt. Refer to Group 7, Cooling System for belt routing, belt adjustment and bolt tightening procedures.

(8) Install negative battery cable to battery.

**BATTERY TEMPERATURE SENSOR**

The battery temperature sensor is located under vehicle battery (Fig. 6) and is attached to a mounting hole on battery tray.

REMOVAL AND INSTALLATION (Continued)

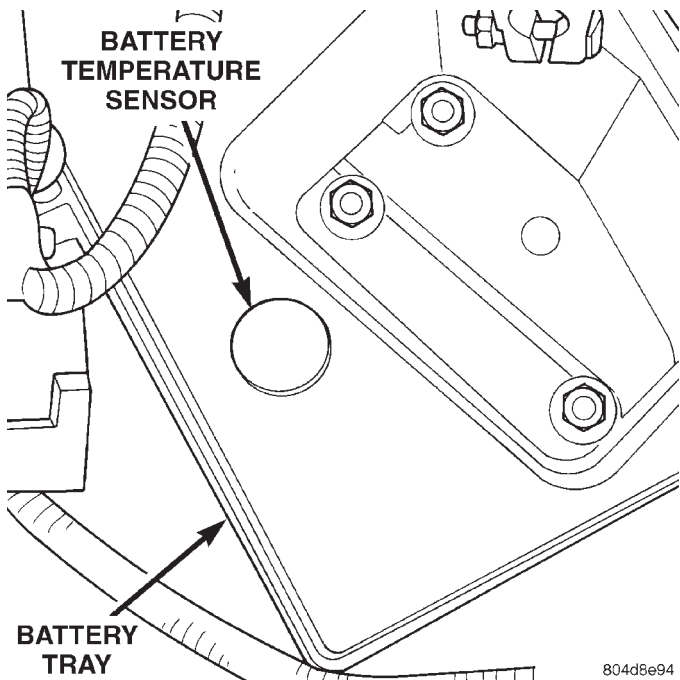

Fig. 6 Battery Temperature Sensor

- (2) Disconnect sensor pigtail harness from engine wire harness.
- (3) Pry sensor straight up from battery tray mounting hole.

**INSTALLATION**

- (1) Feed pigtail harness through hole in top of battery tray and press sensor into top of battery tray.
- (2) Connect pigtail harness.
- (3) Install battery. Refer to Group 8A, Battery for procedures.

**SPECIFICATIONS**

**REMOVAL**

- (1) Remove battery. Refer to Group 8A, Battery for procedures.

**GENERATOR RATINGS**

TYPE	PART NUMBER	RATED SAE AMPS	ENGINES	MINIMUM TEST AMPS
DENSO	56041822AA	124	2.5L/4.0L	90

**TORQUE CHART**

Right Hand Drive= RHD, Left Hand Drive= LHD.

Description	Torque
Generator Mounting Bolt—LHD— 2.5L/4.0L Engine . . . . .	55 N·m (41 ft. lbs.)
Generator Pivot Bolt/Nut—LHD— 2.5L/4.0L Engine . . . . .	55 N·m (41 ft. lbs.)
Battery Terminal Nut—LHD or RHD . . . . .	8.5 N·m (75 in. lbs.)

Description	Torque
Ground Terminal Nut—LHD or RHD . . . . .	8.5 N·m (75 in. lbs.)
Harness Hold-down Nut—LHD or RHD . . . . .	8.5 N·m (75 in. lbs.)
Field Terminal Nuts—LHD or RHD . . . . .	2.8 N·m (25 in. lbs.)

