

HORN SYSTEMS

CONTENTS

	page		page
DESCRIPTION AND OPERATION		HORN RELAY	3
HORN	1	HORN SWITCH	3
HORN RELAY	2	REMOVAL AND INSTALLATION	
HORN SWITCH	2	HORN	5
HORN SYSTEM	1	HORN RELAY	4
DIAGNOSIS AND TESTING			
HORN	4		

DESCRIPTION AND OPERATION

HORN SYSTEM

DESCRIPTION

A dual-note electric horn system is standard factory-installed equipment on this model. The standard equipment horn system features one low-note horn unit and one high-note horn unit. The horn system uses a non-switched source of battery current so that the system will remain functional, regardless of the ignition switch position. The horn system includes the following components:

- Clockspring
- Horns
- Horn relay
- Horn switch
- Remote Keyless Entry (RKE) receiver (only with the RKE system)

Refer to **Clockspring** in the Description and Operation section of Group 8M - Passive Restraint Systems for more information on this component. Refer to **Remote Keyless Entry System** in the Description and Operation section of Group 8P - Power Lock Systems for more information on this component. Refer to **Horn/Cigar Lighter** in the Contents of Group 8W - Wiring Diagrams for complete circuit diagrams. Following are general descriptions of the remaining major components in the horn system.

OPERATION

The horn system is activated by a horn switch concealed beneath the driver side airbag module trim cover in the center of the steering wheel. Depressing the center of the driver side airbag module trim cover closes the horn switch. Closing the horn switch activates the horn relay. The activated horn relay then switches the battery current needed to energize the horns.

Refer to the owner's manual in the vehicle glove box for more information on the features, use and operation of the horn system.

REMOTE KEYLESS ENTRY RECEIVER

The Remote Keyless Entry (RKE) receiver can also operate the horn system. An RKE receiver is used on this vehicle when it is equipped with the optional RKE system. The RKE receiver controls and integrates the additional electronic functions and features included on models with this option. A customer programmable feature of the RKE system enables the RKE receiver to momentarily energize the horn relay through a hard wired circuit as an audible verification that the receiver has received a valid lock request from the RKE transmitter.

Refer to **Remote Keyless Entry System** in the Description and Operation section of Group 8P - Power Lock Systems for more information on this feature.

HORN

DESCRIPTION

The dual electromagnetic diaphragm-type horns are standard equipment on this model. The low-note horn is secured with a bracket to the left radiator closure panel brace, behind the front bumper. The high-note horn is secured with a bracket to the right radiator closure panel brace, behind the front bumper. Both horns are grounded through their mounting brackets and receives battery feed through its wire harness connector and circuit from the closed contacts of the horn relay.

The horns cannot be repaired or adjusted and, if faulty or damaged, they must be individually replaced.

DESCRIPTION AND OPERATION (Continued)

OPERATION

Within the two halves of the molded plastic horn housing are a flexible diaphragm, a plunger, an electromagnetic coil and a set of contact points. The diaphragm is secured in suspension around its perimeter by the mating surfaces of the horn housing. The plunger is secured to the center of the diaphragm and extends into the center of the electromagnet. The contact points control the current flow through the electromagnet.

When the horn is energized, electrical current flows through the closed contact points to the electromagnet. The resulting electromagnetic field draws the plunger and diaphragm toward it until that movement mechanically opens the contact points. When the contact points open, the electromagnetic field collapses allowing the plunger and diaphragm to return to their relaxed positions and closing the contact points again. This cycle continues repeating at a very rapid rate producing the vibration and movement of air that creates the sound that is directed through the horn outlet.

HORN RELAY

DESCRIPTION

The horn relay is an electromechanical device that switches battery current to the horn when the horn switch grounds the relay coil. The horn relay is located in the junction block on the right cowl side inner panel below the instrument panel in the passenger compartment. If a problem is encountered with a continuously sounding horn, it can usually be quickly resolved by removing the horn relay from the junction block until further diagnosis is completed. Refer to **Junction Block** in the Contents of Group 8W - Wiring Diagrams for horn relay identification and location.

The horn relay is an International Standards Organization (ISO) relay. Relays conforming to the ISO specifications have common physical dimensions, current capacities, terminal patterns, and terminal functions.

The horn relay cannot be repaired or adjusted and, if faulty or damaged, it must be replaced.

OPERATION

The ISO relay consists of an electromagnetic coil, a resistor or diode, and three (two fixed and one movable) electrical contacts. The movable (common feed) relay contact is held against one of the fixed contacts (normally closed) by spring pressure. When the electromagnetic coil is energized, it draws the movable contact away from the normally closed fixed contact, and holds it against the other (normally open) fixed contact.

When the electromagnetic coil is de-energized, spring pressure returns the movable contact to the normally closed position. The resistor or diode is connected in parallel with the electromagnetic coil in the relay, and helps to dissipate voltage spikes that are produced when the coil is de-energized.

HORN SWITCH

DESCRIPTION

A center-blow, normally open, resistive membrane-type horn switch is secured with heat stakes to the back side of the driver side airbag module trim cover in the center of the steering wheel (Fig. 1). The switch consists of two plastic membranes, one that is flat and one that is slightly convex. These two membranes are secured to each other around the perimeter. Inside the switch, the centers of the facing surfaces of these membranes each has a grid made with an electrically conductive material applied to it. One of the grids is connected to a circuit that provides it with continuity to ground at all times. The grid of the other membrane is connected to the horn relay control circuit.

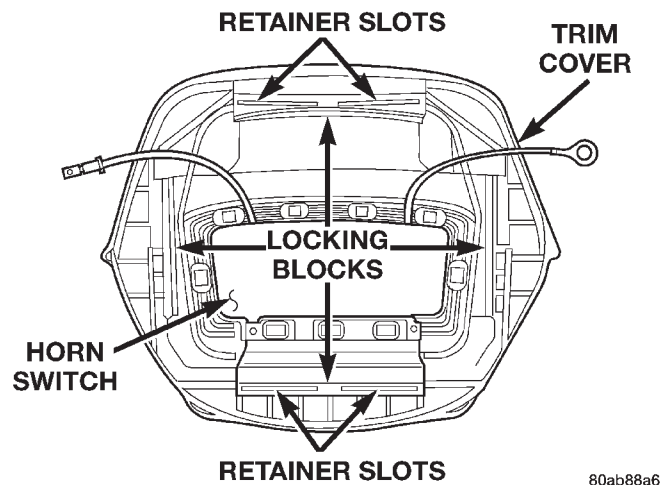

Fig. 1 Driver Side Airbag Module Trim Cover and Horn Switch

The steering wheel and steering column must be properly grounded in order for the horn switch to function properly. The horn switch is only serviced as a part of the driver side airbag module trim cover. If the horn switch is damaged or faulty, or if the driver side airbag is deployed, the driver side airbag module trim cover and horn switch must be replaced as a unit.

OPERATION

When the center area of the driver side airbag trim cover is depressed, the electrically conductive grids on the facing surfaces of the horn switch membranes contact each other, closing the switch circuit. The

DESCRIPTION AND OPERATION (Continued)

completed horn switch circuit provides a ground for the control coil side of the horn relay, which activates the relay. When the horn switch is released, the resistive tension of the convex membrane separates the two electrically conductive grids and opens the switch circuit.

DIAGNOSIS AND TESTING

HORN RELAY

The horn relay (Fig. 2) is located in the junction block on the right cowl side inner panel below the instrument panel in the passenger compartment. If a problem is encountered with a continuously sounding horn, it can usually be quickly resolved by removing the horn relay from the junction block until further diagnosis is completed. Refer to **Junction Block** in the Contents of Group 8W - Wiring Diagrams for horn relay identification and location. For complete circuit diagrams, refer to **Horn/Cigar Lighter** in the Contents of Group 8W - Wiring Diagrams.

WARNING: ON VEHICLES EQUIPPED WITH AIRBAGS, REFER TO GROUP 8M - PASSIVE RESTRAINT SYSTEMS BEFORE ATTEMPTING ANY STEERING WHEEL, STEERING COLUMN, OR INSTRUMENT PANEL COMPONENT DIAGNOSIS OR SERVICE. FAILURE TO TAKE THE PROPER PRECAUTIONS COULD RESULT IN ACCIDENTAL AIRBAG DEPLOYMENT AND POSSIBLE PERSONAL INJURY.

- (1) Remove the horn relay from the junction block. Refer to **Horn Relay** in the Removal and Installation section of this group for the procedures.
- (2) A relay in the de-energized position should have continuity between terminals 87A and 30, and no continuity between terminals 87 and 30. If OK, go to Step 3. If not OK, replace the faulty relay.
- (3) Resistance between terminals 85 and 86 (electromagnet) should be 75 ± 5 ohms. If OK, go to Step 4. If not OK, replace the faulty relay.
- (4) Connect a battery to terminals 85 and 86. There should now be continuity between terminals 30 and 87, and no continuity between terminals 87A and 30. If OK, perform the Relay Circuit Test that follows. If not OK, replace the faulty relay.

RELAY CIRCUIT TEST

- (1) The relay common feed terminal cavity (30) is connected to battery voltage and should be hot at all times. If OK, go to Step 2. If not OK, repair the open circuit to the fuse in the junction block as required.
- (2) The relay normally closed terminal (87A) is connected to terminal 30 in the de-energized position, but is not used for this application. Go to Step 3.

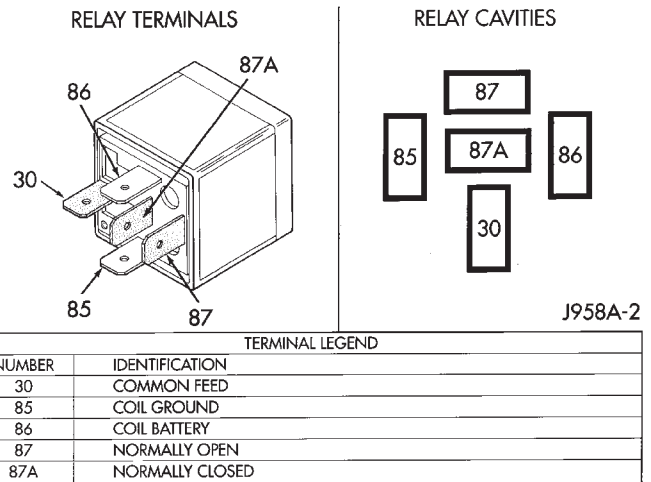

Fig. 2 Horn Relay

(3) The relay normally open terminal (87) is connected to the common feed terminal (30) in the energized position. This terminal supplies battery voltage to the horn(s). There should be continuity between the cavity for relay terminal 87 and the horn relay output circuit cavity of each horn wire harness connector at all times. If OK, go to Step 4. If not OK, repair the open circuit to the horn(s) as required.

(4) The coil battery terminal (86) is connected to the electromagnet in the relay. It is connected to battery voltage and should be hot at all times. Check for battery voltage at the cavity for relay terminal 86. If OK, go to Step 5. If not OK, repair the open circuit to the fuse in the junction block as required.

(5) The coil ground terminal (85) is connected to the electromagnet in the relay. It is grounded through the horn switch when the horn switch is depressed. On vehicles equipped with the Remote Keyless Entry (RKE) system, the horn relay coil ground terminal can also be grounded by the RKE receiver in response to certain inputs related to the RKE system. Check for continuity to ground at the cavity for relay terminal 85. There should be continuity with the horn switch depressed, and no continuity with the horn switch released. If not OK, refer to **Horn Switch** in the Diagnosis and Testing section of this group.

HORN SWITCH

For complete circuit diagrams, refer to **Horn/Cigar Lighter** in the Contents of Group 8W - Wiring Diagrams.

DIAGNOSIS AND TESTING (Continued)

WARNING: ON VEHICLES EQUIPPED WITH AIRBAGS, REFER TO GROUP 8M - PASSIVE RESTRAINT SYSTEMS BEFORE ATTEMPTING ANY STEERING WHEEL, STEERING COLUMN, OR INSTRUMENT PANEL COMPONENT DIAGNOSIS OR SERVICE. FAILURE TO TAKE THE PROPER PRECAUTIONS COULD RESULT IN ACCIDENTAL AIRBAG DEPLOYMENT AND POSSIBLE PERSONAL INJURY.

(1) Disconnect and isolate the battery negative cable. Remove the knee blocker from the instrument panel.

(2) Check for continuity between the metal steering column jacket and a good ground. There should be continuity. If OK, go to Step 3. If not OK, refer to **Steering Column** in the Removal and Installation section of Group 19 - Steering for proper installation of the steering column.

(3) Remove the driver side airbag module from the steering wheel. Disconnect the horn switch wire harness connectors from the driver side airbag module.

(4) Remove the horn relay from the junction block. Check for continuity between the steering column half of the horn switch feed wire harness connector and a good ground. There should be no continuity. If OK, go to Step 5. If not OK, repair the shorted horn relay control circuit to the horn relay in the junction block as required.

(5) Check for continuity between the steering column half of the horn switch feed wire harness connector and the horn relay control circuit cavity for the horn relay in the junction block. There should be continuity. If OK, go to Step 6. If not OK, repair the open horn relay control circuit to the horn relay in the junction block as required.

(6) Check for continuity between the horn switch feed wire and the horn switch ground wire on the driver side airbag module. There should be no continuity. If OK, go to Step 7. If not OK, replace the faulty horn switch.

(7) Depress the center of the driver side airbag module trim cover and check for continuity between the horn switch feed wire and the horn switch ground wire on the driver side airbag module. There should now be continuity. If not OK, replace the faulty horn switch.

HORN

For complete circuit descriptions, refer to **Horn/Cigar Lighter** in the Contents of Group 8W - Wiring Diagrams.

(1) Measure the resistance between the horn(s) mounting bracket(s) and a good ground. There should be no measurable resistance. If OK, go to Step 2. If

not OK, clean and tighten the horn mounting hardware as required.

(2) Disconnect the wire harness connector(s) from the horn connector receptacle(s). Check for battery voltage at the horn relay output circuit cavity of the horn(s) wire harness connector(s). There should be zero volts. If OK, go to Step 3. If not OK, repair the shorted horn relay output circuit or replace the faulty horn relay as required.

(3) Depress the horn switch. There should now be battery voltage at the horn relay output circuit cavity of the horn(s) wire harness connector(s). If OK, replace the faulty horn(s). If not OK, repair the open horn relay output circuit to the horn relay as required.

REMOVAL AND INSTALLATION

HORN RELAY

REMOVAL

(1) Disconnect and isolate the battery negative cable.

(2) Remove the fuse access panel by unsnapping it from the right cowl side inner trim panel (Fig. 3).

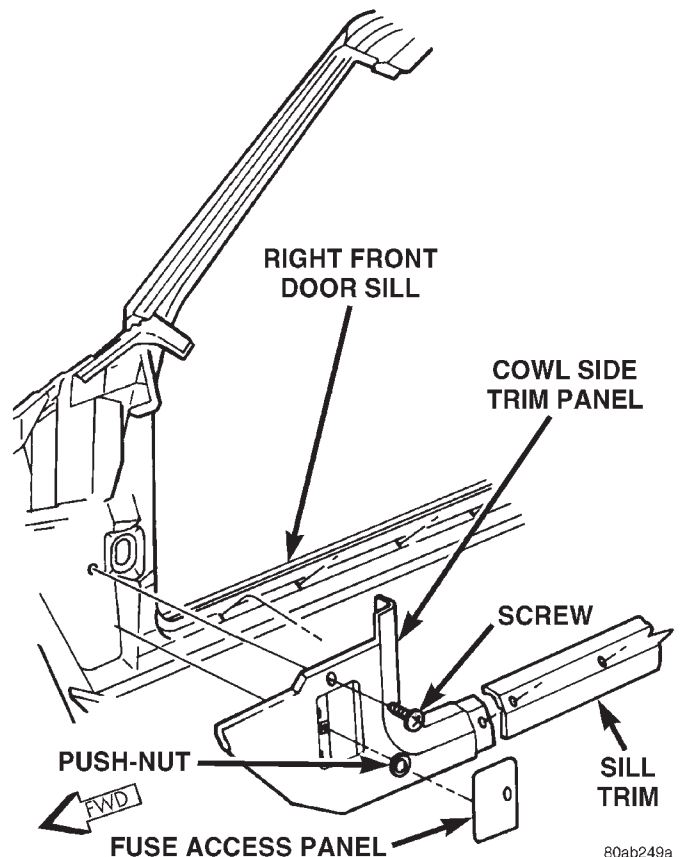

Fig. 3 Right Cowl Side Inner Trim Remove/Install

REMOVAL AND INSTALLATION (Continued)

(3) Remove the push nut that secures the right cowl side inner trim panel to the junction block stud.

(4) Remove the screw located above the fuse access opening that secures the trim panel to the right cowl side inner panel.

(5) Remove the screw that secures the right cowl side inner trim panel and right front door sill trim to the door opening sill.

(6) Remove the trim from the right cowl side inner panel.

(7) Refer to **Junction Block** in the Contents of Group 8W - Wiring Diagrams for horn relay identification and location.

(8) Remove the horn relay from the junction block.

INSTALLATION

(1) Refer to **Junction Block** in the Contents of Group 8W - Wiring Diagrams for proper horn relay location.

(2) Position the horn relay in the proper receptacle in the junction block.

(3) Align the horn relay terminals with the terminal cavities in the junction block receptacle.

(4) Push down firmly on the horn relay until the terminals are fully seated in the terminal cavities in the junction block receptacle.

(5) Position the trim onto the right cowl side inner panel.

(6) Install and tighten the screw that secures the right cowl side inner trim panel and right front door sill trim to the door opening sill. Tighten the screw to 2.2 N·m (20 in. lbs.).

(7) Install and tighten the screw located above the fuse access opening that secures the trim panel to the right cowl side inner panel. Tighten the screw to 2.2 N·m (20 in. lbs.).

(8) Install the push nut that secures the right cowl side inner trim panel onto the junction block stud.

(9) Install the fuse access panel by snapping it onto the right cowl side inner trim panel.

(10) Reconnect the battery negative cable.

HORN

REMOVAL

(1) Disconnect and isolate the battery negative cable.

(2) Raise and support the vehicle.

(3) Remove the front underbody splash shield.

NOTE: Remove the horn and its mounting bracket from the vehicle as a unit. Do not remove the horn from its mounting bracket.

(4) Remove the screw that secures the horn and mounting bracket unit to the radiator closure panel brace (Fig. 4).

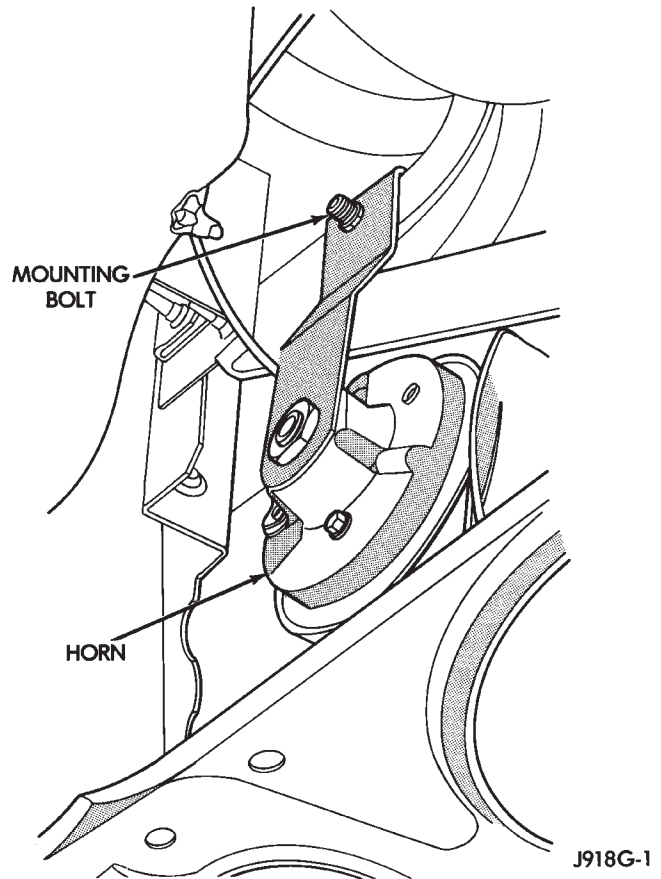

Fig. 4 Horns Remove/Install

(5) Lower the horn and mounting bracket unit far enough to access and disconnect the wire harness connector from the horn connector receptacle.

(6) Remove the horn and mounting bracket unit from behind the front bumper.

INSTALLATION

(1) Position the horn and mounting bracket unit behind the front bumper.

(2) Reconnect the wire harness connector to the horn connector receptacle.

(3) Position the horn and mounting bracket unit to the radiator closure panel brace.

(4) Install and tighten the screw that secures the horn and mounting bracket unit to the radiator closure panel brace. Tighten the screw to 28.5 N·m (21 ft. lbs.).

(5) Install the front underbody splash shield.

(6) Lower the vehicle.

(7) Reconnect the battery negative cable.

