

WIPER AND WASHER SYSTEMS

CONTENTS

	page		page
GENERAL INFORMATION		WIPER SWITCH AND WASHER SWITCH	3
INTRODUCTION	1	DIAGNOSIS AND TESTING	
REAR WIPER AND WASHER SYSTEM	2	WASHER SYSTEM	6
WINDSHIELD WASHER SYSTEM	1	WIPER SWITCH AND WASHER SWITCH	7
WINDSHIELD WIPER SYSTEM	1	WIPER SYSTEM	4
DESCRIPTION AND OPERATION		REMOVAL AND INSTALLATION	
WASHER FLUID LEVEL SENSOR	4	WASHER SYSTEM	12
WASHER NOZZLE AND PLUMBING	4	WIPER ARM	8
WASHER PUMP	4	WIPER BLADE	8
WASHER RESERVOIR	3	WIPER LINKAGE AND PIVOT	9
WIPER ARM AND BLADE	2	WIPER MOTOR	9
WIPER LINKAGE AND PIVOT	2	WIPER SWITCH AND WASHER SWITCH	10
WIPER MOTOR	2		

GENERAL INFORMATION

INTRODUCTION

Windshield wiper and washer systems are standard factory-installed equipment on this model. A rear wiper and washer system is optional factory-installed equipment. Following is general information about the available wiper and washer systems for this vehicle. Refer to 8W-53 - Wipers in Group 8W - Wiring Diagrams for complete circuit descriptions and diagrams.

NOTE: This group covers both Left-Hand Drive (LHD) and Right-Hand Drive (RHD) versions of this model. Whenever required and feasible, the RHD versions of affected vehicle components have been constructed as mirror-image of the LHD versions. While most of the illustrations used in this group represent only the LHD version, the diagnostic and service procedures outlined can generally be applied to either version. Exceptions to this rule have been clearly identified as LHD or RHD, if a special illustration or procedure is required.

WINDSHIELD WIPER SYSTEM

An intermittent windshield wiper system is standard equipment on this model. The intermittent wiper system lets the driver select from either of two wiper speeds, low or high, or the intermittent wipe delay mode.

The intermittent wipe mode delay times are driver adjustable from about one second to about fifteen seconds. The intermittent wipe mode is provided by delay logic and relay control circuitry contained within the intermittent wiper/washer switch. The intermittent wipe relay is also contained within the switch.

The windshield wipers will operate only when the ignition switch is in the Accessory or On positions. A circuit breaker located in the junction block protects the circuitry of the windshield wiper system. Refer to the owner's manual in the vehicle glove box for more information on the features, use and operation of the windshield wiper system.

WINDSHIELD WASHER SYSTEM

An electrically operated windshield washer system is standard equipment. The washer reservoir is located between the inner and outer front fenders, above and forward of the left front wheel housing. The reservoir filler neck is located in the engine compartment on the left inner fender shield.

The washer reservoir holds the washer fluid, which is pressurized by a pump when the windshield washer switch lever is actuated. The windshield washer pump feeds the pressurized washer fluid through the washer system plumbing to the windshield washer nozzles.

A low washer fluid warning lamp is standard equipment on all models equipped with the optional rear wiper and washer system. The low washer fluid warning lamp in the instrument cluster will warn

GENERAL INFORMATION (Continued)

the driver when the washer fluid level needs to be checked. Refer to Group 8E - Instrument Panel Systems for more information on this feature.

The washers will operate only when the ignition switch is in the Accessory or On positions. If the wipers are not already turned on when the washers are activated, the wipers will be automatically cycled for one or two wipes, then be turned off. A fuse located in the junction block protects the circuitry of the washer system. Refer to the owner's manual in the vehicle glove box for more information on the features, use and operation of the windshield washer system.

REAR WIPER AND WASHER SYSTEM

A rear wiper and washer system is an available option on this model. The rear wiper system is a fixed-cycle wiper system. A single switch in the instrument panel accessory switch bezel controls both the rear wiper and washer functions. The rear washer system shares the reservoir of the windshield washer system, but has its own dedicated washer pump and plumbing.

The rear wiper and washer systems will operate only when the ignition switch is in the Accessory or On positions. A fuse in the junction block protects the circuitry of both the rear wiper and washer systems.

Refer to the owner's manual in the vehicle glove box for more information on the features, use and operation of the rear wiper and washer system.

DESCRIPTION AND OPERATION

WIPER ARM AND BLADE

All Cherokee models have two 45.72-centimeter (18-inch) windshield wiper blades with non-replaceable rubber elements (squeegees). The optional rear wiper uses a single 33.0-centimeter (13-inch) wiper blade with a non-replaceable rubber element (squeegee).

Caution should be exercised to protect the rubber squeegees from any petroleum-based cleaners or contaminants, which will rapidly deteriorate the rubber. If the squeegees are damaged, worn, or contaminated, the entire wiper blade assembly must be replaced.

Wiper squeegees exposed to the elements for a long time tend to lose their wiping effectiveness. Periodic cleaning of the squeegees is suggested to remove deposits of salt and road film. The wiper blades, arms, and windshield or rear glass should be cleaned with a sponge or cloth and windshield washer fluid, a mild detergent, or a non-abrasive cleaner. If the squeegees continue to streak or smear, the wiper blades should be replaced.

The blades are mounted to spring-loaded wiper arms. The spring tension of the wiper arms controls the pressure applied to the blades on the glass. The windshield wiper arms are secured by an integral latch to the two wiper pivots on the cowl plenum cover/grille panel at the base of the windshield. The rear wiper arm is secured by a nut directly to the rear wiper motor output shaft on the liftgate below the liftgate glass.

The wiper arms and blades cannot be adjusted or repaired. If faulty or damaged, they must be replaced.

WIPER LINKAGE AND PIVOT

The wiper linkage and pivot module is secured with screws to the cowl top panel beneath the cowl plenum cover/grille panel. The wiper motor is secured with screws to the center of the linkage and pivot module bracket. The wiper pivots are secured to the ends of the module bracket.

The two wiper pivot crank arms and the wiper motor crank arm each have ball studs on their ends. The left pivot ball stud is the longer of the three. A connecting link with a plastic socket-type bushing in the right end, and a plastic sleeve-type bushing in the left end, is fit over the pivot ball studs to join the two pivots.

The wiper drive link has a plastic socket-type bushing on each end. One end of the drive link is snap-fit over the exposed end of the longer left pivot ball stud, while the other end is snap-fit over the ball stud on the wiper motor crank arm.

The wiper linkage, pivots, bushings, motor, crank arm, and mounting bracket are only serviced as a complete unit. If any part of this assembly is faulty or damaged, the entire unit must be replaced.

WIPER MOTOR

FRONT

The two-speed permanent magnet wiper motor has an integral transmission and park switch. The motor also contains an internal automatic resetting circuit breaker to protect the motor from overloads.

The motor is secured to the wiper linkage and pivot module bracket with three screws and is protected by a rubber boot. The wiper motor output shaft passes through a hole in the module bracket, where a nut secures the wiper motor crank arm to the motor output shaft. A reinforcement and stud plate with a rubber-isolated mounting bracket extends from the cowl plenum side of the dash panel to the motor mounting bracket to provide additional support.

Wiper speed is controlled by current flow to the proper set of brushes. The wiper motor completes its

DESCRIPTION AND OPERATION (Continued)

wipe cycle when the windshield wiper switch stalk is moved to the Off position, and parks the blades in the lowest portion of the wipe pattern.

The windshield wiper motor cannot be repaired. If faulty or damaged, the entire wiper linkage and pivot module unit must be replaced. The reinforcement bracket and stud plate are available for service.

REAR

The rear wiper motor is secured to a bracket that is fastened to the liftgate inner panel, below the liftgate glass and behind the liftgate trim panel. The motor output shaft passes through the liftgate outer panel where a rubber gasket and plastic bezel unit, and a nut seal and secure the unit to the liftgate outer panel. The rear wiper arm is secured directly to the motor output shaft with a nut.

The rear wiper motor unit provides three operating modes:

- Constant wipe that operates when the rear wiper switch is turned to the On position.
- Constant wipe that operates when the rear washer switch is depressed.
- A park mode that operates the wiper motor until the blade reaches its park position when either the rear wiper switch or the ignition switch is placed in the Off position.

The rear wiper motor cannot be repaired. If faulty or damaged, the entire rear wiper motor assembly must be replaced.

WIPER SWITCH AND WASHER SWITCH**FRONT**

The windshield wiper and washer switches are mounted on the right side of the steering column (Fig. 1). The switch stalk is moved up or down to select the wiper switch mode, and pulled towards the steering wheel to activate the washer system. An intermittent wipe system control knob on the end of the switch stalk is rotated to select the desired delay interval. The windshield wiper and washer switch contains circuitry for the following functions:

- Windshield wipers
- Intermittent wiper delay relay control and logic
- Intermittent wipe relay
- Windshield washers.

The windshield wiper and washer switch cannot be repaired. If any function of the switch is faulty, or if the switch is damaged, the entire switch unit must be replaced.

REAR

The single two-function rear wiper and washer switch is installed in the instrument panel accessory switch bezel, which is located near the bottom of the

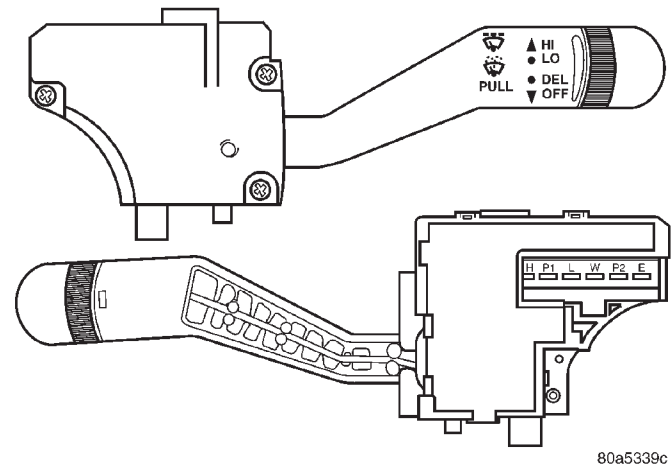

Fig. 1 Windshield Wiper Switch and Washer Switch

instrument panel center bezel area, below the heater and air conditioner controls. The rear wiper and washer switch controls the rear wiper and washer functions.

The toggle-type switch features a detent in the On position, and a momentary Wash position. The rear wiper and washer switch also has an integral illumination lamp with a serviceable bulb. The switch knob is pushed down to its detent to activate the rear wiper system, and down again to the momentary position to activate the rear washer system. Both the rear wiper and rear washer motors will operate continuously for as long as the switch is held in the momentary Wash position.

The rear wiper and washer switch cannot be repaired and, if faulty or damaged, the entire switch unit must be replaced.

WASHER RESERVOIR

A single washer fluid reservoir is used for both the standard front and optional rear washer systems. The washer fluid reservoir is secured between the left front inner and outer fender panels, above and in front of the left front wheel house.

Each washer pump and motor unit has a barbed nipple, which is installed through a rubber grommet seal inserted in a hole near the bottom of the reservoir. The washer pumps are retained by an interference fit between the barbed nipple and the grommet seal, which is a light press fit.

The washer reservoir has a separate filler neck and grommet seal. The filler neck snaps into the reservoir from the engine compartment side of the left inner fender shield. A snap-fit filler cap with an integral bail strap is fit to the reservoir filler neck. On models so equipped, the reservoir also has a hole provided for a washer fluid level sensor.

The washer reservoir, filler neck, grommet seal, and filler cap are each available for service.

DESCRIPTION AND OPERATION (Continued)

WASHER PUMP

The washer pumps and motors are mounted near the bottom of the washer reservoir. A barbed nipple on the pump housing passes through a rubber grommet seal installed in a hole near the bottom of the reservoir. The washer pump is retained by an interference fit between the barbed pump nipple and the grommet seal, which is a light press fit.

A permanently lubricated and sealed motor is coupled to a rotor-type pump. Washer fluid is gravity-fed from the reservoir to the pump. When the motor is energized, the pump pressurizes the washer fluid and forces it through the plumbing to the nozzles.

On vehicles with the optional rear wiper/washer system, the front washer pump and motor is always mounted in the lower hole of the reservoir. The washer pump and motor unit cannot be repaired. If faulty, the entire washer pump and motor unit must be replaced.

WASHER FLUID LEVEL SENSOR

The washer fluid level sensor is mounted near the front of the washer reservoir, above the two washer pumps. A barbed nipple on the sensor is press-fit into a rubber grommet seal installed in a hole in the front of the reservoir.

When the fluid level in the reservoir falls below the pivoting float on the sensor, the float changes position and closes the internal switch contacts of the sensor. Refer to Group 8E - Instrument Panel Systems for diagnosis of the low washer fluid warning lamp and circuit, including the sensor.

The washer fluid level sensor cannot be repaired. If faulty or damaged, the sensor unit must be replaced.

WASHER NOZZLE AND PLUMBING**FRONT**

Pressurized washer fluid is fed through a single hose, attached to a barbed nipple on the front washer pump. The hose is routed to a tee fitting located in the cowl plenum area, beneath the cowl plenum cover/grille panel. Hoses from the tee fitting are routed to the two nozzles, which are riveted into openings in the cowl plenum cover/grille panel below the windshield.

The two fluidic washer nozzles are not adjustable. The nozzles and hose fittings cannot be repaired and, if faulty or damaged, they must be replaced.

REAR

Pressurized washer fluid is fed through a single hose, attached to a barbed nipple on the rear washer pump. The hose is routed from the front of the vehicle to the liftgate with the body wire harness.

Located at the highest point of the supply hose routing, beneath the liftgate opening upper header garnish moulding, the hose connects to a check valve. The check valve prevents washer fluid drain-back or siphoning from occurring. From the check valve, another single hose is routed through a grommet to the liftgate, where it is connected to a nipple that protrudes from the inside of the rear wiper motor output shaft bezel.

The washer fluid passes through the bezel nipple to the outside of the liftgate. There a single hose is connected to a nipple on the outside of the rear wiper motor output shaft bezel. The hose is routed through a plastic trough-like guard snapped to the underside of the rear wiper arm. The hose is then attached to the single rear washer nozzle. The nozzle snaps into place on the rear wiper arm.

The rear washer nozzle cannot be adjusted. The nozzle, bezel, check valve, and hose fittings cannot be repaired and, if faulty or damaged, they must be replaced.

DIAGNOSIS AND TESTING**WIPER SYSTEM****FRONT**

For circuit descriptions and diagrams, refer to 8W-53 - Wipers in Group 8W - Wiring Diagrams.

WARNING: ON VEHICLES EQUIPPED WITH AIR-BAGS, REFER TO GROUP 8M - PASSIVE RESTRAINT SYSTEMS BEFORE ATTEMPTING ANY STEERING WHEEL, STEERING COLUMN, OR INSTRUMENT PANEL COMPONENT DIAGNOSIS OR SERVICE. FAILURE TO TAKE THE PROPER PRECAUTIONS COULD RESULT IN ACCIDENTAL AIR-BAG DEPLOYMENT AND POSSIBLE PERSONAL INJURY.

(1) Check the circuit breaker in the junction block. If OK, go to Step 2. If not OK, replace the faulty circuit breaker.

(2) Disconnect and isolate the battery negative cable. Unplug the windshield wiper switch wire harness connector. Connect the battery negative cable. Turn the ignition switch to the On position. Check for battery voltage at the fused ignition switch output (run/acc) circuit cavity of the wiper switch wire harness connector. If OK, go to Step 3. If not OK, repair the open circuit to the junction block as required.

(3) If the problem being diagnosed involves only the pulse wipe, wipe-after-wash, or intermittent wipe modes, go to Step 4. If not, go to Step 5.

DIAGNOSIS AND TESTING (Continued)

(4) Turn the ignition switch to the Off position. Disconnect and isolate the battery negative cable. Check for continuity between the ground circuit cavity of the wiper switch wire harness connector and a good ground. There should be continuity. If OK, replace the faulty switch. If not OK, repair the open circuit to ground as required.

(5) Turn the ignition switch to the Off position. Disconnect and isolate the battery negative cable. Remove the windshield wiper and washer switch and check the switch continuity. See Wiper Switch and Washer Switch in the Diagnosis and Testing section of this group for the procedures. If OK, go to Step 6. If not OK, replace the faulty switch.

(6) Unplug the windshield wiper motor wire harness connector. Check for continuity between the ground circuit cavity in the body half of the wiper motor wire harness connector and a good ground. There should be continuity. If OK, go to Step 7. If not OK, repair the open circuit to ground as required.

(7) Connect the battery negative cable. Turn the ignition switch to the On position. Check for battery voltage at the fused ignition switch output (run/acc) circuit cavity in the body half of the wiper motor wire harness connector. If OK, go to Step 8. If not OK, repair the open circuit to the junction block as required.

(8) Turn the ignition switch to the Off position. Disconnect and isolate the battery negative cable. With the windshield wiper and washer switch wire harness connector still unplugged, check the cavities for each of the following circuits in the body half of the wiper motor wire harness connector for continuity to ground. In each case, there should be no continuity. If OK, go to Step 9. If not OK, repair the short circuit as required.

- Wiper park switch sense
- Wiper switch low speed output
- Wiper switch high speed output.

(9) Check for continuity between the cavities in the body half of the wiper motor wire harness connector and the cavities in the windshield wiper and washer switch wire harness connector for each of the following circuits. In each case, there should be continuity. If OK, replace the faulty wiper motor. If not OK, repair the open circuit as required.

- Wiper park switch sense
- Wiper switch low speed output
- Wiper switch high speed output.

REAR

For circuit descriptions and diagrams, refer to 8W-53 - Wipers in Group 8W - Wiring Diagrams.

WARNING: ON VEHICLES EQUIPPED WITH AIR-BAGS, REFER TO GROUP 8M - PASSIVE RESTRAINT SYSTEMS BEFORE ATTEMPTING ANY STEERING WHEEL, STEERING COLUMN, OR INSTRUMENT PANEL COMPONENT DIAGNOSIS OR SERVICE. FAILURE TO TAKE THE PROPER PRECAUTIONS COULD RESULT IN ACCIDENTAL AIR-BAG DEPLOYMENT AND POSSIBLE PERSONAL INJURY.

(1) Check the fuse in the junction block. If OK, go to Step 2. If not OK, repair the shorted circuit or component as required and replace the faulty fuse.

(2) Disconnect and isolate the battery negative cable. Remove the accessory switch bezel and unplug the wire harness connector from the rear wiper and washer switch. Connect the battery negative cable. Turn the ignition switch to the On position. Check for battery voltage at the fused ignition switch output circuit cavity of the rear wiper and washer switch wire harness connector. If OK, go to Step 3. If not OK, repair the open circuit to the junction block as required.

(3) Turn the ignition switch to the Off position. Disconnect and isolate the battery negative cable. Check for continuity between the ground circuit cavity of the rear wiper and washer switch wire harness connector and a good ground. There should be continuity. If OK, go to Step 4. If not OK, repair the open circuit to ground as required.

(4) Test the rear wiper and washer switch continuity. See Wiper Switch and Washer Switch in the Diagnosis and Testing section of this group for the procedures. If OK, go to Step 5. If not OK, replace the faulty switch.

(5) Remove the liftgate trim panel and unplug the rear wiper motor wire harness connector. Connect the battery negative cable. Turn the ignition switch to the On position. Check for battery voltage at the fused ignition switch output (run) circuit cavity of the rear wiper motor wire harness connector. If OK, go to Step 6. If not OK, repair the open circuit to the junction block as required.

(6) Turn the ignition switch to the Off position. Disconnect and isolate the battery negative cable. Check for continuity between the ground circuit cavity of the rear wiper motor wire harness connector and a good ground. There should be continuity. If OK, go to Step 7. If not OK, repair the open circuit to ground as required.

(7) Check for continuity between the rear wiper motor control circuit cavity of the rear wiper motor wire harness connector and a good ground. There should be no continuity. If OK, go to Step 8. If not OK, repair the short circuit as required.

DIAGNOSIS AND TESTING (Continued)

(8) Check for continuity between the rear wiper motor control circuit cavities of the rear wiper motor wire harness connector and the rear wiper and washer switch wire harness connector. There should be continuity. If OK, replace the faulty rear wiper motor. If not OK, repair the open circuit as required.

WASHER SYSTEM

FRONT

The diagnosis found here addresses an inoperative front washer pump. If the washer pump operates, but no washer fluid is emitted from the washer nozzles, be certain to check the fluid level in the reservoir. Check for ice or other foreign material in the reservoir, and for pinched, disconnected, broken, or incorrectly routed washer system plumbing. For circuit descriptions and diagrams, refer to 8W-53 - Wipers in Group 8W - Wiring Diagrams.

WARNING: ON VEHICLES EQUIPPED WITH AIR-BAGS, REFER TO GROUP 8M - PASSIVE RESTRAINT SYSTEMS BEFORE ATTEMPTING ANY STEERING WHEEL, STEERING COLUMN, OR INSTRUMENT PANEL COMPONENT DIAGNOSIS OR SERVICE. FAILURE TO TAKE THE PROPER PRECAUTIONS COULD RESULT IN ACCIDENTAL AIR-BAG DEPLOYMENT AND POSSIBLE PERSONAL INJURY.

(1) Turn the ignition switch to the On position. Turn the wiper switch to the Low or High speed position. Check whether the wipers operate. If OK, go to Step 2. If not OK, see the Wiper System diagnosis in this group.

(2) Turn the ignition switch to the Off position. Disconnect and isolate the battery negative cable. Unplug the front washer pump wire harness connector. Check for continuity between the ground circuit cavity of the front washer pump wire harness connector and a good ground. There should be continuity. If OK, go to Step 3. If not OK, repair the open circuit to ground as required.

(3) Connect the battery negative cable. Turn the ignition switch to the On position. Check for battery voltage at the front washer switch output circuit cavity of the front washer pump wire harness connector while actuating the washer switch. If OK, replace the faulty washer pump. If not OK, go to Step 4.

(4) Turn the ignition switch to the Off position. Disconnect and isolate the battery negative cable. Unplug the windshield wiper/washer switch wire harness connector. Check for continuity between the front washer switch output circuit cavity of the front washer pump wire harness connector and a good ground. There should be no continuity. If OK, go to Step 5. If not OK, repair the short circuit as required.

(5) Check for continuity between the front washer switch output circuit cavities of the front washer pump wire harness connector and the wiper/washer switch wire harness connector. There should be continuity. If OK, replace the faulty switch. If not OK, repair the open circuit as required.

REAR

The diagnosis found here addresses an inoperative rear washer pump. If the washer pump operates, but no washer fluid is emitted from the washer nozzle, be certain to check the fluid level in the reservoir. Check for ice or other foreign material in the reservoir, and for pinched, disconnected, broken, or incorrectly routed washer system plumbing. For circuit descriptions and diagrams, refer to 8W-53 - Wipers in Group 8W - Wiring Diagrams.

WARNING: ON VEHICLES EQUIPPED WITH AIR-BAGS, REFER TO GROUP 8M - PASSIVE RESTRAINT SYSTEMS BEFORE ATTEMPTING ANY STEERING WHEEL, STEERING COLUMN, OR INSTRUMENT PANEL COMPONENT DIAGNOSIS OR SERVICE. FAILURE TO TAKE THE PROPER PRECAUTIONS COULD RESULT IN ACCIDENTAL AIR-BAG DEPLOYMENT AND POSSIBLE PERSONAL INJURY.

(1) Turn the ignition switch to the On position. Place the rear wiper/washer switch in the Wipe position. Check whether the rear wiper is operating. If OK, go to Step 2. If not OK, see the Wiper System diagnosis in this group.

(2) Turn the ignition switch to the Off position. Disconnect and isolate the battery negative cable. Unplug the rear washer pump wire harness connector. Check for continuity between the ground circuit cavity of the rear washer pump wire harness connector and a good ground. There should be continuity. If OK, go to Step 3. If not OK, repair the open circuit to ground as required.

(3) Connect the battery negative cable. Turn the ignition switch to the On position. Check for battery voltage at the rear washer motor control circuit cavity of the rear washer pump wire harness connector while the rear washer switch is actuated. If OK, replace the faulty pump. If not OK, go to Step 4.

(4) Turn the ignition switch to the Off position. Disconnect and isolate the battery negative cable. Unplug the rear wiper/washer switch wire harness connector. Check for continuity between the rear washer motor control circuit cavity of the rear washer pump wire harness connector and a good ground. There should be no continuity. If OK, go to Step 5. If not OK, repair the short circuit as required.

DIAGNOSIS AND TESTING (Continued)

(5) Check for continuity between the rear washer motor control circuit cavities of the rear washer pump wire harness connector and the rear wiper/washer switch wire harness connector. There should be continuity. If OK, replace the faulty switch. If not OK, repair the open circuit as required.

WIPER SWITCH AND WASHER SWITCH

FRONT

Perform the diagnosis for the front wiper system and/or washer system as described in this group before testing the front wiper and washer switch. For circuit descriptions and diagrams, see 8W-53 - Wipers in Group 8W - Wiring Diagrams.

WARNING: ON VEHICLES EQUIPPED WITH AIR-BAGS, REFER TO GROUP 8M - PASSIVE RESTRAINT SYSTEMS BEFORE ATTEMPTING ANY STEERING WHEEL, STEERING COLUMN, OR INSTRUMENT PANEL COMPONENT DIAGNOSIS OR SERVICE. FAILURE TO TAKE THE PROPER PRECAUTIONS COULD RESULT IN ACCIDENTAL AIR-BAG DEPLOYMENT AND POSSIBLE PERSONAL INJURY.

- (1) Disconnect and isolate the battery negative cable.
- (2) Remove the front wiper and washer switch from the steering column and unplug the wire harness connector from the switch.
- (3) Using an ohmmeter, perform the switch continuity checks at the switch terminals as shown in the Windshield Wiper Switch and Washer Switch Continuity chart (Fig. 2).
- (4) If the switch fails any of the continuity checks, replace the faulty switch. If the switch is OK, repair the wiper system and/or washer system wire harness circuits as required.

REAR

Perform the diagnosis for the rear wiper system and/or washer system as described in this group before testing the rear wiper and washer switch. For circuit descriptions and diagrams, see 8W-53 - Wipers in Group 8W - Wiring Diagrams.

WARNING: ON VEHICLES EQUIPPED WITH AIR-BAGS, REFER TO GROUP 8M - PASSIVE RESTRAINT SYSTEMS BEFORE ATTEMPTING ANY STEERING WHEEL, STEERING COLUMN, OR INSTRUMENT PANEL COMPONENT DIAGNOSIS OR SERVICE. FAILURE TO TAKE THE PROPER PRECAUTIONS COULD RESULT IN ACCIDENTAL AIR-BAG DEPLOYMENT AND POSSIBLE PERSONAL INJURY.

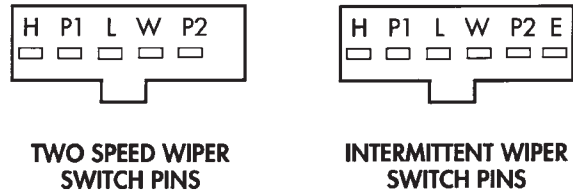

SWITCH POSITION	CONTINUITY BETWEEN
OFF	PIN P2 and PIN L
LOW	PIN P1 and PIN L
HIGH	PIN P1 and PIN H
WASH	PIN P1 and PIN W
INTERMITTENT	CANNOT BE CHECKED

948K-38

Fig. 2 Windshield Wiper Switch and Washer Switch Continuity

- (1) Remove the accessory switch bezel from the instrument panel and unplug the rear wiper and washer switch wire harness connector.
- (2) Using an ohmmeter, check the rear wiper and washer switch continuity at the switch terminals as shown in the Rear Wiper Switch and Washer Switch Continuity chart (Fig. 3).

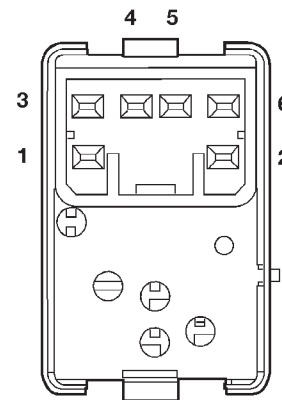

SWITCH POSITION	CONTINUITY BETWEEN
OFF	1 AND 4
WIPE	4 AND 5
WASH	2 AND 5, 4 AND 5
ILLUMINATION LAMP	1 AND 3

80a5035e

Fig. 3 Rear Wiper Switch and Washer Switch Continuity

- (3) If the switch fails any of the continuity checks, replace the faulty switch. If the switch is OK, repair the rear wiper system and/or washer system wire harness circuits as required.

REMOVAL AND INSTALLATION

WIPER BLADE

FRONT

NOTE: The notched retainer end of the wiper element should always be oriented towards the end of the wiper blade that is nearest to the wiper pivot.

(1) Lift the wiper arm to raise the wiper blade and element off of the windshield glass.

(2) To remove the wiper blade from the wiper arm, push the release tab under the arm tip and slide the blade away from the tip towards the pivot end of the arm (Fig. 4).

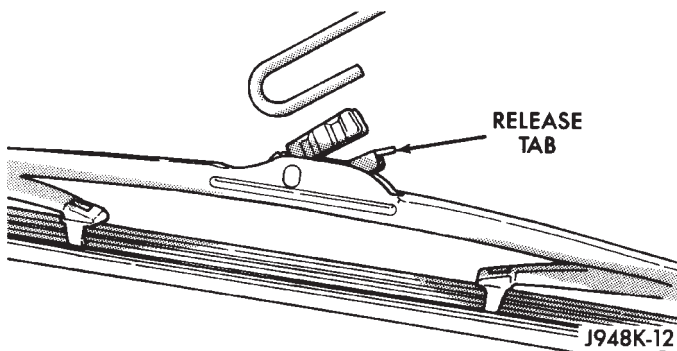

Fig. 4 Wiper Blade Remove/Install - Typical

(3) To install the wiper blade on the wiper arm, slide the blade retainer into the U-shaped formation on the tip of the wiper arm until the release tab snaps into its locked position. Be certain that the notched retainer for the wiper element is oriented towards the end of the wiper blade that is nearest to the wiper pivot.

REAR

NOTE: The notched retainer end of the wiper element should always be oriented towards the end of the wiper blade that is nearest to the wiper pivot.

(1) Lift the rear wiper arm to raise the wiper blade and element off of the rear liftglass.

(2) To remove the wiper blade from the wiper arm, push the release tab under the arm tip and slide the blade away from the tip towards the rear wiper motor output shaft end of the arm (Fig. 4).

(3) To install the wiper blade on the wiper arm, slide the blade retainer into the U-shaped formation on the tip of the wiper arm until the release tab snaps into its locked position. Be certain that the notched retainer for the wiper element is oriented towards the end of the wiper blade that is nearest to the rear wiper motor output shaft.

WIPER ARM

CAUTION: The use of a screwdriver or other prying tool to remove a wiper arm may distort it. This distortion could allow the arm to come off of the pivot shaft, regardless of how carefully it is installed.

FRONT

(1) Lift the wiper arm to permit the latch to be pulled out to its holding position, then release the arm (Fig. 5). The arm will remain off the windshield with the latch in this position.

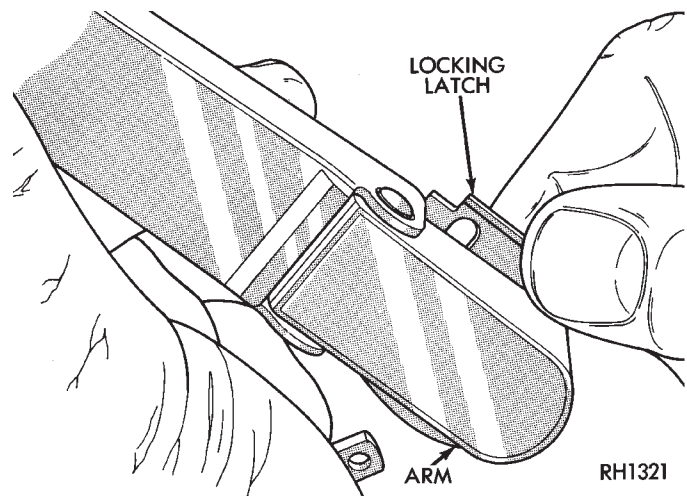
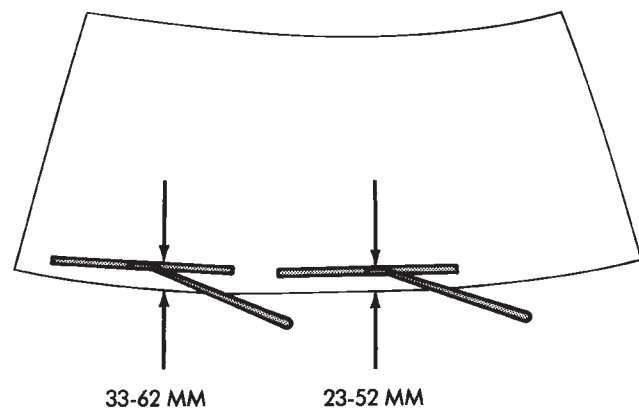

Fig. 5 Wiper Arm Remove/Install

(2) Remove the arm from the pivot using a rocking motion.

(3) Install the arm and blade with the wiper motor in the Park position. See the Front Wiper Arm Installation illustration (Fig. 6).



J898K-29

Fig. 6 Front Wiper Arm Installation

REMOVAL AND INSTALLATION (Continued)

(4) Mount the arms on the pivot shafts so that the distance from the lower edge of the wiper arm tip to the upper edge of the lower windshield moulding is:

- 23 to 52 mm (0.90 to 2.04 inch) on the driver side
- 33 to 62 mm (1.29 to 2.44 inch) on the passenger side.

(5) Lift the wiper arm away from the windshield slightly to relieve the spring tension on the latch. Push the latch into the locked position and slowly release the arm until the wiper blade rests on the windshield.

(6) Operate the wipers with the windshield glass wet, then turn the wiper switch to the Off position. Check for the correct wiper arm positioning and readjust if required.

REAR

(1) Disconnect the washer nozzle hose and clip from the external nipple of the rear wiper motor output shaft bezel.

(2) Lift the wiper arm pivot cover and remove the retaining nut (Fig. 7).

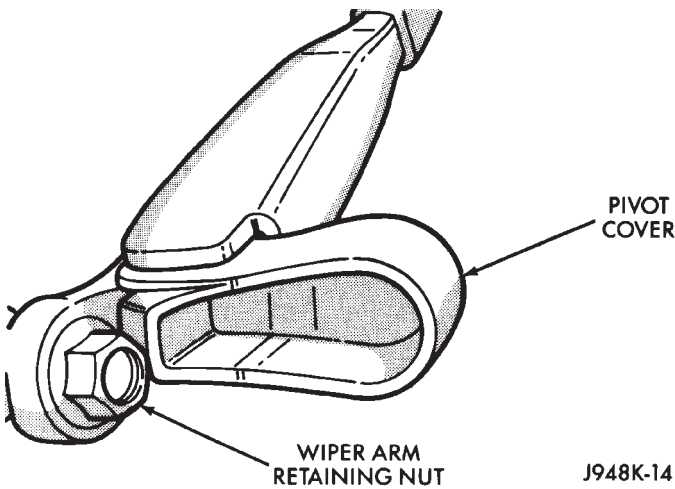

Fig. 7 Rear Wiper Arm Remove/Install

(3) Remove the wiper arm from the motor output shaft using a rocking motion.

(4) Install the rear wiper arm with the wiper motor in the Park position. Place the rear wiper blade on the glass so that it is parallel to the liftgate glass opening, and install the wiper arm retaining nut.

(5) Operate the rear wiper with the liftgate glass wet, then turn the rear wiper switch to the Off position so that the blade moves to the Park position.

(6) The measurement from the tip of the blade should now be from 27 to 35 mm (1.06 to 1.38 inch) above the upper edge of the lower liftgate glass seal (Fig. 8). Check for the correct wiper arm positioning and readjust if required.

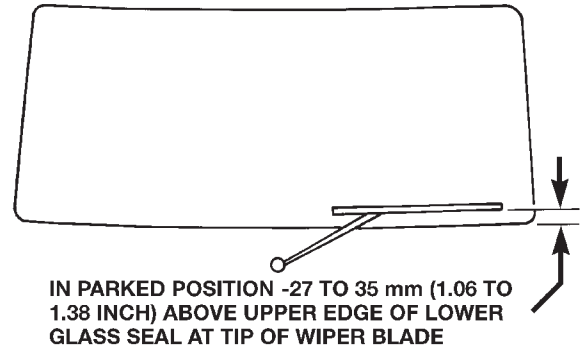

80ab5cc2

Fig. 8 Rear Wiper Arm Installation

(7) Tighten the wiper arm retaining nut to 18 N·m (160 in. lbs.) and close the pivot cover.

WIPER LINKAGE AND PIVOT

The wiper linkage and pivots can only be removed from or installed in the vehicle as a unit with the wiper motor. See Wiper Motor in this group for the service procedures.

WIPER MOTOR

FRONT

(1) Disconnect and isolate the battery negative cable.

(2) Remove the wiper arms from the wiper pivots. See Wiper Arm in this group for the procedures.

(3) Remove the eight screws that secure the cowl plenum cover/grille panel and screen to the cowl top panel (Fig. 9).

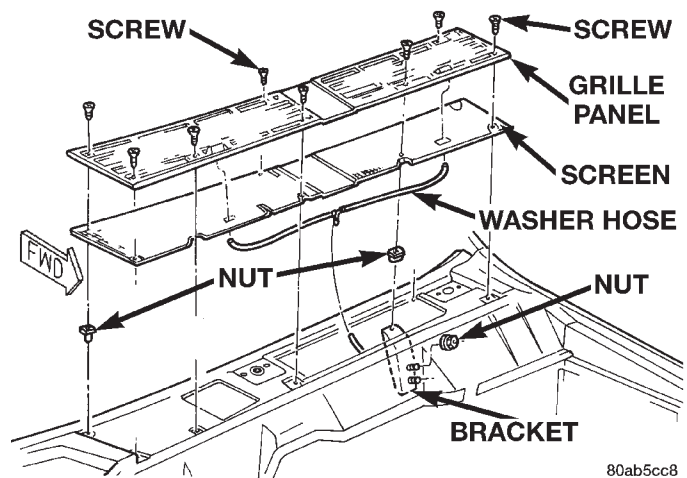

80ab5cc8

Fig. 9 Cowl Plenum Cover/Grille Panel Remove/Install

(4) Carefully lift the cowl plenum cover/grille panel and screen from the vehicle far enough to access the windshield washer plumbing. Use care so as not to

REMOVAL AND INSTALLATION (Continued)

damage the paint around the pivot openings of the panel.

(5) Disconnect the windshield washer supply hose and the passenger side washer nozzle hose from the washer nozzle supply hose tee fitting.

(6) Remove the cowl plenum cover/grille panel and screen from the vehicle.

(7) Reach into the cowl plenum and unplug the wiper motor wire harness connector.

(8) Open and support the hood

(9) Remove the two nuts that secure the studs of the wiper module mounting bracket and reinforcement to the dash panel (Fig. 10).

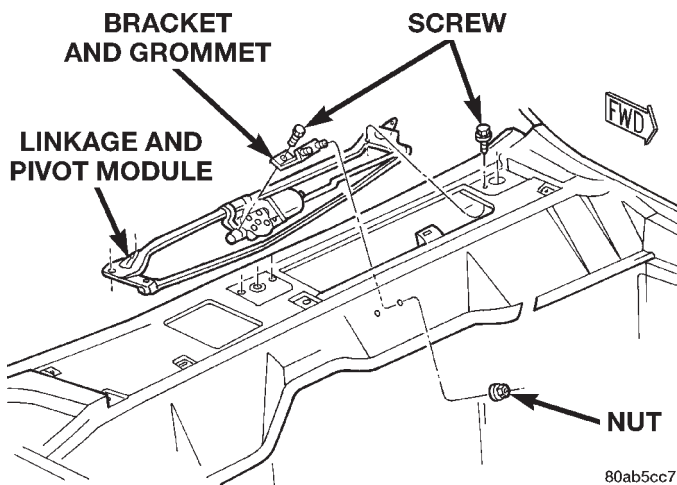

Fig. 10 Wiper Linkage Module Remove/Install

(10) Remove the four screws near the wiper pivots that secure the wiper module to the cowl plenum panel.

(11) Remove the wiper module from the cowl plenum as a unit.

(12) Reverse the removal procedures to install. Tighten the mounting hardware as follows:

- Wiper module mounting screws - 6 N·m (50 in. lbs.)
- Wiper module mounting bracket and reinforcement nuts - 6 N·m (50 in. lbs.).

REAR

(1) Disconnect and isolate the battery negative cable.

(2) From the outside of the liftgate glass, remove the rear wiper arm from the rear wiper motor output shaft. See Wiper Arm in this group for the procedures.

(3) From the outside of the liftgate, remove the rear wiper motor output shaft nut (Fig. 11).

(4) Pull the rear wiper motor output shaft bezel and rubber gasket away from the liftgate far enough to access the washer supply hose.

(5) Disconnect the washer supply hose from the internal nipple on the bezel.

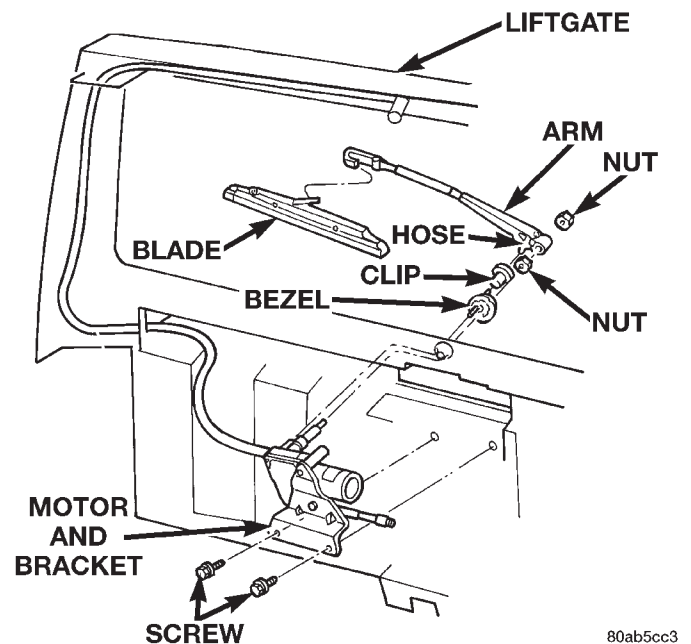

Fig. 11 Rear Wiper Motor Remove/Install

(6) Remove the bezel and rubber gasket from the motor output shaft.

(7) Remove the liftgate trim panel from the liftgate. Refer to Group 23 - Body for the procedures.

(8) Unplug the rear wiper motor wire harness connector.

(9) Remove the two screws that secure the rear wiper motor mounting bracket to the liftgate inner panel.

(10) Remove the rear wiper motor and mounting bracket from the liftgate as a unit.

(11) Reverse the removal procedures to install. Tighten the mounting hardware as follows:

- Rear wiper motor mounting bracket screws - 5 N·m (45 in. lbs.)
- Rear wiper motor output shaft retaining nut - 3 N·m (27 in. lbs.).

WIPER SWITCH AND WASHER SWITCH

FRONT

WARNING: ON VEHICLES EQUIPPED WITH AIRBAGS, REFER TO GROUP 8M - PASSIVE RESTRAINT SYSTEMS BEFORE ATTEMPTING ANY STEERING WHEEL, STEERING COLUMN, OR INSTRUMENT PANEL COMPONENT DIAGNOSIS OR SERVICE. FAILURE TO TAKE THE PROPER PRECAUTIONS COULD RESULT IN ACCIDENTAL AIRBAG DEPLOYMENT AND POSSIBLE PERSONAL INJURY.

REMOVAL AND INSTALLATION (Continued)

(1) Disconnect and isolate the battery negative cable.

(2) Remove the knee blocker from the instrument panel. See Knee Blocker in Group 8E - Instrument Panel Systems for the procedures.

(3) If the vehicle is so equipped, move the tilt steering column to the fully raised position.

(4) Insert the key in the ignition lock cylinder and turn the ignition switch to the On position.

(5) Insert a small screwdriver or pin punch through the access hole in the lower steering column shroud and depress the ignition lock cylinder retaining tumbler (Fig. 12).

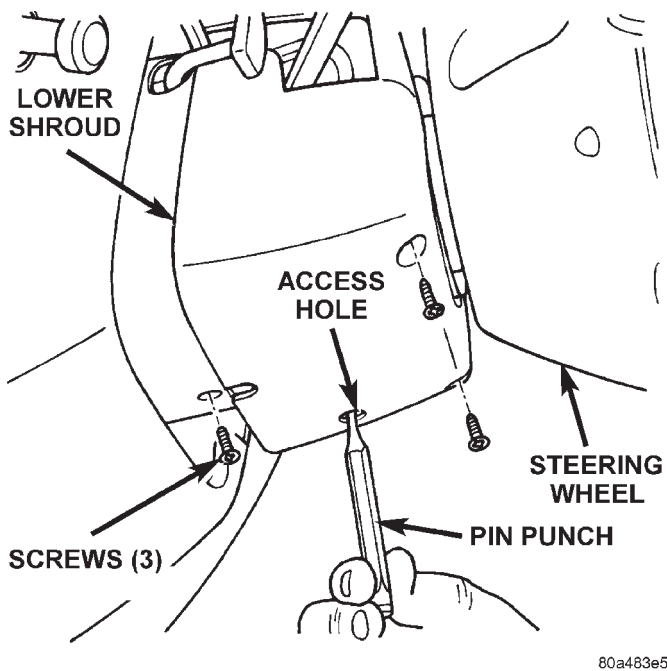

80a483e5

Fig. 12 Steering Column Shrouds Remove/Install

(6) While holding the retaining tumbler depressed, pull the ignition lock cylinder and key out of the ignition lock housing.

(7) Remove the three screws that secure the lower steering column shroud to the upper shroud.

(8) If the vehicle is so equipped, move the tilt steering column to the fully lowered position.

(9) If the vehicle is so equipped, loosen the two nuts that secure the non-tilt steering column upper mounting bracket to the dash panel steering column support bracket studs. Lower the column far enough to remove the upper steering column shroud.

(10) Remove both the upper and lower shrouds from the steering column.

(11) Remove the two screws that secure the multi-function switch water shield and bracket to the top of the steering column (Fig. 13).

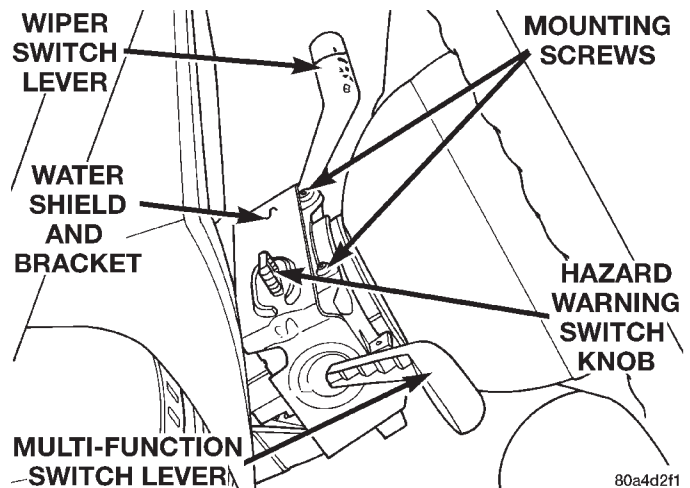

80a4d2f1

Fig. 13 Water Shield Upper Screws Remove/Install

(12) Remove the one screw located below the multi-function switch lever that secures the multi-function switch water shield and bracket to the steering column (Fig. 14).

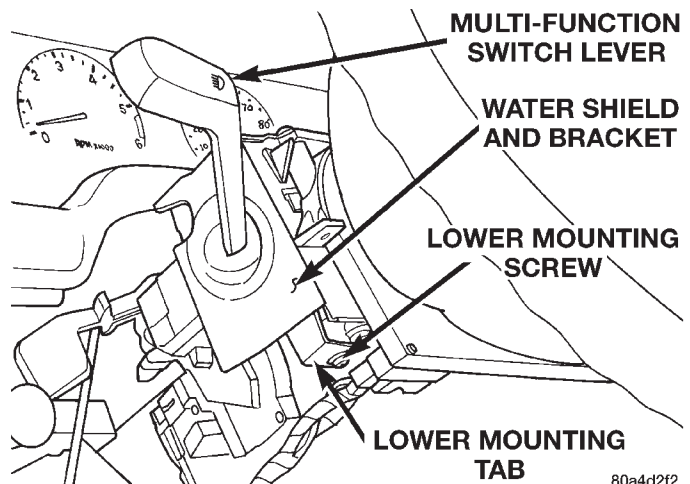

80a4d2f2

Fig. 14 Water Shield Lower Screw Remove/Install

(13) Gently pull the lower mounting tab of the multi-function switch water shield bracket away from the steering column far enough to clear the screw boss below the multi-function switch lever.

(14) Lift the water shield and bracket with the multi-function switch off of the left side of the steering column as a unit and move it out of the way. If the vehicle is equipped with the optional tilt steering column, lifting gently upward on the tilt release lever will provide additional clearance to ease multi-function switch removal.

(15) Gently pull the windshield wiper and washer switch up and away from the right side of the steering column far enough to access the wire harness connector.

(16) Unplug the wire harness connector from the windshield wiper and washer switch.

REMOVAL AND INSTALLATION (Continued)

(17) Remove the windshield wiper and washer switch from the steering column.

(18) Reverse the removal procedures to install. Tighten the upper switch mounting screws to 2.2 N·m (20 in. lbs.). Tighten the lower switch water shield and bracket screw to 1.1 N·m (10 in. lbs.). Tighten the non-tilt steering column mounting nuts to 22 N·m (200 in. lbs.) and the steering column shroud mounting screws to 2 N·m (18 in. lbs.).

REAR

WARNING: ON VEHICLES EQUIPPED WITH AIR-BAGS, REFER TO GROUP 8M - PASSIVE RESTRAINT SYSTEMS BEFORE ATTEMPTING ANY STEERING WHEEL, STEERING COLUMN, OR INSTRUMENT PANEL COMPONENT DIAGNOSIS OR SERVICE. FAILURE TO TAKE THE PROPER PRECAUTIONS COULD RESULT IN ACCIDENTAL AIR-BAG DEPLOYMENT AND POSSIBLE PERSONAL INJURY.

(1) Disconnect and isolate the battery negative cable.

(2) Remove the center bezel from the instrument panel. See Instrument Panel Center Bezel in Group 8E - Instrument Panel Systems for the procedures.

(3) Remove the three screws that secure the accessory switch bezel to the instrument panel (Fig. 15).

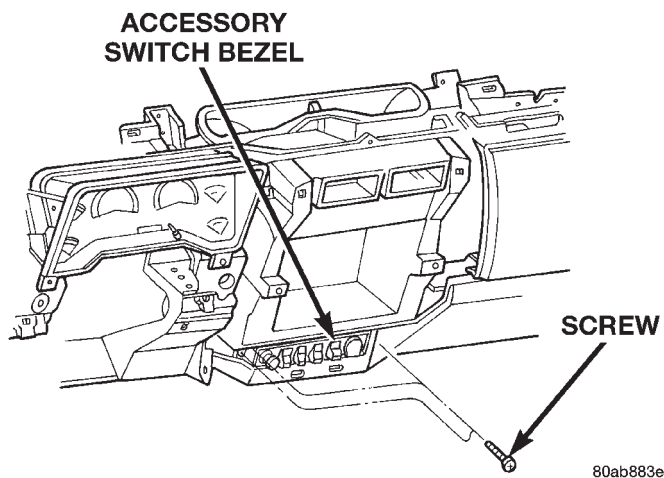

Fig. 15 Accessory Switch Bezel Remove/Install

(4) Pull the accessory switch bezel out from the instrument panel far enough to access the wire harness connectors.

(5) Unplug the wire harness connectors from the rear of the accessory switches, the cigar lighter and the power outlet.

(6) Remove the accessory switch bezel from the instrument panel.

(7) With a small thin-bladed screwdriver, gently pry the snap clips at the top and bottom of the rear

wiper and washer switch receptacle on the back of the accessory switch bezel and pull the switch out of the bezel.

(8) Reverse the removal procedures to install. Be certain that both of the switch snap clip retainers in the receptacle on the back of the accessory switch bezel are fully engaged. Tighten the mounting screws to 2.2 N·m (20 in. lbs.).

WASHER SYSTEM

WASHER RESERVOIR

(1) Disconnect and isolate the battery negative cable.

(2) The washer reservoir filler neck is held in the reservoir by an interference fit. Remove the filler neck from the reservoir using a combination of pulling, rocking and twisting actions (Fig. 16).

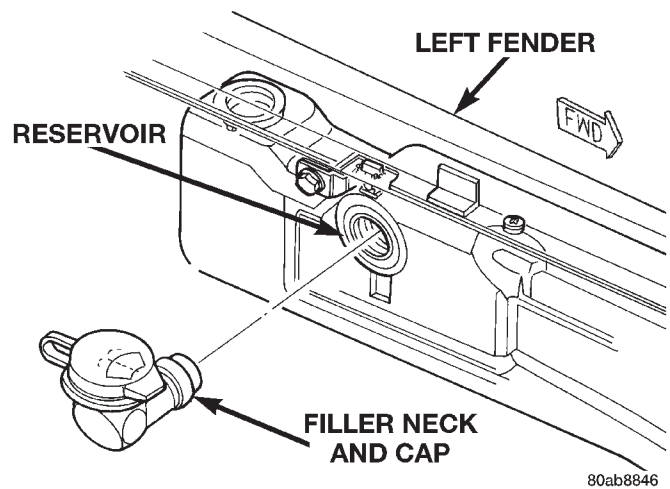

Fig. 16 Washer Reservoir Filler Neck Remove/Install

(3) Remove the engine air filter housing. Refer to Group 14 - Fuel System for the procedures.

(4) Remove the two screws that secure the washer reservoir to the inner fender shield (Fig. 17).

(5) Raise and support the vehicle.

(6) Remove the left front inner wheelhouse splash shield. Refer to Group 23 - Body for the procedures.

(7) Remove the washer supply hose(s) from the washer pump(s) and drain the washer fluid from the reservoir into a clean container for reuse.

(8) Unplug the wire harness connectors from the washer pump(s) and the washer fluid level sensor.

(9) Slide the reservoir slightly towards the rear of the vehicle to release the two hooks from the inner fender ledge slots.

(10) Lower the front of the washer reservoir and slide the unit forward to remove it from the vehicle.

(11) Reverse the removal procedures to install. Tighten the reservoir mounting screws to 3 N·m (26 in. lbs.).

REMOVAL AND INSTALLATION (Continued)

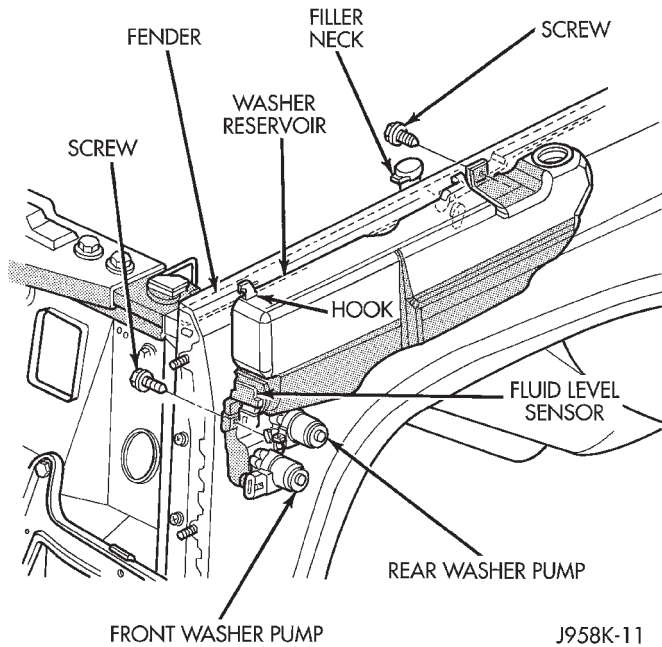

Fig. 17 Washer Reservoir Remove/Install

WASHER PUMP

- (1) Disconnect and isolate the battery negative cable.
- (2) Raise and support the vehicle.
- (3) Remove the left front inner wheelhouse splash shield. Refer to Group 23 - Body for the procedures.
- (4) Remove the washer supply hose(s) from the barbed outlet nipple of the washer pump(s) and drain the washer fluid from the reservoir into a clean container for reuse.
- (5) Unplug the wire harness connectors from the washer pump(s).
- (6) Using a trim stick or another suitable wide flat-bladed tool, gently pry the barbed inlet nipple of the washer pump out of the rubber grommet seal in the reservoir. Care must be taken not to damage the reservoir.
- (7) Remove the rubber grommet seal from the reservoir and discard.
- (8) Reverse the removal procedures to install. Always use a new rubber grommet seal on the reservoir.

WASHER FLUID LEVEL SENSOR

- (1) Remove the washer reservoir from the vehicle. See Washer Reservoir in this group for the procedures.

NOTE: The pivoting float of the washer fluid sensor must be in a horizontal position within the reservoir in order to be removed. With the reservoir empty and in an upright position, the pivoting float will ori-

ent itself to the horizontal position when the sensor connector is pointed straight downwards.

- (2) Using a trim stick or another suitable wide flat-bladed tool, gently pry the washer fluid level sensor out of the rubber grommet seal. Care must be taken not to damage the reservoir.
- (3) Remove the rubber grommet seal from the reservoir and discard.
- (4) Reverse the removal procedures to install. Always use a new rubber grommet seal on the reservoir.

WASHER NOZZLE

FRONT

- (1) Remove the wiper arms from the wiper pivots. See Wiper Arm in this group for the procedures.
- (2) Remove the eight screws that secure the cowl plenum cover/grille panel and screen to the cowl top panel (Fig. 18).

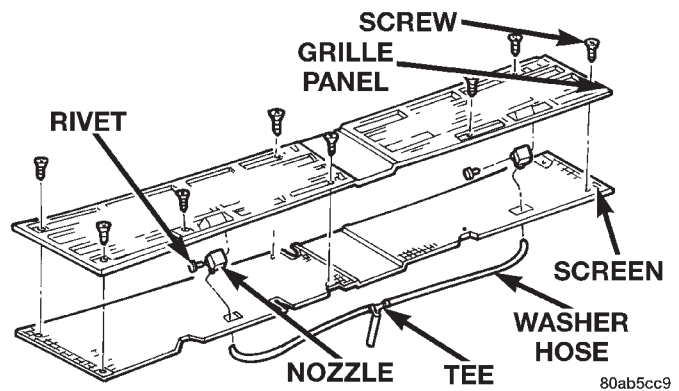

Fig. 18 Front Washer Nozzles Remove/Install

- (3) Carefully lift the cowl plenum cover/grille panel and screen from the vehicle far enough to access the windshield washer plumbing. Use care so as not to damage the paint around the pivot openings of the panel.
- (4) Disconnect the windshield washer supply hose and the passenger side washer nozzle hose from the washer nozzle supply hose tee fitting.
- (5) Remove the cowl plenum cover/grille panel and screen from the vehicle.
- (6) From the underside of the cowl plenum cover/grille panel, disconnect the washer hose from the nozzle fitting.
- (7) From the underside of the cowl plenum cover/grille panel, remove the rivet that secures the nozzle to the opening in the cowl plenum cover/grille panel.
- (8) Remove the washer nozzle from the cowl plenum cover/grille panel.
- (9) Reverse the removal procedures to install.

REMOVAL AND INSTALLATION (Continued)

REAR

(1) Unsnap the rear washer nozzle from the rear wiper arm (Fig. 19).

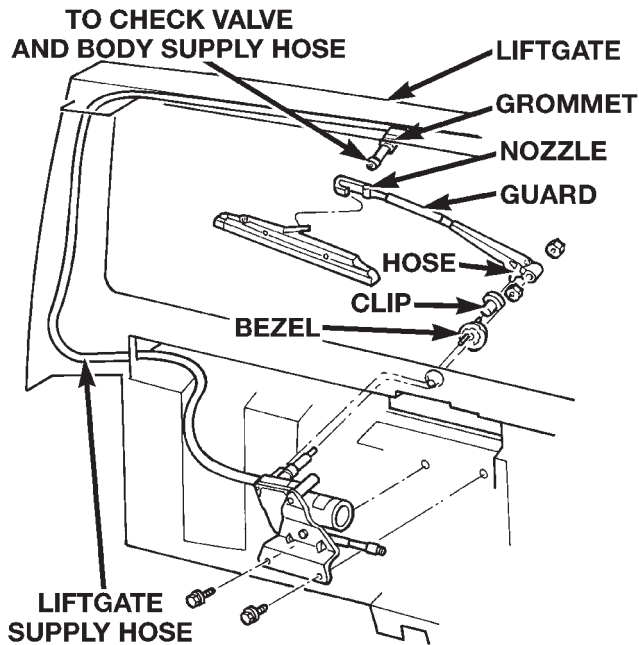

80ab8848

Fig. 19 Rear Washer Nozzle Remove/Install

- (2) Disconnect the washer supply hose from the barbed rear washer nozzle nipple.
- (3) Reverse the removal procedures to install.

CHECK VALVE

(1) Remove the four screws that secure the liftgate opening upper garnish moulding to the upper liftgate opening reinforcement.

(2) Using a trim stick or another suitable wide-bladed flat tool, gently pry the liftgate opening upper garnish moulding away from the upper liftgate opening reinforcement to release the snap clip retainers.

(3) Remove the garnish moulding from the upper liftgate opening.

(4) Disconnect the liftgate half of the washer supply hose from the barbed nipple of the rear washer system check valve.

(5) Disconnect the body half of the washer supply hose from the other barbed nipple of the rear washer system check valve.

(6) Remove the check valve from the vehicle.

(7) When reinstalling the check valve, be certain the valve is properly oriented within the system flow (Fig. 20).

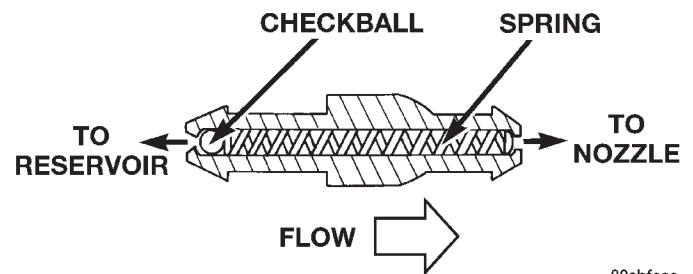

80abfece

Fig. 20 Rear Washer System Check Valve

- (8) Reverse the remaining removal procedures to complete the installation.