

VEHICLE THEFT/SECURITY SYSTEMS

CONTENTS

	page		page
GENERAL INFORMATION		DIAGNOSIS AND TESTING	
INTRODUCTION	1	SENTRY KEY IMMOBILIZER SYSTEM	3
SENTRY KEY IMMOBILIZER SYSTEM	1	SERVICE PROCEDURES	
DESCRIPTION AND OPERATION		SENTRY KEY IMMOBILIZER SYSTEM	
SENTRY KEY IMMOBILIZER MODULE	1	TRANSPONDER PROGRAMMING	4
SENTRY KEY IMMOBILIZER SYSTEM		REMOVAL AND INSTALLATION	
INDICATOR LAMP	3	SENTRY KEY IMMOBILIZER MODULE	4
SENTRY KEY IMMOBILIZER TRANSPONDER ..	2		

GENERAL INFORMATION

INTRODUCTION

The Sentry Key Immobilizer System (SKIS) is available factory-installed optional equipment for this model. Following are some general descriptions of the features and components of the SKIS. Refer to the vehicle owner's manual for more information on the use and operation of the SKIS. Refer to 8W-30 - Fuel/Ignition System in Group 8W - Wiring Diagrams for complete circuit descriptions and diagrams.

SENTRY KEY IMMOBILIZER SYSTEM

The Sentry Key Immobilizer System (SKIS) is designed to provide passive protection against unauthorized vehicle use by preventing the engine from operating while the system is armed. The primary components of this system are the Sentry Key Immobilizer Module (SKIM), the Sentry Key transponder, the SKIS indicator lamp, and the Powertrain Control Module (PCM).

The SKIM is installed on the steering column near the ignition lock cylinder. The transponder is located under the molded rubber cap on the head of the ignition key. The SKIS indicator lamp is located in the instrument cluster.

The SKIS includes two valid Sentry Key transponders from the factory. If the customer wishes, additional non-coded blank Sentry Keys are available. These blank keys can be cut to match a valid ignition key, but the engine will not start unless the key transponder is also programmed to the vehicle. The SKIS will recognize no more than eight valid Sentry Key transponders at any one time.

The SKIS performs a self-test each time the ignition switch is turned to the On position, and will store Diagnostic Trouble Codes (DTCs) if a system malfunction is detected. The SKIS can be diagnosed,

and any stored DTC can be retrieved using a DRB scan tool as described in the proper Diagnostic Procedures manual.

DESCRIPTION AND OPERATION

SENTRY KEY IMMOBILIZER MODULE

The Sentry Key Immobilizer Module (SKIM) contains a Radio Frequency (RF) transceiver and a central processing unit, which includes the Sentry Key Immobilizer System (SKIS) program logic. The SKIS programming enables the SKIM to program and retain in memory the codes of at least two, but no more than eight electronically coded Sentry Key transponders. The SKIS programming also enables the SKIM to communicate over the Chrysler Collision Detection (CCD) data bus network with the Powertrain Control Module (PCM), the instrument cluster and/or the DRB scan tool.

The SKIM transmits and receives RF signals through a tuned antenna enclosed within a molded plastic ring formation that is integral to the SKIM housing. When the SKIM is properly installed on the steering column, the antenna ring is oriented around the circumference of the ignition lock cylinder housing. This antenna ring must be located within eight millimeters (0.31 inches) of the Sentry Key in order to ensure proper RF communication between the SKIM and the Sentry Key transponder.

For added system security, each SKIM is programmed with a unique "Secret Key" code and a security code. The SKIM keeps the "Secret Key" code in memory and sends the code over the CCD data bus to the PCM, which also keeps this code in its memory. The SKIM also sends the "Secret Key" code to each of the programmed Sentry Key transponders. The security code is used by the assembly plant to access the SKIS for initialization, or by the dealer

DESCRIPTION AND OPERATION (Continued)

technician to access the system for service. The SKIM also stores in its memory the Vehicle Identification Number (VIN), which it learns through a CCD data bus message from the PCM during initialization.

The SKIM and the PCM both use software that includes a rolling code algorithm strategy, which helps to reduce the possibility of unauthorized SKIS disarming. The rolling code algorithm ensures security by preventing an override of the SKIS through the unauthorized substitution of the SKIM or the PCM. However, the use of this strategy also means that replacement of either the SKIM or the PCM units will require a system initialization procedure to restore system operation.

When the ignition switch is turned to the On or Start positions, the SKIM transmits an RF signal to excite the Sentry Key transponder. The SKIM then listens for a return RF signal from the transponder of the Sentry Key that is inserted in the ignition lock cylinder. If the SKIM receives an RF signal with valid "Secret Key" and transponder identification codes, the SKIM sends a "valid key" message to the PCM over the CCD data bus. If the SKIM receives an invalid RF signal or no response, it sends "invalid key" messages to the PCM. The PCM will enable or disable engine operation based upon the status of the SKIM messages.

The SKIM also sends messages to the instrument cluster over the CCD data bus network to control the SKIS indicator lamp. The SKIM sends messages to the instrument cluster to turn the lamp on for about three seconds when the ignition switch is turned to the On position as a bulb test. After completion of the bulb test, the SKIM sends bus messages to keep the lamp off for a duration of about one second. Then the SKIM sends messages to turn the lamp on or off based upon the results of the SKIS self-tests. If the SKIS indicator lamp comes on and stays on after the bulb test, it indicates that the SKIM has detected a system malfunction and/or that the SKIS has become inoperative.

If the SKIM detects an invalid key when the ignition switch is turned to the On position, it sends messages to the instrument cluster to flash the SKIS indicator lamp. The SKIM can also send messages to the instrument cluster to flash the lamp and to generate a single audible chime tone. These functions serve as an indication to the customer that the SKIS has been placed in its "Customer Learn" programming mode. See Sentry Key Immobilizer System Transponder Programming in this group for more information on the "Customer Learn" programming mode.

For diagnosis or initialization of the SKIM and the PCM, a DRB scan tool and the proper Diagnostic

Procedures manual are required. The SKIM cannot be repaired and, if faulty or damaged, the unit must be replaced.

SENTRY KEY IMMOBILIZER TRANSPONDER

The Sentry Key Immobilizer System (SKIS) uses a transponder that is integral to each of the two ignition keys that are supplied with the vehicle when it is shipped from the factory. The transponder chip is insulated within a nylon mount inserted in the head of the key, and invisible beneath a molded rubber cap (Fig. 1).

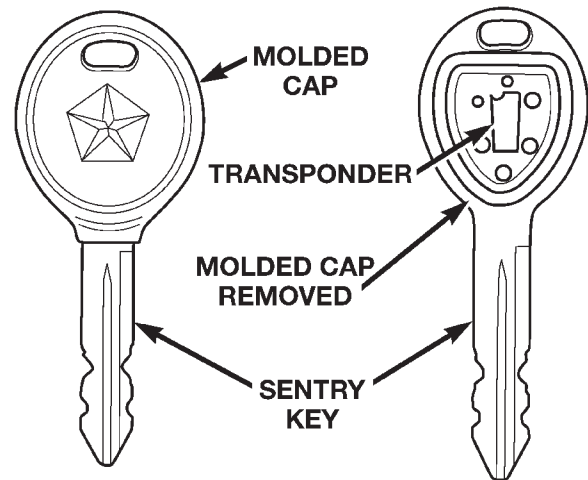

80b5cb75

Fig. 1 Sentry Key Immobilizer Transponder

Each Sentry Key transponder has a unique transponder identification code programmed into it by the manufacturer. The Sentry Key Immobilizer Module (SKIM) has a unique "Secret Key" code programmed into it by the manufacturer. When a Sentry Key transponder is programmed into the memory of the SKIM, the SKIM learns the transponder identification code from the transponder, and the transponder learns the "Secret Key" code from the SKIM. Each of these codes is stored within the transponder and in the nonvolatile memory of the SKIM. Therefore, blank keys for the SKIS must be programmed by and into the SKIM, in addition to being cut to match the mechanical coding of the ignition lock cylinder. See Sentry Key Immobilizer System Transponder Programming in this group for more information.

The Sentry Key transponder is within the range of the SKIM transceiver antenna ring when it is inserted in the ignition lock cylinder. When the ignition switch is turned to the Start or On positions, the SKIM transceiver issues a Radio Frequency (RF) signal that excites the transponder chip. The transponder chip responds by issuing an RF signal containing its transponder identification code and the "Secret

DESCRIPTION AND OPERATION (Continued)

Key” code. The SKIM transceiver compares the transponder codes with the codes stored in its memory to determine whether a valid key is in the ignition lock cylinder.

The Sentry Key transponder cannot be repaired and, if faulty or damaged, it must be replaced.

SENTRY KEY IMMOBILIZER SYSTEM INDICATOR LAMP

The Sentry Key Immobilizer System (SKIS) indicator lamp gives an indication when the SKIS is faulty or when the vehicle has been immobilized due to the use of an invalid ignition key. The lamp is controlled by the instrument cluster circuitry based upon messages received from the Sentry Key Immobilizer Module (SKIM) on the Chrysler Collision Detection (CCD) data bus.

The SKIM sends messages to the instrument cluster to turn the lamp on for about three seconds when the ignition switch is turned to the On position as a bulb test. After completion of the bulb test, the SKIM sends bus messages to keep the lamp off for a duration of about one second. Then the SKIM sends messages to the instrument cluster circuitry to turn the lamp on or off based upon the results of the SKIS self-tests. If the SKIS indicator lamp comes on and stays on after the bulb test, it indicates that the SKIM has detected a system malfunction and/or that the SKIS has become inoperative.

If the SKIM detects an invalid key when the ignition switch is turned to the On position, it sends messages to the instrument cluster to flash the SKIS indicator lamp. The SKIM can also send messages to the instrument cluster to flash the lamp and to generate a single audible chime tone. These functions serve as an indication to the customer that the SKIS has been placed in its “Customer Learn” programming mode. See Sentry Key Immobilizer System Transponder Programming in this group for more information on the “Customer Learn” programming mode.

The SKIS indicator lamp uses a replaceable incandescent bulb and bulb holder on the instrument cluster electronic circuit board. Refer to Group 8E - Instrument Panel Systems for diagnosis and service of a faulty SKIS indicator lamp. If the SKIS indicator lamp comes on and stays on after the bulb test function, diagnosis of the SKIS should be performed with a DRB scan tool and the proper Diagnostic Procedures manual.

DIAGNOSIS AND TESTING

SENTRY KEY IMMOBILIZER SYSTEM

WARNING: ON VEHICLES EQUIPPED WITH AIRBAGS, REFER TO GROUP 8M - PASSIVE RESTRAINT SYSTEMS BEFORE ATTEMPTING ANY STEERING WHEEL, STEERING COLUMN, OR INSTRUMENT PANEL COMPONENT DIAGNOSIS OR SERVICE. FAILURE TO TAKE THE PROPER PRECAUTIONS COULD RESULT IN ACCIDENTAL AIRBAG DEPLOYMENT AND POSSIBLE PERSONAL INJURY.

NOTE: The following tests may not prove conclusive in the diagnosis of this system. The most reliable, efficient, and accurate means to diagnose the Sentry Key Immobilizer System involves the use of a DRB scan tool. Refer to the proper Diagnostic Procedures manual for the procedures.

The Sentry Key Immobilizer System (SKIS) and the Chrysler Collision Detection (CCD) data bus network should be diagnosed using a DRB scan tool. The DRB will allow confirmation that the CCD data bus is functional, that the Sentry Key Immobilizer Module (SKIM) is placing the proper messages on the CCD data bus, and that the Powertrain Control Module (PCM) and the instrument cluster are receiving the CCD data bus messages. Refer to the proper Diagnostic Procedures manual for the procedures. Refer to 8W-39 - Vehicle Theft Security System in Group 8W - Wiring Diagrams for complete circuit descriptions and diagrams.

(1) Check the fuses in the fuseblock module. If OK, go to Step 2. If not OK, repair the shorted circuit or component as required and replace the faulty fuse.

(2) Disconnect and isolate the battery negative cable. Unplug the wire harness connector at the SKIM. Check for continuity between the ground circuit cavity of the SKIM wire harness connector and a good ground. There should be continuity. If OK, go to Step 3. If not OK, repair the open circuit to ground as required.

(3) Connect the battery negative cable. Check for battery voltage at the fused B(+) circuit cavity of the SKIM wire harness connector. If OK, go to Step 4. If not OK, repair the open circuit to the fuse in the fuseblock module as required.

DIAGNOSIS AND TESTING (Continued)

(4) Turn the ignition switch to the On position. Check for battery voltage at the fused ignition switch output (run/start) circuit cavity of the SKIM wire harness connector. If OK, use a DRB scan tool and the proper Diagnostic Procedures manual to complete the diagnosis of the SKIS. If not OK, repair the open circuit to the fuse in the fuseblock module as required.

SERVICE PROCEDURES

SENTRY KEY IMMOBILIZER SYSTEM
TRANSPONDER PROGRAMMING

Two programmed Sentry Key transponders are included with the Sentry Key Immobilizer System (SKIS) when it is shipped from the factory. The Sentry Key Immobilizer Module (SKIM) can be programmed to recognize up to six additional transponders, for a total of eight Sentry Keys. The following "Customer Learn" programming procedure for the programming of additional transponders requires access to at least two of the valid Sentry Keys. If two valid Sentry Keys are not available, Sentry Key programming will require the use of a DRB scan tool and the proper Diagnostic Procedures manual.

CUSTOMER LEARN

(1) Obtain the additional Sentry Key transponder blank(s) that are to be programmed for the vehicle. Cut the additional Sentry Key transponder blanks to match the ignition lock cylinder mechanical key codes.

(2) Insert one of the two valid Sentry Key transponders into the ignition switch and turn the ignition switch to the On position.

(3) After the ignition switch has been in the On position for about three seconds, but no more than fifteen seconds later, cycle the ignition switch back to the Off position. Replace the first valid Sentry Key in the ignition lock cylinder with the second valid Sentry Key and turn the ignition switch back to the On position.

(4) About ten seconds after the completion of Step 3, the SKIS indicator lamp will start to flash and a single audible chime tone will sound to indicate that the system has entered the "Customer Learn" programming mode.

(5) Within about fifty seconds of entering the "Customer Learn" programming mode, turn the ignition switch to the Off position, replace the valid Sentry Key with a blank Sentry Key transponder, and turn the ignition switch back to the On position.

(6) About ten seconds after the completion of Step 5, a single audible chime tone will sound and the

SKIS indicator lamp will stop flashing and stay on solid for about three seconds to indicate that the blank Sentry Key transponder has been successfully programmed. The SKIS will immediately return to normal system operation following exit from the "Customer Learn" programming mode.

(7) Go back to Step 2 and repeat this process for each additional Sentry Key transponder blank to be programmed.

If any of the above steps is not completed in the proper sequence, or within the allotted time, the SKIS will automatically exit the "Customer Learn" programming mode. The SKIS will also automatically exit the "Customer Learn" programming mode if it sees a non-blank Sentry Key transponder when it should see a blank, if it has already programmed eight valid Sentry Keys, or if the ignition switch is turned to the Off position for more than about fifty seconds.

REMOVAL AND INSTALLATION

SENTRY KEY IMMOBILIZER MODULE

WARNING: ON VEHICLES EQUIPPED WITH AIRBAGS, REFER TO GROUP 8M - PASSIVE RESTRAINT SYSTEMS BEFORE ATTEMPTING ANY STEERING WHEEL, STEERING COLUMN, OR INSTRUMENT PANEL COMPONENT DIAGNOSIS OR SERVICE. FAILURE TO TAKE THE PROPER PRECAUTIONS COULD RESULT IN ACCIDENTAL AIRBAG DEPLOYMENT AND POSSIBLE PERSONAL INJURY.

(1) Disconnect and isolate the battery negative cable.

(2) Remove the knee blocker from the instrument panel. See Knee Blocker in Group 8E - Instrument Panel Systems for the procedures.

(3) Insert the key in the ignition lock cylinder and turn the ignition switch to the On position.

(4) Insert a small screwdriver or pin punch through the access hole in the lower steering column shroud and depress the ignition lock cylinder retaining tumbler (Fig. 2).

(5) While holding the retaining tumbler depressed, pull the ignition lock cylinder and key out of the ignition lock housing.

(6) Remove the three screws that secure the lower steering column shroud to the upper shroud.

(7) If the vehicle is so equipped, move the tilt steering column to the fully lowered position.

(8) If the vehicle is so equipped, loosen the two nuts that secure the non-tilt steering column upper mounting bracket to the dash panel steering column

REMOVAL AND INSTALLATION (Continued)

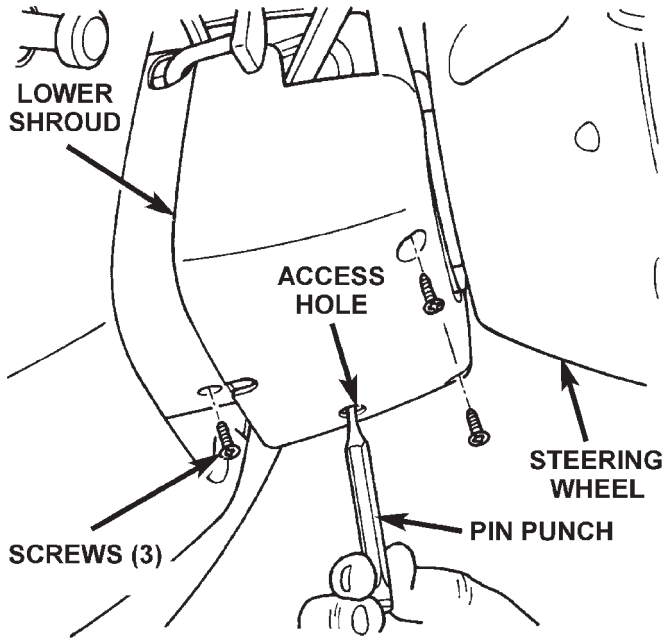

80a483e5

Fig. 2 Steering Column Shrouds Remove/Install
support bracket studs. Lower the column far enough to remove the upper steering column shroud.

(9) Remove both the upper and lower shrouds from the steering column.

(10) Disengage the steering column wire harness retainer from the tab on the top of the Sentry Key Immobilizer Module (SKIM) mounting bracket (Fig. 3).

(11) Unplug the wire harness connector from the SKIM receptacle.

(12) The SKIM mounting bracket features a clip formation that secures the SKIM to the inboard lower flange of the steering column jacket. Pull downward on the connector end of the SKIM mounting bracket to release this clip from the steering column jacket.

(13) Rotate the SKIM and its mounting bracket downwards and then to the side away from the steering column to slide the SKIM antenna ring from around the ignition switch lock cylinder housing.

(14) Remove the SKIM from the vehicle.

(15) Reverse the removal procedures to install. Tighten the non-tilt steering column mounting nuts to 22 N·m (200 in. lbs.) and the steering column shroud mounting screws to 2 N·m (18 in. lbs.).

(16) If the SKIM is replaced with a new unit, a DRB scan tool and the proper Diagnostic Procedures manual MUST be used to initialize the new SKIM and to program at least two Sentry Key transponders.

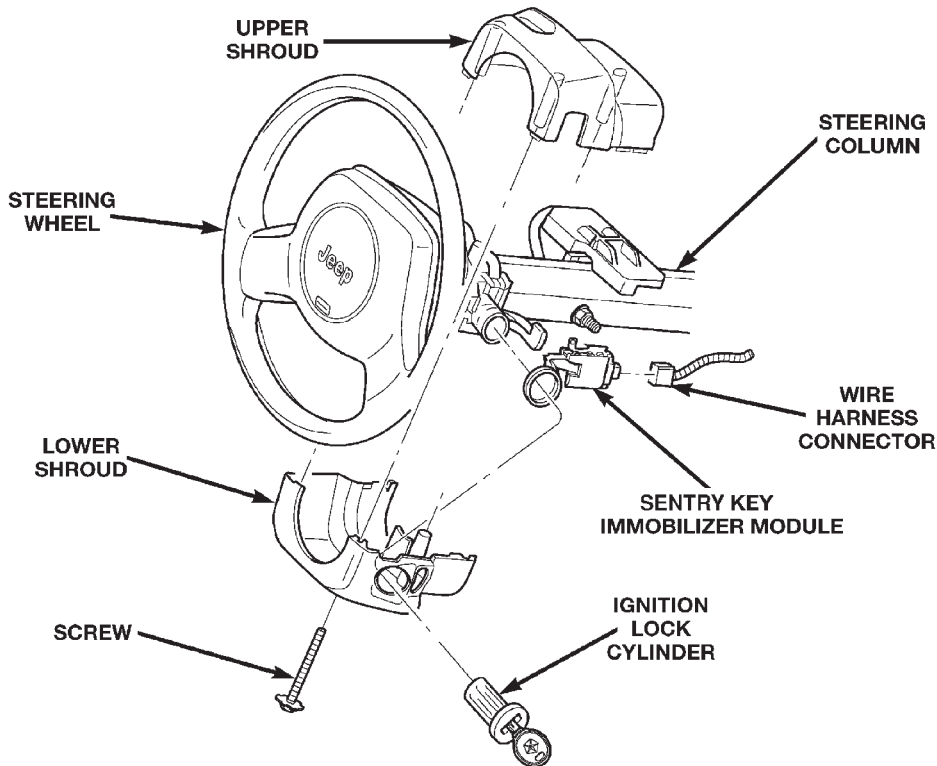

80b46c13

Fig. 3 Sentry Key Immobilizer Module Remove/Install

